

**Proposed Data Centre at No. 7-11 Wing
Kin Road, Kwai Chung (K.C.T.L. 145)**

**Sewerage Impact Assessment
(V1.0)**

Feb 2025

Reviewed By 
(Technical Director: K.S. Lee)

REMARKS:

The information supplied and contained within this report is, to the best of our knowledge, correct at the time of printing.

CINOTECH accepts no responsibility for changes made to this report by third parties.

CINOTECH CONSULTANTS LIMITED

Room 1710, Technology Park

18 On Lai Street

Shatin, NT, Hong Kong

Tel: (852) 2151 2083 Fax: (852) 3107 1388

Email: info@cinotech.com.hk

TABLE OF CONTENTS

1	INTRODUCTION.....	2
1.1	BACKGROUND.....	2
2	THE PROJECT	2
2.1	THE SITE	2
2.2	THE PROPOSED DEVELOPMENT.....	2
3	SEWERAGE IMPACT ASSESSMENT	3
3.1	METHODOLOGY	3
3.2	SEWAGE DISCHARGE FROM THE PROJECT	3
3.3	SEWAGE DISCHARGE FROM THE VICINITY	3
3.4	REVIEW OF SEWAGE SYSTEM.....	5
3.5	PROPOSED NEW SEWER	6
4	CONCLUSION	7

LIST OF TABLES

Table 3-1	Estimation of Population	3
Table 3-2	Calculation of Sewage Discharge.....	3
Table 3-3	Sewage Discharge from Surrounding Catchments.....	4
Table 3-4	Capacity of Existing Public Sewers.....	5
Table 3-5	Utilization of the Existing Sewer.....	5
Table 3-6	Proposed New Sewer.....	6

LIST OF FIGURES

Figure 2-1	Location of the Project Site
Figure 2-2	Zoning in the Vicinity of the Project Site
Figure 3-1	Sewage Catchments and Existing Public Sewers in the Vicinity - Overview
Figure 3-2	Existing Sewers in the Vicinity
Figure 3-3	Proposed New Sewer and Manhole

LIST OF APPENDICES

Appendix 2-1	Development Parameters and Tentative Section Plan
Appendix 3-1	Sewage Discharge from Surrounding Catchments
Appendix 3-2	Detail Calculation of the Sewers
Appendix 3-3	Manhole Internal Condition Survey (MHICS) Report

1 INTRODUCTION

1.1 Background

- 1.1.1 OXO YW Limited (“the Project Proponent”) has proposed to develop a data centre located at No. 7-11 Wing Kin Road, Kwai Chung.
- 1.1.2 Cinotech Consultants Limited was commissioned by OXO YW Limited to carry out a Sewerage Impact Assessment (SIA) to assess and envisage any potential sewerage impact on the implementation of the Project and to recommend SIA mitigation measures.
- 1.1.3 This SIA is prepared to support the planning permission from the Town Planning Board (TPB) under Section 16 of the Town Planning Ordinance (CAP. 131) for a data centre with minor relaxation of plot ratio restriction from 9.5 to 11.4, and height restriction from 105mPD to 109.55mPD.

2 THE PROJECT

2.1 The Site

- 2.1.1 The Application Site (the "Site") is located in an industrial area in Kwai Chung, bordered by Wing Chong Road to the west, Wing Kin Road to the east, Global Trade Centre to the north, and Hou Feng Industrial Building to the south (see **Figure 2-1**). The Site and its surroundings fall within the industrial zone, as per the *Approved Kwai Chung Outline Zoning Plan No. S/KC/32* (see **Figure 2-2**).
- 2.1.2 The Site covers approximately 964 m² (about 929 m² excluding the additional area) and is currently occupied by a 2-storey industrial building. Planning applications have been submitted and approved with conditions in 2020 (Application No.: A/KC/457) and 2023 (Application No.: A/KC/496) for Offensive Trades use (Lard Boiling Factory) and Industrial use (Warehouse), respectively.

2.2 The Proposed Development

- 2.2.1 The Applicant proposes to redevelop the Application Site into a 17-storey data centre with a height of 109.55mPD and plot ratio of 11.4. The tentative layout of the proposed development is shown in **Appendix 2-1**, with a planned completion date of 2029.

3 SEWERAGE IMPACT ASSESSMENT

3.1 Methodology

- 3.1.1 “*Guidelines for Estimating Sewage Flows for Infrastructure Planning*” (GESF), version 1.0, March 2005, prepared by Environmental Protection Department (EPD) provides guidelines for the unit flow factor, catchment inflow factor and peaking factor. The daily sewage discharge and the peak sewage flow are estimated by population, unit flow factors and peaking factors.
- 3.1.2 “*Sewerage Manual – Key Planning Issues and Gravity Collection System*”, third edition, May 2013, (hereafter called “the DSD Manual”) prepared by Drainage Services Department (DSD) provides guidelines for the design of the drainage system. The capacities of the public sewers are calculated by Colebrook-White Equation.

3.2 Sewage Discharge from the Project

- 3.2.1 The proposed development is intended solely for data centre use. While the data centre is generally expected to be unmanned, staff will occasionally need to enter the data halls for maintenance. As a result, sewage will be generated by the staff.
- 3.2.2 From Figure 15 of Commercial and Industrial Floor Space Utilization (CIFUSUS), published by Planning Department, the staff density for I/O buildings is 4.4 persons per 100 m² for Financial, Insurance, Real Estate & Business Services. **Table 3-1** indicates the population calculation of the Project.

Table 3-1 Estimation of Population

Section	GFA	Staff Density per 100 m ² [2]	Population (Staff)
Data Centre	10,992	4.4	484
Total	--	--	484

[1] The development parameters are provided by the project architect.

[2] The following worker density are from Figure 15 of Commercial and Industrial Floor Space Utilization Survey 2005.

-- Financial, Insurance, Real Estate & Business Services (4.4 employee per 100 m²)

- 3.2.3 From EPD’s GESF, the Unit Flow Factors is 0.08 m³/day/person for Financial, Insurance, Real Estate & Business Services. The estimated sewage flow rate from the Project (38.7 m³/day) is summarised in **Table 3-2**.

Table 3-2 Calculation of Sewage Discharge

Occupant Type	Unit Flow Factors [1] (m ³ /day/person)	No. of Occupants / Employee	Flow Rate (m ³ /day)
Data Centre	0.08[2]	484	38.7
Total		-	38.7

[1] EPD's Guidelines for Estimating Sewage Flows for Infrastructure Planning.

[2] The Unit Flow Factor for J6 (Financial, Insurance, Real Estate & Business Services) in Table T-2 of GEFS has been adopted.

3.3 Sewage Discharge from the Vicinity

- 3.3.1 The public sewage network in the vicinity is illustrated in **Figure 3-1**. The surrounding developments near the Project is sectioned into different catchments (A-O) based on the existing sewage system.

- 3.3.2 The GFA of the catchments are based on the land lot size and maximum allowable plot ratio (9.5 for industrial buildings) in general unless the actual plot ratio is far from the maximum value¹. As the warehouse in the vicinity also provide logistics service, the usage with higher sewage discharge per unit area, i.e.: logistics (transportation), has been adopted for conservative assessment. For industrial building of multiple type², manufacturing type has been assumed for conservative assessment.
- 3.3.3 Catchments N & O are columbarium and therefore, the number of visitors on Ching Ming Festival Day have been adopted for the sewage discharge calculation. Kwai Chung Columbarium (Catchment N) has 9,276 niches and 16,000 visitors during Ching Ming Festival in 2019 according to press release³. The columbarium at Wing Lap Street 2-6 (Catchment O) is allowed to provided 23,000 niches according to its approved planning application (Application No. A/KC/437⁴). As no visitor statistic for the ultimate scenario, when the 23,000 niches are fully occupied, is available, the number of visitors per niches ratio of Kwai Chung Columbarium has been adopted, resulting in 39,672 visitors on Ching Ming Festival Day. In addition, since the number of visitors outweigh the number of staff for the columbarium, the discharge from the staff has been ignored.
- 3.3.4 The sewage catchment areas in the vicinity are illustrated in **Figure 3-1** and summarised in **Table 3-3**. The detailed calculations are presented in **Appendix 3-1**.

Table 3-3 Sewage Discharge from Surrounding Catchments

Catchment ID	Development	Total Flowrate / catchment (m ³ /day)
A	Wing Kin Road 22, Gold Way Industrial Centre, Refuse Collection Point	1,137.5
B	Global Trade Centre, Wing Kin Road 19-21	244.7
C	Wing Kin Road 8-12	31.4
D	Wing Kin Industrial Building	246.6
E	Kwai Wan Industrial Building	166.4
F	Hou Feng Industrial Building	317.9
G	Hopewell Logistics Centre, Aji Ichiban Centre	372.1
H	Wing Loi Industrial Building, Valid Industrial Building, Mei Kei Industrial Building, Wing Lap Street 24-28	719.7
I	Good Ba Ba Hitech Building	51.7
J	Wing Hau Street Driving Test Centre	1.1
K	Kerry TC Warehouses 2	401.6
L	Wing Shing Industrial Building	325.4
M	38 Wing Kei Road	62.6
N	Kwai Chung Columbarium	640.0
O	Wing Lap Street 2-6 (columbarium)	1,586.9

[i] The calculation is detailed in **Appendix 3-1**.

¹ For example, Wing Kin Road 8-12 in Catchment C consists of low-rise buildings only.

² For example, Wing Kin Road 22 consists of 5 floors for storage, and 13 floors for manufacturing according to layout plan

³ Number of visitor (Kwai Chung Columbarium) - <https://www.cso.gov.hk/eng/blog/blog20200315.htm>

Number of niches (Kwai Chung Columbarium) - <https://www.info.gov.hk/gia/general/202106/16/P2021061600496.htm>

⁴ Planning Application No. A/KC/437 - https://www2.ozp.tpb.gov.hk/gist/apply/en_tc/A_KC_437_TC.pdf

3.4 Review of Sewerage System

- 3.4.1 As the scale of the Proposed Project is larger than the existing 2-storey industrial building, the addition sewage discharge may induce potential sewerage impact to the existing public sewerage system, thus the utilization of the downstream sewers shall be checked.
- 3.4.2 The sewage from the Site will be discharged to Public Sewer Manhole FMH4022807, flow along 400mm sewers (PS01 – PS04, **Figure 3-2**) along Wing Kin Road, then join with the 750mm sewers (PS05 – PS06, **Figure 3-2**) along Kwai Hei Street.
- 3.4.3 As the invert level and material of the 400mm sewer along Wing Kin Road are the key parameter to determine the potential sewerage impact from the Site, Castco Testing Centre Ltd. has been hired to conduct the manhole survey. The manhole survey report is provided in **Appendix 3-3**.
- 3.4.4 The capacities of the downstream sewer sections (PS01 – PS06, **Figure 3-2**) are calculated by Colebrook-White Equation and listed in **Table 3-4**. The detailed calculation is shown in **Table A of Appendix 3-2**. The adopted information of the sewers PS01 - PS06 are based on the manhole survey report (**Appendix 3-3**) and Geoinfo Map⁵.

Table 3-4 Capacity of Existing Public Sewers

Pipe Section	Upstream Manhole	Downstream Manhole	Full Capacity (L/s)
PS01	FMH4022807	FMH4022808	299.9
PS02	FMH4022808	FMH4022809	468.5
PS03	FMH4022809	FMH4022810	444.6
PS04	FMH4022810	FMH4022768	239.0
PS05	FMH4022768	FMH4022769	788.8
PS06	FMH4022769	FMH4022770	695.3

- 3.4.5 **Table 3-5** shows a summary of the proportion of peak flow to full capacity from surrounding catchments areas to each segment of existing pipe sections. The detailed calculation is shown in **Table B of Appendix 3-2**.

Table 3-5 Utilization of the Existing Sewer

Pipe Section	Full Capacity (L/s)	Peak Flow (L/s) ^[1-5]	Utilization (%)
PS01	299.9	92.4	31%
PS02	468.5	128.4	27%
PS03	444.6	139.0	31%
PS04	239.0	139.0	58%
PS05	788.8	323.1	41%
PS06	695.3	323.1	46%

[1] The contribution population = total catchment discharge (m³/day) / 0.27(m³/day/person)

[2] Peaking Factor of 8 for contribution population <1,000, 6 for contribution population of 1000 – 5000, 5 for contribution population of 5000-10000 and 4 for contribution population of 10000 – 50000 are adopted.

[3] The site is located within Kwai Chung District. The Catchment Inflow Factors of Kwai Chung (=1.1) has been adopted.

[4] Peak Flow = [Daily average dry weather flow × Peaking Factor (including stormwater allowance) / 24 / 3600] × Catchment Inflow Factor.

- 3.4.6 According to the calculation, the existing downstream sewers can cater for the expected sewage flow. No upgrading work is necessary.

⁵ Geoinfo map - <https://www.map.gov.hk/gm/>

3.5 Proposed New Sewer

- 3.5.1 The sewage discharge from Project is proposed to be collected by a terminal manhole (FTMH01) and discharged via a proposed pipe (PP01) to an existing public sewage manhole (FMH4022807). The 225mm PE sewer (PP01) is proposed with slope of 1:100. The information of the proposed new pipe is listed in **Table 3-6**; and detailed in **Appendix 3-2**.
- 3.5.2 The alignment of the proposed new sewer is illustrated in **Figure 3-3**. The precise alignment and invert levels will subject to detailed design. The Project Proponent will be responsible for constructing the proposed pipe PP01 and its associate works.

Table 3-6 Proposed New Sewer

Segment	Proposed New ^[1]			Full Capacity (L/s)	Total Peak Flow (L/s)	Total Discharge Loading to Pipe Capacity (%)
	Upstream Invert Level (mPD)	Downstream Invert Level (mPD)	Diameter (mm)			
Proposed New Sewer						
PP01	FTMH01	FMH4022807	225	56.4	3.9	7%

[1] The precise alignment and invert levels of the proposed pipes will be subject to detail design.

4 CONCLUSION



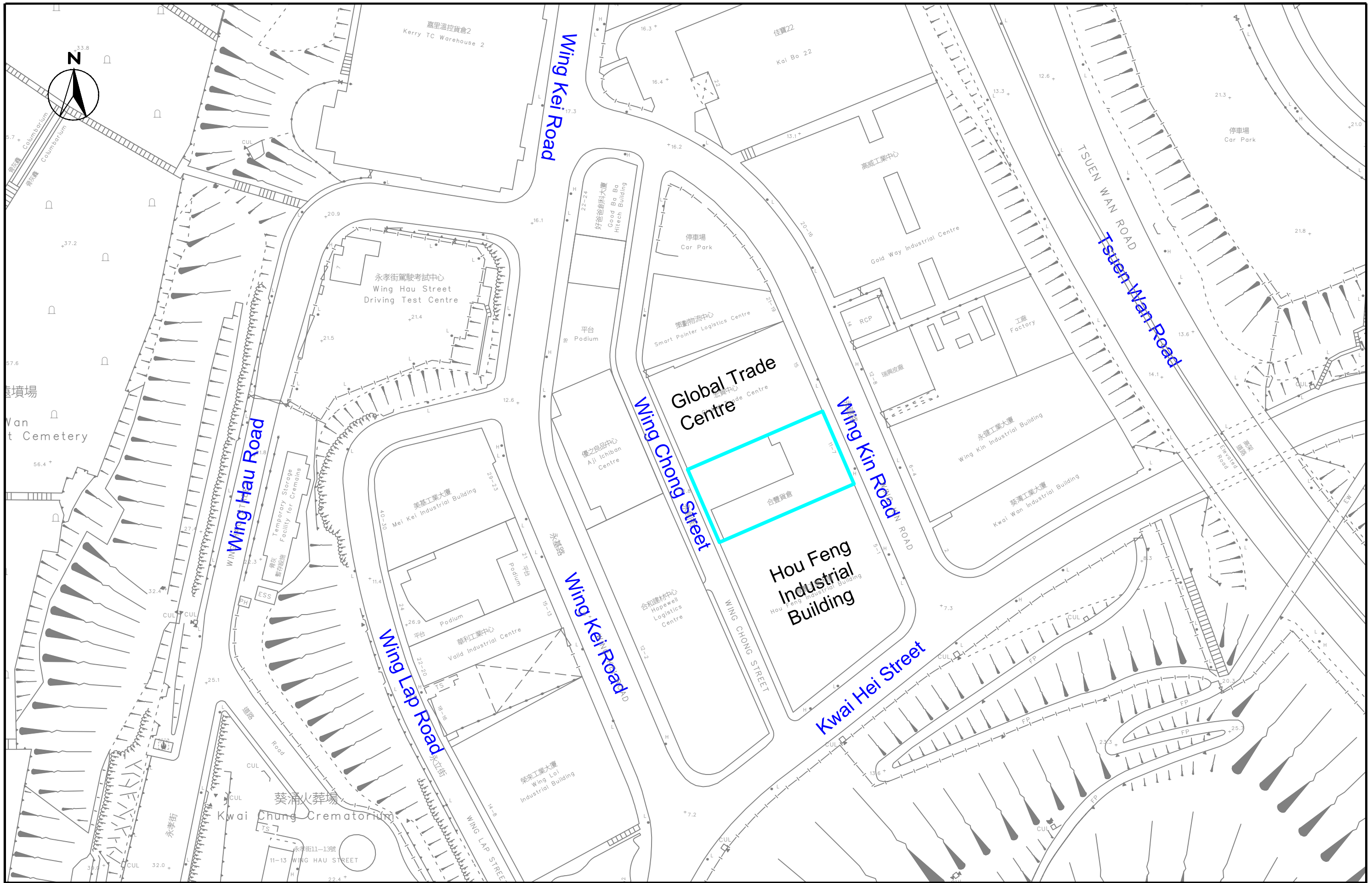

- 4.1.1 This sewage impact assessment (SIA) has been prepared to address all the potential adverse sewerage impacts arose from the proposed development of the lot, and to recommend mitigation measures and improvement works, if required.
- 4.1.2 The estimated daily sewage discharge from the Project is 38.7 m³/day. Sewage from the Project will be collected by the new terminal sewage manhole FTMH01 and discharged to existing sewer manhole FMH4022807 via a proposed 225mm PE sewer (PP01) with slope of 1:100. Actual layout and invert levels of the proposed sewer are subject to detailed design.
- 4.1.3 The sewage network is considered to have sufficient capacities to cater for the expected sewage flows from the Project and the surrounding catchments. Therefore, no adverse sewerage impact on the public sewage system is expected from the Project.

FIGURES

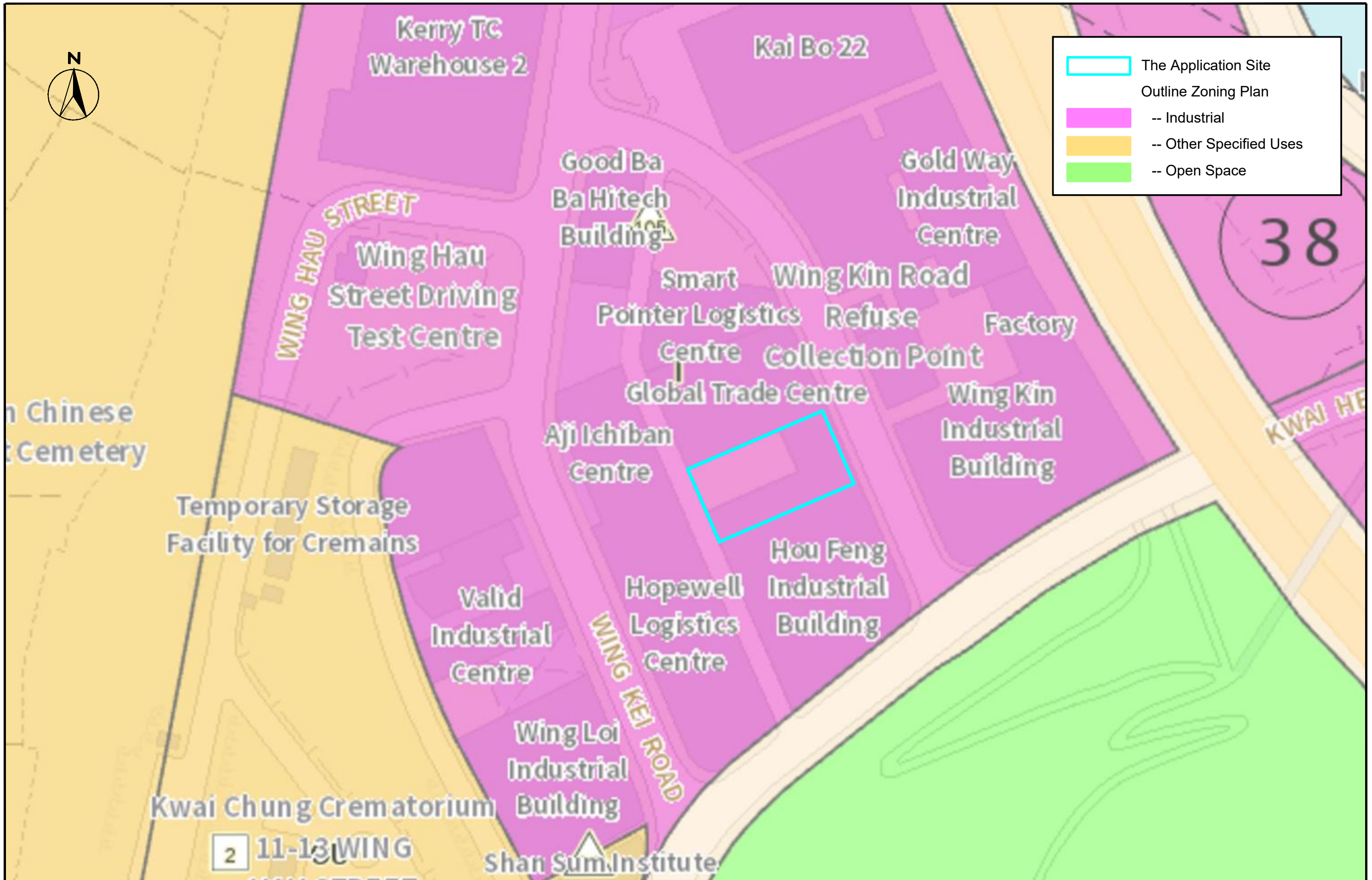



SCALE	1:1000 @ A3	DATE	Jan 2025
CHECK	CC	DRAWN	LL
JOB No.	IA23170	DRAWING No.	2-1
		REV	-

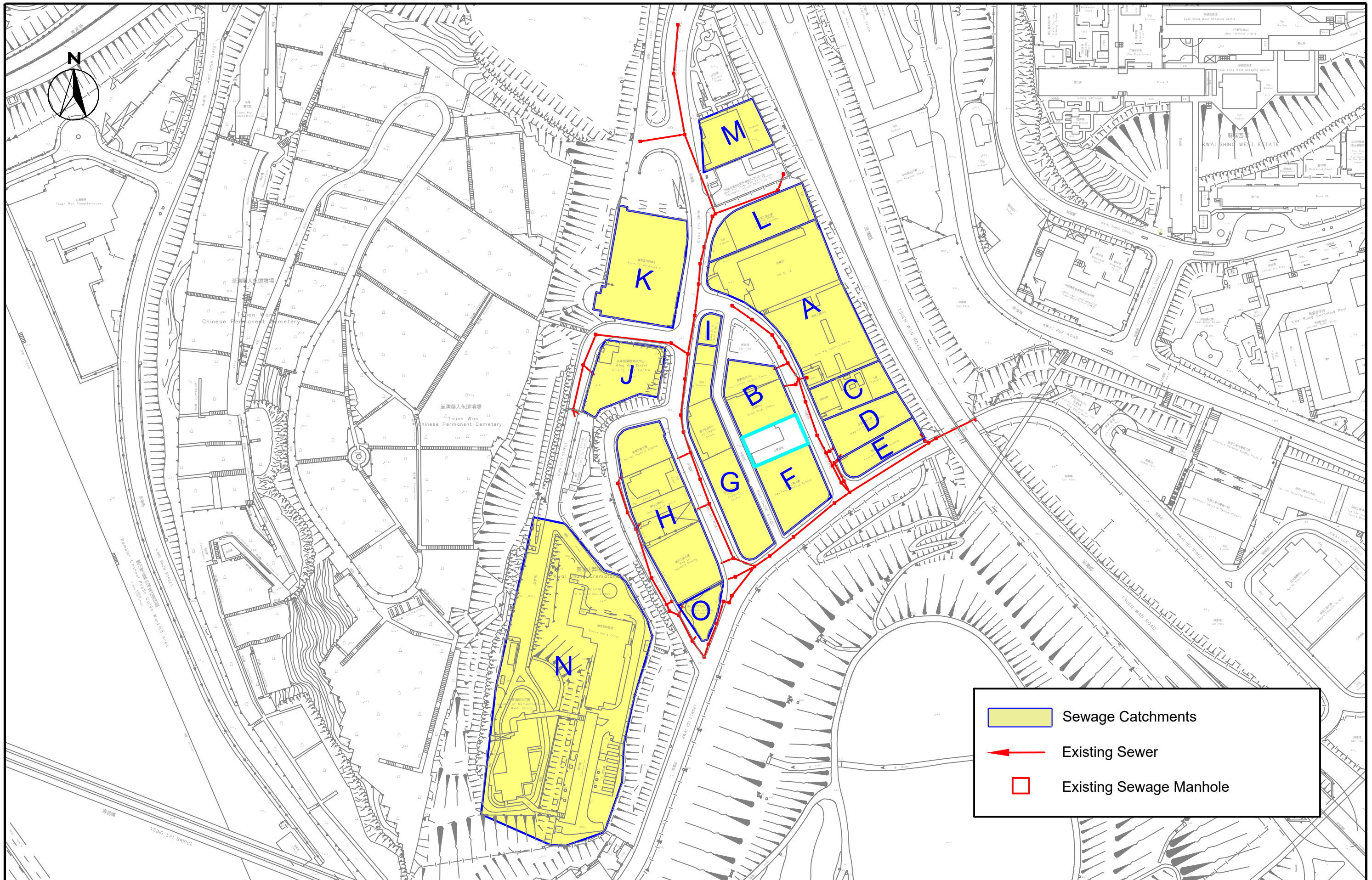

	The Application Site
	-- Industrial
	-- Other Specified Uses
	-- Open Space

SCALE	1:1000 @ A3	DATE	Jan 2025
CHECK	CC	DRAWN	LL
JOB No.	IA23170	DRAWING No.	2-2
		REV	-

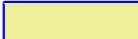

	Sewage Catchments
	Existing Sewer
	Existing Sewage Manhole

SCALE	1:2500 @ A3	DATE	Jan 2025
CHECK	CC	DRAWN	LL
JOB No.	IA23170	DRAWING No.	3-1
		REV	-

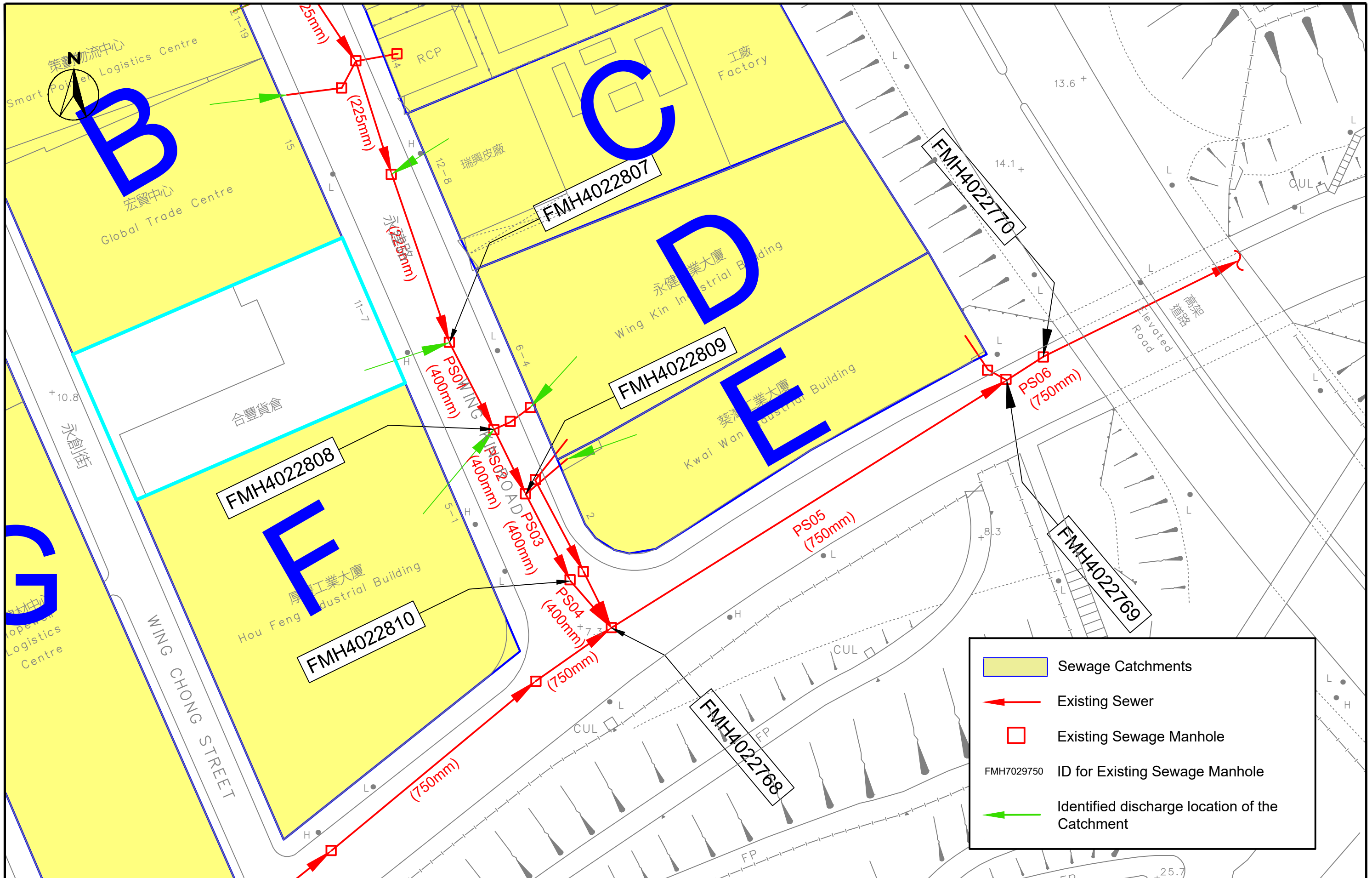

	Sewage Catchments
	Existing Sewer
	Existing Sewage Manhole
FMH7029750	ID for Existing Sewage Manhole
	Identified discharge location of the Catchment



Proposed Data Centre at No. 7-11 Wing Kin Road, Kwai Chung (K.C.T.L. 145)

Existing Sewers in the Vicinity

SCALE	1:500 @ A3	DATE	Jan 2025
CHECK	CC	DRAWN	LL
JOB No.	IA23170	DRAWING No.	3-2
		REV	-

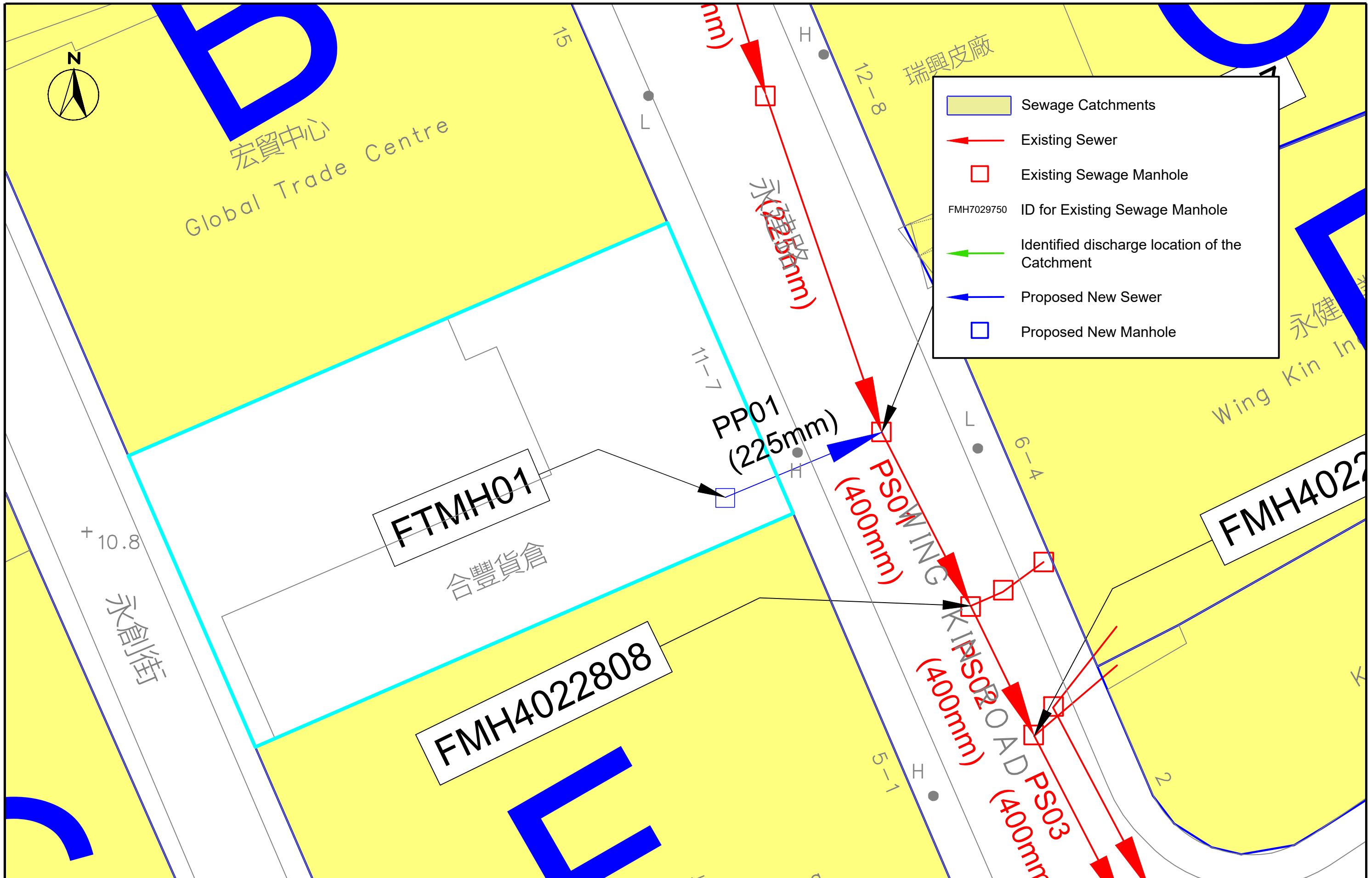

	Sewage Catchments
	Existing Sewer
	Existing Sewage Manhole
FMH7029750	ID for Existing Sewage Manhole
	Identified discharge location of the Catchment
	Proposed New Sewer
	Proposed New Manhole

**APPENDIX 2-1
DEVELOPMENT PARAMETERS AND
TENTATIVE SECTION PLANTENTATIVE
SECTION PLAN**

1.0	<u>PLOT RATIO & SITE COVERAGE CALCULATIONS</u>						
1.1	SITE AREA (UNDER LEASE)	929.031	m ²				
1.2	ADDITIONAL SITE AREA FACING WING CHONG STREET	35.169	m ²				
1.3	SITE AREA FOR PR & SC CALCULATIONS	964.200	m²				
1.4	PERMITTED PLOT RATIO UNDER OZP	9.5					
1.5	ADDITIONAL PLOT RATIO UNDER PLANNING APPLICATION (20%)	1.9					
1.6	PROPOSED PLOT RATIO	11.4					
1.7	PROPOSED TOTAL GROSS FLOOR AREA	10,991.880	m²				
1.8	CLASS OF SITE	A					
1.9	PERMITTED SITE COVERAGE UNDER 40m (82%) UNDER PNAP-132	790.644	m ²				
1.10	PERMITTED SITE COVERAGE ABOVE 61m (65%) UNDER PNAP-132	626.730	m ²				
2.0	<u>PROPOSED DEVELOPMENT CALCULATIONS</u>	Accountable GFA		Mandatory Unaccountable GFA	CFA / Floor	Site Coverage	
2.1	BASEMENT 2 FLOOR		m ²	268.50	m ²	268.5	m ² -
2.2	BASEMENT 1 FLOOR	51.03	m ²	778.97	m ²	830.0	m ² -
2.3	GROUND FLOOR	658.20	m ²	436.40	m ²	782.0	m ² 81.104%
2.4	1st FLOOR (E&M FLOOR)	698.80	m ²	40.20	m ²	739.0	m ² 76.644%
2.5	2nd FLOOR (E&M FLOOR)	699.10	m ²	39.90	m ²	739.0	m ² 76.644%
2.6	3rd FLOOR (E&M FLOOR)	726.00	m ²	13.00	m ²	739.0	m ² 76.644%
2.7	4th FLOOR (DATA HALL)	726.00	m ²	13.00	m ²	739.0	m ² 76.644%
2.8	5th FLOOR (DATA HALL)	726.00	m ²	13.00	m ²	739.0	m ² 76.644%
2.9	6th FLOOR (E&M FLOOR)	606.00	m ²	13.00	m ²	619.0	m ² 64.198%
2.10	7th FLOOR (DATA HALL))	606.00	m ²	13.00	m ²	619.0	m ² 64.198%
2.11	8th FLOOR (DATA HALL)	606.00	m ²	13.00	m ²	619.0	m ² 64.198%
2.12	9th FLOOR (DATA HALL)	606.00	m ²	13.00	m ²	619.0	m ² 64.198%
2.13	10th FLOOR (E&M FLOOR)	506.00	m ²	113.00	m ²	619.0	m ² 64.198%
2.14	11th FLOOR (DATA HALL)	606.00	m ²	13.00	m ²	619.0	m ² 64.198%
2.15	12th FLOOR (DATA HALL)	606.00	m ²	13.00	m ²	619.0	m ² 64.198%
2.16	13th FLOOR (DATA HALL)	606.00	m ²	13.00	m ²	619.0	m ² 64.198%
2.17	14th FLOOR (E&M FLOOR)	606.00	m ²	13.00	m ²	619.0	m ² 64.198%
2.18	15th FLOOR (DATA HALL)	606.00	m ²	13.00	m ²	619.0	m ² 64.198%
2.19	16th FLOOR (DATA HALL)	606.00	m ²	13.00	m ²	619.0	m ² 64.198%
2.20	MAIN ROOF	140.75	m ²	94.25	m ²	235.0	m ² -
2.21	UPPER ROOF	-	m ²	65.00	m ²	65.0	m ² -
2.22	PROPOSED TOTAL GROSS FLOOR AREA	10,991.88	m²	2005.22	m²	12,684.50	
2.25	HEIGHT OF GROUND FLOOR	11.00	m				
2.26	HEIGHT OF 1st FLOOR	6.00	m				
2.27	HEIGHT OF 2nd FLOOR	6.00	m				
2.28	HEIGHT OF 3rd FLOOR	6.00	m				
2.29	HEIGHT OF 4th - 18th FLOOR (@5.5m PER FLOOR)	71.50	m				
2.30	PROPOSED TOTAL HEIGHT	100.50	m				
2.31	MEAN SITE STREET LEVEL	8.390	mPD				
2.32	HEIGHT OF GROUND FLOOR ABOVE MEAN STREET LEVEL	0.660	m				
2.33	PROPOSED HEIGHT ABOVE PRINCIPAL DATUM	109.550	mPD				
2.34	PERMITTED HEIGHT UNDER OZP	105.000	mPD				
2.35	ADDITIONAL HEIGHT UNDER PLANNING APPLICATION	4.550	mPD	4.15%			
3.1	Required Set Back Area at G/F under PNAP APP-132 (8% of Site Area)	77.136	m ²				
3.2	Planter Area at G/F	2.00	m ²				
3.3	Planter Area at 1/F	11.00	m ²				
3.4	Planter Area at 2/F	4.00	m ²				
3.5	Planter Area at 3/F	9.00	m ²				
3.6	Vertical Green Area	169.00	m ²				
3.7	Total Greening Area	195.00	m²				
3.8	Greenery Site Coverage - Primary Zone	17.73%					
3.9	Greenery Site Coverage - Overall	20.22%					

NOTES:
DO NOT SCALE DRAWINGS.
ALL DIMENSIONS MUST BE VERIFIED AT THE WORK BY THE CONTRACTOR.
ALL PRINTS, SPECIFICATIONS AND THEIR COPYRIGHT ARE THE PROPERTY OF THE ARCHITECTS AND SHALL BE RETURNED AT THE COMPLETION OF THE WORK.

REVISION		
NO	DATE	DESCRIPTION

ARCHITECT
STUDIO | R&A
18/F | Xiu Hua Commercial Building
211-213 Jaffe Road | Wan Chai | HK
Tel: 3583-2000 | Fax: 8143-1130
Email: mail@studiorca.com
**STUDIO | RAYMOND CHAU |
ARCHITECTURE | LIMITED**

PROJECT NAME
**PROPOSED DATA CENTRE
7-11 WING KIN ROAD
KWAI CHUNG, N.T.**

DRAWING TITLE
**DEVELOPMENT
SCHEDULE**

DRAWN BY	TK	CHECKED BY	RC
SCALE	NIL	DATE	2025.02.14
JOB No.	2208	DRAWING No.	A-00

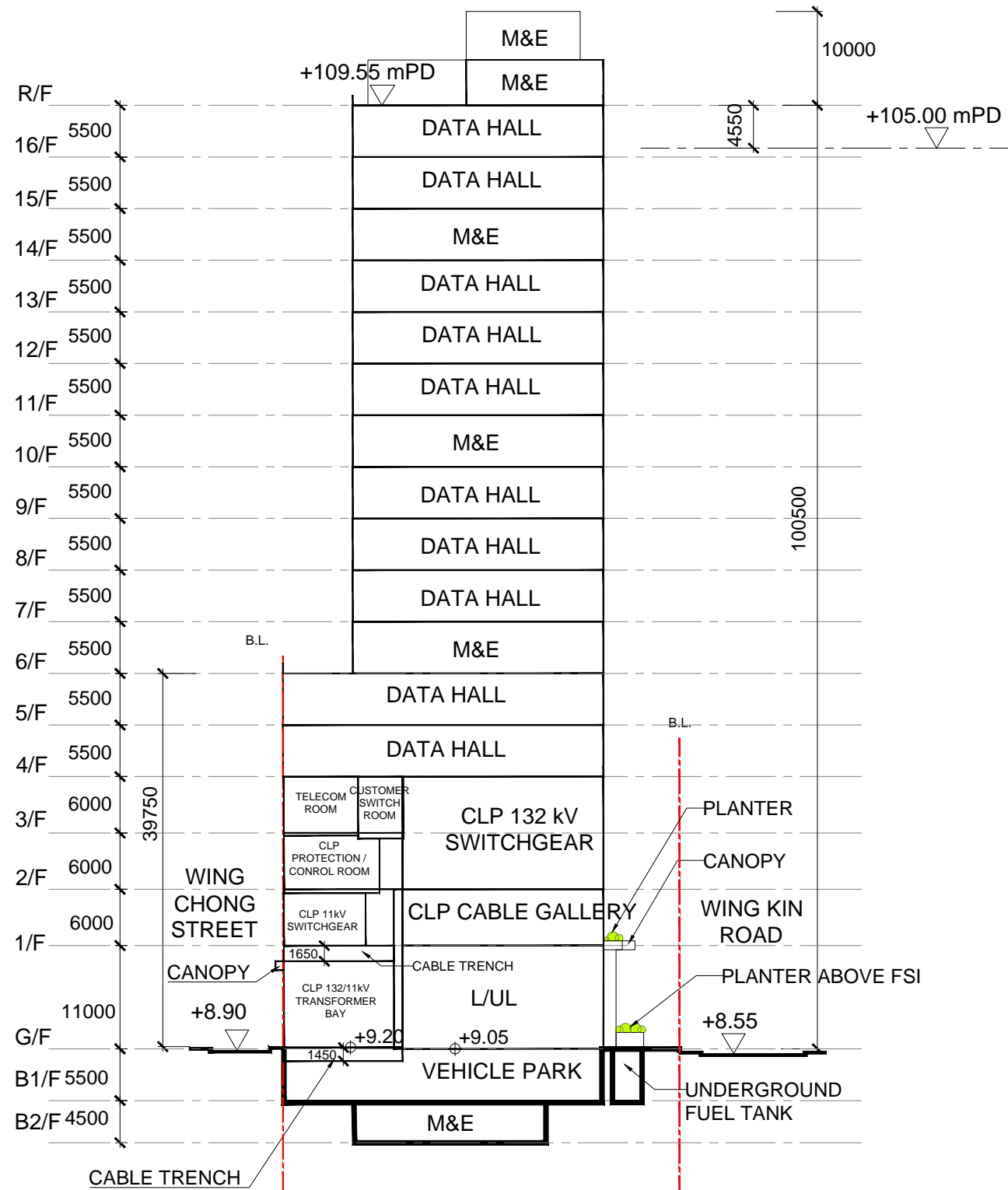

NOTES:
DO NOT SCALE DRAWINGS.
ALL DIMENSIONS MUST BE VERIFIED AT THE WORK BY THE CONTRACTOR.
ALL PRINTS, SPECIFICATIONS AND THEIR COPYRIGHT ARE THE PROPERTY OF THE ARCHITECTS AND SHALL BE RETURNED AT THE COMPLETION OF THE WORK.

REVISION		
NO	DATE	DESCRIPTION

ARCHITECT
STUDIO | R&A
18/F | Xiu Hua Commercial Building
211-213 Jaffe Road | Wan Chai | HK
Tel: 3583-2000 | Fax: 8143-1130
Email: mail@studiorca.com

STUDIO | RAYMOND CHAU | ARCHITECTURE | LIMITED

PROJECT NAME
PROPOSED DATA CENTRE
7-11 WING KIN ROAD
KWAI CHUNG, N.T.

DRAWING TITLE
SECTION A-A

DRAWN BY	TK	CHECKED BY	RC
SCALE	1:750	DATE	2025.02.14
JOB No.	2208	DRAWING No.	A-14

**APPENDIX 3-1
SEWAGE DISCHARGE FROM
SURROUNDING CATCHMENTS**

Appendix 3-1: Sewage Discharge from Surrounding Catchments

Catchment ID	Building	Total Office Area (m ²)	Total I/O Building Area (m ²)	Total Transport Area (m ²)	Total Storage Area (m ²)	Total Manufacturing Area (m ²)	Other employees ^[2]	Total Visitors ^[3]	Population / No. of Occupants (by worker density) ^[4]					Flowrate (m ³ /day) ^[5]					Total Flowrate / catchment (m ³ /day)
									Community, Social & Personal Services (staff)	Finance, Insurance, Real Estate & Business Services (Staff)	Transport (staff)	Storage (staff)	Manufacturing (staff)	Community, Social & Personal Services UFF = 0.28	Finance, Insurance, Real Estate & Business Services UFF = 0.08	Transport & Storage UFF=0.18	Manufacturing UFF=0.73	Visitor ^[6] UFF=0.04	
A	Wing Kin Road 22, Gold Way Industrial Centre, Refuse Collection Point	0	0	0	0	67650	6	0	6	0	0	0	1556	1.7	0.0	0.0	1135.8	0.0	1137.5
B	Global Trade Centre, Wing Kin Road 19-21	0	0	6527	0	11913	0	0	0	0	248	0	274	0.0	0.0	44.6	200.0	0.0	244.7
C	Wing Kin Road 8-12	0	0	0	0	1873	0	0	0	0	0	0	43	0.0	0.0	0.0	31.4	0.0	31.4
D	Wing Kin Industrial Building	0	0	0	0	14687	0	0	0	0	0	0	338	0.0	0.0	0.0	246.6	0.0	246.6
E	Kwai Wan Industrial Building	0	0	0	0	9909	0	0	0	0	0	0	228	0.0	0.0	0.0	166.4	0.0	166.4
F	Hou Feng Industrial Building	0	0	0	0	18934	0	0	0	0	0	0	435	0.0	0.0	0.0	317.9	0.0	317.9
G	Hopewell Logistics Centre, Aji Ichiban Centre	0	0	18440	0	14649	0	0	0	0	701	0	337	0.0	0.0	126.1	246.0	0.0	372.1
H	Wing Loi Industrial Building, Valid Industrial Building, Mei Kei Industrial Building, Wing Lap Street 24-28	0	0	0	0	42864	0	0	0	0	0	0	986	0.0	0.0	0.0	719.7	0.0	719.7
I	Good Ba Ba Hitech Building	0	0	0	0	3078	0	0	0	0	0	0	71	0.0	0.0	0.0	51.7	0.0	51.7
J	Wing Hau Street Driving Test Centre	121	0	0	0	0	0	0	4	0	0	0	0	1.1	0.0	0.0	0.0	0.0	1.1
K	Kerry TC Warehouses 2	0	0	58720	0	0	0	0	0	0	2231	0	0	0.0	0.0	401.6	0.0	0.0	401.6
L	Wing Shing Industrial Building	0	0	0	0	19380	0	0	0	0	0	0	446	0.0	0.0	0.0	325.4	0.0	325.4
M	38 Wing Kei Road	0	17772	0	0	0	0	0	0	0	0	0	0	0.0	62.6	0.0	0.0	0.0	62.6
N	Kwai Chung Columbarium	0	0	0	0	0	0	16000	0	0	0	0	0	0.0	0.0	0.0	0.0	640.0	640.0
O	Wing Lap Street 2-6 (columbarium)	0	0	0	0	0	0	39672	0	0	0	0	0	0.0	0.0	0.0	0.0	1586.9	1586.9

Notes:

- [1] Total Area = land lot size x maximum allowable plot ratio (9.5)
- [2] Other employees include the staffs of Refuse Collection Point (classified as community services).
- [3] The total visitors is the number of grave sweepers on Ching Ming Festival Day.
- [4] The worker density for Community, Social & Personal Services Area (5.9 employee per 100 m²), Transport Area (3.8 employee per 100 m²), Storage Area (0.4 employee per 100 m²), Manufacturing Area (2.3 employee per 100 m²) and I/O Building (4.4 employee per 100 m²)employee are from Figure 9 & 15 of Commercial and Industrial Floor Space Utilization Survey 2005.
- [5] The Unit Flow Factors are 0.28, 0.18, 0.73, 0.04 m³/person/day for "Community, Social & Personal Service", "Transport & storage", "Manufacturing", "Visitor" respectively.
- [6] The Unit Flow Factor of student has been adopted as the visitors.

**APPENDIX 3-2
DETAILED CALCULATION OF THE
SEWERS**

Appendix 3-2: Detailed Calculation of the Sewers

Table A: Calculation of Sewer Capacity

Segment	Upstream Manhole	Downstream Manhole	Upstream Invert Level (mPD)	Downstream Invert Level (mPD)	Length (m)	Diameter (mm)	Area (m ²)	Hydraulic Radius (m)	Slope	Kinematic Viscosity (m ² /s)	Pipe material	Hydraulic Pipeline Roughness (m) ^[1]	Velocity (m/s)	Full Capacity (l/s)
Existing Downstream Sewers														
PS01	FMH4022807	FMH4022808	<u>6.400</u>	<u>6.176</u>	14.0	<u>400</u>	0.126	0.1	0.0160	0.00000114	<u>Slimed Clayware</u>	0.0006	2.39	299.9
PS02	FMH4022808	FMH4022809	<u>6.086</u>	<u>5.682</u>	10.4	<u>400</u>	0.126	0.1	0.0388	0.00000114	<u>Slimed Clayware</u>	0.0006	3.73	468.5
PS03	FMH4022809	FMH4022810	<u>5.597</u>	<u>5.106</u>	14.0	<u>400</u>	0.126	0.1	0.0350	0.00000114	<u>Slimed Clayware</u>	0.0006	3.54	444.6
PS04	FMH4022810	FMH4022768	<u>5.105</u>	<u>5.014</u>	8.9	<u>400</u>	0.126	0.1	0.0102	0.00000114	<u>Slimed Clayware</u>	0.0006	1.90	239.0
PS05	FMH4022768	FMH4022769	<u>4.584</u>	3.860	67.1	<u>675</u>	0.358	0.16875	0.0108	0.00000114	<u>Slimed Concrete</u>	0.003	2.20	788.8
PS06	FMH4022769	FMH4022770	3.860	3.830	6.2	750	0.442	0.1875	0.0048	0.00000114	Slimed Concrete	0.003	1.57	695.3
Proposed New Sewer														
PP01	FTMH01	FMH4022807	--	--	12.2	225	0.040	0.05625	0.0100	0.00000114	PE	0.0003	1.42	56.4

Note:

[1]

The roughness coefficient for slimed clayware sewer under poor condition has been adopted; the ks values are 0.6mm for velocities greater than 1.2m/s, otherwise 3mm.

The roughness coefficient for slimed concrete sewer under poor condition has been adopted; the ks values are 3mm for velocities greater than 1.2m/s, otherwise 6mm.

The roughness coefficient for slimed uPVC sewer under poor condition has been adopted for the proposed PE sewer; the ks values are 0.3mm for velocities greater than 1.2m/s, otherwise 1.5mm.

[2]

The **bolded underlined information** are based on the Manhole Survey.

[3]

The alignment and invert levels of the proposed new sewers are subject to detailed design.

Appendix 3-2: Detailed Calculation of the Sewers

Table B: Utilization of the Sewers

Segment	Upstream Manhole	Downstream Manhole	Full Capacity (L/s)	Catchment	Total catchment discharge (m ³ /day)	Catchment Inflow Factors, P _{CIF} ^[3]	Total catchment discharge with P _{CIF} (m ³ /day)	Contribution Population ^[1]	Peaking Factor ^[2]	Peak Flow ^[4] (L/s)	% of full capacity
Existing Downstream Sewers											
PS01	FMH4022807	FMH4022808	299.9	The Site + Catchment A - C	1452.3	1.1	1597.5	5379	5	92.4	31%
PS02	FMH4022808	FMH4022809	468.5	The Site + Catchment A - D & F	2016.8	1.1	2218.5	7470	5	128.4	27%
PS03	FMH4022809	FMH4022810	444.6	The Site + Catchment A - F	2183.2	1.1	2401.5	8086	5	139.0	31%
PS04	FMH4022810	FMH4022768	239.0	The Site + Catchment A - F	2183.2	1.1	2401.5	8086	5	139.0	58%
PS05	FMH4022768	FMH4022769	788.8	The Site + Catchment A - O	6344.2	1.1	6978.6	23497	4	323.1	41%
PS06	FMH4022769	FMH4022770	695.3	The Site + Catchment A - O	6344.2	1.1	6978.6	23497	4	323.1	46%
Proposed New Sewer											
PP01	FTMH01	FMH4022807	56.4	The Site	38.7	1.1	42.6	143	8	3.9	7%

Note:

[1] The contribution population = total catchment discharge (m³/day) / 0.27(m³/day/person)

[2] Peaking Factor of 8 for contribution population <1,000 , 6 for contribution population of 1000 - 5000, 5 for contribution population of 5000-10000, 4 for contribution population of 10000-50000 are adopted.

[3] The site is located within Kwai Chung District. The Catchment Inflow Factors of Kwai Chung (=1.1) has been adopted.

[4] Peak Flow = Daily average dry weather flow × Peaking Factor (including stormwater allowance) × Catchment Inflow Factor / 24 / 3600, the operation hour is assumed to be 24 hours.

**APPENDIX 3-3
MANHOLE INTERNAL CONDITION
SURVEY (MHICS) REPORT**

CASTCO

佳力高試驗中心有限公司
CASTCO TESTING CENTRE LTD.

Manhole Internal Condition Survey (MHICS) REPORT

Manhole Internal Condition Survey at Wing Kin Road

Project No.: Y22-US-P-103-002
Report No.: Y22-US-P-103-002-R0_00
CASTCO LRN: US0220618-1
Version: 00
June 2022

Prepared by:

Castco Testing Centre Ltd.

Issue Date:

20th June, 2022

FOREWORD

This report presents the results of Manhole Internal Condition Survey (MHICS) at Wing Kin Road.

The report is prepared by our specialist in Underground Utility Industry. According to the findings of the survey on site, it has been checked by well-experienced professional to ensure all data and records are in order and accurate.

Prepared by:

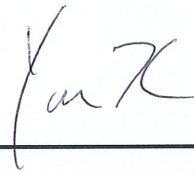

Ki HO**BEng****Project Coordinator**

Checked by:

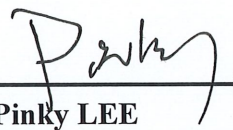

Pinky LEE**BSc in Surveying, OMHKIUS****Project Manager**

Endorsed by:



Stanley CHAN**MScSurv****Senior Manager**

TABLE OF CONTENT

1. INTRODUCTION	1
1.1 Client Information.....	1
1.2 Background.....	1
1.3 Scope of Survey	1
2. SURVEY DETAILS AND SITE DESCRIPTION.....	3
3. SUMMARY OF SURVEY RESULTS	4
4. REFERENCES	5
5. JOB REFERENCES	6
APPENDIX A – SURVEY RESULT DRAWING	7
APPENDIX B – MANHOLE RECORD FORMS	8
APPENDIX C – SURVEY METHODOLOGY	9
APPENDIX D – QUICK REFERENCE FOR MANHOLE CODES	10
APPENDIX E – ELECTRONIC COPY OF SURVEY RESULT.....	12

1. INTRODUCTION

Client information, background and Scope of Survey will be briefed in this Section 1.

1.1 Client Information

Client information is shown in below *Table 1.1.1*.

Table 1.1.1 – Client information

Project Client:	<i>KJL Limited</i>
Project Client's Representative:	Kenneth Li
E-mail:	kjl@kjlpd.com

1.2 Background

Castco Testing Centre Ltd. was appointed by *KJL Limited* as their Utility Specialist Contractor to carry out *Manhole Internal Condition Survey (MHICS) at Wing Kin Road, Kwai Chung.*

1.3 Scope of Survey

The work under this contract aims to evaluate the internal condition of manhole at Wing Kin Road for client's design and construction. The result of manhole survey shall be treated as a reliable base for manhole rehabilitation work including repairing structural defects, satisfying maintenance requirements and eliminating inflow and infiltration.

The service of works shall include all administration and management and field works on all aspects of the utility investigation works within the survey area to identify and locate specified ground and underground utilities, it can be summarized as followed:

Part A - Preparation and operation

1. To preliminary study the site condition and to propose for methods to be adopted
2. To coordinate and liaise with client and other parties involved if needed
3. To carry out Manhole Survey by assets identified within the survey extent with the latest available information from various sources including reconnaissance survey, manhole survey and pipeline investigations (Detailed Methodology is presented in Appendix D – Survey Methodology)
4. QA/QC checks to be conducted by the Project Manager and Survey Crew Leader in house and on site
5. All results generated shall be reviewed and checked by the Project Manager

Part B - Reporting

1. To submit preliminary survey drawing and relevant information if requested to present preliminary result in the interim data analysis period
2. To submit final survey report with drawing to present overall survey result
3. To attend the meeting by our project manager to keep client and consultant updated about the survey progress and preliminary result

2. SURVEY DETAILS AND SITE DESCRIPTION

Details of survey and site location are shown in *Table 2.1 – Details of Survey*.

Table 2.1 – Details of Survey

Surveyed Location:	Wing Kin Road (<i>Figure 2.1</i>)
Crew Leader:	Mr. C. F. WONG
Survey Duration of Utility Survey:	18 th June, 2022



Figure 2.1 – Location plan (Source: CentaMap)

3. SUMMARY OF SURVEY RESULTS

There are 5 visible manholes including 0 Storm water manholes and 5 Foul Water Manholes within the survey boundary and 5 no. of manholes had been inspected. Survey location plan has been enclosed in *Appendix A – Survey Result Drawing* to present the manholes location and relevant connections. The summary of manhole survey with specified findings is shown in *Table 3.1 - Summary of Manhole Survey*. Due to the limitation of the condition of site, some of manholes may not be located, inspected satisfactorily or only inspected partially, the reasons or site conditions causing in comprehensive result will be briefed in *Table 3.1* as well. More detailed manholes information about its conditions, dimensions and photo records can be found in Manhole Record Forms in *Appendix B – Manhole Record Forms*.

Table 3.1 – Summary of Manhole Survey

No.	Manhole Ref.	Service Type	Manhole Record Form in Appendix D	Specified findings
1.	FMH4022768	Foul	Y	Broken chamber
2.	FMH4022810	Foul	Y	Broken shaft
3.	FMH4022809	Foul	Y	Broken chamber, benching and iron (4 nos.)
4.	FMH4022808	Foul	Y	Broken benching
5.	FMH4022807	Foul	Y	Broken iron (2 nos.)

4. REFERENCES

- ETWB, 2006, Code of Practice on Monitoring and Maintenance of Water-Carrying Services Affecting Slopes
- Wong King & R.J. Allen, Hong Kong Conduit Condition Evaluation Codes, HKCCEC 2009 (4th Edition), UTI. The Code of Practice on Conduit Condition Evaluation using CCTV in Hong Kong
- Hong Kong Institute of Utility Specialists, Specification for Conduit Condition Evaluation, CCE (CCTV&ME), 2011 Edition
- Hong Kong Institute of Utility Specialists, Specification for Manhole Internal Condition Survey (MHICS), 2011 Edition

5. JOB REFERENCES¹

- SSE517 – Underground Utility Survey for Construction of a 30-Classroom Secondary School at Site 1A-2, Kai Tak Development – Architectural Services Department
- SSF513 – Underground Utility Survey for Construction of Avenue Park at Kai Tak – Architectural Services Department
- SSF516 – Underground Utility Survey for Construction of a 30-Classroom Primary School at Tonkin Street, Cheung Sha Wan – Architectural Services Department
- HY/2014/09 – Underground Utility Survey for Central Kowloon Route – Ho Man Tin Access Shaft – Highways Department
- K&T C1 of 2017 – Term Contract for Site Investigation for DMW Project in Kwai Tsing (2017-18) – Home Affairs Department
- K&T C2 of 2018 – Term Contract for Site Investigation for DMW Project in Kwai Tsing (2018-19) – Home Affairs Department
- 20150364 – Underground Utility Survey at Construction of Public Rental Housing Development at Choi Yuen Road Site 3 & 4, Sheung Shui – Hong Kong Housing Authority
- 20160605 – Underground Utility Survey for Construction of Public Rental Housing Development of Tung Tau Estate Phase 8 – Hong Kong Housing Authority
- 20170225 – Construction of Public Rental Housing Development Phases 1 & 2 and Subsidised Sale Flats Development at Diamond Hill Comprehensive Development Area – Hong Kong Housing Authority
- 15/WSD/10 – Underground Utility Survey for Expansion of Tai Po Water Treatment Works and Ancillary Raw Water and Fresh Water Transfer Facilities - Design and Build of New Stream II – Water Supplies Department

¹ Only Part of Job References was presented, Full Job References could be provided if requested.

APPENDIX A – SURVEY RESULT DRAWING



- GENERAL NOTES :**
- Unit of depth is in metres (m), indicated as #d.
 - Unit of diameter of pipes/cables is in millimeter (mm), indicated as #0.
 - Symbols are indicative, and not to scale.
 - Coordinates and Levels are according to the Hong Kong 1980 Grid System and the Hong Kong Principal Datum (HKPD).
 - Width of the line in the drawing is not representing the actual size of pipes/cables or the width of cables' bundle. Actual width is presented in the table 'Summary of Pipes & Cables'.
 - The assigned number of each utility alignments with its cable's/pipe's size, range of depth, reference point of presented pipe/cable's depth and remarks for additional information are summarized and shown in the table 'Summary of Pipes & Cables' on the drawing.
 - The assigned number of each utility manholes, pits, valves or gullies with its Cover Level (C.L.) in Metres above Principal Datum (m.P.D.), Invert Level (I.L.), depth and remarks for additional information are summarized and shown in the table 'Summary of Manholes, Pits & Valves' on the drawing.
 - The basemap feature is for reference only, additional topographic survey should be carried out if detailed topographical features on ground requested.
 - The size of Pipes/Manholes/Pits/Chambers is from the internal dimension; its thickness is not counted.
 - Survey report shall be reviewed with drawing together as comprehensive survey result presentation.
 - Alignment of power cable located by passive detection is for reference only. Depth measurement from this detection mode is not accurate and should not be relied on. The Electricity Supply Lines (Protection) Regulation requires that all reasonable steps including trial pit shall be taken to ascertain the existence of these electricity cables or lines.

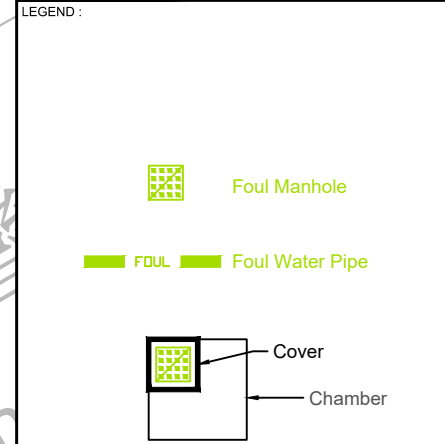

Rev.	Date	Drawn by	Description
00	06/2022	Ki Ho	First Issue

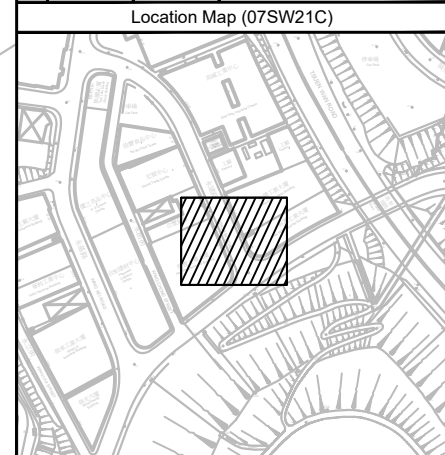

PROJECT CLIENT :

KJL Limited

SPECIALIST CONTRACTOR :

CASTCO
 佳力高試驗中心有限公司
 CASTCO TESTING CENTRE LTD.
 Tel: (852) 2597-8333 / 2597-8002 Fax: (852) 2597-8399/ 2602-3662
 E-mail: info@castco.com.hk Website: http://www.castco.com.hk

PROJECT TITLE :

Manhole Internal Condition Survey
 at Wing Kin Road

DRAWING TITLE : Manhole Survey Drawing

A3 Size	Scale: 1:100	Survey Date	June 2022
Prepared By	Pinky Lee	Approved By	Pinky Lee
Project No.	Y22-US-P-103-002		
Drawing No.	Y22-US-P-103-002-D_00		

Sheet 1 of 1

APPENDIX B – MANHOLE RECORD FORMS

(6) PROJECT NO. 項目序號	Y22-US-P-103-002		(9) DSD REF. 業務署編號	FMH4022768			(1) NODE REF. 井序號	FMH4022768		
(7) WO NO. 工作單號	--					(2) GRID REF. E	N	824325.801	E	830368.466
(10) LOCATION 位置	Wing Kin Road						(3) DRAINAGE AREA CODE	07SW21C		
(11) YEAR LAID 何時造(YYYY)	Unknown		(12) STATUS 狀況*	PU	(13) FUNCTION 用途*	F	(14) NODE TYPE 類別*	M	(4) SURVEYED BY	C. F. WONG
COVER 井蓋	(15) SHAPE 井蓋形狀	S	(16) HINGED 數	N	(17) LOCK 鎖	N	(18) DUTY 井蓋厚度*	H	(5) SURVEY DATE (DD/MM/YYYY)	18/6/2022
SHAFT 井頭	(20) SIDE ENTRY 側邊入口	N	(21) REGULAR COURSES 磚	0	(22) DEPTH 井頭深(mm)	615	(19) COVER SIZE 井蓋大小	580 X 580	(23) SHAFT SIZE 井頭大小	575 X 575
CHAMBER 井體	(24) SOFFIT 牆頂形狀*	S	(25) STEPS 腳踏級數	4	(26) LADDERS 爬梯級數	0	(27) LNDGS 平台層數	0	(28) CHAMBER SIZE 井體大小	1980 X 1510
								(29) TOXIC ATMOSPHERE 毒氣	N	
								(30) EVIDENCE OF VERMIN 蟲害	N	
								(31) CONSTRUCT CODE 建築方法*	I	

(32) DEPTH OF FLOW 水流深 (mm)	300	(33) DEPTH OF SILT 泥深 (mm)	250	(34) HEIGHT SURCH 浸水深 (mm)	0	(61) MH DEPTH 井深 (m)	2.805	(35) COVER LEVEL (mPD)	7.391
--------------------------------	-----	-------------------------------	-----	-------------------------------	---	-------------------------	-------	---------------------------	-------

	(36) UPSTREAM REF. 上游井編號	(37) PIPE SHAPE* 渠筒形狀	(38) PIPE SIZE 渠筒大小 (dia. \ W) (mm)	(39) BACKDROP 跌級 (mm)	(40) PIPE MATERIAL* 物料	(41) LINING 內補	(42) PIPE DEPTH 渠筒底深 (m)	(43) INVERT LEVEL (m)
A	FMH4022767	C	225 X		CO	N	2.715	4.674
B	FMH4022810	C	400 X		VC	N	2.375	5.014
C	FMH4052921	C	300(270) X		LINING	Y	2.105	5.284
D			X					
E			X					
F			X					
G			X					
H			X					

	(36) DOWNSTREAM REF. 下游井編號	(44) CCTV COND 是否做過CCTV
X	FMH4022769	C
Y		X

CONDITIONS 有損壞 (Y if attention required)	(46) COVER 井蓋	N	(47) IRON/ LADDER 腳路/爬梯/平台	N	(48) SHAFT 井頭	N	(49) CHAMBER 井體	Y	(50) BENCHING 馬枕	N	(51) OTHER 其他	N
(52) PHOTO NO.	--		--		--		P7-8		--		--	

(53) UTR	N	(59) LOACTION PHOTO No. 位置相	P1	(63) REMARKS Broken chamber. Cover level of lowest reference point for manhole measurement is 7.389mPD.
(54) UTL	N	(60) INTERNAL PHOTO No. 內部相	P2-6	
(55) UTGA	N	(64) RECORD PLAN DIFFERENCE 測量結果與已有資料不同	Y	
(56) UTS	N	(65) COVER TYPE		
(57) JETTING	N	(66) SLOPE NO 斜坡編號: (If slope involved in project)	--	STANDARD LARGE 大二人井
(58) ON-SLOPE 位於斜坡	N			MULTIPLE COVER 九宮格
				LARGE 四人井
				WITH DECORATION COVER 裝飾蓋
				OTHERS: ()

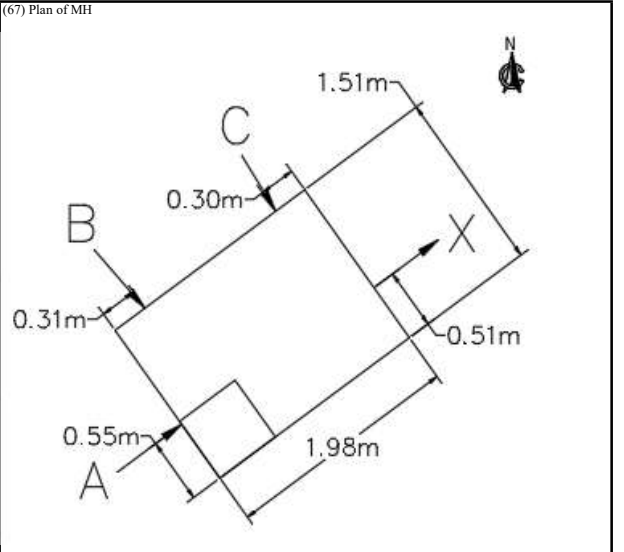
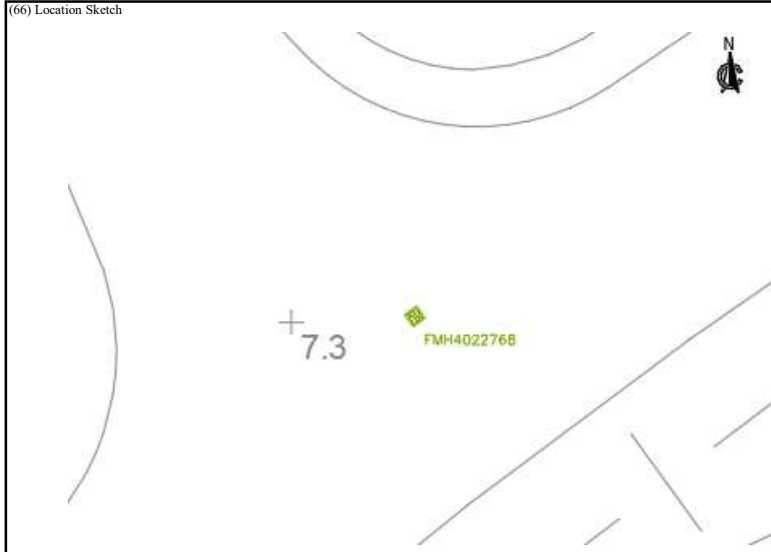

(68) With Risk Assessment	N
(69) With Permit to Work	N
(70) With Traffic Permit	N

Contract No.: Y22-US-P-103-002

Location: Wing Kin Road



Photograph No. :
FMH4022768 -P1

Location :
Wing Kin Road

Manhole Reference :
FMH4022768

Description :
Manhole Location Photo

Remark :



Photograph No. :
FMH4022768 -P2

Location :
Wing Kin Road

Manhole Reference :
FMH4022768

Description :
Internal Condition Photo

Remark :

Contract No.: Y22-US-P-103-002

Location: Wing Kin Road



新界葵涌荃灣路
A

Photograph No. :	FMH4022768 -P3
Location :	Wing Kin Road
Manhole Reference :	FMH4022768
Description :	Internal Condition Photo
Remark :	Incoming pipe A



新界葵涌荃灣路
B

Photograph No. :	FMH4022768 -P4
Location :	Wing Kin Road
Manhole Reference :	FMH4022768
Description :	Internal Condition Photo
Remark :	Incoming pipe B

Contract No.: Y22-US-P-103-002

Location: Wing Kin Road



新界葵涌永建路
C

Photograph No. :
FMH4022768 -P5

Location :
Wing Kin Road

Manhole Reference :
FMH4022768

Description :
Internal Condition Photo

Remark :
Incoming pipe C



新界葵涌荃灣路
X

Photograph No. :
FMH4022768 -P6

Location :
Wing Kin Road

Manhole Reference :
FMH4022768

Description :
Internal Condition Photo

Remark :
Outgoing pipe X

Contract No.: Y22-US-P-103-002

Location: Wing Kin Road



新界葵涌荃灣路
X

Photograph No. :
FMH4022768 -P7

Location :
Wing Kin Road

Manhole Reference :
FMH4022768

Description :
Internal Condition Photo

Remark :
Broken chamber



新界葵涌荃灣路
B

Photograph No. :
FMH4022768 -P8

Location :
Wing Kin Road

Manhole Reference :
FMH4022768

Description :
Internal Condition Photo

Remark :
Broken chamber

(6) PROJECT NO. 項目序號	Y22-US-P-103-002		(9) DSD REF. 渠務署編號	FMH4022810			(1) NODE REF. 井序號	FMH4022810		
(7) WO NO. 工作單號	--					(2) GRID REF. E	N	824332.557		
(10) LOCATION 位置	Wing Kin Road						(3) DRAINAGE AREA CODE	07SW21C		
(11) YEAR LAID 何時造(YYYY)	Unknown		(12) STATUS 狀況*	PU	(13) FUNCTION 用途*	F	(14) NODE TYPE 類別*	M	(4) SURVEYED BY	C. F. WONG
COVER 井蓋	(15) SHAPE 井蓋形狀	S	(16) HINGED 鉸	N	(17) LOCK 鎖	N	(18) DUTY 井蓋厚度*	H	(5) SURVEY DATE (DD/MM/YYYY)	18/6/2022
SHAFT 井頭	(20) SIDE ENTRY 側邊入口	N	(21) REGULAR COURSES 磚	0	(22) DEPTH 井頭深(mm)	745	(19) COVER SIZE 井蓋大小	580 X 580	(29) TOXIC ATMOSPHERE 毒氣	N
CHAMBER 井體	(24) SOFFIT 牆頂形狀*	S	(25) STEPS 腳踏級數	3	(26) LADDERS 爬梯級數	0	(27) LNDGS 平台層數	0	(28) CHAMBER SIZE 井體大小	980 X 1260
			(30) EVIDENCE OF VERMIN 蟲否				(23) SHAFT SIZE 井頭大小	570 X 550	(31) CONSTRUCT CODE 建築方法*	I

(32) DEPTH OF FLOW 水流深 (mm)	300	(33) DEPTH OF SILT 泥深 (mm)	0	(34) HEIGHT SURCH 浸水深 (mm)	0	(61) MH DEPTH 井深 (m)	2.419	(35) COVER LEVEL (mPD)	7.540
--------------------------------	-----	-------------------------------	---	-------------------------------	---	-------------------------	-------	---------------------------	-------

	(36) UPSTREAM REF. 上游井編號	(37) PIPE SHAPE* 渠筒形狀	(38) PIPE SIZE 渠筒大小 (dia. \ W) (mm)	(39) BACKDROP 跌級 (mm)	(40) PIPE MATERIAL* 物料	(41) LINING 內補	(42) PIPE DEPTH 渠筒底深 (m)	(43) INVERT LEVEL (m)
A	FMH4022809	C	400 X		VC	N	2.418	5.106
B			X					
C			X					
D			X					
E			X					
F			X					
G			X					
H			X					

	(36) DOWNSTREAM REF. 下游井編號	(37) PIPE SHAPE* 渠筒形狀	(38) PIPE SIZE 渠筒大小 (dia. \ W) (mm)	(39) BACKDROP 跌級 (mm)	(40) PIPE MATERIAL* 物料	(41) LINING 內補	(42) PIPE DEPTH 渠筒底深 (m)	(43) INVERT LEVEL (m)
X	FMH4022768	C	400 X		VC	N	2.419	5.105
Y			X					

CONDITIONS 有損壞 (Y if attention required)	(46) COVER 井蓋	N	(47) IRON/ LADDER 腳路/爬梯/平台	N	(48) SHAFT 井頭	Y	(49) CHAMBER 井體	N	(50) BENCHING 馬枕	N	(51) OTHER 其他	N
(52) PHOTO NO.	--		--		P5		--		--		--	

(53) UTR	N	(59) LOACTION PHOTO No. 位置相	P1	(63) REMARKS Broken shaft. Cover level of lowest reference point for manhole measurement is 7.524mPD.
(54) UTL	N	(60) INTERNAL PHOTO No. 內部相	P2-4	
(55) UTGA	N	(64) RECORD PLAN DIFFERENCE 測量結果與已有資料不同	N	
(56) UTS	N	(65) COVER TYPE		
(57) JETTING	N	(66) ON-SLOPE 位於斜坡	--	
(58) ON-SLOPE 位於斜坡	N	(67) COVER TYPE		

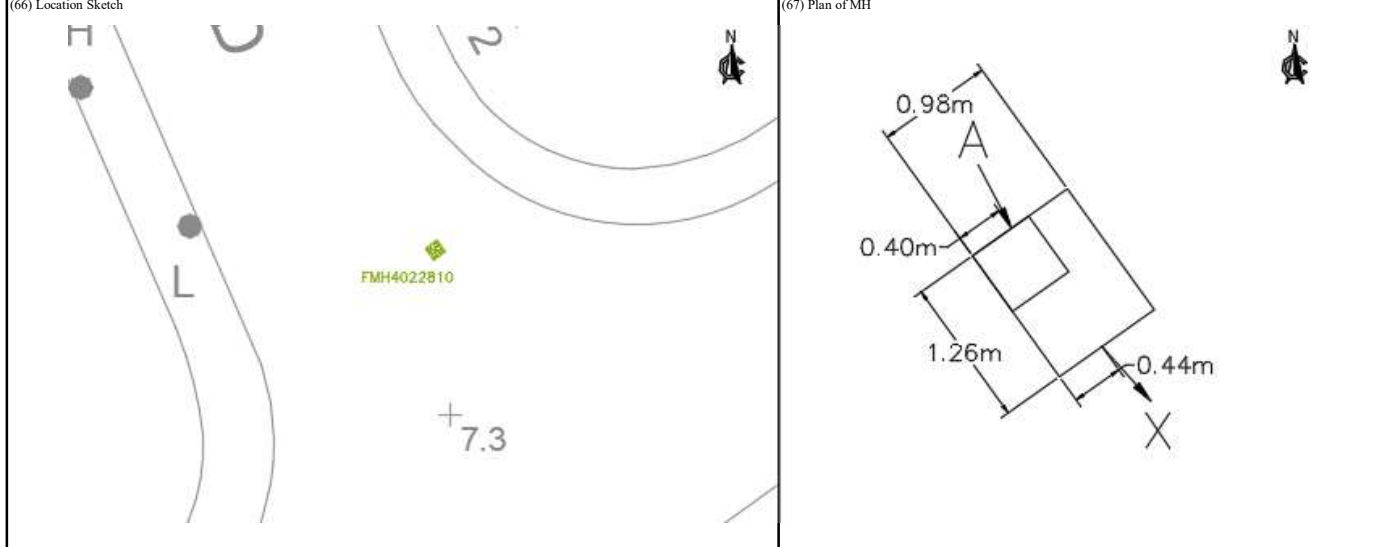

(68) With Risk Assessment	N
(69) With Permit to Work	N
(70) With Traffic Permit	N

Contract No.: Y22-US-P-103-002

Location: Wing Kin Road



Photograph No. :	FMH4022810 -P1
Location :	Wing Kin Road
Manhole Reference :	FMH4022810
Description :	Manhole Location Photo
Remark :	



Photograph No. :	FMH4022810 -P2
Location :	Wing Kin Road
Manhole Reference :	FMH4022810
Description :	Internal Condition Photo
Remark :	

Contract No.: Y22-US-P-103-002

Location: Wing Kin Road



新界葵涌永建路
A

Photograph No. :	FMH4022810 -P3
Location :	Wing Kin Road
Manhole Reference :	FMH4022810
Description :	Internal Condition Photo
Remark :	Incoming pipe A



新界葵涌永建路
X

Photograph No. :	FMH4022810 -P4
Location :	Wing Kin Road
Manhole Reference :	FMH4022810
Description :	Internal Condition Photo
Remark :	Outgoing pipe X

Contract No.: Y22-US-P-103-002

Location: Wing Kin Road



Photograph No. :	FMH4022810 -P5
Location :	Wing Kin Road
Manhole Reference :	FMH4022810
Description :	Internal Condition Photo
Remark :	Broken shaft

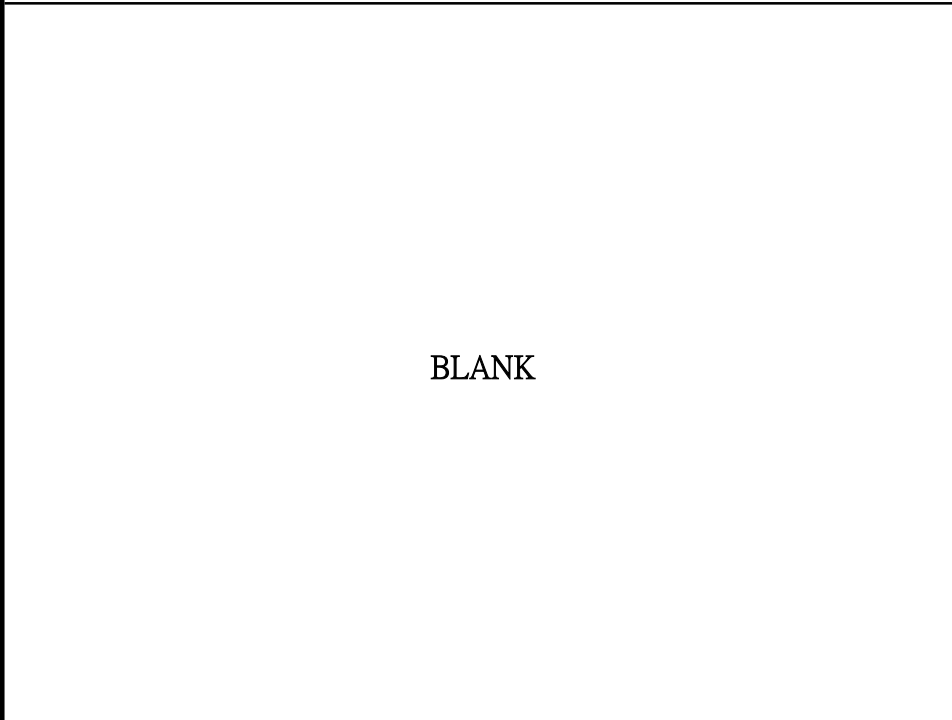

Photograph No. :	
Location :	
Manhole Reference :	
Description :	
Remark :	

(6) PROJECT NO. 項目序號	Y22-US-P-103-002		(9) DSD REF. 渠務署編號	FMH4022809			(1) NODE REF. 井序號	FMH4022809		
(7) WO NO. 工作單號	--					(2) GRID REF. E	N	824344.777		
(10) LOCATION 位置	Wing Kin Road						(3) DRAINAGE AREA CODE	07SW21C		
(11) YEAR LAID 何時造(YYYY)	Unknown		(12) STATUS 狀況*	PU	(13) FUNCTION 用途*	F	(14) NODE TYPE 類別*	M	(4) SURVEYED BY	C. F. WONG
COVER 井蓋	(15) SHAPE 井蓋形狀	S	(16) HINGED 鉸	N	(17) LOCK 鎖	N	(18) DUTY 井蓋厚度*	H	(5) SURVEY DATE (DD/MM/YYYY)	18/6/2022
SHAFT 井頭	(20) SIDE ENTRY 側邊入口	N	(21) REGULAR COURSES 磚	20	(22) DEPTH 井頭深(mm)	505	(19) COVER SIZE 井蓋大小	580 X 580	(23) SHAFT SIZE 井頭大小	600 X 610
CHAMBER 井腔	(24) SOFFIT 腳頂形狀*	S	(25) STEPS 腳踏級數	4	(26) LADDERS 爬梯級數	0	(27) LNDGS 平台層數	0	(28) CHAMBER SIZE 井腔大小	1365 X 955
			(29) TOXIC ATMOSPHERE 毒氣	N					(30) EVIDENCE OF VERMIN 蟲舌	N
			(31) CONSTRUCT CODE 建築方法*	I						

(32) DEPTH OF FLOW 水流深 (mm)	300	(33) DEPTH OF SILT 泥深 (mm)	0	(34) HEIGHT SURCH 浸水深 (mm)	0	(61) MH DEPTH 井深 (m)	2.545	(35) COVER LEVEL (mPD)	8.163
--------------------------------	-----	-------------------------------	---	-------------------------------	---	-------------------------	-------	---------------------------	-------

	(36) UPSTREAM REF. 上游井編號	(37) PIPE SHAPE* 渠筒形狀	(38) PIPE SIZE 渠筒大小 (dia. \ W) (mm)	(39) BACKDROP 跌級 (mm)	(40) PIPE MATERIAL* 物料	(41) LINING 內補	(42) PIPE DEPTH 渠筒底深 (m)	(43) INVERT LEVEL (m)
A	FMH4022808	C	400 X		VC	N	2.460	5.682
B	GNB	C	150 X		VC	N	1.725	6.417
C			X					
D			X					
E			X					
F			X					
G			X					
H			X					

	(36) DOWNSTREAM REF. 下游井編號	(37) PIPE SHAPE* 渠筒形狀	(38) PIPE SIZE 渠筒大小 (dia. \ W) (mm)	(39) BACKDROP 跌級 (mm)	(40) PIPE MATERIAL* 物料	(41) LINING 內補	(42) PIPE DEPTH 渠筒底深 (m)	(43) INVERT LEVEL (m)
X	FMH4022810	C	400 X		VC	N	2.545	5.597
Y			X					

CONDITIONS 有損壞 (Y if attention required)	(46) COVER 井蓋	N	(47) IRON/ LADDER 腳路/爬梯/平台	Y	(48) SHAFT 井頭	N	(49) CHAMBER 井腔	Y	(50) BENCHING 馬枕	Y	(51) OTHER 其他	N
(52) PHOTO NO.	--		P6		--		P8		P7		--	

(53) UTR	N	(59) LOACTION PHOTO No. 位置相	P1	(63) REMARKS	Broken, chamber, benching and iron (4 nos.). Cover level of lowest reference point for manhole measurement is 8.142mPD.		
(54) UTL	N	(60) INTERNAL PHOTO No. 內部相	P2-5	(64) RECORD PLAN DIFFERENCE 測量結果與已有資料不同	Y	(Y if attention required) 如有:- GNB is a 150mm dia Outgoing pipe instead of 225mm dia indicated in record plan.	
(55) UTGA	N	(65) COVER TYPE		STANDARD 一人井 / LARGE 大二人井 / MULTIPLE COVER 九格 / LARGE 四人井 / WITH DECORATION COVER 裝飾蓋 / OTHERS: ()			
(56) UTS	N	(66) ON-SLOPE 位於斜坡	N				
(57) JETTING	N	(67) Location Sketch		(67) Plan of MH			

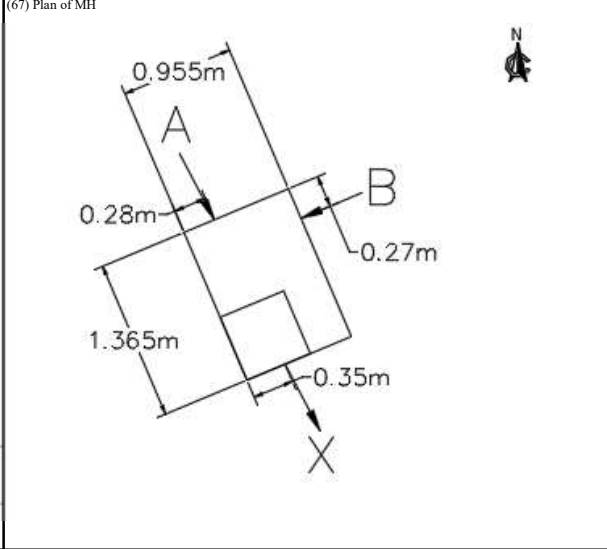
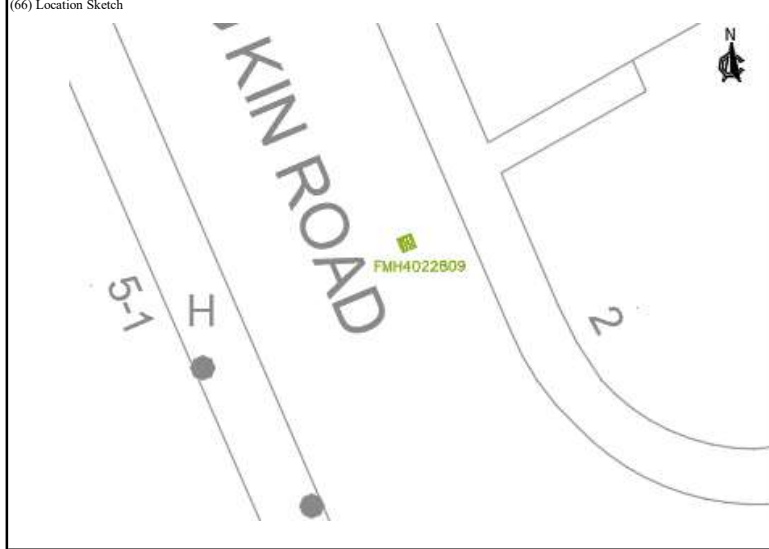

(68) With Risk Assessment	N
(69) With Permit to Work	N
(70) With Traffic Permit	N

Contract No.: Y22-US-P-103-002

Location: Wing Kin Road



Photograph No. :	FMH4022809 -P1
Location :	Wing Kin Road
Manhole Reference :	FMH4022809
Description :	Manhole Location Photo
Remark :	

2022年6月18日
FMH4022809



Photograph No. :	FMH4022809 -P2
Location :	Wing Kin Road
Manhole Reference :	FMH4022809
Description :	Internal Condition Photo
Remark :	

2022年6月18日
FMH4022809

Contract No.: Y22-US-P-103-002

Location: Wing Kin Road



Photograph No. :	FMH4022809 -P3
Location :	Wing Kin Road
Manhole Reference :	FMH4022809
Description :	Internal Condition Photo
Remark :	Incoming pipe A



Photograph No. :	FMH4022809 -P4
Location :	Wing Kin Road
Manhole Reference :	FMH4022809
Description :	Internal Condition Photo
Remark :	Incoming pipe B

Contract No.: Y22-US-P-103-002

Location: Wing Kin Road



Photograph No. :	FMH4022809 -P5
Location :	Wing Kin Road
Manhole Reference :	FMH4022809
Description :	Internal Condition Photo
Remark :	Outgoing pipe X



Photograph No. :	FMH4022809 -P6
Location :	Wing Kin Road
Manhole Reference :	FMH4022809
Description :	Internal Condition Photo
Remark :	Broken iron

Contract No.: Y22-US-P-103-002

Location: Wing Kin Road



Photograph No. :
FMH4022809 -P7

Location :
Wing Kin Road

Manhole Reference :
FMH4022809

Description :
Internal Condition Photo

Remark :
Broken benching



Photograph No. :
FMH4022809 -P8

Location :
Wing Kin Road

Manhole Reference :
FMH4022809

Description :
Internal Condition Photo

Remark :
Broken chamber

(6) PROJECT NO. 項目序號	Y22-US-P-103-002		(9) DSD REF. 渠務署編號	FMH4022808			(1) NODE REF. 井序號	FMH4022808		
(7) WO NO. 工作單號	--					(2) GRID REF. E	N	824354.119	830351.744	
(10) LOCATION 位置	Wing Kin Road						(3) DRAINAGE AREA CODE	07SW21C		
(11) YEAR LAID 何時造(YYYY)	Unknown		(12) STATUS 狀況*	PU	(13) FUNCTION 用途*	F	(14) NODE TYPE 類別*	M	(4) SURVEYED BY	C. F. WONG
COVER 井蓋	(15) SHAPE 井蓋形狀	S	(16) HINGED 數	N	(17) LOCK 鎖	N	(18) DUTY 井蓋厚度*	H	(5) SURVEY DATE (DD/MM/YYYY)	18/6/2022
SHAFT 井頭	(20) SIDE ENTRY 側邊入口	N	(21) REGULAR COURSES 磚	5	(22) DEPTH 井頭深(mm)	450	(19) COVER SIZE 井蓋大小	580 X 580	(23) SHAFT SIZE 井頭大小	555 X 550
CHAMBER 井腔	(24) SOFFIT 牆頂形狀*	S	(25) STEPS 腳踏級數	3	(26) LADDERS 爬梯級數	0	(27) LNDGS 平台層數	0	(28) CHAMBER SIZE 井腔大小	990 X 1400

(32) DEPTH OF FLOW 水流深 (mm)	300	(33) DEPTH OF SILT 泥深 (mm)	0	(34) HEIGHT SURCH 浸水深 (mm)	0	(61) MH DEPTH 井深 (m)	2.600	(35) COVER LEVEL (mPD)	8.712
(36) UPSTREAM REF. 上游井編號	FMH4022807	(37) PIPE SHAPE* 渠筒形狀	C	(38) PIPE SIZE 渠筒大小 (dia. \ W) (mm)	400 X	(39) BACKDROP 跌級 (mm)		(40) PIPE MATERIAL* 物料	VC
(41) LINING 內補	N	(42) PIPE DEPTH 渠筒底深 (m)	2.510	(43) INVERT LEVEL (m)	6.176	(44) CCTV COND 是否做過CCTV		(45) OTHER	N

	(36) DOWNSTREAM REF. 下游井編號	(37) PIPE SHAPE*	(38) PIPE SIZE 渠筒大小 (dia. \ W) (mm)	(39) BACKDROP 跌級 (mm)	(40) PIPE MATERIAL* 物料	(41) LINING 內補	(42) PIPE DEPTH 渠筒底深 (m)	(43) INVERT LEVEL (m)
A	FMH4022807	C	400 X		VC	N	2.510	6.176
B	GNB	C	225 X		VC	N	1.884	6.802
C	FMH4022812	C	300(250) X		LINING	Y	2.502	6.184
D			X					
E			X					
F			X					
G			X					
H			X					

(46) COVER 井蓋	N	(47) IRON/ LADDER 腳路/爬梯/平台	N	(48) SHAFT 井頭	N	(49) CHAMBER 井腔	N	(50) BENCHING 馬枕	Y	(51) OTHER 其他	N
(52) PHOTO NO.	--		--		--		--	P7		--	

(53) UTR	N	(59) LOACTION PHOTO No. 位置相	P1	(63) REMARKS	Broken benching. Cover level of lowest reference point for manhole measurement is 8.686mPD.	
(54) UTL	N	(60) INTERNAL PHOTO No. 內部相	P2-6	(64) RECORD PLAN DIFFERENCE 測量結果與已有資料不同	N	(Y if attention required) 如有:
(55) UTGA	N	(65) COVER TYPE		STANDARD- LARGE 大二人井 MULTIPLE COVER 九格 LARGE COVER 四人井 WITH DECORATION COVER 裝飾蓋 OTHERS: ()		
(56) UTS	N	(66) LOCATION SKETCH		(67) PLAN OF MH		
(57) JETTING	N	(68) WITH RISK ASSESSMENT	N			
(58) ON-SLOPE 位於斜坡	N	(69) WITH PERMIT TO WORK	N			
		(70) WITH TRAFFIC PERMIT	N			

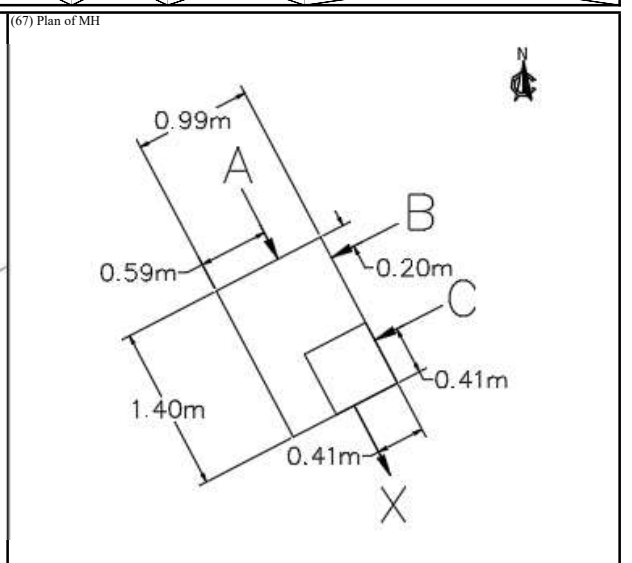

(68) With Risk Assessment	N
(69) With Permit to Work	N
(70) With Traffic Permit	N

Contract No.: Y22-US-P-103-002

Location: Wing Kin Road



Photograph No. :	FMH4022808 -P1
Location :	Wing Kin Road
Manhole Reference :	FMH4022808
Description :	Manhole Location Photo
Remark :	



Photograph No. :	FMH4022808 -P2
Location :	Wing Kin Road
Manhole Reference :	FMH4022808
Description :	Internal Condition Photo
Remark :	

Contract No.: Y22-US-P-103-002

Location: Wing Kin Road



新界葵涌永建路
A

Photograph No. :	FMH4022808 -P3
Location :	Wing Kin Road
Manhole Reference :	FMH4022808
Description :	Internal Condition Photo
Remark :	Incoming pipe A



新界葵涌永建路
B

Photograph No. :	FMH4022808 -P4
Location :	Wing Kin Road
Manhole Reference :	FMH4022808
Description :	Internal Condition Photo
Remark :	Incoming pipe B

Contract No.: Y22-US-P-103-002

Location: Wing Kin Road



新界葵涌永建路
C

Photograph No. :	FMH4022808 -P5
Location :	Wing Kin Road
Manhole Reference :	FMH4022808
Description :	Internal Condition Photo
Remark :	Incoming pipe C



新界葵涌永建路
X

Photograph No. :	FMH4022808 -P6
Location :	Wing Kin Road
Manhole Reference :	FMH4022808
Description :	Internal Condition Photo
Remark :	Outgoing pipe X

Contract No.: Y22-US-P-103-002

Location: Wing Kin Road



Photograph No. :	FMH4022808 -P7
Location :	Wing Kin Road
Manhole Reference :	FMH4022808
Description :	Internal Condition Photo
Remark :	Broken benching

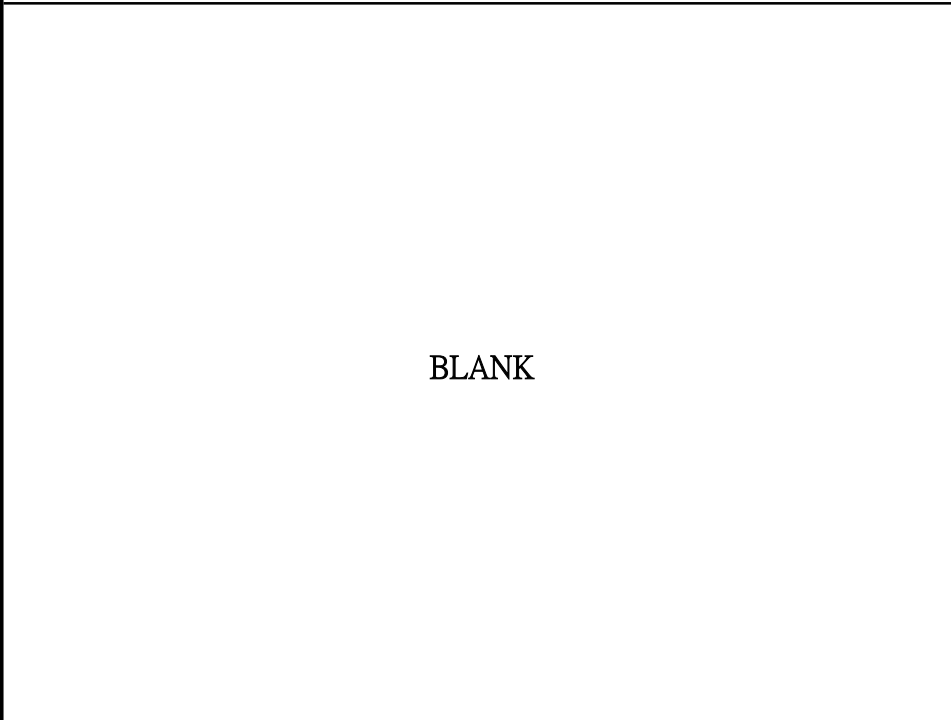

Photograph No. :	
Location :	
Manhole Reference :	
Description :	
Remark :	

(6) PROJECT NO. 項目序號	Y22-US-P-103-002		(9) DSD REF. 渠務署編號	FMH4022807			(1) NODE REF. 井序號	FMH4022807		
(7) WO NO. 工作單號	--					(2) GRID REF. E	N	824366.984	830345.076	
(10) LOCATION 位置	Wing Kin Road						(3) DRAINAGE AREA CODE	07SW21C		
(11) YEAR LAID 何時造(YYYY)	Unknown		(12) STATUS 狀況*	PU	(13) FUNCTION 用途*	F	(14) NODE TYPE 類別*	M		
COVER 井蓋	(15) SHAPE 井蓋形狀	S	(16) HINGED 銹	N	(17) LOCK 鎖	N	(18) DUTY 井蓋厚度*	H		
SHAFT 井頭	(20) SIDE ENTRY 側邊入口	N	(21) REGULAR COURSES 磚	0	(22) DEPTH 井頭深(mm)	1825		(19) COVER SIZE 井蓋大小	580 X 580	
CHAMBER 井體	(24) SOFFIT 牆頂形狀*	S	(25) STEPS 腳踏級數	4	(26) LADDERS 爬梯級數	0	(27) LNDGS 平台層數	0	(28) CHAMBER SIZE 井體大小	1530 X 1210

(32) DEPTH OF FLOW 水流深 (mm)	300	(33) DEPTH OF SILT 泥深 (mm)	0	(34) HEIGHT SURCH 浸水深(mm)	0	(61) MH DEPTH 井深(m)	3.180	(35) COVER LEVEL (mPD)	9.602
--------------------------------	-----	-------------------------------	---	------------------------------	---	------------------------	-------	---------------------------	-------

	(36) UPSTREAM REF. 上游井編號	(37) PIPE SHAPE* 渠筒形狀	(38) PIPE SIZE 渠筒大小 (dia. \ W) (mm)	(39) BACKDROP 跌級 (mm)	(40) PIPE MATERIAL* 物料	(41) LINING 內補	(42) PIPE DEPTH 渠筒底深(m)	(43) INVERT LEVEL (m)
A	GNA	C	225 X		VC	N	2.825	6.755
B	FMH4052922	C	225 X		VC	N	2.380	7.200
C	GNC	C	150 X		VC	N	1.610	7.970
D			X					
E			X					
F			X					
G			X					
H			X					

	(36) DOWNSTREAM REF. 下游井編號	(44) CCTV COND 是否做過CCTV
X	FMH4022808	C
Y		X

CONDITIONS 有損壞 (Y if attention required)	(46) COVER 井蓋	N	(47) IRON/ LADDER 腳路/爬梯/平台	Y	(48) SHAFT 井頭	N	(49) CHAMBER 井體	N	(50) BENCHING 馬枕	N	(51) OTHER 其他	N
(52) PHOTO NO.	--		P7		--		--		--		--	

(53) UTR	N	(59) LOACTION PHOTO No. 位置相	P1	(63) REMARKS	Broken iron (2 nos.). Cover level of lowest reference point for manhole measurement is 9.580mPD.		
(54) UTL	N	(60) INTERNAL PHOTO No. 內部相	P2-6	(64) RECORD PLAN DIFFERENCE 測量結果與已有資料不同	Y	(Y if attention required) 如有: -Additional one 225mm dia. Incoming pipe A & one 150mm dia. Incoming pipe C in plan of MH existed.	
(55) UTGA	N	(65) COVER TYPE		<input checked="" type="checkbox"/> STANDARD-LARGE 大二人井 <input checked="" type="checkbox"/> MULTIPLE COVER 九層格 <input checked="" type="checkbox"/> LARGE 四人井 <input checked="" type="checkbox"/> WITH DECORATION COVER 裝飾蓋 OTHERS: ()			
(56) UTS	N	(66) ON-SLOPE 位於斜坡	--				
(57) JETTING	N						

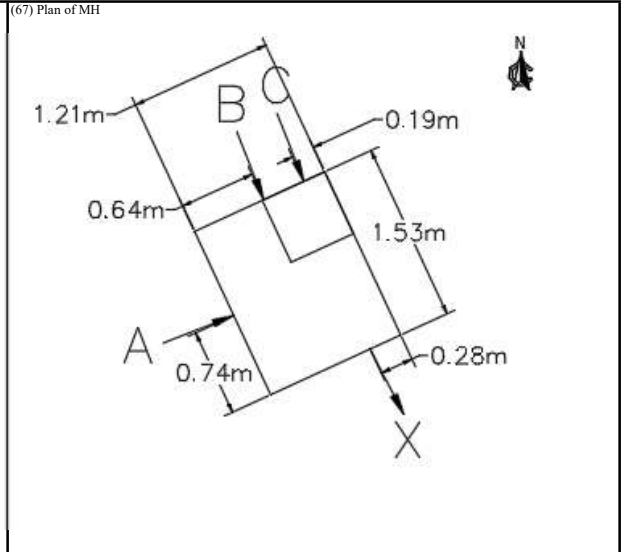

(68) With Risk Assessment	N
(69) With Permit to Work	N
(70) With Traffic Permit	N

Contract No.: Y22-US-P-103-002

Location: Wing Kin Road新界葵涌永建路
FMH4022807

Photograph No. :

FMH4022807 -P1

Location :

Wing Kin Road

Manhole Reference :

FMH4022807

Description :

Manhole Location Photo

Remark :

新界葵涌永建路
FMH4022807

Photograph No. :

FMH4022807 -P2

Location :

Wing Kin Road

Manhole Reference :

FMH4022807

Description :

Internal Condition Photo

Remark :

Contract No.: Y22-US-P-103-002

Location: Wing Kin Road

	Photograph No. : FMH4022807 -P3
	Location : Wing Kin Road
	Manhole Reference : FMH4022807
	Description : Internal Condition Photo
	Remark : Incoming pipe A

	Photograph No. : FMH4022807 -P4
	Location : Wing Kin Road
	Manhole Reference : FMH4022807
	Description : Internal Condition Photo
	Remark : Incoming pipe B

Contract No.: Y22-US-P-103-002

Location: Wing Kin Road

 <p>FMH4022807 PipeC</p> <p>距离: 0.00 m 经度: 0.00 纬度: 0.00</p> <p>06-18-2022 星期六 21</p>	Photograph No. : FMH4022807 -P5
	Location : Wing Kin Road
	Manhole Reference : FMH4022807
	Description : Internal Condition Photo
	Remark : Incoming pipe C

 <p>FMH4022807 PipeX</p> <p>距离: 0.00 m 经度: 0.00 纬度: 0.00</p> <p>06-18-2022 星期六 21</p>	Photograph No. : FMH4022807 -P6
	Location : Wing Kin Road
	Manhole Reference : FMH4022807
	Description : Internal Condition Photo
	Remark : Outgoing pipe X

Contract No.: Y22-US-P-103-002

Location: Wing Kin Road



Photograph No. :	FMH4022807 -P7
Location :	Wing Kin Road
Manhole Reference :	FMH4022807
Description :	Internal Condition Photo
Remark :	Broken iron

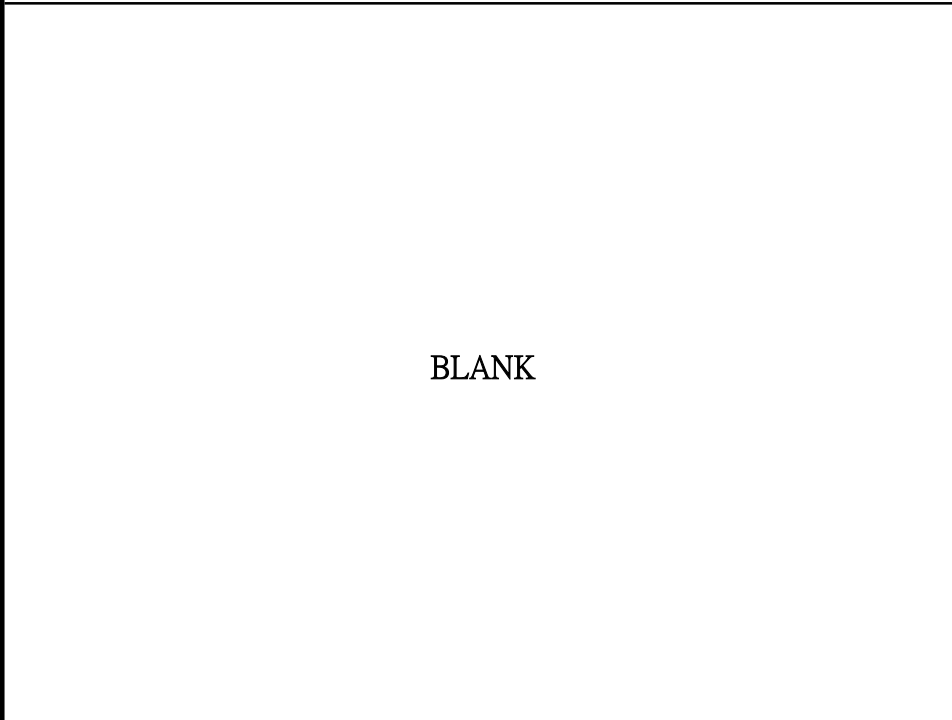

Photograph No. :	
Location :	
Manhole Reference :	
Description :	
Remark :	

APPENDIX C – SURVEY METHODOLOGY

Dimensional Requirements

All dimensions should be measured in accordance with the description stated in **Figure A & B**. Leader should counter check this for accuracy and logicity before leaving the site.

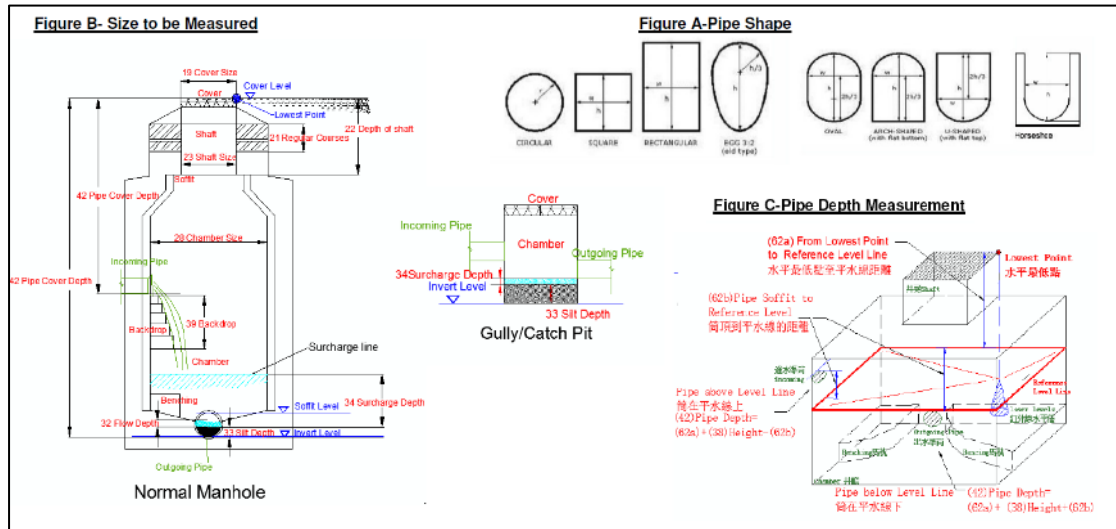

Figure A – Manholes dimensions to be measured

APPENDIX D – QUICK REFERENCE FOR MANHOLE CODES

Quick Reference for Manhole Survey Record Form (Site Record)											
Field No.	Description	Code	Remarks	Field No.	Description	Code	Remarks				
9	DSD Reference	渠務署編號 (井內標牌)	-	井內標牌							
12	Status	井狀況	PU	Public	位於公眾地方	24	Soffit	鐘頂形狀	S	Reducing Slab	平
			PR	Private	位於私人地方				T	Taper	漸尖
			HD	Highway drain	位於高速公路				A	Arch	拱
			WA	Watercourse	位於河道				C	Corbel	斜邊
			TR	Trunk	位於幹渠				N	None	無鐘頂
			U	Unspecified	不清楚				U	Unspecified	不明頂
13	Function	井用途	AB	Abandoned	廢棄	31	Construct Code	井鑄建築方法	B	Brick	磚
			TC	To be constructed	待建				P	Pre-cast Units	預製土預製件
			HC	Housing Committee	房屋署				I	In-Situ	現場鑄造
			WA	Water Company	水務署				S	Segmental	節段
			U	Unspecified	不清楚				R	Rendered	不塗漆
			F	Foul	污水				U	Unspecified	不清楚
14	Node Type	井類別	S	Surface	溝水	37	Pipe Shape	渠筒形狀	A	Arch (with flat-bottom)	拱形 (平底)
			C	Combined	混合				B	Barrel	水桶形
			O	Overflow	溢流				C	Circular	圓形
			U	Unspecified	不清楚				E	Egg	蛋形
			A	Catch Pit	溝沙井				F	U-shaped (with flat-top)	U形 (平頂)
			B	Hydrobrake	攔水牆				H	Horseshoe, inverted	馬蹄鐵形
			C	Cascade	跌水				O	Oval	橢圓形
			D	Dual function Manhole	雙功能井				R	Rectangular	長方形
			E	Ejector	抽水口				S	Square	正方形
			F	Cutfall	溝水口				T	Trapezoidal	梯形
			G	Ghost	假井				U	Unspecified	不明頂
			H	Hatchbox	蓋井				AK	Alkathene	高聚合乙烯
			I	Inlet	明渠入口				AC	Asbestos Cement	石棉
			J	Junction (Saddle)	渠筒對位				BR	Brick	磚
K	Combined	混合	CI	Cast Iron	生鐵						
L	Lamp-hole	燈柱	CO	Concrete	混凝土						
M	Manhol	沙井	CSB	Concrete Segments Bolted	混凝土製分節段 (有螺釘)						
N	Dead End	非正常中斷點	CSU	Concrete Segments	混凝土製分節段 (無螺釘)						
O	Oil Intereceptor	隔油	CC	Concrete Box Culvert	混凝土製方形溝渠						
P	Pumping Station	泵站	DI	Ductile Iron	球墨鑄鐵						
Q	Transition	中線井	GRC	Glass Reinforced	玻璃纖維增強						
R	Rodding eye	疏通蓋	GRP	Glass Reinforced	玻璃纖維增強						
S	Soak-away	污水滲透坑	PSC	Plastic/Steel Composite	塑膠鋼複合材料						
T	Vent Column	沼氣通風柱	PVC	Polyvinyl Chloride	聚氯乙烯						
U	Unspecified	不清楚	PE	Polyethylene	聚乙烯						
V	Storm Overflow	雨水溢流 (教會)	RPM	Reinforced Plastic Matrix	強化塑膠複合材料						
W	Treatment works	污水處理廠	SI	Spun iron	离心鑄鐵柱						
X	Unreliable	不可信	ST	Steel	鋼						
Y	Gully	溝渠	VC	Vitrified Clay	瓦						
Z	Ghost in rising main	假渠壓力管	PP	Polypropylene	聚丙烯						
15	Cover Shape	井蓋形狀	S	Square	正方形	65	Cover Type	井蓋類型	Standard	二人井	820x820mm
			R	Rectangular	長方形				Standard-Large	六人井	980x880mm
			T	Triangular	三角形				Multiple Cover	九宮格	
			D	Dobule Triangular	雙三角				Large	四人井	
			C	Circular	圓形				With Decoration Cover	R裝飾蓋	
U	Unspecified	不明頂	Others	其他							
18	Cover Duty	井蓋厚度	L	Light	輕	21	Regular Courses	磚			
			M	Medium	中						
			H	Heavy	重						
U	Unspecified	不清楚									
21	Regular Courses	磚									

Figure B - Manholes coding

Survey Field Record

The Manhole record card should be filled in by the team leader or by well experienced staff in accordance with the format as shown in **Figure C**



佳力高試驗中心有限公司
CASTCO TESTING CENTRE LTD.

Manhole Record Form

(1) NODE REF 井序號:

(6) PROJECT NO. 項目序號: (9) MSD REF 渠務署編號:

(7) WO NO. 工作單號: (10) LOCATION 位置:

(11) YEAR LAID 埋設年 (YYYY): (12) STATUS 狀況*: (13) PIPE DUCTION*: (14) NODE TYPE 類別*: (4) SURVEYED BY:

(15) SHAPE 井蓋形狀: (16) HINGED 鉸: Y / N (17) LOCK 鎖: Y / N (18) DUTY 井蓋厚度*: (19) COVER SIZE 井蓋大小: (dia.) (mm) (20) TOXIC ATMOSPHERE 有毒氣體: Y / N

(21) SIDE ENTRY 側邊入口: Y / N (22) REGULAR COURSE 定期: (23) DEPTH (m) 深度: (24) SHAFT SIZE 井筒大小: (25) EVIDENCE OF VERMIN 鼠跡: Y / N

(26) SOFFIT 鑲頂形狀*: (27) STEPS 梯級級數: (28) LADDERS 爬梯級數: (29) UNDER 平台層數: (30) CHAMBER SIZE 井室大小: (31) CONSTRUCT CODE 井蓋標識方法:

(32) DEPTH OF FLOW 水流深 (mm): (33) DEPTH OF SILT 泥深 (mm): (34) HEIGHT SURCH 溢水深 (mm): (35) MH DEPTH 井深 (m):

(36) UPSTREAM REF. 上游井編號: (37) PIPE SHAPE* 渠管形狀: (38) PIPE SIZE 渠管大小: (dia. \ W) (mm) (39) BACK DROP 系統: (40) PIPE LANDING 內障: (41) (a) 平水總深度 (b) 渠管到平水總距離 (m): (42) PIPE DEPTH 渠管深度 (m): (71) Photo No. 相片編號: (63) (For office use) Wall No. 牆片編號: Location No. (m):

INCOMING PIPES 流入渠管	A	B	C	D	E	F	G	H	X	Y	(43) CCTV COND 是否合適CCTV	Y / N	(44) (45) (46) (47) (48) (49) (50) (51) OTHER 其他	Y / N	Y / N	Y / N	Y / N	Y / N	Y / N	
									X			Y / N								
									X			Y / N								
									X			Y / N								
									X			Y / N								
									X			Y / N								
									X			Y / N								
									X			Y / N								

(36) DOWNSTREAM REF. 下游井編號: (44) CCTV COND 是否合適CCTV: Y / N

(52) PHOTO NO. 渠管位置相片編號:

(53) UTR 有渠管: Y / N (54) UTIL 井蓋: Y / N (55) UTGA 有渠管: Y / N (56) UTS 井蓋: Y / N (57) SETTING 渠管位置相片編號:

(58) ON-SLOPE 位於斜坡: Y / N (59) LOCATION PHOTO No. 位置相片: (60) INTERNAL 內部: Y / N (61) REMARKS 備註:

(62) RECORD PLAN DIFFERENCE 測量結果與已有資料不同: Y / N (63) COVER TYPE 井蓋類型:

(64) STANDARD 二人井: (65) STANDARD-Large 大二人井: (66) MULTIPLE COVER 九宮格: (67) LARGE COVER 四人井: (68) WITH DECORATION COVER 裝飾蓋: (69) OTHER ():

(70) Location Sketch:

(71) Plan of MH:



(72) With Risk Assessment: Y / N (73) With Permit to Work: Y / N (74) With Traffic Permit: Y / N

Remarks: * - 填寫代碼, 代碼內容見本記錄表格背頁。
需要測量的尺寸類數據定義見本記錄表格背頁 Figure B.

Castco Testing Centre Ltd.
Revision 00 Jan 2016

Manhole Record Form
BDU-Form-103-02

Figure C – Survey form

APPENDIX E – ELECTRONIC COPY OF SURVEY RESULT