

Section 16 Planning Application for Proposed Temporary Cold Storage for Poultry and Distribution Centre for a Period of 3 Years and Filling of Land for Site Formation Works at Lots 471 S.B RP (Part), 472, 473, 474, 475, 476, 482Rp, 483, 484, 486, 487RP, 497S.A.R.P., 501, 502, 504S.B, 505 and 506 S.B RP in D.D. 89 and adjoining Government Land, Man Kam To Road, Sha Ling, New Territories

Ref.:MDPC/SEW/1022/001

## D03 - Sewerage Assessment Report

Lots 471 S.B RP (Part), 472, 473, 474, 475, 476, 482Rp, 483, 484, 486, 487RP, 497S.A.R.P., 501, 502, 504 S.B, 505 and 506 S.B RP in D.D. 89 and adjoining Government Land, Man Kam To Road, Sha Ling, New Territories

Oct 2024

Prepared by

***C&K Land Management Company Limited***

## Table of Contents

<b>1</b>	<b>PROJECT BACKGROUND</b> .....	<b>1-1</b>
1.1	Introduction .....	1-1
1.2	Site Description .....	1-1
1.3	Project Description .....	1-1
1.4	Objectives of this Report .....	1-2
1.5	Reference Materials .....	1-2
<b>2</b>	<b>DESCRIPTION OF EXISTING ENVIRONMENT AND BASELINE CONDITIONS</b> .....	<b>2-1</b>
2.1	Site Location .....	2-1
2.2	Existing Baseline Conditions .....	2-1
2.3	Potential Sewerage Impact .....	2-1
<b>3</b>	<b>SEWERAGE ANALYSIS</b> .....	<b>3-1</b>
3.1	Assumptions and Methodology .....	3-1
3.2	Feasible Options .....	3-1
3.3	Results and Discussion .....	3-1
<b>4</b>	<b>CONCLUSIONS AND RECOMMENDATIONS</b> .....	<b>4-1</b>

## Appendices

### APPENDIX A CATALOGUE OF LOW FLUSH TOILET

## List of Tables

Table 3-1: Estimated On-site Populations .....	3-1
--	-----

## List of Figures

Figure 1-1: Site Location and its Environs .....	1-3
--	-----

# 1 PROJECT BACKGROUND

## 1.1 Introduction

- 1.1.1 Hong Kong Chilled Meat & Poultry Association (“HKCMA” or “the Applicant”) plans to construct and operate a Temporary Cold Storage and Distribution Centre (“the Centre” or “the Proposed Development”) for a period of three years at Lots Lots 471 S.B RP (Part), 472, 473, 474, 475,476, 482Rp, 483, 484, 486, 487RP, 497S.A.R.P.in D.D.89 and adjoining Government Land, Man Kam To Road, Sandy Ridge in New Territories (“the Site”).
- 1.1.2 The Site is currently zoned “Agriculture” (AGR) under the Approved Fu Tei Au and Sha Ling Outline Zoning Plan (“OZP”) No. S/NE-FTA/18. In accordance with paragraph 10(a) of the Explanatory Note of the OZP, temporary use or development of any land or building not exceeding a period of three years would require planning permission from the Town Planning Board (“TPB”). Therefore, a Section 16 Planning Application with an application number A/NE-FTA/201 & A/NE-FTA/220 were made and approved with conditions on 28 May 2021 & 09 November 2023 .
- 1.1.3 In order to provide better design for a more cost-effective of operating the Centre, the following major modifications to the approved planning application have been proposed:
- Changing the Site boundary from 16,060m<sup>2</sup> to 20,249m<sup>2</sup> approximately;
  - Combining Blocks A, B, C into one Main Block;
  - Not Changing the maximum building height keep to 20.675m above ground;
  - Changing the Total Floor Area from 11,615m<sup>2</sup> to 15206.84m<sup>2</sup> approximately;
  - Changing the Plot Ratio from 0.723 to 0.75; and
  - Changing the site coverage from 51.94 % to 39.5%.
- 1.1.4 A new planning application shall be made under Section 16 of the *Town Planning Ordinance* (“TPO”) for the aforementioned major modifications. CK Land Management Company Limited has been commissioned to prepare this Sewerage Impact Assessment (“SIA”) Report for supporting this new planning application.

## 1.2 Site Description

- 1.2.1 The Site is an elongated strip of land bounded by Man Kam To Road to the east and Lo Wu Station Road to the south with a total area of about 16,060m<sup>2</sup> in Sandy Ridge, which is close to the border between Lo Wu Boundary Control Point (“BCP”) and Man Kam To BCP in North District. The Site is currently a vacant land overgrown with weeds and different tree groups. There is a watercourse cutting middle of the site running from the northeast to southeast direction, separating the Site into two halves.
- 1.2.2 The Site location and its environs are shown on **Figure 1-1** which the uses surrounding the Site include:
- To the north, northwest and west: dwellings and residential temporary structures, Sandy Ridge Cemetery and the planned Sandy Ridge Columbarium.
  - To the east and southeast: The pipelines of the Dongjiang Water, Man Kam To Road, temporary structures, Border District Police Headquarter and Police Dog Unit and Force Search Unit Training School.
  - To the south: Sha Ling Playground and Lo Wu Station Road.

## 1.3 Project Description

1.3.1 The Centre will be built upon a site area of about 20,249m<sup>2</sup> with a Gross Floor Area (“GFA”) of about 15,206.84m<sup>2</sup> and a plot ratio of about 0.75, comprising the following major components:

- Main block comprises a cold storage area and ancillary storage, office, FS Facilities, area for corridor, staircase and lift
- A Plant Room and Transformer Room (exempted from GFA)
- Guard House and Management Office

1.3.2 The existing watercourse running through the Site from northeast to southwest direction will be decked over underneath the proposed development.

1.3.3 The indicative layout and sectional plans of the Proposed Development can be referred to the Planning Statement.

## 1.4 Objectives of this Report

1.4.1 The objectives of this SIA report are to:

- Assess the potential sewerage impacts arising from the Centre.
- Recommend the necessary mitigation measures to alleviate the impacts.

## 1.5 Reference Materials

1.5.1 In evaluating the sewage impact arising from the Proposed Development, the following materials have been referred to:

Environmental Protection Department (EPD) publication *Guidelines for Estimating Sewage Flows (GESF) for Sewage Infrastructure Planning* Version 1.0, March 2005.

Hong Kong Planning Standards and Guidelines, PlanD

GeoInfo Map reviewed on 20 April 2022



Figure 1-1: Site Location and its Environs

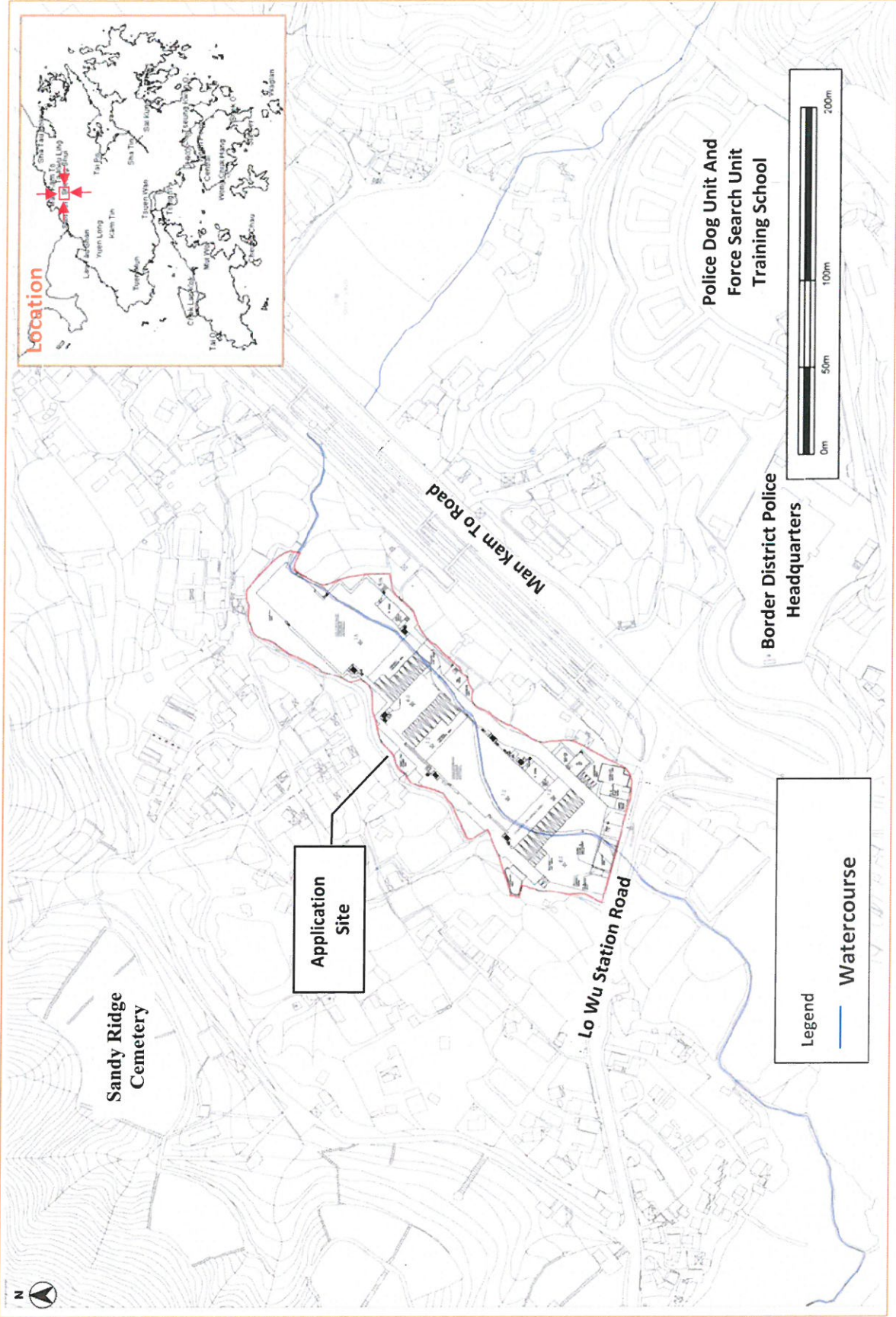

## 2 DESCRIPTION OF EXISTING ENVIRONMENT AND BASELINE CONDITIONS

### 2.1 Site Location

- 2.1.1 The area of the application site is about 16,060 m<sup>2</sup>.
- 2.1.2 As illustrated on **Figure 1-1**, the Site is situated in Sandy Ridge that is an elongated strip land bounded by Man Kam To Road to the east and Lo Wu Station Road to the south. It is adjacent to the Sandy Ridge Cemetery that is bounded by Lo Wo Station Road and Shenzhen River.

### 2.2 Existing Baseline Conditions

- 2.2.1 Upon review of the relevant sewerage and drainage plan available on GeoInfo Map, it was confirmed that there is no existing public sewerage connection available within or in the vicinity of the Site.
- 2.2.2 There are no immediate plans by government to extend the sewerage system to the Site in near future.

### 2.3 Potential Sewerage Impact

- 2.3.1 As mentioned in **Section 1.1**, no selling, slaughtering or cleaning of chilled poultry/meat will be taken place in the Centre. The Centre will be used as a cold storage and distribution centre only and there will be no cooking/kitchen provided for the canteen. Hence, the major source of wastewater will be limited to the sewage from staff, and effluent from floor cleaning of the loading / unloading area and loading platform.
- 2.3.2 As the Site is located within the catchment area of the Deep Bay Water Control Zone ("WCZ"), the "No Net Increase in Pollution Loads Requirement" would be applicable to the Centre. In this regard, all sewage generated from the staff is suggested to be collected by toilets and the septic tank and soakway system for off-site disposal. The wastewater generated from floor cleaning by mopping will be also poured into the toilets and the septic tank and soakway system for off-site disposal.



## 3 SEWERAGE ANALYSIS

### 3.1 Assumptions and Methodology

3.1.1 In order to assess the sewerage impact arising from operation of the Centre, the anticipated sewage generation has been estimated. The numbers of staff on-site are shown in **Table 3-1**.

*Table 3-1: Estimated On-site Populations*

Population Type	Number of people
Workers (3 shifts in total)	60
Office Staff	20
<b>Total</b>	<b>80</b>

3.1.2 The maximum sewage generation from the staff has been estimated based on the number of staff on-site shown in **Table 3-1**. The Average Dry Weather Flows (“ADWF”) of the staff were estimated based on the Unit Flow Factors (“UFFs”) recommended in GESF.

3.1.3 As a conservation approach, the unit flow factor of Commercial Employee has been adopted for the sewage generation from the staff.

3.1.4 The unit rate of total sewage generation per staff is therefore:

$$\text{Unit Flow Factor of Commercial Employee} = 0.08 \text{ m}^3/\text{day}/\text{staff}$$

$$\text{ADWF of sewage from staff} = 0.08 \times 80 = 6.4 \text{ m}^3/\text{day}$$

3.1.5 Daily floor cleaning by mopping will be provided at the loading / unloading area and loading platform. No jet washing will be applied in the Site. The major wastewater source will be condensation and melted ice which can be easily removed by mopping. Only the area of loading and unloading platform and offices are needed to conduct floor cleaning and the area is approximate 1,600m<sup>2</sup>. The purpose of floor cleaning is to remove condensation and water from melted ice, and maintain hygiene during operation. Besides, limited frequency of floor cleaning will be conducted (i.e. 1 time/day) resulting in limited wastewater generated due to the floor cleaning. Therefore, with the consideration of the area need for floor cleaning, source of pollutants, and frequency, the wastewater generated by mopping will be limited to several cubic metres per day only. As the worst case estimation, the volume of wastewater generated via mopping will be not more than 5m<sup>3</sup>/day.

### 3.2 Feasible Options

3.2.1 To reduce the volume of sewage generation from staff, toilets with using less water per flush can be used subject to the detailed design (see an example of a low flush toilet that is available in Hong Kong enclosed in **Appendix A**). In addition to the use of low flush toilet, other measures such as waterless urinals (e.g. using “Desert” waterless cubes, which have been used for some projects in Hong Kong) and water-free hand washing (e.g. using antiseptic gels) may be considered. The use of such water-saving approaches will reduce the sewage generation from the staff.

3.2.2 Taking into consideration the site constraints, provision of toilets for collecting the sewage generated from the staff and the floor cleaning by mopping are the most cost-effective and environmentally sound approaches for the Site respectively.

### 3.3 Results and Discussion

3.3.1 The estimated volume of sewage generated from the staff will be 6.4m<sup>3</sup>/day while the estimated volume of wastewater generated from the floor cleaning will be 5m<sup>3</sup>/day, the total daily wastewater generated from the Centre will be approximately 11.4m<sup>3</sup>/day.

3.3.2 By adopting low flow toilet, the wastewater generated would be further reduced. The sewage generated from the staff and floor cleaning by mopping will be collected by toilets and the septic tank and soakway system for off-site disposal by a licenced collector. Therefore, no adverse sewerage impact due to the Centre is anticipated.



## 4 CONCLUSIONS AND RECOMMENDATIONS

- 4.1.1 Potential sewerage impacts that may arise from the construction and operation of the Centre have been assessed and appropriate mitigation measures are recommended to support the current planning application.
- 4.1.2 The total wastewater generated from the Centre during operation has been estimated at about 11.4m<sup>3</sup>/day. By adopting low flow toilet and the floor cleaning by mopping, the wastewater generated would be further reduced. The sewage generated from the staff and floor cleaning by mopping will be collected by toilets and the septic tank and soakway system for off-site disposal by a licenced collector.
- 4.1.3 In conclusion, no adverse impact due to the Centre is anticipated.

---

Appendix A **CATALOGUE OF LOW FLUSH TOILET**

---



**Jets™ 50M Toilet**  
Product No. TO650PO

Tel. +47 70 03 91 00  
www.jetsgroup.com

Rev 2016-05-09 09:08



Jets™ 50M Toilet is a pedestal pan design. With a focus on both simple elegant design and comfort, this floor mounted toilets contemporary look complements any installation.

**Warranty**

All products of the company are sold and all services of the company are offered subject to Jets Vacuum AS General Sales Conditions detailing warranty and terms and conditions of sale, copies of which will be furnished upon request. The information provided herein is for guidance only; it does not constitute a guarantee of the performance or specification of any individual product or component.

**Disclaimer**

Product color reproduction is as near to actual color as product methods allow. All rights reserved. Information is subject to change without notice. No part of this document may be reproduced in any form by any means without prior written approval.

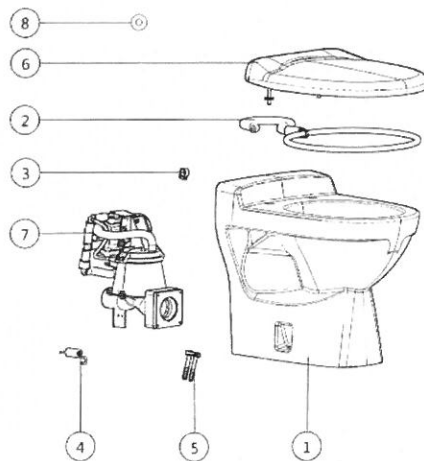

**Technical Data**

Outside Dimensions.....	540 x 365 x 475 mm (LxWxH)
Weight.....	25 kg
General Tolerance.....	Bowl dimensions ±2%
Discharge Valve Outlet.....	Outside diameter Ø 50 mm
Water Connection.....	½" male BSP
Generic Material.....	Porcelain
Outside Dimensions.....	550 x 385 x 475 mm (LxWxH)

**Operating Data**

Flushing Time.....	5 seconds
Discharge Time.....	2 seconds
Water Pressure.....	2-7 bar
Operating Vacuum.....	Recommended 30-55 % Vacuum
Air Consumption.....	Approx. 48 liters at 50% Vacuum
Water Consumption.....	1 liter/s (3 bar)
Temperature Range.....	Minimum 1°C to Maximum 60°C (unless frost protection measures are taken)

Note:..... Values are dependent on valve type.

**Patents and Trademarks**

Jets™, Vacuumator™, Helivac™, VC™, VOD™, CVS™ and Softsound™ are trademarks and/or registered trademarks of Jets. © Copyright 2011, Jets AS.

**Options**

*Optional functions compatible with this product.*

VFD: Vacuum Flush and Discharge  
EFD: Electrical Flush and Discharge  
CFD: Central Flush and Discharge  
LFD: Local Flush and Discharge

**Components**

*Construction Characteristics*

1 Toilet Bowl JETS 50M.....	063600100*
2 Flushing ring.....	069510500*
3 Hose Clip 13-20mm.....	034233401*
4 Spring.....	053531725*
5 Fastening Kit, floor.....	069606301*
6 Seat & Cover.....	See product selection
7 Valve.....	See options listed above
8 Release Mechanism.....	See product selection

\* Component/s available as replacement parts.

**Accessories**

*Construction Characteristics*

Vacuum Breaker Kit.....	034507320
Rubber Elbow w/hose clip.....	034505450
Rubber Sleeve w/hose clip.....	034505550
Rag Hook w/support.....	034102902
Pipe Packet.....	034399300
Cover, Complete.....	063602121
Base plate.....	063608700