

**PLAN**

NOMINAL SIZE (LARGEST OF H1, H2, H3 & H4)	B
300 - 600	150
675 - 900	175

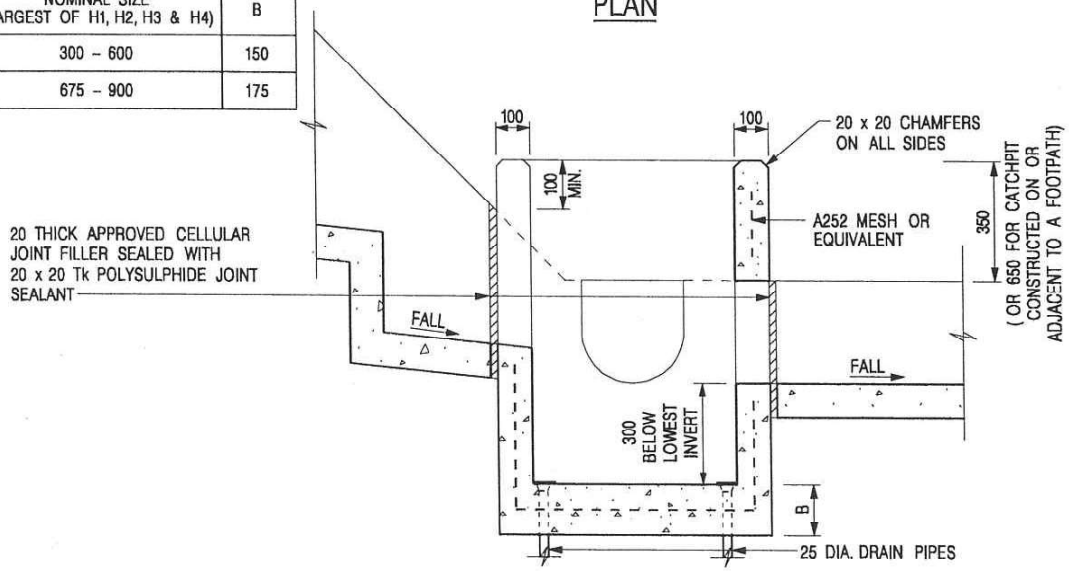

**SECTION A - A**

**NOTES:**

1. ALL DIMENSIONS ARE IN MILLIMETRES.
2. REFER TO SHEET 2 FOR OTHER NOTES.

**CATCHPIT WITH TRAP**  
**(SHEET 1 OF 2)**

-	FORMER DRG. NO. C2406J.	Original Signed	03.2015
REF.	REVISION	SIGNATURE	DATE

**CEDD** **CIVIL ENGINEERING AND DEVELOPMENT DEPARTMENT**

**SCALE** 1 : 20      **DRAWING NO.** C2406 / 1

**DATE** JAN 1991

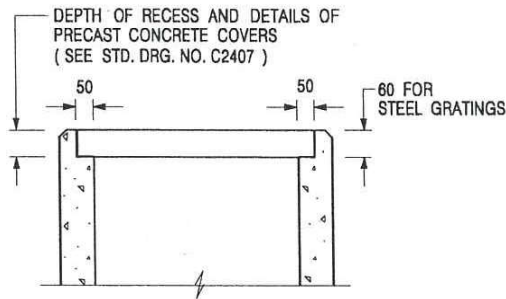

**ALTERNATIVE TOP SECTION  
FOR PRECAST CONCRETE COVERS / GRATINGS**

**NOTES:**

1. ALL DIMENSIONS ARE IN MILLIMETRES.
2. ALL CONCRETE SHALL BE GRADE 20 /20.
3. CONCRETE SURFACE FINISH SHALL BE CLASS U2 OR F2 AS APPROPRIATE.
4. FOR DETAILS OF JOINT, REFER TO STD. DRG. NO. C2413.
5. CONCRETE TO BE COLOURED AS SPECIFIED.
6. UNLESS REQUESTED BY THE MAINTENANCE PARTY AND AS DIRECTED BY THE ENGINEER, CATCHPIT WITH TRAP IS NORMALLY NOT PREFERRED DUE TO PONDING PROBLEM.
7. UPON THE REQUEST FROM MAINTENANCE PARTY, DRAIN PIPES AT CATCHPIT BASE CAN BE USED BUT THIS IS FOR CATCHPITS LOCATED AT SLOPE TOE ONLY AND AS DIRECTED BY THE ENGINEER.
8. FOR CATCHPITS CONSTRUCTED ON OR ADJACENT TO A FOOTPATH, STEEL GRATINGS (SEE DETAIL 'A' ON STD. DRG. NO. C2405 ) OR CONCRETE COVERS (SEE STD. DRG. NO. C2407 ) SHALL BE PROVIDED AS DIRECTED BY THE ENGINEER.
9. IF INSTRUCTED BY THE ENGINEER, HANDRAILING (SEE DETAIL 'G' ON STD. DRG. NO. C2405; EXCEPT ON THE UPSLOPE SIDE ) IN LIEU OF STEEL GRATINGS OR CONCRETE COVERS CAN BE ACCEPTED AS AN ALTERNATIVE SAFETY MEASURE FOR CATCHPITS NOT ON A FOOTPATH NOR ADJACENT TO IT. TOP OF THE HANDRAILING SHALL BE 1 000 mm MIN. MEASURED FROM THE ADJACENT GROUND LEVEL.
10. MINIMUM INTERNAL CATCHPIT WIDTH SHALL BE 1 000 mm FOR CATCHPITS WITH A HEIGHT EXCEEDING 1 000 mm MEASURED FROM THE INVERT LEVEL TO THE ADJACENT GROUND LEVEL. AND, STEP IRONS (SEE DSD STD. DRG. NO. DS1043 ) AT 300 c/c STAGGERED SHALL BE PROVIDED. THICKNESS OF CATCHPIT WALL FOR INSTALLATION OF STEP IRONS SHALL BE INCREASED TO 150 mm.
11. FOR RETROFITTING AN EXISTING CATCHPIT WITH STEEL GRATING, SEE DETAIL 'F' ON STD. DRG. NO. C2405.
12. SUBJECT TO THE APPROVAL OF THE ENGINEER, OTHER MATERIALS CAN ALSO BE USED AS COVERS / GRATINGS.

-	FORMER DRG. NO. C2406J.	Original Signed	03.2015
REF.	REVISION	SIGNATURE	DATE

**CATCHPIT WITH TRAP  
(SHEET 2 OF 2)**



**CIVIL ENGINEERING AND  
DEVELOPMENT DEPARTMENT**

**SCALE 1 : 20**

**DRAWING NO.**

**DATE JAN 1991**

**C2406 /2**

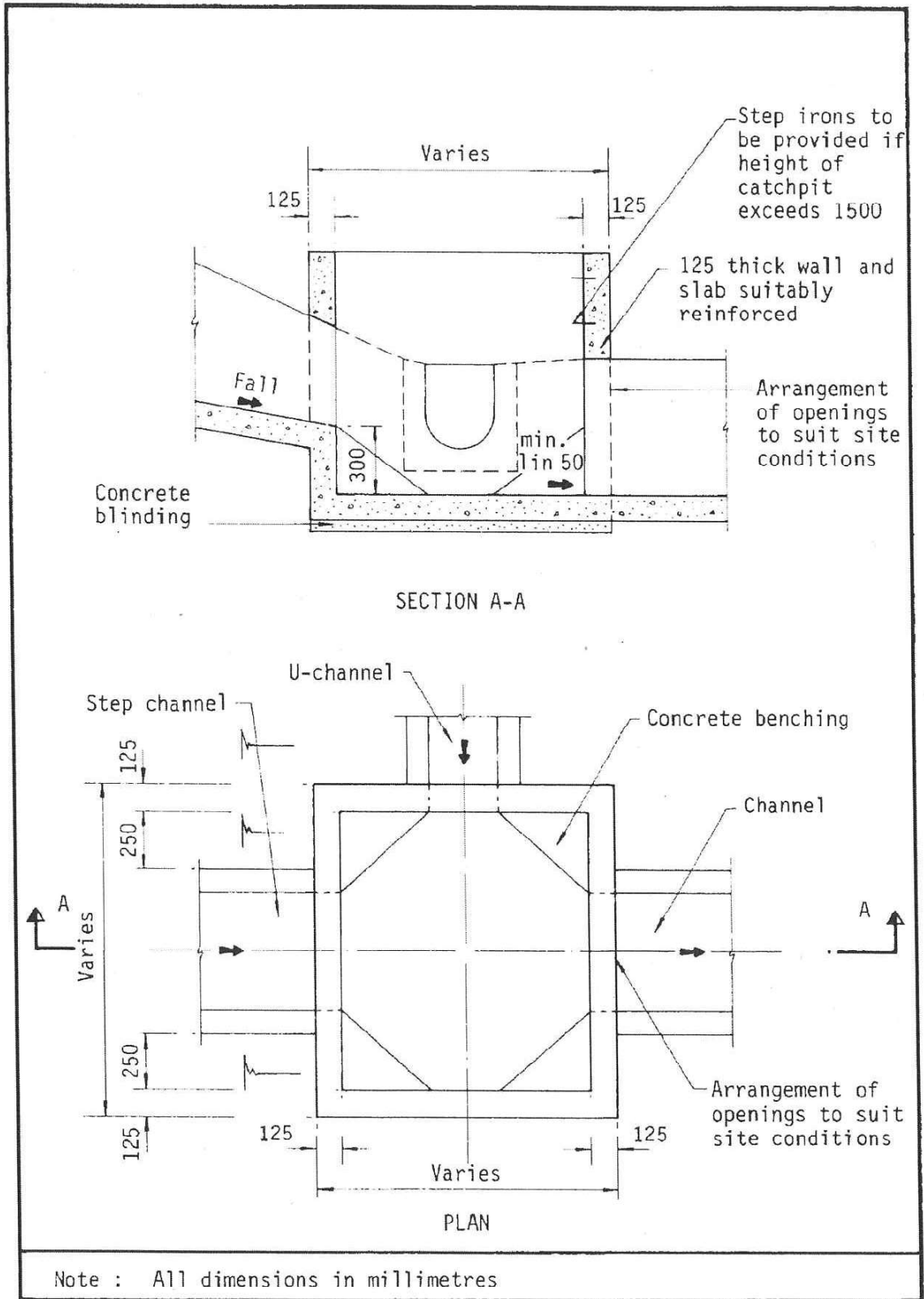
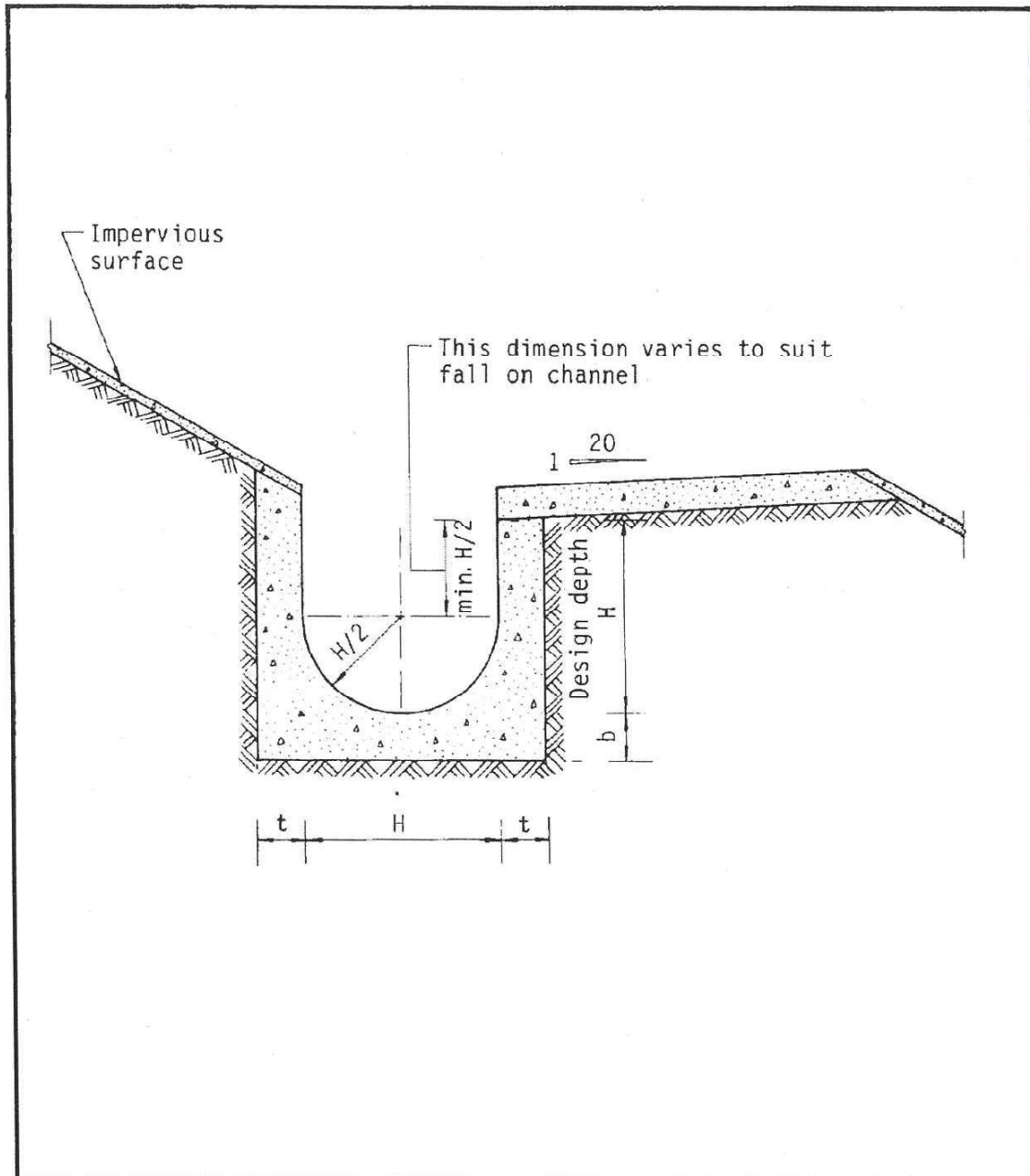

Figure 8.10 - Typical Details of Catchpits



Dimensions of U - channel

Nominal size of channel H (mm)	Thickness t (mm)	Thickness b (mm)
225 to 600	150	150
675 to 1200	175	225

Figure 8.11 - Typical U-channel Details