

Your Ref.: A/NE-SSH/156

Our Ref.: P23055A/TL24405

1 August 2024

The Secretary
Town Planning Board
15/F., North Point Government Offices
333 Java Road, North Point, Hong Kong

By Post and E-mail
tpbpd@pland.gov.hk

Dear Sir,

Submission of Further Information

**Proposed Temporary Private Vehicle Park (Private Cars) for a Period of 3 Years in
“Village Type Development” Zone, Lot Nos. 543 (Part), 544 (Part), 546 (Part),
547 (Part), 548 (Part), 549, 550 (Part), 551 (Part), 552 RP (Part), 553, 603 S.A RP,
605 (Part), 606 RP, 607 (Part), 608 (Part), 609 RP and 610 RP (Part) in D.D. 218
and Adjoining Government Land, Ma Kwu Lam Village, Sai Kung North, New Territories**

We would like to submit further information to respond to the comments from Drainage Services Department dated 23.7.2024.

Yours faithfully,
For and on behalf of
Goldrich Planners & Surveyors Ltd.

Alan Poon p.p.
Francis Lau

Encl.

Further Information (5) for Planning Application Nos. A/NE-SSH/156**Response-to-Comment****Comments from Drainage Services Department received on 23.7.2024**

Contact person: Mr. Justin LAU (Tel.: 2300 1545)

I.	Comment	Response
(c)	Please provide photos showing the existing conditions of the local river sections receiving the runoff from SSH_156.	Please refer to attached photos (viewpoint 5 and viewpoint 6) for the existing conditions of the local river sections receiving the runoff from SSH_156.
(d)	Please indicate the level of existing local river in the connection details in Plan 6.1a.	The level of existing local river in the connection details in Plan 6.1a is indicated in an updated plan (Plan 6.1b)

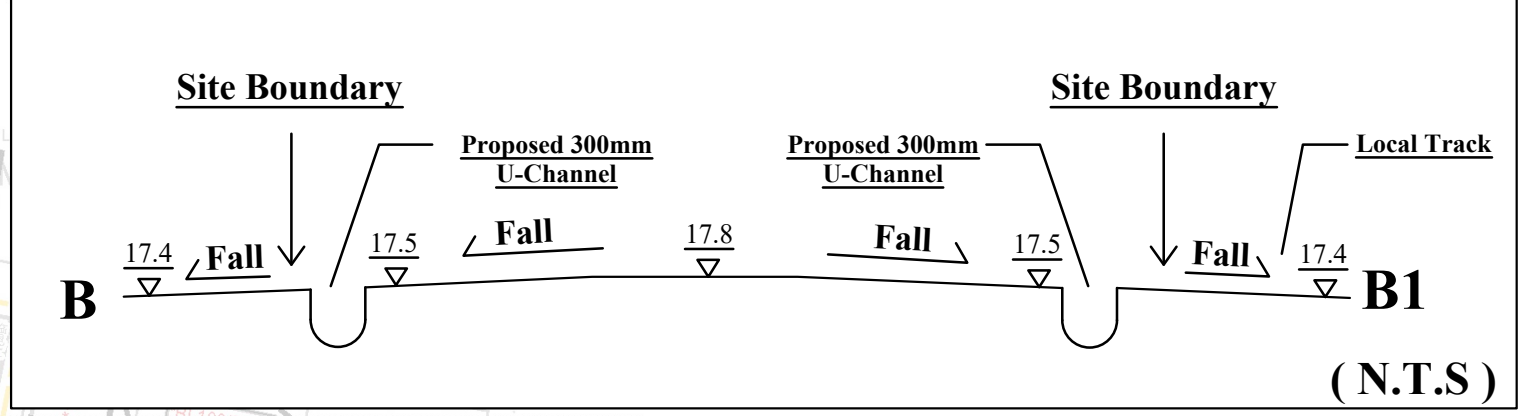
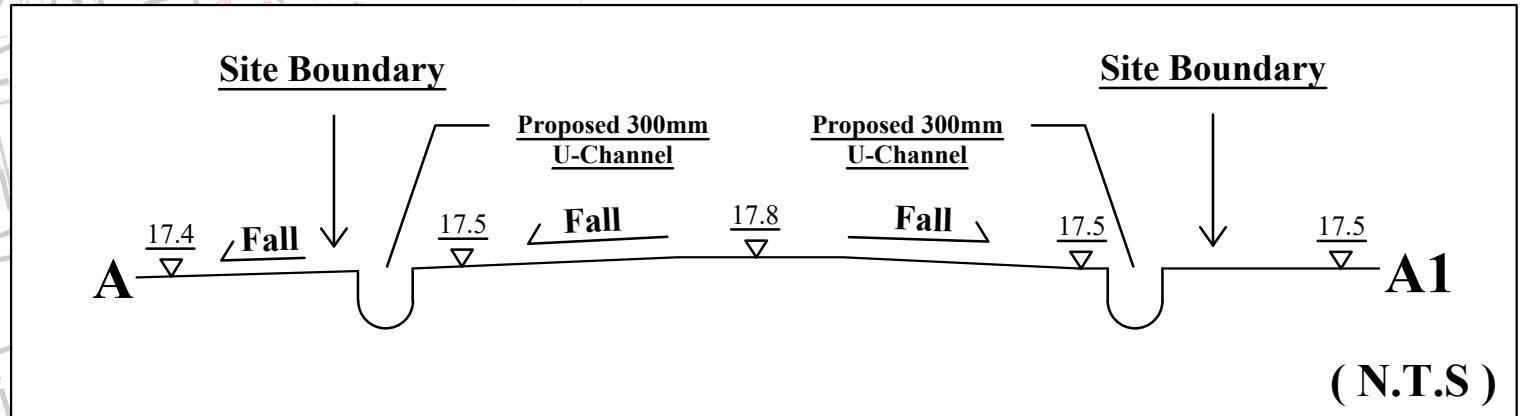
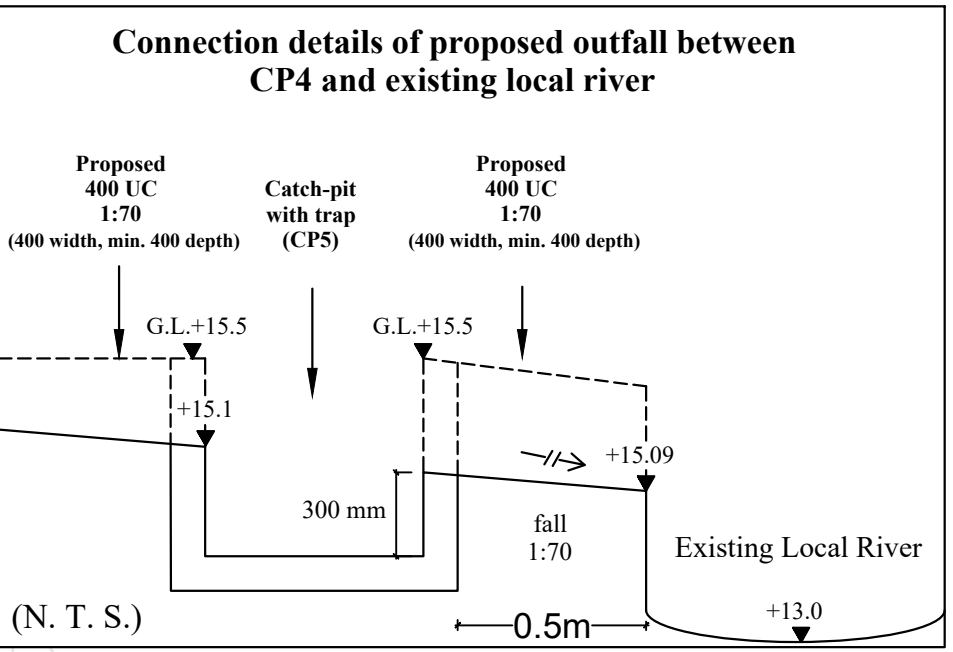
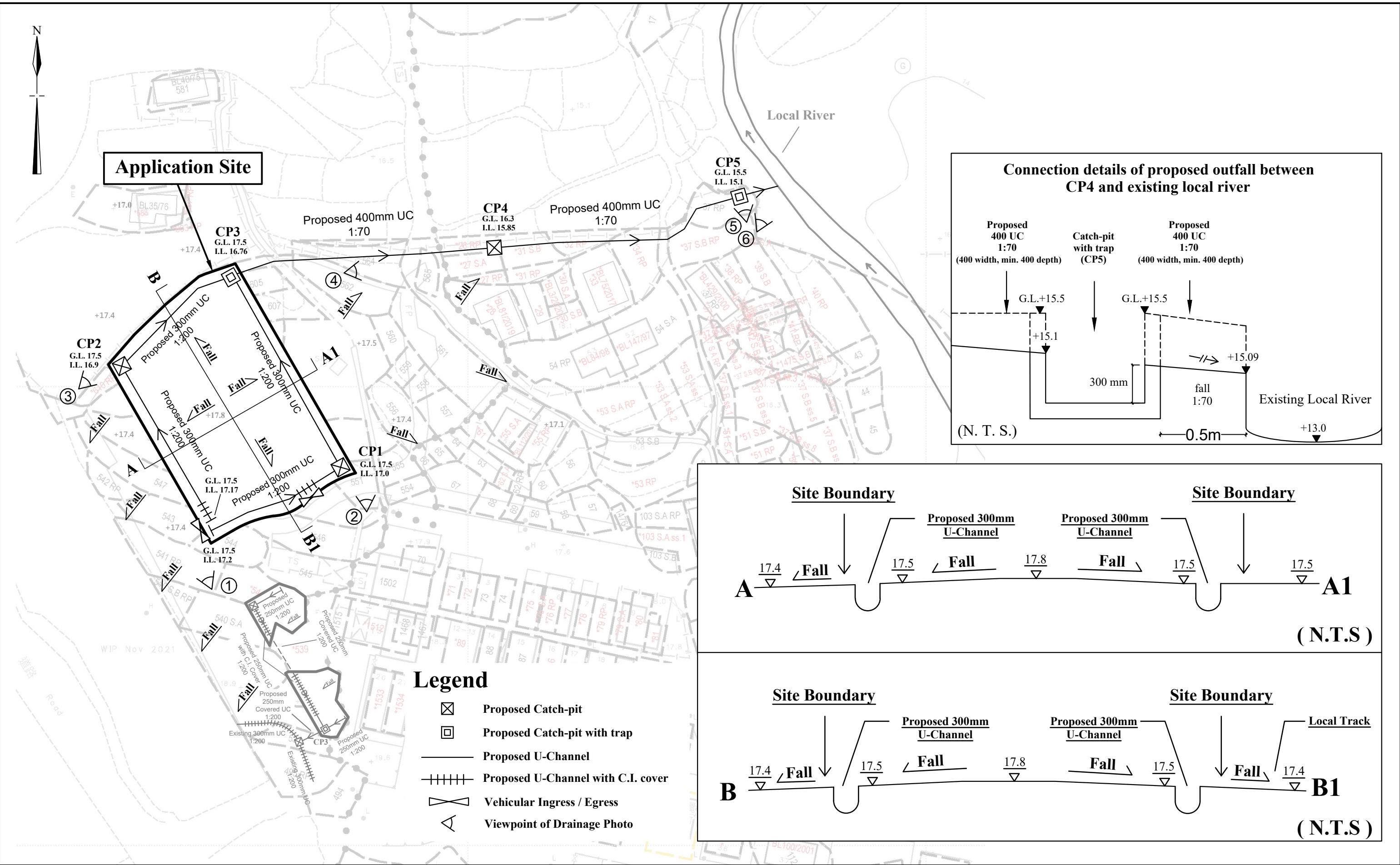

- Legend**
- ☒ Proposed Catch-pit
 - ☐ Proposed Catch-pit with trap
 - Proposed U-Channel
 - ++++ Proposed U-Channel with C.I. cover
 - ⌞ Vehicular Ingress / Egress
 - △ Viewpoint of Drainage Photo

1:750 (A3)

May 2024

Drainage Proposal

Lots 543(part), 544(part), 546(part), 547(part), 548(part), 549,550(part), 551(part), 552 RP(part), 553, 603 SA RP, 605(part), 606 RP, 607(part), 608(part), 609 RP and 610 RP(part) in D.D.218 and adjoining government land Ma Kwu Lam, Sai Kung North, N.T

Goldrich Planners & Surveyors Ltd.

Plan 6.1b
(P 23055A)



Catchment Area A
Concrete Paving : 850m²

Catchment Area C
Concrete Paving : 118m²
Flat grass land : 2,043m²
Total Area: 2,161m²

Catchment Area B
Concrete Paving : 929m²

Existing Planter

Existing Fence Wall

AREA OF CATCHMENT
(N.T.S)

Note:
 According to Technical Note to prepare a Drainage Submission by D.S.D.of November 2001 (p.6),
 450mm U-channel is acceptable for area below 4,000m².

1:500 (A3)
March 2024

<h2>Drainage Proposal</h2> <p>Lots 543(part), 544(part), 546(part), 547(part), 548(part), 549,550(part), 551(part), 552 RP(part), 553, 603 SA RP, 605(part), 606 RP, 607(part), 608(part), 609 RP and 610 RP(part) in D.D.218 and adjoining government land Ma Kwu Lam, Sai Kung North, N.T</p>

<p>Goldrich Planners & Surveyors Ltd.</p> <p>Plan 6.2a (P 23055A)</p>

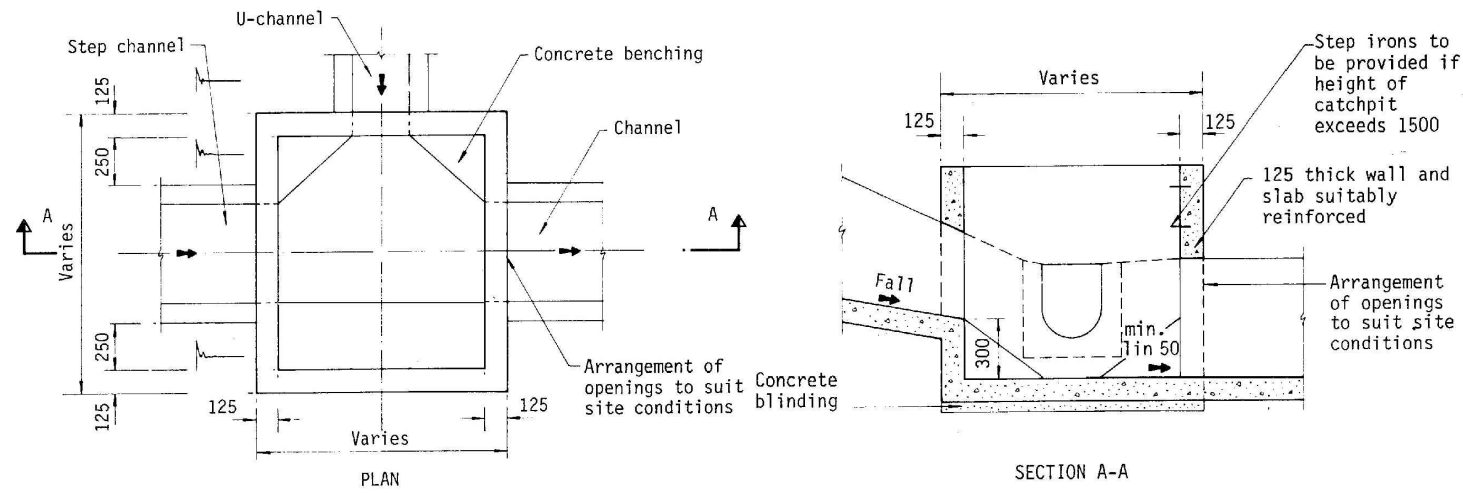

TYPICAL DETAILS OF CATCHPIT

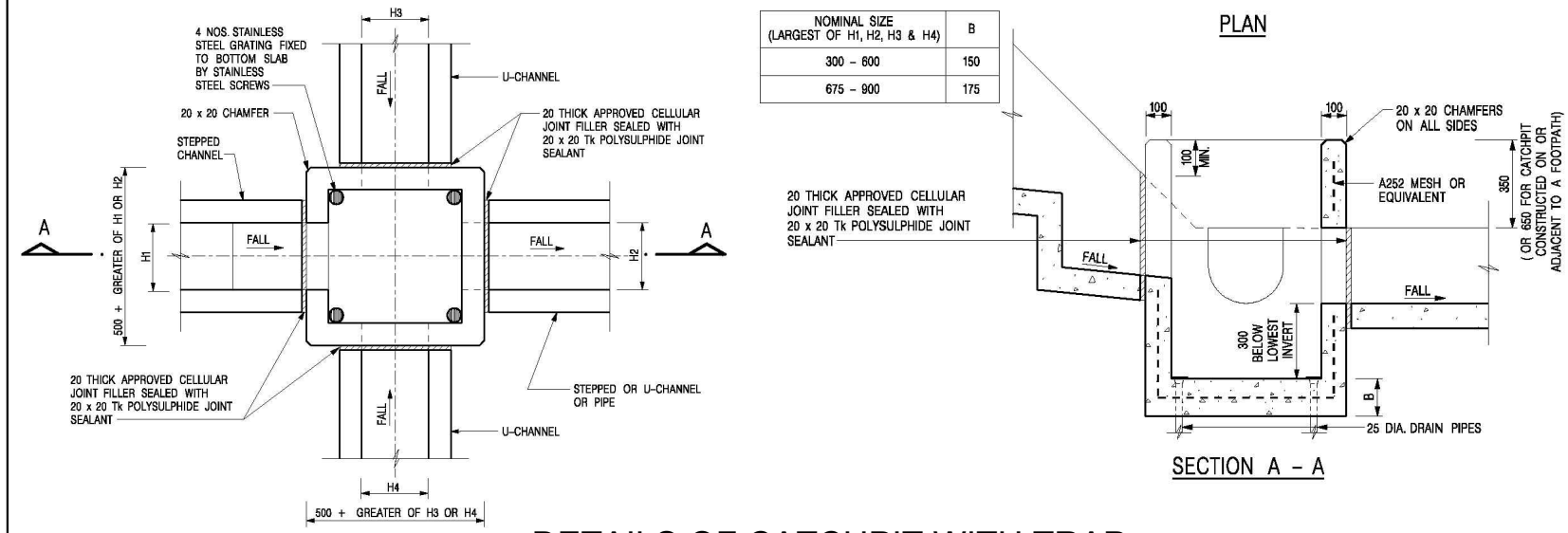

**DETAILS OF CATCHPIT WITH TRAP
(REFER TO CEDD'S STANDARD DWG. C2406/1)**

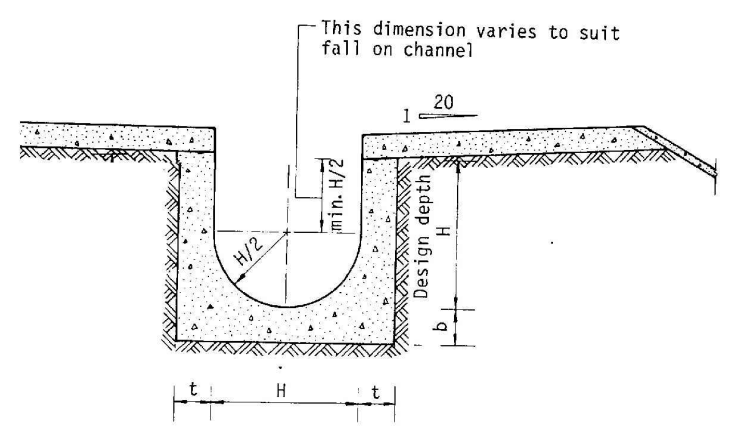

TYPICAL DETAILS OF U CHANNEL

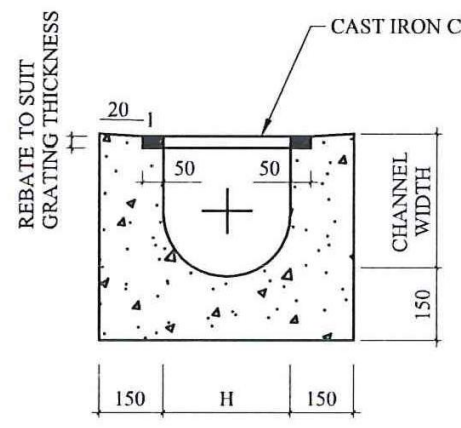

**TYPICAL SECTION OF U-CHANNEL WITH COVER
(N.T.S.)**

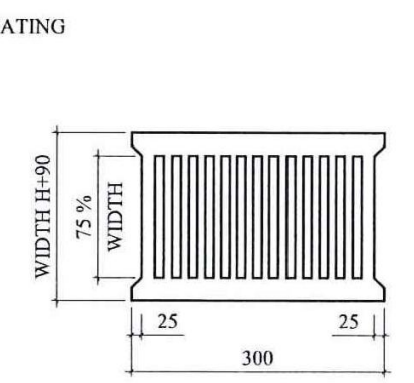

**CAST IRON CRATING
(HEAVY DUTY)**

1:500 (A3)

March 2024

Drainage Proposal

Lots 543(part), 544(part), 546(part), 547(part), 548(part), 549,550(part), 551(part), 552 RP(part), 553, 603 SA RP, 605(part), 606 RP, 607(part), 608(part), 609 RP and 610 RP(part) in D.D.218 and adjoining government land
Ma Kwu Lam, Sai Kung North, N.T

Goldrich Planners & Surveyors Ltd.

Plan 6.3
(P 23055A)

Viewpoint 1



Viewpoint 2

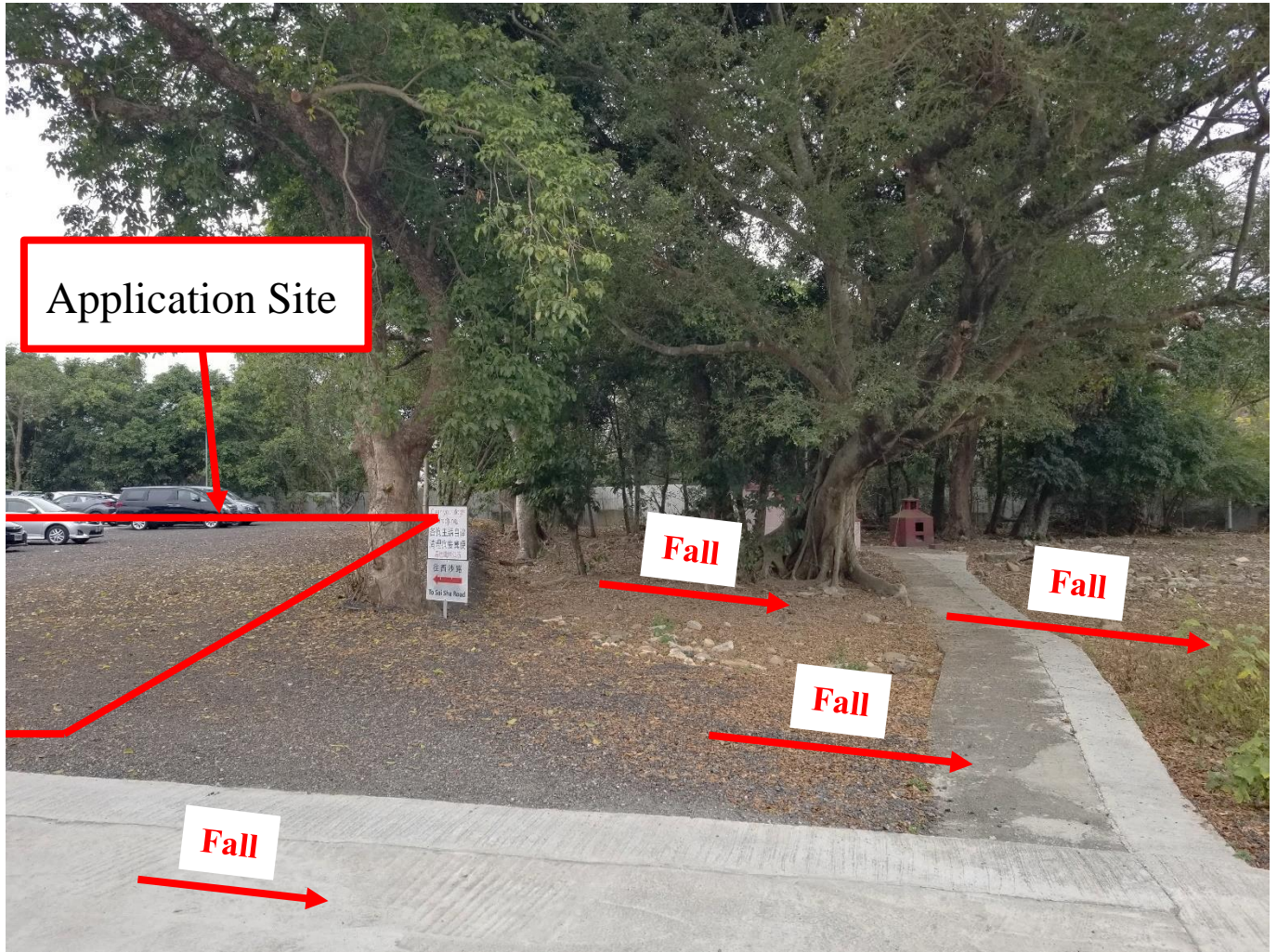

Viewpoint 3



Viewpoint 4



Viewpoint 5

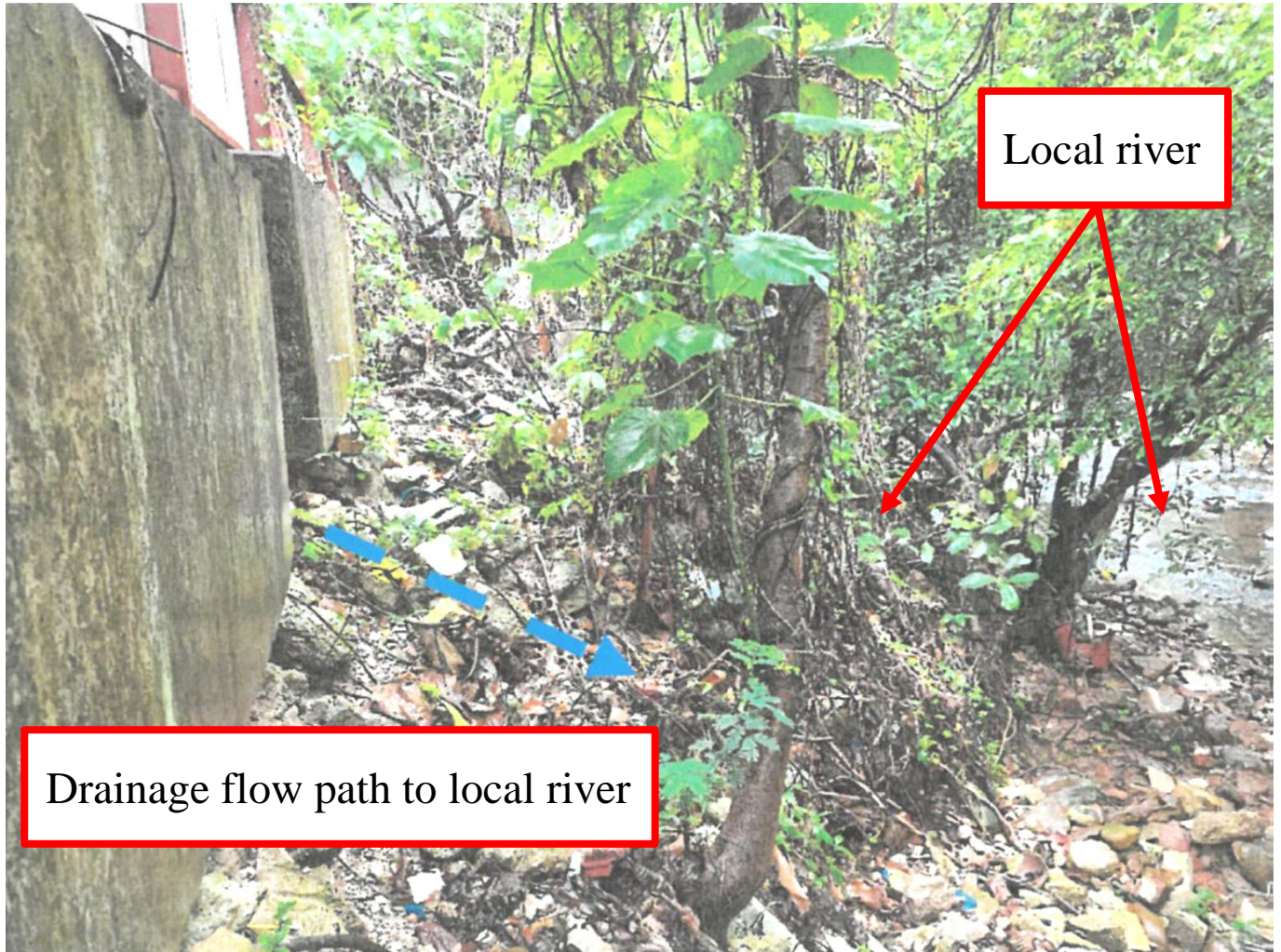

Viewpoint 6



1 For Catchment Area A

Area, A = 850 m²
 Average slope, H = 0.1 m per 100m
 Distance on the line of natural flow, L = 21 m

Time of concentration, $t_c = 0.14465L / (H^{0.2}A^{0.1}) = 0.14465 (21) / (0.1^{0.2} \times 850^{0.1})$
 = 2.5 min

Ref.

SDM 7.5.2 (d)

2 For Proposed U-Channel in catchment area A

	From	To
Ground level (mPD)	17.50	17.50
Invert level (mPD)	17.17	16.76

Width of u-channel, w = 300 mm
 Length of u-channel, $L_c = 81$ m
 Depth of vertical part of u-channel, d = 590 mm
 Gradient of u-channel, $S_f = (17.17 - 16.76) / 81 = 0.005$

Cross-Section Area, $a = 0.5 \pi r^2 + w d = 0.5 \times 3.14 \times 150^2 + 300 \times 590$
 = 0.212 m²

Wetted Perimeter, $p = \pi r + 2 d = 3.14 \times 150 + 2 \times 590$
 = 1.651 m

Hydraulic radius, $R = a / p = 0.129$ m

SDM 8.2.1

3 Use Manning Equation for estimating velocity of stormwater

Take n = 0.016 for concrete lined channels:-
 Allowable velocity, $v = R^{1/6} \times (RS_f)^{1/2} / n = (0.129)^{1/6} \times (0.129 \times 0.005)^{1/2} / 0.016$
 = 1.13 m/s
 Time of flow, $t_f = 1.2$ min

SDM Table 13

SDM Table 12

4 Use "Rational Method" for calculation of design flow

Design intensity, $i = a / (t_o + t_f + b)^c$
 = $505.5 / (2.5 + 1.2 + 3.29)^{0.35}$ for return period T = 50 years
 = 254

SDM 4.3.2

SDM Table 3(a)

Type of surface	Runoff Coefficient C	Catchment Area A (m ²)	C x A
Flat Glassland (heavy soil)	0.25	0.0	0.0
Concrete Paving	0.95	850.0	807.5
			SUM = 807.5

SDM 7.5.2 (b)

Upstream flow, $Q_u = 0$ m³/s

Design flow, $Q_d = 0.278i \Sigma C_j A_j + Q_u$ where A_j is in km²
 = $0.278 \times 254 \times 807.5 / 1000000 + 0$
 = 0.057 m³/s

SDM 7.5.2 (a)

Allowable flow, $Q_a = a \times v$
 = 0.212×1.13
 = 0.239 m³/s

> Q_d (O.K.)

Reference was made to Stormwater Drainage Manual (SDM) by DSD

Scale: NA

Drainage Calculation

Goldrich Planners &
 Surveyors Ltd.

June 2024

Lots 543(part), 544(part), 546(part), 547(part), 548(part), 549,550(part), 551(part), 552 RP(part), 553, 603 SA RP, 605(part), 606 RP, 607(part), 608(part), 609 RP and 610 RP(part) in D.D.218 and adjoining government land, Ma Kwu Lam, Sai Kung North, N.T

Page 1
 (P23055A)

1 For Catchment Area B and C

Area, A = 929 m²
 Average slope, H = 0.1 m per 100m
 Distance on the line of natural flow, L = 21 m

Time of concentration, $t_o = 0.14465L / (H^{0.2}A^{0.1}) = 0.14465 (21) / (0.1^{0.2} \times 929^{0.1})$
 = 2.4 min

SDM 7.5.2 (d)

2 For Proposed U-Channel in catchment area B and C

	From	To
Ground level (mPD)	17.50	17.50
Invert level (mPD)	17.20	16.76

Width of u-channel, w = 300 mm
 Length of u-channel, L_c = 88.2 m
 Depth of vertical part of u-channel, d = 591 mm
 Gradient of u-channel, S_f = (2-16.759)/88.2 = 0.005

Cross-Section Area, a = $0.5 \pi r^2 + w d = 0.5 \times 3.14 \times 150^2 + 300 \times 591$
 = 0.213 m²

Wetted Perimeter, p = $\pi r + 2 d = 3.14 \times 150 + 2 \times 591$
 = 1.653 m

Hydraulic radius, R = a / p
 = 0.129 m

SDM 8.2.1

3 Use Manning Equation for estimating velocity of stormwater

Take n = 0.016 for concrete lined channels:-
 Allowable velocity, v = $R^{1/6} \times (RS_f)^{1/2} / n = (0.129)^{1/6} \times (0.129 \times 0.005)^{1/2} / 0.016$
 = 1.13 m/s
 Time of flow, t_f = 1.3 min

SDM Table 13
 SDM Table 12

4 Use "Rational Method" for calculation of design flow

Design intensity, i = a / (t_o + t_f + b)^c
 = 505.5 / (2.4+1.3+3.29)^{0.35} for return period T = 50 years
 = 253

SDM 4.3.2
 SDM Table 3(a)

Type of surface	Runoff Coefficient C	Catchment Area A (m ²)	C x A
Flat Glassland (heavy soil)	0.25	0.0	0.0
Concrete Paving	0.95	929.0	882.6
SUM =			882.6

SDM 7.5.2 (b)

Upstream flow, Q_u = 0 m³/s

Design flow, Q_d = 0.278i Σ C_fA_j + Q_u where A_j is in km²
 = 0.278 x 253 x 882.55 / 1000000 + 0
 = 0.062 m³/s

SDM 7.5.2 (a)

Allowable flow, Q_a = a x v
 = 0.213 x 1.13
 = 0.239 m³/s

> Q_d (O.K.)

Reference was made to Stormwater Drainage Manual (SDM) by DSD

Scale: NA

Drainage Calculation

Goldrich Planners &
 Surveyors Ltd.

June 2024

Lots 543(part), 544(part), 546(part), 547(part), 548(part), 549,550(part), 551(part), 552
 RP(part), 553, 603 SA RP, 605(part), 606 RP, 607(part), 608(part), 609 RP and 610 RP(part)
 in D.D.218 and adjoining government land, Ma Kwu Lam, Sai Kung North, N.T

Page 2
 (P23055A)

1 For Catchment Area D

Area, A = 2161 m²
 Average slope, H = 2.08 m per 100m
 Distance on the line of natural flow, L = 24 m

Time of concentration, $t_c = 0.14465L / (H^{0.2}A^{0.1}) = 0.14465 (24) / (2.08^{0.2} \times 2161^{0.1})$
 = 1.4 min

Ref.

SDM 7.5.2 (d)

2 For Proposed U-Channel in catchment area D

	From	To
Ground level (mPD)	17.50	15.50
Invert level (mPD)	16.76	15.10

Width of u-channel, w = 400 mm
 Length of u-channel, L_c = 116.5 m
 Depth of vertical part of u-channel, d = 200 mm
 Gradient of u-channel, S_f = (16.76-15.1)/116.5 = 0.014

Cross-Section Area, a = $0.5 \pi r^2 + w d = 0.5 \times 3.14 \times 200^2 + 400 \times 200$
 = 0.143 m²
 Wetted Perimeter, p = $\pi r + 2 d = 3.14 \times 200 + 2 \times 200$
 = 1.028 m
 Hydraulic radius, R = a / p
 = 0.139 m

SDM 8.2.1

3 Use Manning Equation for estimating velocity of stormwater

Take n = 0.016 for concrete lined channels:-
 Allowable velocity, v = $R^{1/6} \times (RS_f)^{1/2} / n = (0.139)^{1/6} \times (0.139 \times 0.014)^{1/2} / 0.016$
 = 2.00 m/s
 Time of flow, t_f = 1.0 min

SDM Table 13
SDM Table 12

4 Use "Rational Method" for calculation of design flow

Design intensity, i = $a / (t_o + t_f + b)^c$
 = $505.5 / (1.4 + 1 + 3.29)^{0.355}$ for return period T = 50 years
 = 273

SDM 4.3.2
SDM Table 3(a)

Type of surface	Runoff Coefficient C	Catchment Area A (m ²)	C x A
Flat Glassland (heavy soil)	0.25	2043.0	510.8
Concrete Paving	0.95	118.0	112.1
SUM =			622.9

SDM 7.5.2 (b)

Upstream flow, Q_u = 0.119 m³/s

Design flow, Q_d = $0.278i \sum C_j A_j + Q_u$ where A_j is in km²
 = $0.278 \times 273 \times 622.85 / 1000000 + 0.119$
 = 0.166 m³/s

SDM 7.5.2 (a)

Allowable flow, Q_a = a x v
 = 0.143 x 2
 = 0.286 m³/s
 > Q_d (O.K.)

Reference was made to Stormwater Drainage Manual (SDM) by DSD

Scale: NA

Drainage Calculation

Goldrich Planners & Surveyors Ltd.

June 2024

Lots 543(part), 544(part), 546(part), 547(part), 548(part), 549,550(part), 551(part), 552 RP(part), 553, 603 SA RP, 605(part), 606 RP, 607(part), 608(part), 609 RP and 610 RP(part) in D.D.218 and adjoining government land, Ma Kwu Lam, Sai Kung North, N.T

Page 3
(P23055A)

1 For Channel Section S1

Area, A = 0 m²
 Average slope, H = 0.1 m per 100m
 Distance on the line of natural flow, L = 0 m

Time of concentration, $t_c = 0.14465L / (H^{0.2}A^{0.1}) = 0.14465 (0) / (0.1^{0.2} \cdot 0^{0.1})$
 = 0.0 min

Ref.

SDM 7.5.2 (d)

2 For Proposed U-Channel Section S1

	From	To
Ground level (mPD)	15.50	15.50
Invert level (mPD)	15.10	15.09

Width of u-channel, w = 400 mm
 Length of u-channel, $L_c = 0.5$ m
 Depth of vertical part of u-channel, d = 207 mm
 Gradient of u-channel, $S_f = (15.1 - 15.093) / 0.5 = 0.014$

Cross-Section Area, $a = 0.5 \pi r^2 + w d = 0.5 \times 3.14 \times 200^2 + 400 \times 207$
 = 0.146 m²
 Wetted Perimeter, $p = \pi r + 2 d = 3.14 \times 200 + 2 \times 207$
 = 1.042 m
 Hydraulic radius, $R = a / p = 0.140$ m

SDM 8.2.1

3 Use Manning Equation for estimating velocity of stormwater

Take n = 0.016 for concrete lined channels:-
 Allowable velocity, $v = R^{1/6} \times (RS_f)^{1/2} / n = (0.14)^{1/6} \times (0.14 \times 0.014)^{1/2} / 0.016$
 = 1.99 m/s
 Time of flow, $t_f = 0.00$ min

SDM Table 13
 SDM Table 12

4 Use "Rational Method" for calculation of design flow

Design intensity, $i = a / (t_c + t_f + b)^c$
 = $505.5 / (0 + 0 + 3.29)^{0.355}$ for return period T = 50 years
 = 331

SDM 4.3.2
 SDM Table 3(a)

Type of surface	Runoff Coefficient C	Catchment Area A (m ²)	C x A
Flat Glassland (heavy soil)	0.25	0.0	0.0
Concrete Paving	0.95	0.0	0.0
SUM =			0.0

SDM 7.5.2 (b)

Upstream flow, $Q_u = 0.166$ m³/s

Design flow, $Q_d = 0.278i \sum C_j A_j + Q_u$ where A_j is in km²
 = $0.278 \times 331 \times 0 / 1000000 + 0.166$
 = 0.166 m³/s

SDM 7.5.2 (a)

Allowable flow, $Q_a = a \times v$
 = 0.146×1.99
 = 0.290 m³/s

> Q_d (O.K.)

Reference was made to Stormwater Drainage Manual (SDM) by DSD