

Ping Che
 坪峯
 NTE/N/PinChe-09

PROJECT NO.	40782
DESIGNED	SKL
DRAWN	CLL
CHECKED	SLN
DATE	OCT 2021
SCALE	1:400

PROJECT TITLE	
DRAWING TITLE	PROPOSED LAYOUT PLAN

DRAWING NO.	FIGURE R1
REV.	.
LLA 顧問有限公司 Consultancy Limited	

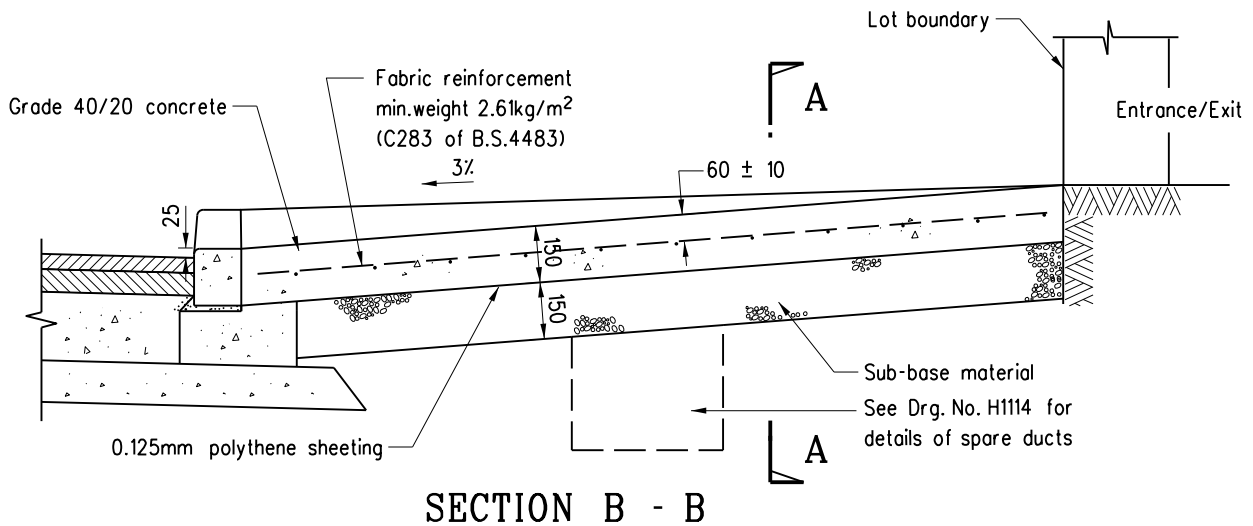
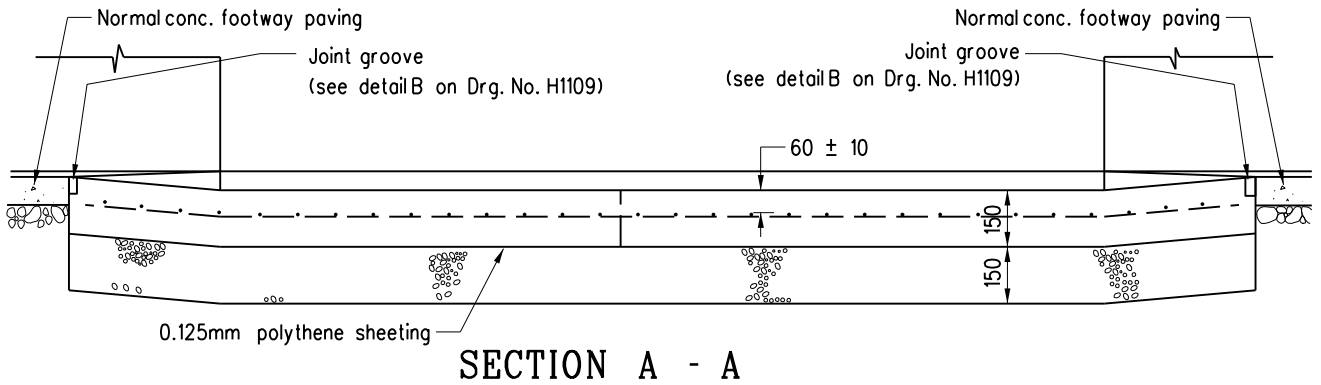
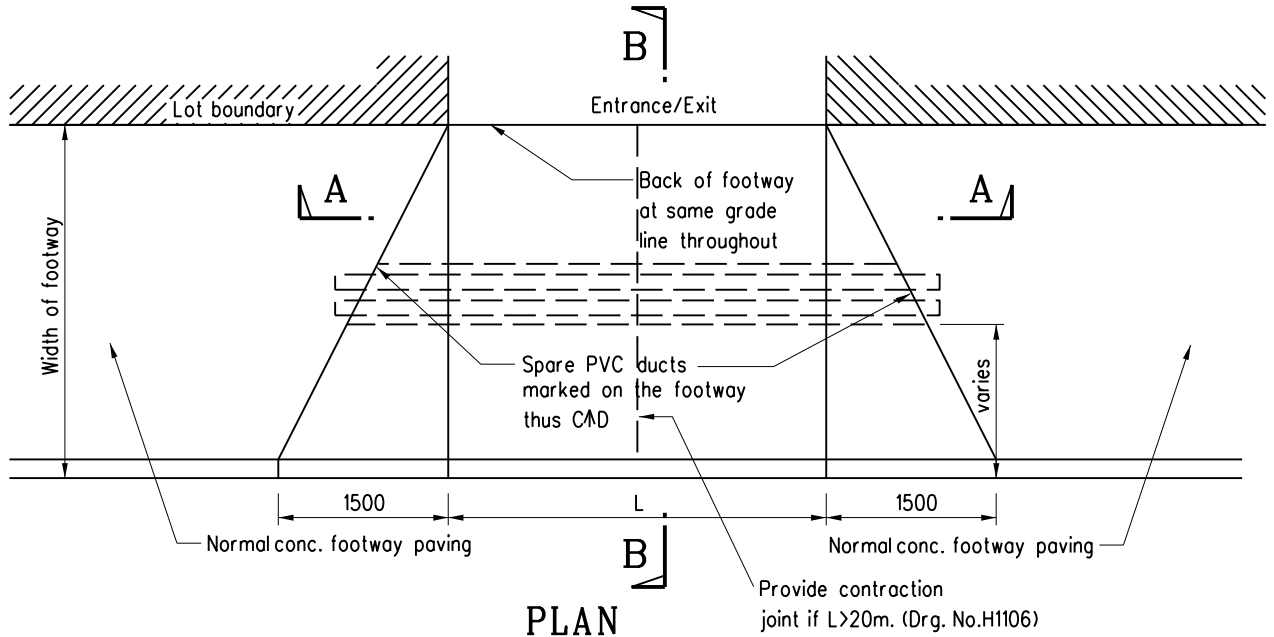

Note:

1. All dimensions are in millimetres.

REF.	REVISION	SIGNATURE	DATE
C	General revision	Original signed	Oct 19
B	Joint groove details revised	-	Nov 96
A	Grade of concrete revised	-	Sept 96
	Former Drg. No. H1011A with general revision	-	June 94

**TYPICAL DETAILS
OF RUN-IN
(SHEET 1 OF 2)**

HIGHWAYS DEPARTMENT

REFERENCE

DRAWING No.

CAD

SCALE

1:20

H 1113C

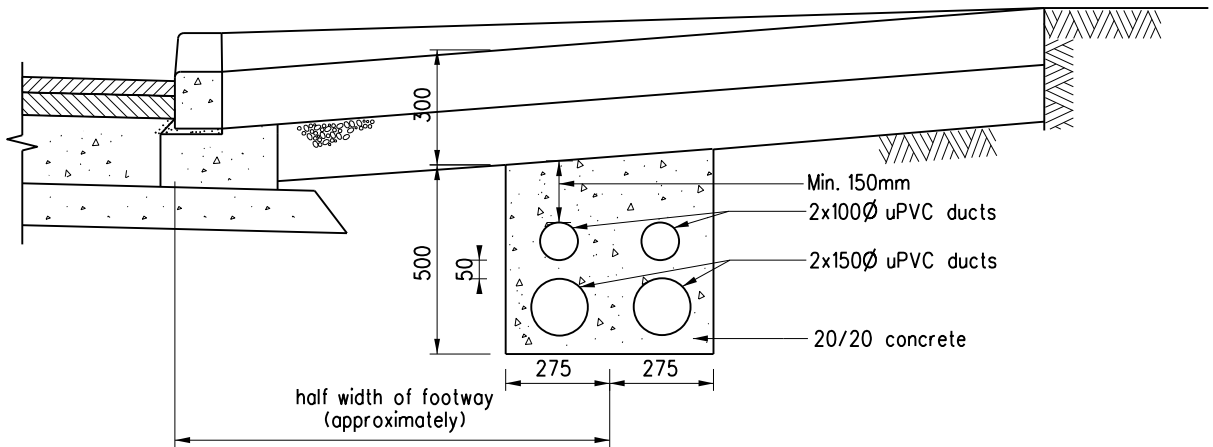

OPTION A

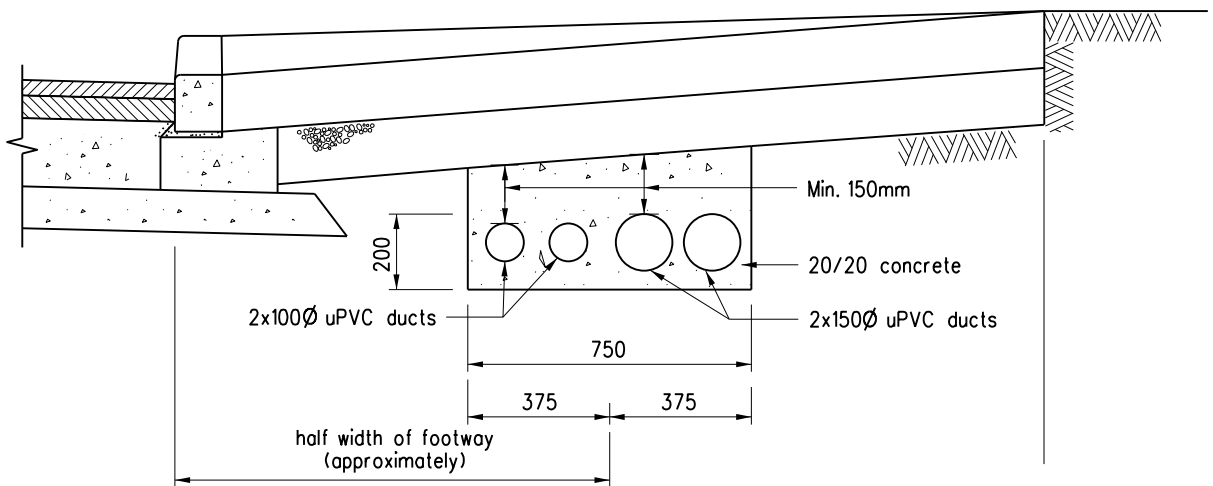

OPTION B

Notes:

1. 100 diameter ducts are provided for cables of ATC or CCTV.
150 diameter ducts are provided for power cables.
2. The choice of option depends on the site situations (e.g. width of footway, existing underground utilities).
3. Position of both ends of the duct bank to be marked on footway thus CAD.

B	General revision	Original signed	Oct 19
A	Concrete cover revised		Sep 96
	Former Drg. No. H1011A with general revision		Jun 94
REF.	REVISION	SIGNATURE	DATE

TYPICAL DETAILS
OF RUN-IN
(SHEET 2 OF 2)

HIGHWAYS DEPARTMENT

REFERENCE

DRAWING No.

CAD

SCALE

1:20

H 1114B

F.S. NOTES:

1. GENERAL

- 1.1 FIRE SERVICE INSTALLATIONS SHALL BE PROVIDED IN ACCORDANCE WITH THE CODES OF PRACTICE FOR MINIMUM FIRE SERVICE INSTALLATIONS AND EQUIPMENT AND INSPECTION, TESTING AND MAINTENANCE OF INSTALLATIONS AND EQUIPMENT 2012 (COP 2012), FSD CIRCULAR LETTERS AND THE HONG KONG WATERWORKS STANDARD REQUIREMENTS.
- 1.2 ALL TUBES AND FITTINGS SHALL BE G.M.S. TO BS1387 MEDIUM GRADE WHERE PIPEWORK UP TO ø150mm.
- 1.3 ALL TUBES AND FITTINGS SHALL BE DUCTILE IRON TO BS EN545 K12 WHERE PIPEWORK ABOVE ø150mm.
- 1.4 ALL DRAIN PIPES SHALL BE DISCHARGED TO A CONSPICUOUS POSITION WITHOUT THE POSSIBILITY OF BEING SUBMERGED.
- 1.5 ALL PUDDLE FLANGES SHALL BE MADE OF DUCTILE IRON
- 1.6 THE AGGREGATE AREA OF OPENABLE WINDOWS NOT LESS THAN 6.25% OF THE FLOOR AREA OF THE STRUCTURE
- 1.7 VENTILATION/AIR CONDITIONING SYSTEM NOT TO BE PROVIDED.

2. HOSE REEL SYSTEM

- 2.1 NEW FIRE HOSE REEL SHALL BE PROVIDED AS INDICATED ON PLAN TO ENSURE THAT EVERY PART OF THE BUILDING CAN BE REACHED BY A LENGTH OF NOT MORE THAN 30m HOSE REEL TUBING.
- 2.2 THE WATER SUPPLY FOR HOSE REEL SYSTEM WILL BE FED FROM A NEW 2m³ F.S. FIBREGLASS WATER TANK VIA TWO HOSE REEL PUMPS (DUTY/STANDBY) LOCATED INSIDE FS PUMP ROOM AT EXTERNAL AREA.
- 2.3 HOSE REEL PUMPS SHALL BE STARTED BY ACTUATION OF ANY BREAKGLASS UNIT FITTED ASIDE EACH HOSE REEL SETS
- 2.4 ALL FIRE HOSE REEL OUTLETS SHOULD BE HOUSED IN GLASS FRONTED CABINET SECURED UNDER LOCK & KEY.
- 2.5 ALL FIRE HOSE REEL SHOULD BE PROVIDED WITH FSD APPROVED TYPE INSTRUCTION PLATE & WSD WARNING PLATE
- 2.6 SECONDARY ELECTRICITY SUPPLY DIRECTLY TEE OFF BEFORE CLP'S INCOMING MAIN SWITCH SHALL BE PROVIDED FOR THE FH/HR PUMPS.

3. AUTOMATIC SPRINKLER SYSTEM

- 3.1 NEW AUTOMATIC SPRINKLER SYSTEM SHALL BE PROVIDED AND INSTALLED IN ACCORDANCE WITH LPC RULES FOR AUTOMATIC SPRINKLER INSTALLATIONS INCORPORATING BS EN 12845: 2015 (INCLUDING TECHNICAL BULLETINS, NOTES, COMMENTAR AND RECOMMENDATIONS) AND FSD CIRCULAR LETTER NO. 5/2020. THE CLASSIFICATION OF THE OCCUPANCIES WILL BE ORDINARY HAZARD GROUP III.
- 3.2 ONE NEW 135m³ SPRINKLER WATER TANK WILL BE PROVIDED AS INDICATED ON PLAN. THE TOWN MAIN WATER SUPPLY WILL BE FED FROM SINGLE END.
- 3.3 TWO NEW SPRINKLER PUMPS (DUTY/STANDBY) AND ONE JOCKEY PUMP SHALL BE PROVIDED IN FS PUMP ROOM LOCATED AT EXTERNAL AREA.
- 3.4 NEW SPRINKLER CONTROL VALVE SET AND SPRINKLER INLET SHALL BE PROVIDED AS INDICATED ON PLAN.
- 3.5 A TEST VALVE SHALL BE PROVIDED FOR EACH ZONE OF SPRINKLER PIPE. THIS VALVE SHALL BE AT A CONSPICUOUS POSITION THAT WATER CAN BE DRAINED AWAY EASILY.
- 3.6 ALL SUBSIDIARY STOP VALVES TO BE ELECTRIC MONITORING TYPE.
- 3.7 ALL ELECTRIC TYPE VALVES SHOULD GIVE VISUAL SIGNALS TO FIRE SERVICE MAIN SUPERVISORY CONTROL PANEL TO INDICATE THE STATUS (OPEN/CLOSE) OF THE VALVES.
- 3.8 SECONDARY ELECTRICITY SUPPLY DIRECTLY TEE OFF BEFORE CLP'S INCOMING MAIN SWITCH SHALL BE PROVIDED FOR THE SPRINKLER PUMPS.
- 3.9 THE SPRINKLER SYSTEM DESIGN IS BASED ON THE FOLLOWINGS:
 HAZARD CLASS : ORDINARY HAZARD GROUP III
 TYPE OF STORAGE : POST-PALLET (ST2)
 STORAGE CATEGORY : CATEGORY I
 MAXIMUM STORAGE HEIGHT : 3.5m
 SPRINKLER PROTECTION : CEILING PROTECTION ONLY
 MAXIMUM STORAGE AREA : 50m²

4. FIRE ALARM SYSTEM

- 4.1 NEW FIRE ALARM SYSTEM SHALL BE PROVIDED IN ACCORDANCE WITH BS 5839 PART 1: 2017 AND FSD CIRCULAR LETTERS 6/2021.
- 4.2 NEW BREAKGLASS UNITS AND FIRE ALARM BELLS SHALL BE PROVIDED AT ALL NEW FIRE HOSE REEL POINTS. THE FIRE ALARM INTALLATION WILL BE INTEGRATED WITH THE HOSE REEL SYSTEM.

5. EMERGENCY LIGHTING

- 5.1 EMERGENCY LIGHTING SHALL BE PROVIDED IN ACCORDANCE WITH 'BS 5266-PART 1 :2016 AND BS EN 1838 :2013', AND FSD CIRCULAR LETTER 4/2021, COVERING ALL AREA. EMERGENCY LIGHTINGS SHALL BE BACKED UP BY BUILT-IN BATTERY AND CAPABLE OF MAINTAINING FUNCTION OF NOT LESS THAN 2 HOURS IN CASE OF POWER FAILURE

6. EXIT SIGN

- 6.1 ALL EXIT SIGNS/DIRECTIONAL EXIT SIGNS SHALL BE PROVIDED IN ACCORDANCE WITH 'BS 5266-PART 1 :2011 AND FSD CIRCULAR LETTER NO. 5/2008, FOR THE BUILDING. EXIT SIGNS/DIRECTIONAL EXIT SIGNS SHALL BE BACKED UP BY BUILT-IN BATTERY AND CAPABLE OF MAINTAINING FUNCTION OF NOT LESS THAN 2 HOURS IN CASE OF POWER FAILURE.

7. PORTABLE APPLIANCES

- 7.1 PORTABLE HAND OPERATED APPLIANCES SHALL BE PROVIDED AS INDICATED ON PLAN.

LEGEND

HOSE REEL	EMERGENCY LIGHT	5KG CO2 FIRE EXTINGUISHER	5KG DRY POWDER FIRE EXTINGUISHER
BREAK GLASS UNIT	EXIT SIGN	SPRINKLER CONTROL VALVE SET	SPRINKLER HEAD (ON PLAN)
FIRE ALARM BELL	SUBSIDIARY VALVE / FLOW SWITCH	SPRINKLER INLET	PUMP SET

Structure 1 Openable Windows Calculation

Area of Structure 1 = 800 sq.m.
 Area of High Bay Window (H.B.W.) = 2.0m(H) x 26m(total length) = 52 sq.m.
 Total openable window area = 52 sq.m.
 = 6.5% of floor area

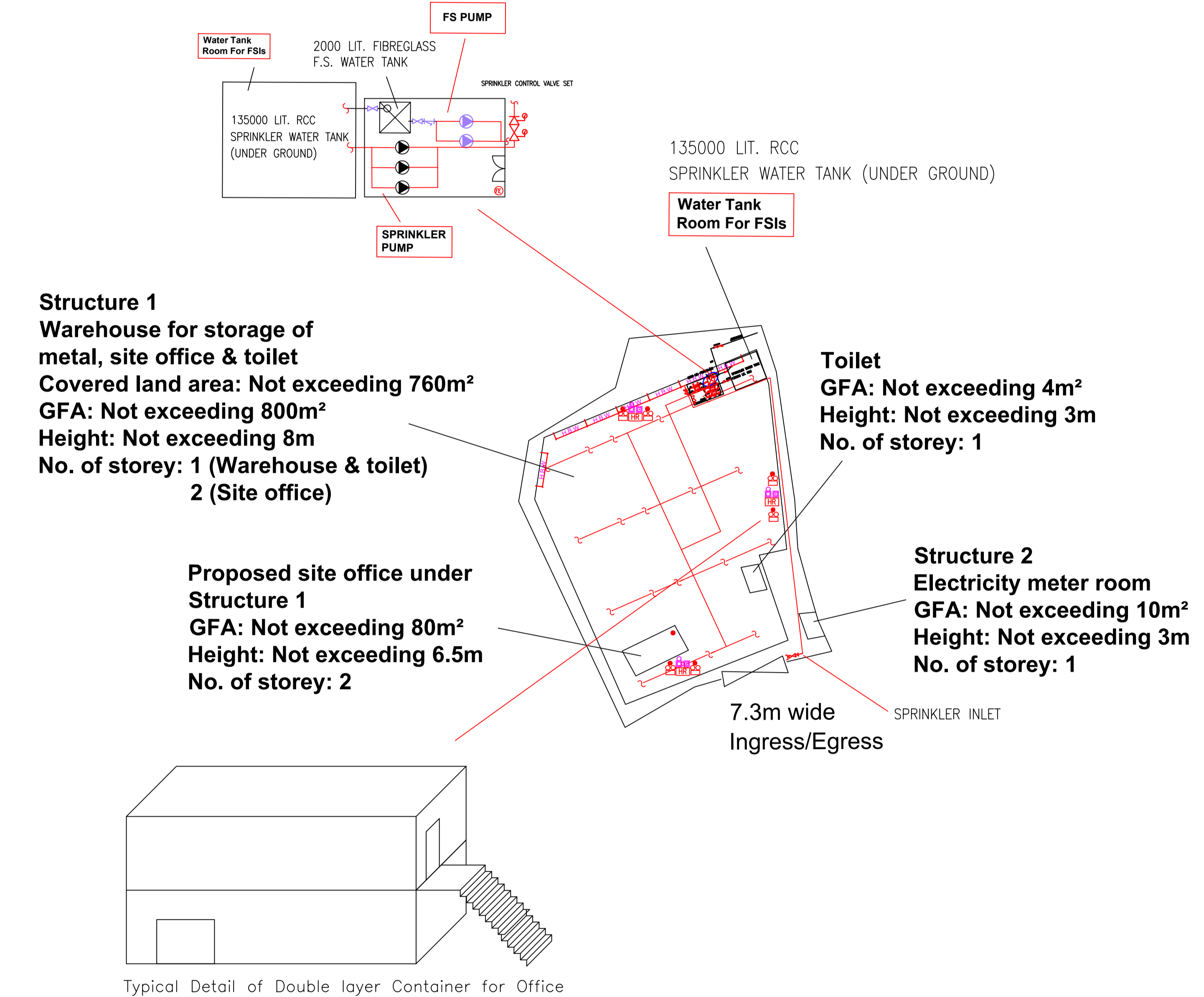

PROJECT : Proposed Temporary Warehouse for Storage of Metal for a Period of 3 Years & Filling of Land at Lot 554 S.A ss.2 (Part) in D.D.77, Ng Chow South Road, Ta Kwu Ling, N.T.	DRAWING TITLE : F.S. Notes, Legend, Fire Service Installation Layout Plan	ARCHITECT :	CONSULTANT :	FIRE SERVICE CONTRACTOR :	DRAWN BY	NAME	DATE	DRAWING NO :	REV.
				Century Fire Service Engineering Co., Ltd.	C.K.NG	13 APR 2024	FS-01	0	
					CHECKED BY			SCALE :	1 : 350 @ (A1)
					APPROVED BY			SOURCE :	B.O.O. Ref. BD F.S.D. Ref. FP
REV	DESCRIPTION	DATE							