

Annex B

Updated Traffic Impact Assessment



**Proposed Minor Relaxation of Building Height
Restriction for the Permitted Educational Institution
(New Science Building) in “Government, Institution
or Community” Zone at Lingnan University, No. 8
Castle Peak Road – Lingnan, Tuen Mun**

**Traffic Impact Assessment
TIA Report
January 2025**

Proposed Minor Relaxation of Building Height Restriction for the Permitted Educational Institution (New Science Building) in “Government, Institution or Community” Zone at Lingnan University, No. 8 Castle Peak Road – Lingnan, Tuen Mun

Traffic Impact Assessment TIA Report January 2025

Contents Amendment Record

This report has been issued and amended as follows:

Revision	Description	Prepared / Date	Checked / Date	Approved / Date
0	Draft TIA Report	10/07/2024 LL	11/07/2024 DP	12/07/2024 OC
0b	Draft TIA Report	04/08/2024 LL	22/08/2024 DP	22/08/2024 OC
1	TIA Report	18/10/2024 CS,NL	05/11/2024 DP	06/11/2024 OC
1a	TIA Report	11/11/2024 CS,NL	12/11/2024 DP	12/11/2024 OC
1b	TIA Report	22/11/2024 CS,NL	25/11/2024 DP	25/11/2024 OC
2	TIA Report	06/01/2025 CS,NL	08/01/2025 DP	08/01/2025 OC

CONTENT

	Page
1 INTRODUCTION	1
1.1 Background	1
1.2 Study Objectives	1
1.3 Report Structure	2
2 PROPOSED NEW BUILDING	3
2.1 Site Location and Study Area	3
2.2 The Proposed New Building	3
2.3 Vehicular and Pedestrian Access Arrangements	3
2.4 Proposed Parking and Loading/ Unloading Provisions	3
3 EXISTING TRAFFIC CONDITION	5
3.1 Existing Road Network	5
3.2 Existing Public Transport Services	5
3.3 Traffic Surveys	7
3.4 Existing Vehicular Traffic Conditions	7
3.5 Existing Pedestrian Flows	10
3.6 Public Transport Surveys	11
4 FUTURE TRAFFIC SITUATION	13
4.1 Design Year	13
4.2 Methodology	13
4.3 Historical Traffic Growth	14
4.4 2031 Background Traffic Flows	15
4.5 2031 Reference Traffic Flows	15
4.6 Development Trip Generations	18
4.7 Design Years Traffic Flows	19
5 TRAFFIC IMPACT ASSESSMENT	20
5.1 Vehicular Traffic Impact Assessment	20
5.2 Pedestrian Assessment	22
5.3 Public Transport Capacity	23
6 SUMMARY AND CONCLUSION	25
6.1 Summary	25
6.2 Conclusions	26

LIST OF TABLES

	Page	
Table 2-1	Development Parameters of the Proposed New Building	3
Table 3-1	Public Transport Services in the Study Area	5
Table 3-2	Summary of Comprehensive Surveys	7
Table 3-3	Passenger Car Unit Conversion Factors	7
Table 3-4	2024 Peak Hour Performance at Key Junctions	8
Table 3-5	2024 Peak Hour Performances of Key Road Links	9
Table 3-6	Existing Level of Services (LOS) of Pedestrian Footways	10
Table 3-7	Capacity Assessment on Cautionary Crossing	10
Table 3-8	Capacity Assessment on Signalized Crossing	10
Table 3-9	2024 Weekday Peak Hour Public Transport Trips and Occupancies	11
Table 4-1	Average Annual Daily Traffic from Annual Traffic Census	14
Table 4-2	2019-Based TPEDM for Northwest New Territories	15
Table 4-3	Planned Developments and Peak Hour Development Traffic	16
Table 4-4	Visitor Trips for the Proposed New Building	18
Table 4-5	Estimated Peak Hour Development Traffic	18
Table 5-1	2031 Peak Hour Performance at Key Junctions	20
Table 5-2	2031 Peak Hour Performance at Road Links	20
Table 5-3	2031 Level of Services (LOS) of Pedestrian Footways	22
Table 5-4	2031 Capacity Assessment on Cautionary Crossing	23
Table 5-5	2031 Capacity Assessment on Signalized Crossing	23
Table 5-6	Peak Hour PT Demand and Spare Capacities	24

LIST OF FIGURES

Figure 2-1	Site Location and Study Area
Figure 2-2	Proposed Vehicular and Pedestrian Access Arrangement at Ground Floor
Figure 3-1	Existing Public Transport Inventory
Figure 3-2	Locations of Survey (Sheet 1 of 2)
Figure 3-3	Locations of Survey (Sheet 2 of 2)
Figure 3-4	2024 Observed Peak Hour Traffic Flows
Figure 3-5	2024 Observed Pedestrian Flows
Figure 4-1	2031 Reference Peak Hour Traffic Flows
Figure 4-2	Peak Hour Development Traffic Flows
Figure 4-3	2031 Design Peak Hour Traffic Flows
Figure 5-1	2031 Design Scenario Pedestrian Flows

ANNEXES

Annex A	Swept Path Assessment Results
Annex B	Layout of Junctions
Annex C	2024 Junction Calculation Sheets
Annex D	2031 Junction Calculation Sheets
Annex E	Queue Length Assessment

1 INTRODUCTION

1.1 Background

- 1.1.1 To facilitate the future demand of the University community, a New Science Building is proposed within the Tuen Mun Campus of the Lingnan University. The proposed new building intends to provide more floor spaces for general education purpose, as well as to provide specialized spaces such as computer laboratories, lecture rooms, offices, acoustic laboratories and a museum/exhibition space.
- 1.1.2 The proposed new building is bounded by Wing On Plaza in the North, Leung Kau Kui Building in the East, and the Main Building in the West.
- 1.1.3 Ozzo Technology (HK) Limited is commissioned to undertake a Traffic Impact Assessment (TIA) Study, to assess the traffic impact to be induced by the academic building on the road network in the vicinity of the site.

1.2 Study Objectives

- 1.2.1 The objectives of the TIA study are as follows:
- To review the existing traffic situation of the surrounding road network;
 - To estimate the potential traffic generations/attractions to be induced by the new building;
 - To assess the future traffic situation of the surrounding road network;
 - To appraise the potential traffic impact of the new building on the surrounding road network and to recommend improvement proposals, if required; and
 - To advise on the internal transport arrangements.

1.3 Report Structure

1.3.1 Following this introductory chapter, this report is arranged as follow:

- Chapter 2 describes the proposed new building;
- Chapter 3 summarizes the existing traffic condition in the vicinity of the site;
- Chapter 4 provides traffic forecast in the future design year;
- Chapter 5 presents the traffic impact assessment results;
- A summary of the findings and conclusion of this TIA study are given in Chapter 6.

2 PROPOSED NEW BUILDING

2.1 Site Location and Study Area

- 2.1.1 The proposed new building is located within the campus of the Lingnan University in Tuen Mun, bounded by Wing On Plaza in the North, Leung Kau Kui Building in the East, and the Main Building in the West. Location of the new building and the proposed Study Area for this TIA Study is presented in **Figure 2-1**.

2.2 The Proposed New Building

- 2.2.1 **Table 2-1** summarizes the development parameters of the proposed new building.

Table 2-1 Development Parameters of the Proposed New Building

Parameters	Proposed
Total GFA	Approx. 11,000m ²
Design Capacity	858 persons (685 student +173 staff)

2.3 Vehicular and Pedestrian Access Arrangements

- 2.3.1 With the new building is located within the existing campus of Lingnan University, the building is generally connected to the internal road network of Lingnan University. **Figure 2-2** presents the proposed vehicular and pedestrian access arrangement for the new building.
- 2.3.2 As presented in **Figure 2-2**, an emergency vehicular access (EVA) is located at the eastern section of the building, which also acts as the vehicular connection for VIP traffic. Remaining pick-up / drop-off activities for the new building will be conducted at the existing internal road at the southeast side of the new building. **Annex A** presents the swept path analysis for the newly proposed EVA.

2.4 Proposed Parking and Loading/ Unloading Provisions

- 2.4.1 As there are no specific parking and loading / unloading requirements for universities in accordance to Hong Kong Planning Standard and Guidelines (HKPSG), provision of ancillary parking facilities should be designed based on users' requirements to meet operational needs.

- 2.4.2 The proposed new building will serve as a research and academic building within the current campus. With provision of current internal parking and loading / unloading facilities are sufficient to serve the operation of the university site, additional provision of parking facilities are generally not required for both options to meet operational needs. Loading and unloading arrangement (such as shared-use of loading / unloading facilities) will be further reviewed in further detailed design.

3 EXISTING TRAFFIC CONDITION

3.1 Existing Road Network

- 3.1.1 **Figure 2-1** shows the location of the proposed new building and the existing road network in the vicinity of the site.
- 3.1.2 Castle Peak Road – Lingnan, a dual-2 carriageway, is classified as a District Distributor which connects Castle Peak Road – Lam Tei in the north and Castel Peak Road – San Hui in the south. Acting as a part of the Castle Peak Road network, the capacity carriageway is currently serving considerable public transport services, with bus and GMB stops identified for section near Lingnan University.
- 3.1.3 Tuen Kwai Road is a single-2 carriageway connecting Fu Tai Estate in the east and Castle Peak Road – Lingnan in the west. Acting as a local road serving adjacent residential site and Lingnan University, bus and GMB stops are generally identified along the carriageway.
- 3.1.4 Fu Tei Road is a single-2 local carriageway (with a single lane configuration for section east of “Forward Living”) connecting Castle Peak Road – Lingnan in the west. The captioned carriageway is currently connected to the southern vehicular entrance of Lingnan University campus.

3.2 Existing Public Transport Services

- 3.2.1 The area is well served by public transport services including MTR, franchised bus, Green Minibus and Red Minibus services. **Table 3-1** summarized the public transport services serving the area and **Figure 3-1** shows the locations of the bus/GMB stops in the vicinity of the site. MTR Siu Hong Station is located within a distance of about 750 meters (around 11 min walking time) as indicated in **Figure 3-1**.

Table 3-1 Public Transport Services in the Study Area

Route No.	Terminating Points		Remarks
Franchised Bus Services			
KMB 53	YOHO Mall (Yuen Long)	Tsuen Wan (Nina Tower)	Daily services every 25-35 mins
KMB 67A	Tuen Mun (Po Tin Estate)	Kwai Fong (Kwai Tsui Estate)	Daily services every 20-30 mins
KMB 67M	Tuen Mun (Siu Hong Court)	Kwai Fong Station	Daily services every 5-20 mins
KMB 67X	Tuen Mun (Siu Hong Court)	Mong Kok East Station	Daily services every 7-25 mins

Route No.	Terminating Points		Remarks
KMB 258P	Hung Shui Kiu (Hung Fuk Estate)	Lam Tin Station	Monday to Saturday services from 06:50 to 10:00, every 12-30 mins
KMB 261	Fanling (Cheung Wah)	Tuen Mun (Sam Shing Estate)	Daily services every 15-30 mins
KMB 267X	Tuen Mun (Siu Hong Court)	Lam Tin Station	Weekday services at 07:25, 07:45
KMB 960A	Central	Hung Shui Kiu (Hung Fuk Estate)	Weekday services at 18:30
KMB 960C	Tuen Mun (Fu Tai Estate)	Causeway Bay (Victoria Park)	Weekday services at 07:00, 07:15
KMB 960S	Tuen Mun (Fu Tai Estate)	Causeway Bay (Victoria Park)	Monday to Saturday services from 07:10-08:00, every 10-15 mins
KMB 960X	Quarry Bay (King's Road)	Hung Shui Kiu (Hung Fuk Estate)	Weekday services from 17:30-19:30, every 10-15 mins
LWB A33X	Tuen Mun (Fu Tai Estate)	Airport (Ground Transportation Centre)	Daily services every 15-30 mins
LWB A33X*	Tuen Mun (Fu Tai Estate)	Cathay Pacific City	Daily services at 06:45, 07:45
LWB E33P	Siu Hong Station (South)	Airport (Ground Transportation Centre)	Daily services every 12-45 mins
LWB NA33	Tuen Mun (Fu Tai Estate)	Cathay Pacific City	Daily services at 00:17, 00:32, 00:47, 01:07, 01:32, 02:15
CTB B3A	Shenzhen Bay Port	Shan King Estate	School Days service at 06:50, 07:15 and every 30-60 mins from 07:55-23:35 School Holidays service at 06:50 and every 30-60 mins from 07:55-23:35 Weekend and Public Holiday services every 15-30 mins
MTR Feeder Bus			
K51	Fu Tai	Tai Lam	Daily services every 5-20 mins
K51A	Fu Tai	So Kwun Wat Tsuen	Daily services from 07:00-20:00, every 30 mins
K58	Fu Tai	Castle Peak Bay	Monday to Saturday services from 06:30-20:00, every 8-25 mins
Green Minibus Services			
46	Fu Tai Estate	Tuen Mun Town Centre (Circular)	Daily services every 7-30 mins
46X	Fu Tai Estate	Tuen Mun Town Centre (Circular)	Daily services every 5-30 mins
Red Minibus Services			
--	Yuen Long	Chi Lok Garden	Daily services from 07:00 - 23:00
--	Yuen Long	Jorden Road	24-hour daily service
--	Mong Kok (Reclamation Street)	Yuen Long	Daily services from 12:00 - 06:15 (the next morning)

3.3 Traffic Surveys

3.3.1 Comprehensive traffic surveys including vehicular count survey, pedestrian count survey, public transport surveys were conducted on 27 June 2024 (Thursday) between 07:00 to 10:00 (AM peak period) and 16:00 to 19:00 (PM peak period), **Table 3-2** provides a summary of the types of surveys being undertaken and the survey locations are shown in **Figure 3-2** and **Figure 3-3**.

Table 3-2 Summary of Comprehensive Surveys

Survey Type	Location	Figure	Survey Date	Data Collected
Vehicular Count Surveys	J1 to J6	Figure 3-2	2024-06-27 (Thursday)	Manual Classified count in 15 min intervals
	L1 to L4	Figure 3-2	2024-06-27 (Thursday)	Manual Classified count in 15 min intervals
Pedestrian Count Surveys	P1 to P7	Figure 3-3	2024-06-27 (Thursday)	Pedestrian flows in 5-min intervals
Bus / GMB Surveys	Bus/GMB Stop A to D	Figure 3-3	2024-06-27 (Thursday)	- Nos. of buses - Passenger boarding and alighting - Vehicle occupancy

3.4 Existing Vehicular Traffic Conditions

3.4.1 All vehicle flows in the subsequent analysis have been converted to passenger car unit (PCU) based on the PCU factors as indicated in Table 2.3.1.1 of Volume 2 of Transport Planning and Design Manual (TPDM) and shown in **Table 3-3**.

Table 3-3 Passenger Car Unit Conversion Factors

Vehicle Type	PCU Conversion Factor	
	Traffic Signal	Priority
Car / Taxi	1.00	1.00
Public Light Bus / Minibus	1.50	1.50
Light Goods Vehicle	1.50	1.50
Medium/ Heavy Goods Vehicle	1.75	2.80
Bus / Coach	2.00	2.80

Source: Table 2.3.1.1, Chapter 2.3, Volume 2, TPDM-2024

- 3.4.2 By applying the above PCU factors, vehicular traffic flows in PCUs are calculated and the AM peak hour (08:00 – 09:00) and PM peak hour (17:15 – 18:15) traffic flows on the road network in the vicinity of the site 2024 are shown in **Figure 3-4**.
- 3.4.3 Based on the 2024 observed peak hour traffic flows, the performances of the key junctions are assessed and the assessment results are indicated in **Table 3-4**. The junction layouts are included in **Annex B**. Detailed junction calculation sheets are given in **Annex C**.

Table 3-4 2024 Peak Hour Performance at Key Junctions

Jn. ID.	Location	Type	Capacity Index ⁽¹⁾	2024	
				AM Peak	PM Peak
J1	Castle Peak Road – Lingnan / Castle Peak Road – Lam Tei	Signal	RC	85.6%	100%+
J2	Lam Tei Interchange	Roundabout	DFC	0.61	0.50
J3	Tuen Kwai Road / Northern Access of Lingnan University	Priority	DFC	0.01	0.04
J4	Castle Peak Road – Lingnan / Tuen Kwai Road	Signal	RC	100%+	100%+
J5	Castle Peak Road – Lingnan / Fu Tei Road	Priority	DFC	0.12	0.13
J6	Fu Tei Road / Southern Access of Lingnan University	Priority	DFC	0.01	0.04

Notes: (1) The Capacity Index for Signal controlled junction is the Reserve Capacity (RC)
The Capacity Index for Priority Junction and Roundabout is Design Flow to Capacity Ratio (DFC)

- 3.4.4 The results of the junction assessments show that all the key junctions in the vicinity of the site operate within capacity during both the AM and PM peak hours in 2024.

3.4.5 Based on the 2024 observed peak hour traffic flows, the peak hour performance of the key links in the vicinity of the site are also assessed. The assessment results are indicated in **Table 3-5**.

Table 3-5 2024 Peak Hour Performances of Key Road Links

Link ID.	Section ⁽¹⁾	Direction	Design Capacity (veh/hr)	Flows (veh/hr)	2024	
					AM Peak	PM Peak
L1	Castle Peak Road – Lam Tei	NB	2800	Flows	806	993
				P/Df ⁽²⁾	0.29	0.35
		SB	2800	Flows	1535	1090
				P/Df ⁽²⁾	0.55	0.39
L2-1	Yuen Long Highway (Main Road)	EB	4700	Flows	3860	4280
				P/Df ⁽²⁾	0.82	0.91
L2-2	Yuen Long Highway (Main Road)	WB	3000	Flows	2043	3069
				P/Df ⁽²⁾	0.68	1.02
L2-3	Yuen Long Highway (Slip Road to Castle Peak Road – Lingnan)	WB	3000	Flows	1293	1013
				P/Df ⁽²⁾	0.43	0.34
L3	Castle Peak Road – Lingnan (Section north of Fu Hang Road)	NB	1700	Flows	1249	973
				P/Df ⁽²⁾	0.73	0.57
		SB	1700	Flows	358	309
				P/Df ⁽²⁾	0.21	0.18
L4	Castle Peak Road – Lingnan (Section south of Fu Tei Road)	EB	1700	Flows	145	218
				P/Df ⁽²⁾	0.09	0.13
		WB	1700	Flows	647	414
				P/Df ⁽²⁾	0.38	0.24
L5	Fu Tei Road	EB	400	Flows	38	33
				P/Df ⁽²⁾	0.10	0.08
		WB	400	Flows	22	48
				P/Df ⁽²⁾	0.06	0.12

Notes: (1) Refer to Figure 3-2 for locations of the key links

(2) P/Df = Peak Hourly Flows/Design Flow Ratios (P/Df) for road links

3.4.6 The results show that the key road links in the vicinity of the site operate within capacity during peak hours in 2024, except Yuen Long Highway (L2-1, L2-2) during PM peak time.

3.5 Existing Pedestrian Flows

3.5.1 **Figure 3-5** shows the observed peak hour pedestrian flows along the main pedestrian routes on a normal weekday (07:00-10:00 and 16:00-19:00) for the AM and PM peak hour respectively).

3.5.2 The levels of services of the above key pedestrian links are assessed based on the highest 5-min pedestrian flows being observed during the survey period, with the results are presented in **Table 3-6** to **Table 3-8**.

Table 3-6 Existing Level of Services (LOS) of Pedestrian Footways

Location ⁽¹⁾	Effective Footway Width ⁽²⁾	2024 Weekday		
		Peak 5-Min Flow	Peak Min Flows/Metre	Level of Service ⁽³⁾
P1	2.5m	59	4.7	A
P2	1.5m	69	9.2	A
P4	2.5m	71	5.7	A
P5	2.65m	18	1.4	A
P7	2.12m	70	6.7	A

Notes:

(1) Refer to Figure 3-5 for locations of key pedestrian links

(2) Effective width = Actual width minus 0.5m shy zone

(3) LOS of footpath refers to Highway Capacity Manual 2000 Exhibit 18-3.

Table 3-7 Capacity Assessment on Cautionary Crossing

Location ⁽¹⁾	Crossing Width	Maximum Capacity ⁽²⁾ (ped/hr)	Demand (ped/hr)	Demand / Capacity Ratio
P6 (2024AM)	4m	4800	336	0.070
P6 (2024PM)	4m	4800	684	0.143

Notes:

(1) Refer to Figure 3-5 for location of cautionary crossing.

(2) Capacity of pedestrian crossing in accordance with Table 3.7.2.1, Chapter 3.7, Volume 2, TPDM.

Table 3-8 Capacity Assessment on Signalized Crossing

Location ⁽¹⁾	W Crossing Width	PG (sec)	CT (sec)	GTP	PC ⁽²⁾ (ped/hr)	Demand (ped/hr)	Demand / Capacity Ratio
P3 (2024AM)	3.6m	25	118	0.212	1449	441	0.304
P3 (2024PM)	3.6m	25	118	0.212	1449	385	0.266

Notes:

(1) Refer to Figure 3-5 for location of cautionary crossing.

(2) Capacity of pedestrian crossing in accordance with Chapter 3.2.5, Volume 4, TPDM

where PG = Pedestrian Green + Flashing Green

CT = Cycle Time

GTP = Green time proportion (i.e. PG/CT)

PC = Pedestrian crossing capacity = $K (1900) \times GTP \times W$

3.5.3 Assessment results show that LOS A are achieved at all the key pedestrian links in the vicinity of the site, while the crossings are operating within capacity.

3.6 Public Transport Surveys

3.6.1 It is noted that visitors access the site are mainly by the bus services at the four nearby bus-stops along Castle Peak Road – Lingnan and Tuen Kwai Road. Hence, bus and GMB surveys were undertaken to record the number of bus and GMB trips and occupancy rate at the four nearby bus/GMB stops (with location shown in Figure 3-3). The peak hour bus trips and patronage results are shown in Table 3-9.

Table 3-9 2024 Weekday Peak Hour Public Transport Trips and Occupancies

Location ⁽¹⁾	Bus / GMB	Nos. of Trips	Passenger per hour						
			Total Carrying Capacity	Total Arrivals ⁽²⁾	Alighting at stop	Boarding at stop	Total Departures ⁽²⁾	Spare Capacity	
Weekday AM Peak Hour (08:00 – 09:00)									
A	Castle Peak Road, Lingnan University (North Bound)	Bus	13	3,173	616	21	135	502	2,671
		GMB	12	219	113	0	8	105	114
B	Castle Peak Road, Lingnan University (South Bound)	Bus	31	3,997	1,339	115	17	1,437	2,560
		GMB	15	270	258	2	0	260	10
C	Tuen Kwai Road, Beneville (East Bound)	Bus	27	3,208	500	0	169	331	2,877
		GMB	11	314	58	0	9	49	265
D	Tuen Kwai Road, Beneville (West Bound)	Bus	17	2,144	273	480	0	753	1,391
		GMB	13	241	209	0	0	209	32
Overall Bus			88	12,522	2,728	616	321	3,023	9,499
Overall GMB			51	1,044	638	2	17	623	421

Location ⁽¹⁾	Bus / GMB	Nos. of Trips	Passenger per hour						
			Total Carrying Capacity	Total Arrivals ⁽²⁾	Alighting at stop	Boarding at stop	Total Departures ⁽²⁾	Spare Capacity	
Overall		139	13,566	3,366	618	338	3,646	9,920	
Weekday PM Peak Hour (17:15 – 18:15)									
A	Castle Peak Road, Lingnan University (North Bound)	Bus	32	4,095	1,065	66	117	1,014	3,081
		GMB	14	254	240	0	18	222	31
B	Castle Peak Road, Lingnan University (South Bound)	Bus	25	3,082	624	288	9	903	2,179
		GMB	10	184	117	6	0	123	61
C	Tuen Kwai Road, Beneville (East Bound)	Bus	13	1,607	588	0	254	334	1,273
		GMB	13	235	186	0	22	164	71
D	Tuen Kwai Road, Beneville (West Bound)	Bus	12	1,254	88	90	0	178	1,076
		GMB	9	380	108	2	0	110	270
Overall Bus		82	10,038	2,365	444	380	2,429	7,609	
Overall GMB		46	1,053	651	8	40	619	434	
Overall		128	11,091	3,016	452	420	3,048	8,043	

Notes:

(1) Refer to Figure 3-1 for location of surveyed bus/GMB stops.

(2) Total passengers of arriving and departing buses/GMB

3.6.2 Survey results indicate a spare public transport capacity of around 9,920 passengers and 8,043 passengers for AM and PM peak respectively.

4 FUTURE TRAFFIC SITUATION

4.1 Design Year

- 4.1.1 The planned completion year of the proposed new building is 2028, hence, the “Design Year” for this TIA study is set as 2031, i.e. 3 years after the completion year.

4.2 Methodology

- 4.2.1 In forecasting the future traffic flows on the road network in the Study Area, references are made to the following sources of information which include:

- Historical traffic data from Annual Traffic Census (ATC);
- The forecast population and employment from the 2019-based Territorial Population and Employment Data Matrix (TPEDM) planning data published by Planning Department; and
- Committed and Planned developments in the Study Area.

- 4.2.2 The following steps are undertaken to derive the 2031 Peak Hour Reference Flows (i.e. without the proposed new building) and Design Flows (i.e. with the proposed new building):

2031 Background Flows = 2024 Observed Flows x annual growth factors

2031 Reference Flows = 2031 Background Flows + additional traffic generated by planned developments

2031 Design Flows = 2031 Reference Flows + additional traffic generated by the new building

- 4.2.3 In particular, the operation traffic impact to be induced by the proposed new building is assessed by comparing the 2031 Peak Hour Reference Traffic Flows against the 2031 Design Traffic Flows.

4.3 Historical Traffic Growth

4.3.1 To gain an understanding of the historical trends of traffic growth on the nearby road network, relevant traffic data over the 5-year period of 2017 to 2022 are extracted from the Annual Traffic Census (ATC) Reports for the ATC stations in the Study Area. **Table 4-1** describes the locations of the ATC stations and provides the corresponding traffic data.

Table 4-1 Average Annual Daily Traffic from Annual Traffic Census

Station	Road	Between		2017	2018	2019	2020	2021	2022	Average Growth Rate p.a.
5025	Yuen Long Highway	Hung Tin Rd INT	Lam Tei INT	121360	125230	126570	117560	123290	117820	-0.59%
				-	3.19%	1.07%	-7.12%	4.87%	-4.44%	
5202	Castle Peak Rd – San Hui	Chung Wong Toi INT	Fu Tei Rd	9010	10030	11350	10880	11320	10980	4.03%
				-	11.32%	13.16%	-4.14%	4.04%	-3.00%	
5296	Castle Peak Rd – Lingnan	Fu Tei Rd	Lam Tei INT	11100	11250	12140	11550	12120	11580	0.85%
				-	1.35%	7.91%	-4.86%	4.94%	0.85%	
5404	Tuen Mun Rd	Chung Wong Toi INT	Lam Tei INT	105650	108160	109220	103100	113690	109410	0.70%
				-	2.38%	0.98%	-5.6%	10.27%	0.70%	
Total				247,120	254,670	259,280	243,090	260,420	249,790	0.22%
				-	3.06%	1.81%	-6.24%	7.13%	-4.08%	

Source: 2017-2022 Annual Traffic Census (ATC) Reports published by Transport Department

4.3.2 As indicated in **Table 4-1**, an annual growth rate of 0.22% per annum on the road network in the vicinity of the site over the period from 2017 – 2022.

4.3.3 Reference is also made to the 2019-based Territorial Population and Employment Data Matrix (TPEDM) planning data published by Planning Department. **Table 4-2** presents the population and employment data in Northwest New Territories for 2019, 2026 and 2031.

Table 4-2 2019-Based TPEDM for Northwest New Territories

Category	2019	2026	2031	% Growth p.a.
				2019 - 2031
Population	1,154,400	1,233,700	1,396,650	1.60%
Employment	292,350	320,850	393,100	2.50%
Total	1,446,750	1,554,550	1,789,750	1.79%

Source: 2019-based TPEDM published by Planning Department.

4.3.4 As shown in the table, the predicted growth of population and employment in Northwest New Territories from 2019 to 2031 is approximately +1.79% per annum respectively.

4.4 2031 Background Traffic Flows

4.4.1 Taking into account the above factors, it is proposed to adopt an average growth rate of +1.79% per annum with reference to the growth of population and employment in the area as shown in **Table 4-2** to estimate the 2028/2031 peak hour Background Traffic Flows in the Study Area.

4.5 2031 Reference Traffic Flows

4.5.1 According to the published information, **Table 4-3** presents a list of the planned and committed developments in the vicinity of the Study Area. The table also shows the estimated peak hour traffic to be generated by these developments.

Table 4-3 Planned Developments and Peak Hour Development Traffic

Location		Use	Traffic Flows (pcu/hour)			
			Weekday AM Peak		Weekday PM Peak	
			In	Out	In	Out
1	Tuen Mun Area 29 West, Tuen Mun, New Territories [ATM/547]	PRH (1,020 flats) ⁽¹⁾	33	44	31	24
		Residential Care Homes for the Elderly (2,100m ² GFA) ⁽²⁾	2	2	3	4
		Clinic/ Community Health Centre	11	10	13	17
2	Site 1 and 1A, Tuen Mun Area 54, New Territories [ATM/500] ⁽³⁾	PRH (4,232 flats) ⁽¹⁾	138	183	127	100
		Retail (2,420 m ² GFA) ⁽¹⁾	6	6	8	8
		Social Welfare Facilities ⁽²⁾ (1,060m ² GFA)	1	1	1	1
		Kindergarten (1 no.)	10	10	10	10
3	Site 2, Tuen Mun Area 54, New Territories	PRH (4,688 flats) ⁽¹⁾	153	203	141	111
		Retail (4,250 m ² GFA) ⁽¹⁾	10	10	15	13
		Social Welfare Facilities ⁽²⁾ (3,600m ² GFA)	2	3	2	2
4	Site 3 and 4 (East), Tuen Mun Area 54, New Territories [ATM/499] ⁽³⁾	PRH (5,183 flats) ⁽¹⁾	169	224	156	123
		Retail (3,130m ² GFA) ⁽¹⁾	8	7	10	11
		Social Welfare Facilities ⁽²⁾ (1,810m ² GFA)"	1	1	1	1
		Kindergarten (1 no.)	10	10	10	10
5	Site 3 and 4 (West), Tuen Mun Area 54, New Territories ⁽³⁾	Private Housing R(A) ⁽¹⁾ (3,215 flats)	195	340	190	137
6	Site 4 (South), Tuen Mun Area 54, New Territories ⁽³⁾	PRH (1,400 flats) ⁽¹⁾	46	60	42	33
		Kindergarten (1no.) ⁽²⁾	10	10	10	10
7	Site 5, Tuen Mun Area 54, New Territories ⁽³⁾	SSF (1,000 flats) ⁽¹⁾	43	62	40	30
		Social Welfare Facilities ⁽²⁾ (1,300m ² GFA)"	1	1	1	1
8	Site 4A (East), Tuen Mun Area 54, New Territories ⁽⁴⁾	Light Public Housing ⁽⁵⁾ (Around 5300 units, Total GFA 50,297 m ² average flat size 17m ²)	25	38	74	59
	Site 4A (West), Tuen Mun Area 54, New Territories ⁽⁴⁾					
9	San Hing Road Phase I ⁽⁶⁾	PRH (1,500 flats) ⁽⁶⁾	49	65	45	36
	San Hing Road Phase II A ⁽⁶⁾	PRH (3,600 flats) ⁽⁶⁾	117	156	108	85
	San Hing Road Phase II B ⁽⁶⁾	PRH (5,800 flats) ⁽⁶⁾	189	251	175	137
10	Hong Po Road Development ⁽⁶⁾	PRH (9,500 flats) ⁽⁶⁾	310	410	286	225

	Location	Use	Traffic Flows (pcu/hour)			
			Weekday AM Peak		Weekday PM Peak	
			In	Out	In	Out
11	Lots 531 RP, 532 S.D RP and 532 RP in D.D. 130 and Adjoining Government Land, Lam Tei, Tuen Mun, New Territories [A/TM-LTY/426]	Private Housing ⁽¹⁾ (184 flats)	8	13	7	5
		Retail ⁽¹⁾ (67.59 m ² GFA)	16	16	24	21
12	Various Lots in D.D. 130 and Adjoining Government Land, Lam Tei, Tuen Mun, New Territories [Y/TM-LTY/11] ⁽⁷⁾	Private Housing (1,385 flats)	37	63	29	22
13	Lot No. 2011 (Part) in D.D. 132, Tuen On Lane, Tuen Fu Road, Fu Tei, Tuen Mun (Gig Lok Monastery) [A/TM/530] ⁽⁸⁾	1567 Niches 1089 Tablets	7	7	7	7
14	Lots 220 RP and 221 in D.D.130, San Hing Road, San Hing Tsuen, Tuen Mun, New Territories [Y/TM-LTY/10] ⁽⁹⁾	Private Housing (288 flats)	37	46	30	28
Total			1644	2252	1596	1271

Notes:

- (1) AM and PM Peak Hour trip rates extracted from TPDM Volume 1, Chapter 3, Annex C.
- (2) Trip generations and attraction extracted from TIA reports of respective approved planning applications (A/TM/499, A/TM/500 and A/TM/547)
- (3) The traffic impact assessment for Tuen Mun Area 54 development is undertaken by Civil Engineering and Development Department (Agreement No.CE38/2011(CE)) in 2011, and was review and updated by Hong Kong Housing Authority for planning application A/TM/499 and A/TM/500 with increase of plot ratio.
- (4) Information is extracted from district councils document:
https://www.districtcouncils.gov.hk/tm/doc/2020_2023/en/committee_meetings_doc/dfmehc/23449/dfmehc_2023_002.pdf
- (5) Trip generations and attractions are calculated based on TPDM Volume 1 Chapter 3, Appendix, Annex C, Table 1, lower limit of Public Housing (average Flat Size of 30 sqm)
- (6) Information is extracted from district councils document:
https://www.districtcouncils.gov.hk/tm/doc/2020_2023/en/dc_meetings_doc/23419/dc_2023_019.pdf
- (7) Trip generations and attraction extracted from TIA reports of respective approved planning applications Y/TM-LTY/11.
- (8) Trip generations and attraction extracted from TIA reports of respective approved planning applications A/TM/530.
- (9) Trip generations and attraction extracted from TIA reports of respective approved planning applications Y/TM-LTY/10.

4.5.2 The additional development trips by the planned developments are then added to the 2028 / 2031 peak hour Background Traffic Flows to derive the 2028 / 2031 peak hour Reference Traffic Flows (i.e., without the Proposed Redevelopment) and the results are shown in **Figure 4-1**.

4.6 Development Trip Generations

Peak Hour Visitor Flows

- 4.6.1 With reference to the visitor survey conducted at the Lingnan University Tuen Mun campus on 27 Jun 2024, the visitor trips for the proposed new building is presented in **Table 4-4**.

Table 4-4 Visitor Trips for the Proposed New Building

Site	Observed Peak Hour Visitor Trips (visitors / hr)			
	Weekday AM (08:30-9:30)		Weekday PM (17:35-18:35)	
	In	Out	In	Out
Existing Lingnan University Tuen Mun Campus (No. 7302 persons)	443	60	49	154
	Observed Peak Hour Visitor Trip Rates (visitors / hr / persons)			
	Weekday AM	Weekday AM	Weekday AM	Weekday AM
	In	Out	In	Out
	0.061	0.008	0.007	0.021
Proposed New Building (No. 858 persons)	Estimated Peak Hour Visitor Trips (visitors / hr)			
	Weekday AM		Weekday PM	
	In	Out	In	Out
	53	7	6	18

Peak Hour Vehicular Flows

- 4.6.2 The proposed new building is an academic building to accommodate a total of 173 staffs. With reference to Traffic Generation Survey 2006 (Trip rate of Lingnan University), the estimated peak hour vehicular flows for the proposed new building are summarized in **Table 4-5**.

Table 4-5 Estimated Peak Hour Development Traffic

Development Type	Adopted Trip Rates				Vehicular Trips for the Site			
	AM Peak Trip Rate (pcu/no. of staffs)		PM Peak Trip Rate (pcu/no. of staffs)		AM Peak Hour Trip (pcu/hr)		PM Peak Hour Trip (pcu/hr)	
	In	Out	In	Out	In	Out	In	Out
University (No. of staffs = 173)	0.0191	0.0280	0.0559	0.0356	4	5	10	7
2-way Total					9		17	

- 4.6.3 With reference to **Table 4-5**, it is anticipated that the proposed new building would induce total two-way traffic of 9 pcu's (4 in and 5 out) and 17 pcu's (10 in and 7 out) in the AM and PM peak hour respectively. The peak hour development traffic flows are assigned to the road network in the Study Area as shown in **Figure 4-2**

4.7 Design Years Traffic Flows

- 4.7.1 By adding the peak hour development flows (**Figure 4-2**) onto the forecast 2031 Peak Hour Reference Flows (**Figure 4-1**), the 2031 Peak Hour Design Flows (i.e. with proposed new building) are derived and shown in **Figure 4-3**.
- 4.7.2 On the other hand, 2028 Peak Hour Flows with construction traffic in place are also derived and shown in **Figure 4-4**.

5 TRAFFIC IMPACT ASSESSMENT

5.1 Vehicular Traffic Impact Assessment

5.1.1 Based on the 2031 Reference Flows (i.e. without proposed new building) and 2031 Design Flows (i.e. with proposed new building), junction and link capacity assessments are undertaken and the results are presented in **Table 5-1** and **Table 5-2**. Detailed calculation sheets for junction assessments are also provided in **Annex D**.

Table 5-1 2031 Peak Hour Performance at Key Junctions

Jn. ID.	Location	Type	Capacity Index ⁽¹⁾	Reference		Design	
				AM Peak	PM Peak	AM Peak	PM Peak
J1	Castle Peak Road – Lingnan / Castle Peak Road – Lam Tei	Signal	RC	50.7%	100%+	50.6%	100%+
J2	Lam Tei Interchange	Roundabout	DFC	0.85	0.68	0.85	0.69
J3	Tuen Kwai Road / Northern Access of Lingnan University	Priority	DFC	0.01	0.04	0.01	0.05
J4	Castle Peak Road – Lingnan / Tuen Kwai Road	Signal	RC	86.4%	100%+	85.2%	100%+
J5	Castle Peak Road – Lingnan / Fu Tei Road	Priority	DFC	0.14	0.15	0.14	0.16
J6	Fu Tei Road / Southern Access of Lingnan University	Priority	DFC	0.01	0.05	0.01	0.06

Notes: (1) The Capacity Index for Signal-controlled junction is Reserve Capacity (RC)
The Capacity Index for Priority Junction and Roundabout is Design Flow to Capacity Ratio (DFC)

Table 5-2 2031 Peak Hour Performance at Road Links

Link ID.	Section ⁽¹⁾	Direction	Design Capacity (veh/hr)	Flows (veh/hr)	2031 Reference		2031 Design	
					AM Peak	PM Peak	AM Peak	PM Peak
L1	Castle Peak Road – Lam Tei	NB	2800	Flows	990	1187	990	1189
				P/Df ⁽²⁾	0.35	0.42	0.35	0.42
		SB	2800	Flows	1802	1296	1802	1296
				P/Df ⁽²⁾	0.64	0.46	0.64	0.46
L2-1	Yuen Long Highway (Main Road)	EB	4700	Flows	4587	4973	4588	4975
				P/Df ⁽²⁾	0.98	1.06	0.98	1.06
L2-2	Yuen Long Highway (Main Road)	WB	3000	Flows	2322	3483	2322	3483
				P/Df ⁽²⁾	0.77	1.16	0.77	1.16
L2-3	Yuen Long Highway (Slip Road to Castle Peak Road – Lingnan)	WB	3000	Flows	1596	1281	1598	1283
				P/Df ⁽²⁾	0.53	0.43	0.53	0.43

Link ID.	Section ⁽¹⁾	Direction	Design Capacity (veh/hr)	Flows (veh/hr)	2031 Reference		2031 Design	
					AM Peak	PM Peak	AM Peak	PM Peak
L3	Castle Peak Road – Lingnan (north section of Fu Hang Road)	NB	1700	Flows	1563	1247	1564	1251
				P/Df ⁽²⁾	0.92	0.73	0.92	0.74
		SB	1700	Flows	411	351	413	358
				P/Df ⁽²⁾	0.24	0.21	0.24	0.21
L4	Castle Peak Road – Lingnan (south section of Fu Tei Road)	EB	1700	Flows	181	258	181	258
				P/Df ⁽²⁾	0.11	0.15	0.11	0.15
		WB	1700	Flows	738	470	742	475
				P/Df ⁽²⁾	0.43	0.28	0.44	0.28
L5	Fu Tei Road	EB	400	P/Df ⁽²⁾	44	38	46	42
				Flows	0.11	0.10	0.12	0.11
		WB	400	P/Df ⁽²⁾	25	55	26	58
				Flows	0.06	0.14	0.07	0.15

Notes: (1) Refer to Figure 3-2 for locations of the key links

(2) P/Df = Peak Hourly Flows/Design Flow Ratios (P/Df) for road links

- 5.1.2 Assessment results for **Table 5-1** and **Table 5-2** indicate that the assessed junctions and links in the vicinity of the site would be operating within capacity during the AM and PM peak hour for both the 2031 Reference (without proposed new building) and Design (with proposed new building) scenarios, except Yuen Long Highway (L2-1, L2-2) with V/C operating between 1.0 and 1.2 during PM peak time.
- 5.1.3 With the development traffic contribution onto the section of Yuen Long Highway is minimal (less than 5 veh/hr), we consider the development traffic impact onto Yuen Long Highway is trivial. **In long run, with highway infrastructures including Route 11 and Tuen Mun Bypass in place, traffic condition Yuen Long Highway will be significantly improved.**
- 5.1.4 To investigate the future traffic queue at Lam Tei Interchange, queuing assessment for J2 was conducted, with findings presented in **Annex E**. Assessment results indicate a sufficient queuing space at J2, even with the development traffic in place (with the development traffic only contribute a trivial queue onto the roundabout)
- 5.1.5 Therefore, it can be concluded that the traffic generated by the proposed new building would not cause adverse traffic impact to the road network in the vicinity of the site.

5.2 Pedestrian Assessment

- 5.2.1 Similar to vehicular traffic impact assessment, year 2031 is adopted as the design year for pedestrian assessment. To derive the background pedestrian flows for design year 2031, an annual growth factor of +1.79% was applied to the existing pedestrian flows to derive the 2031 peak hour background pedestrian flows.
- 5.2.2 The additional pedestrian flows by the proposed new building in Section 4.6.1 are then assigned onto the main pedestrian routes and the resulting 2031 Peak Hour Pedestrian Flows with the proposed new building in place are shown in **Figure 5-1**.
- 5.2.3 Based on the 2024 observed pedestrian flows, the peak 5-min flows are around 10-12% of the peak hour flows. To provide conservative assessment, a factor of 15% is applied to the peak hour pedestrian flows in **Figure 5-1** to derive the peak 5-min flows for the LOS assessment of the major pedestrian links in the vicinity of the site. The results are presented in **Table 5-3** to **Table 5-5**.

Table 5-3 2031 Level of Services (LOS) of Pedestrian Footways

Location ⁽¹⁾	Effective Footway Width ⁽²⁾	2031 Reference Scenario			2031 Design Scenario		
		Peak 5-Min Flow	Peak Min Flows/M	Level of Service ⁽³⁾	Peak 5-Min Flow	Peak Min Flows/M	Level of Service ⁽³⁾
P1	2.5m	66	5.3	A	68	5.4	A
P2	1.5m	70	9.3	A	76	10.1	A
P4	2.5m	81	6.5	A	83	6.6	A
P5	2.7m	27	2.0	A	31	2.3	A
P7	2.1m	81	7.7	A	85	8.1	A

Notes:

(1) Refer to Figure 3-5 for locations of key pedestrian links

(2) Effective width = Actual width minus 0.5m shy zone

(3) LOS of footpath refers to Highway Capacity Manual 2000 Exhibit 18-3.

Table 5-4 2031 Capacity Assessment on Cautionary Crossing

Location ⁽¹⁾	Crossing Width	Maximum Capacity ⁽²⁾ (ped/hr)	Demand (ped/hr)	Demand/ Capacity Ratio
Reference Scenario				
P6 (2031AM)	4	4800	381	0.079
P6 (2031PM)	4	4800	775	0.161
Design Scenario				
P6 (2031AM)	4	4800	397	0.083
P6 (2031PM)	4	4800	784	0.163

Notes:

(1) Refer to Figure 3-5 for location of cautionary crossing.

(2) Capacity of pedestrian crossing in accordance with Table 3.7.2.1, Chapter 3.7, Volume 2, TPDM.

Table 5-5 2031 Capacity Assessment on Signalized Crossing

Location ⁽¹⁾	W Crossing Width	PG (sec)	CT (sec)	GTP	PC ⁽²⁾ (ped/hr)	Demand (ped/hr)	Demand / Capacity Ratio
Reference Scenario							
P3 (2031AM)	3.6	25	118	0.212	1449.153	500	0.345
P3 (2031PM)	3.6	25	118	0.212	1449.153	436	0.301
Design Scenario							
P3 (2031AM)	3.6	25	118	0.212	1449.153	545	0.376
P3 (2031PM)	3.6	25	118	0.212	1449.153	457	0.315

Notes:

(1) Refer to Figure 3-5 for location of cautionary crossing.

(2) Capacity of pedestrian crossing in accordance with Chapter 3.2.5, Volume 4, TPDM

where PG = Pedestrian Green + Flashing Green

CT = Cycle Time

GTP = Green time proportion (i.e. PG/CT)

PC = Pedestrian crossing capacity = $K (1900) \times GTP \times W$

5.3 Public Transport Capacity

5.3.1 With reference to Census 2021 (Table C204), percentage split of visitors using road based public transport services (i.e. bus and minibus) is 33.8%. For conservative, assume 35% of visitors for the site will travel via road based public transport service.

5.3.2 The proposed academic building mainly consists of classrooms, laboratory and lecture theatre to serve existing students and staffs, with total population of Lingnan University maintains the same as existing. Please also be advised that the supporting facilities such as lecture theatre (with capacity of around 100 seats only) are for internal use only, and will not result to increase in visitors to/from Lingnan University. For conservative assessment purpose, additional visitor flows were assumed making reference to the visitor flows derived from section 4.6.1, the anticipated peak hour public transport demand for the proposed building would be 22 (19 in and 3 out) visitors/hr during the AM Peak and 10 (3 in and 7 out) visitors/hr during the PM Peak.

5.3.3 To assess the sufficiency of existing public transport services, **Table 5-6** compares the anticipated additional public transport demand by the site against the spare capacities of bus services to be available during the peak hours. Similar to vehicular and pedestrian traffic, the 2031 bus occupancies are derived by applying an annual growth rate of +1.79% to the 2024 observed peak hour public transport patronage.

Table 5-6 Peak Hour PT Demand and Spare Capacities

	No. of Bus Trips	Total Capacity (Pax/hr)	Direction	2031 Occupancy (Pax/hr)	Spare Capacity (Pax/hr)	Demand for Public ⁽²⁾	Demand for Proposed Building ⁽³⁾ (Pax/hr)
Weekday AM Peak	139	13,566	Arrivals	3,831 ⁽¹⁾	9,735	Alighting 700	Alighting 19
			Departures	3,112 ⁽⁴⁾	10,454 ⁽⁵⁾	Boarding 383	Boarding 3
Weekday PM Peak	128	11,091	Arrivals	3,418 ⁽¹⁾	7,673	Alighting 512	Alighting 3
			Departures	2,903 ⁽⁴⁾	8,188 ⁽⁵⁾	Boarding 476	Boarding 7

Notes: (1) 2031 Occupancy on arrival = 2024 Occupancy (Table 3-9) x (1+1.79%)⁷ + New Building attraction (Table 4-4)

(2) 2031 Public Demand = 2024 total Alighting / Boarding (Table 3-9) x (1+1.79%)⁷

(3) Refer to Table 4-4.

(4) 2031 Occupancy on departure = 2031 Occupancy on arrival – 2031 public alighting - New Building generation

(5) Spare Capacity = Total Capacity - Occupancy

5.3.4 **Table 5-6** indicates that, as the additional public transport demand is not significant, there would be sufficient public transport spare capacities to cope with the additional public transport demand

6 SUMMARY AND CONCLUSION

6.1 Summary

- 6.1.1 Ozzo Technology (HK) Limited is commissioned to undertake a Traffic Impact Assessment (TIA) Study, to assess the traffic impact to be induced by the research and academic building within the Tuen Mun Campus of the Lingnan University to the nearby road network in the site vicinity.
- 6.1.2 In order to appraise the existing traffic condition in the area, comprehensive survey including classified turning movement counts, pedestrian count and public transport occupancy were carried out over the AM and PM peak periods on 27 June 2024. Assessment results indicate that the assessed junctions and link are currently operating at a satisfactory condition, while the pedestrian facilities are operating within capacity, and spare capacity of existing public transport services are generally identified.
- 6.1.3 The planned completion year for the proposed new building is 2028 and hence the “Design Year” for this study is set as 2031, i.e. 3 years after the completion year. Having reviewed the historical trend of traffic growth in the area and the forecast development intensity in the area, to provide conservative estimates, a growth factor of +1.79% per annum is adopted for estimating the 2031 Background Traffic Flows.
- 6.1.4 Traffic impact assessments are undertaken by comparing the peak hour junction performances of the 2031 Reference scenario against the Design scenario. Assessment results indicate that all the assessed junctions and links in the vicinity of the site would perform within capacity during the AM and PM peak periods for both scenarios, except for Yuen Long Highway with V/C between 1.0 and 1.2 (L2-1, L2-2) during PM peak time.
- 6.1.5 With the development traffic contribution onto the section of Yuen Long Highway is minimal (less than 5 veh/hr), we consider the development traffic impact onto Yuen Long Highway is trivial. **In long run, with highway infrastructures including Route 11 and Tuen Mun Bypass in place, traffic condition Yuen Long Highway will be significantly improved.**
- 6.1.6 Therefore, it can be concluded that the traffic generated by the proposed new building would not cause adverse traffic impact to the road network in the vicinity of the site.

- 6.1.7 Assessment on pedestrian flows and public transport services also indicate that the current pedestrian facilities and public transport services are sufficient to cater for the future pedestrian and public transport demand.

6.2 Conclusions

- 6.2.1 Based on the results of the traffic impact assessment study, it is concluded that the proposed new building would not induce adverse traffic impact on the road network in the vicinity of the site.

Figures

X:\Ozzo\82904_Consultancy Services for the New Research and Academic Building of Lingnan University\Data\Dwg\82904_Figure 2-1B.dwg 2024/11/22 18:32:58

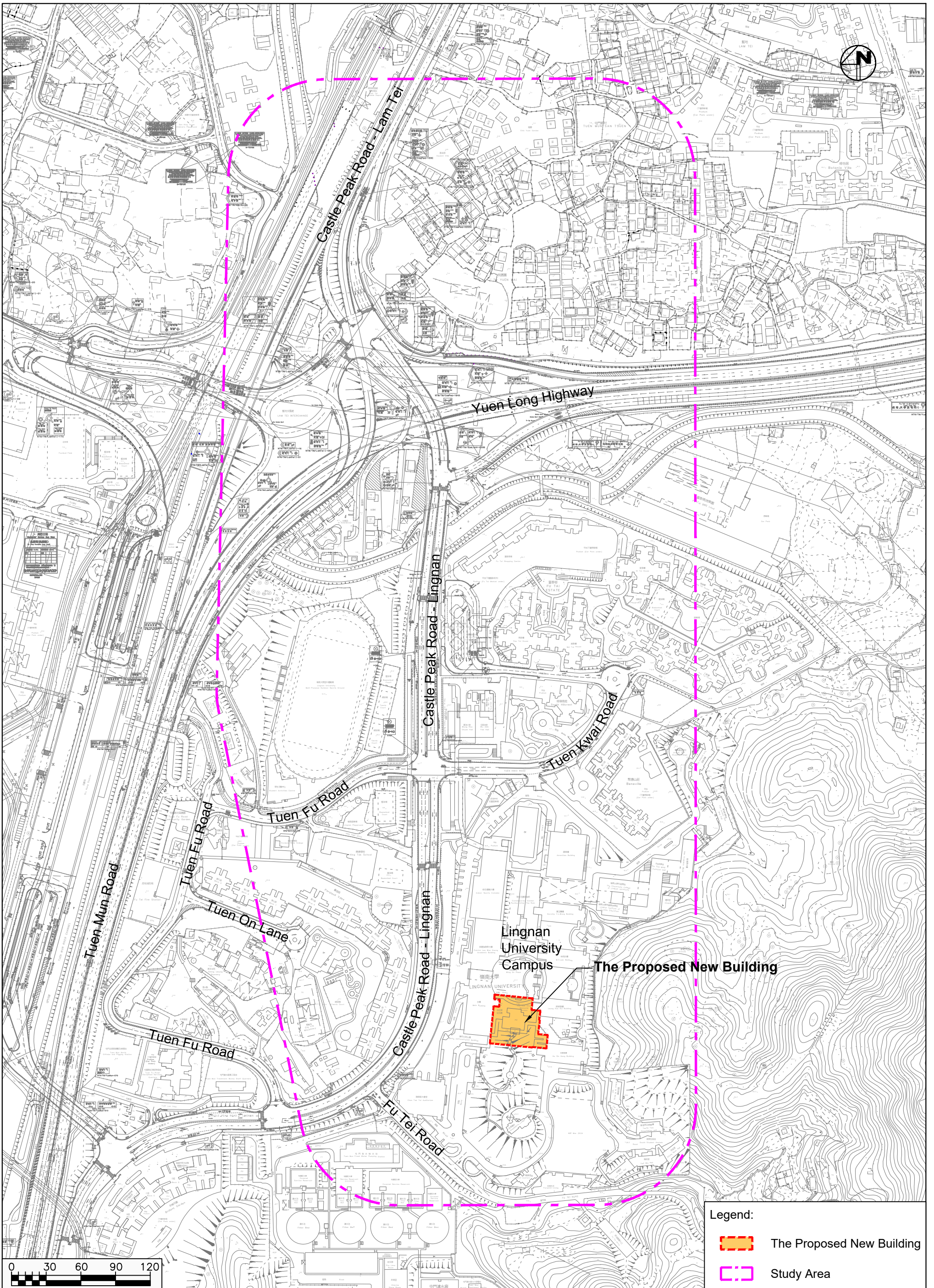

Legend:	
	The Proposed New Building
	Study Area

Date	Scale
22/11/2024	1:3000

**Proposed Minor Relaxation of Building Height Restriction for
the Permitted Educational Institution (New Science Building) in
"Government, Institution or Community" Zone at Lingnan University,
No. 8 Castle Peak Road - Lingnan, Tuen Mun**

Site Location and Study Area

Project No.	82904	Rev.	
Dwg No.	Figure 2-1		B

X:\Ozzo\82904_Consultancy Services for the New Research and Academic Building of Lingnan University\Data\82904_Figure 2-2B.dwg 2024/11/22 18:07:47

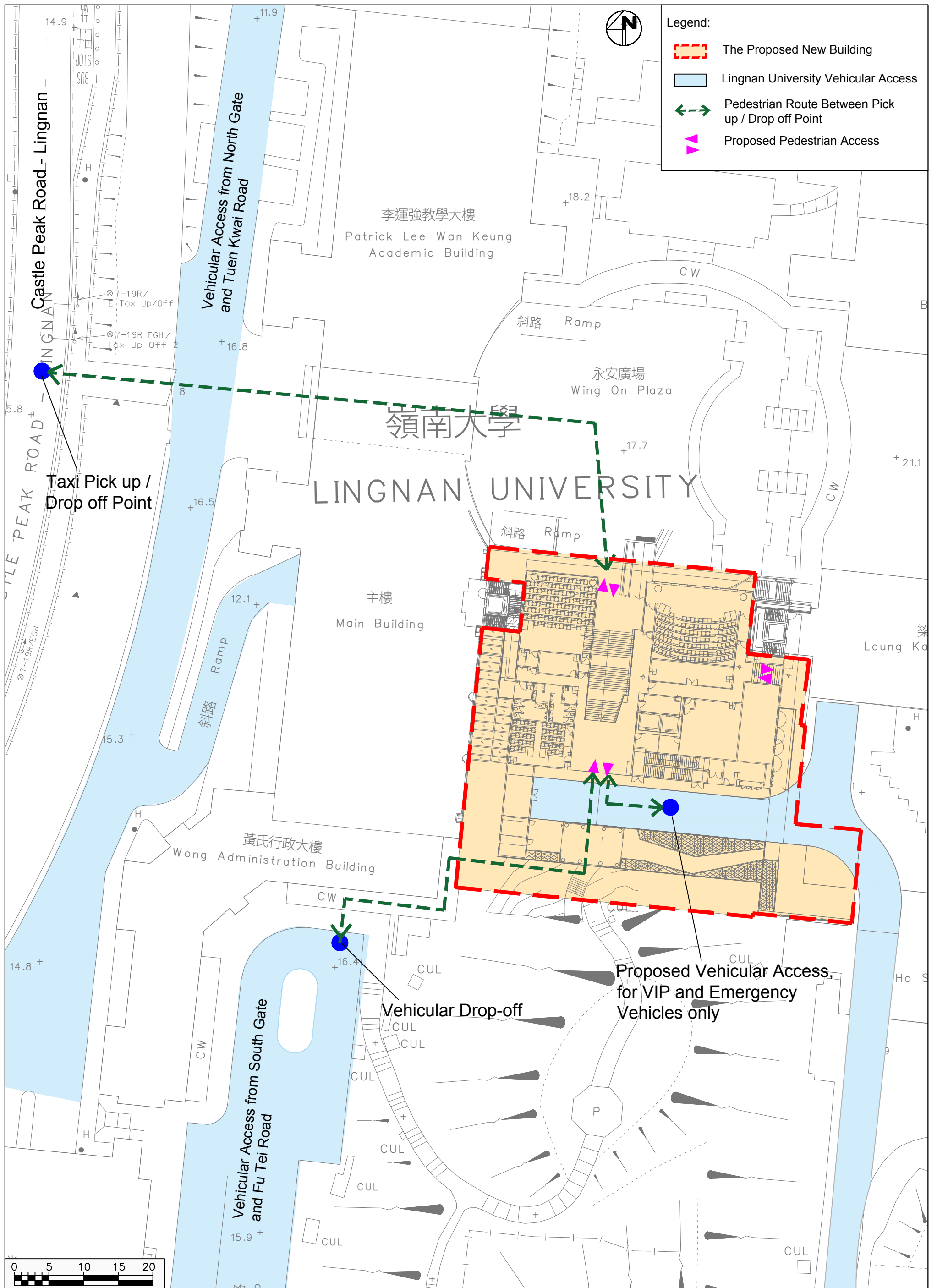

Legend:

- The Proposed New Building
- Lingnan University Vehicular Access
- ↔ Pedestrian Route Between Pick up / Drop off Point
- ▶ Proposed Pedestrian Access



Date
22/11/2024

Scale
1:500

**Proposed Minor Relaxation of Building Height Restriction for
the Permitted Educational Institution (New Science Building) in
"Government, Institution or Community" Zone at Lingnan University,
No. 8 Castle Peak Road - Lingnan, Tuen Mun**

**Proposed Vehicular and Pedestrian Access Arrangement
at Ground Floor**

Project No. 82904

Dwg No. Figure 2-2

Rev.

B

X:\Ozzo\82904_Consultancy Services for the New Research and Academic Building of Lingnan University\Data\Dwg\82904_Figure 3-1C.dwg 2025/01/08 09:57:41

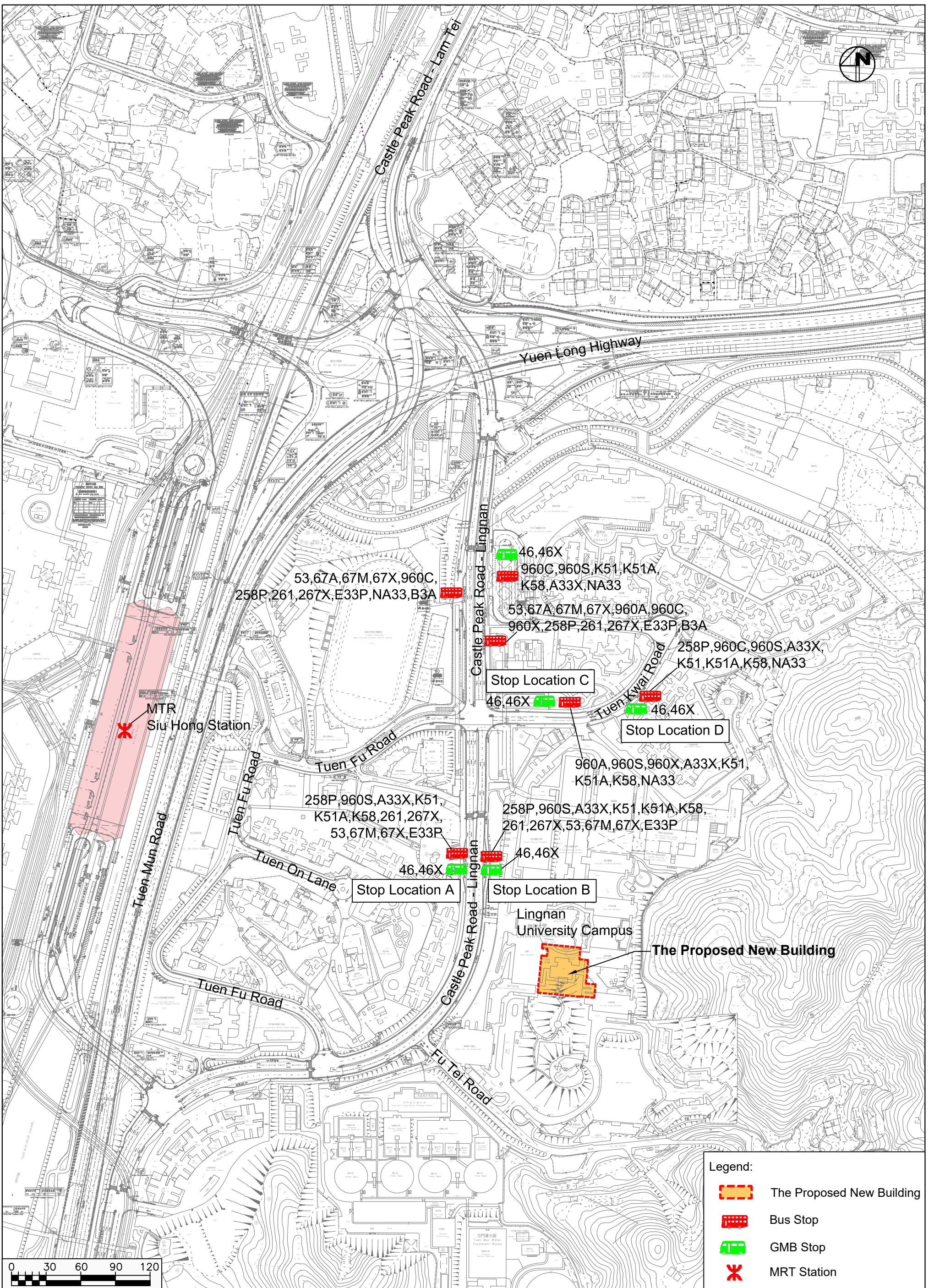

Legend:	
	The Proposed New Building
	Bus Stop
	GMB Stop
	MRT Station

Date 07/01/2025	Scale 1:3000

**Proposed Minor Relaxation of Building Height Restriction for
the Permitted Educational Institution (New Science Building) in
"Government, Institution or Community" Zone at Lingnan University,
No. 8 Castle Peak Road – Lingnan, Tuen Mun**

Existing Public Transport Inventory

Project No. 82904	Rev. C
Dwg No. Figure 3-1	

X:\Ozzo\82904_Consultancy Services for the New Research and Academic Building of Lingnan University\Data\Dwg\82904_Figure 3-2B.dwg 2024/11/22 18:10:01

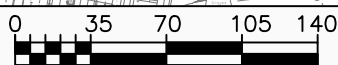
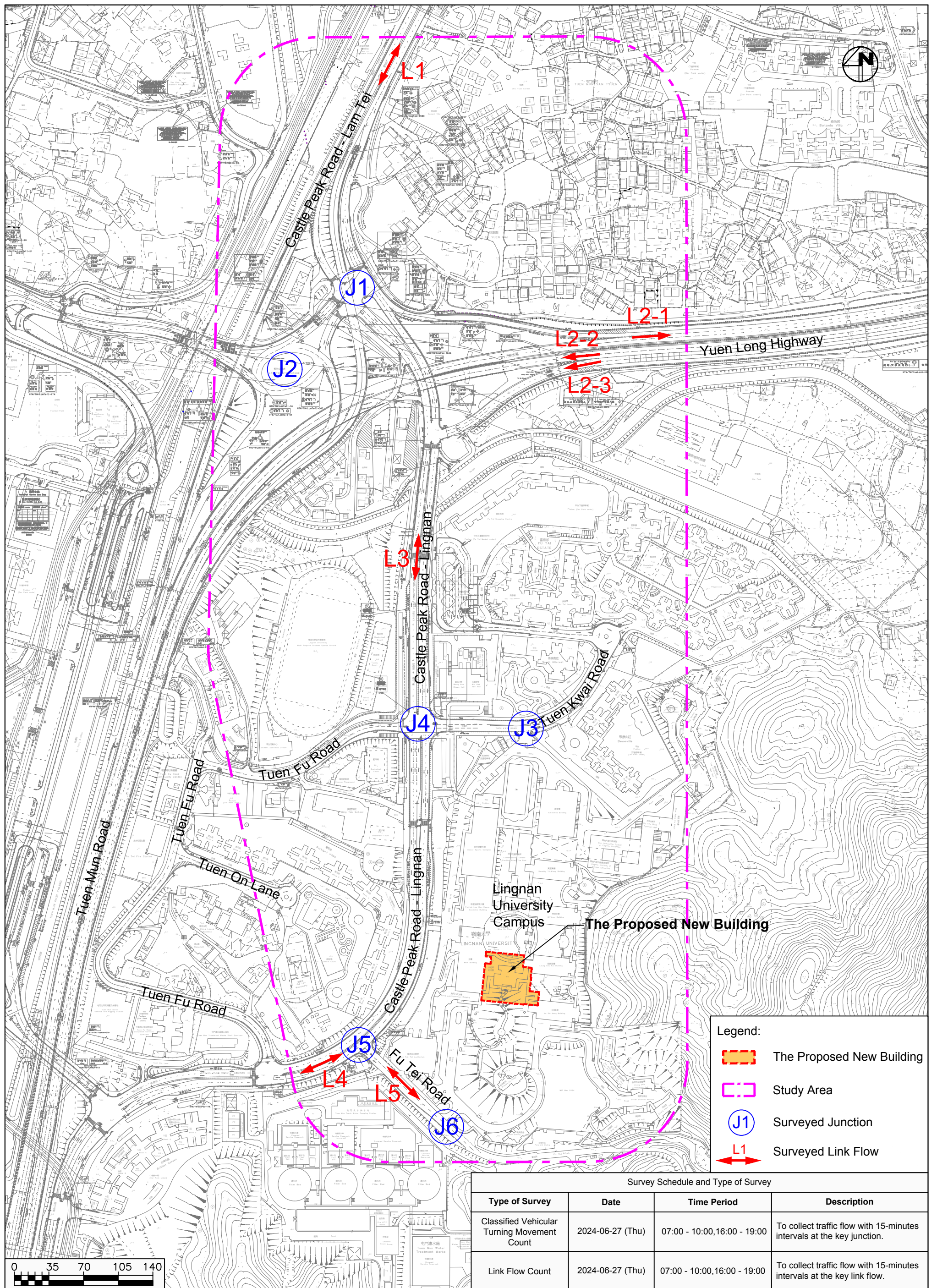

Date: 22/11/2024
Scale: 1:3500

Proposed Minor Relaxation of Building Height Restriction for the Permitted Educational Institution (New Science Building) in "Government, Institution or Community" Zone at Lingnan University, No. 8 Castle Peak Road – Lingnan, Tuen Mun

Locations of Survey (sheet 1 of 2)



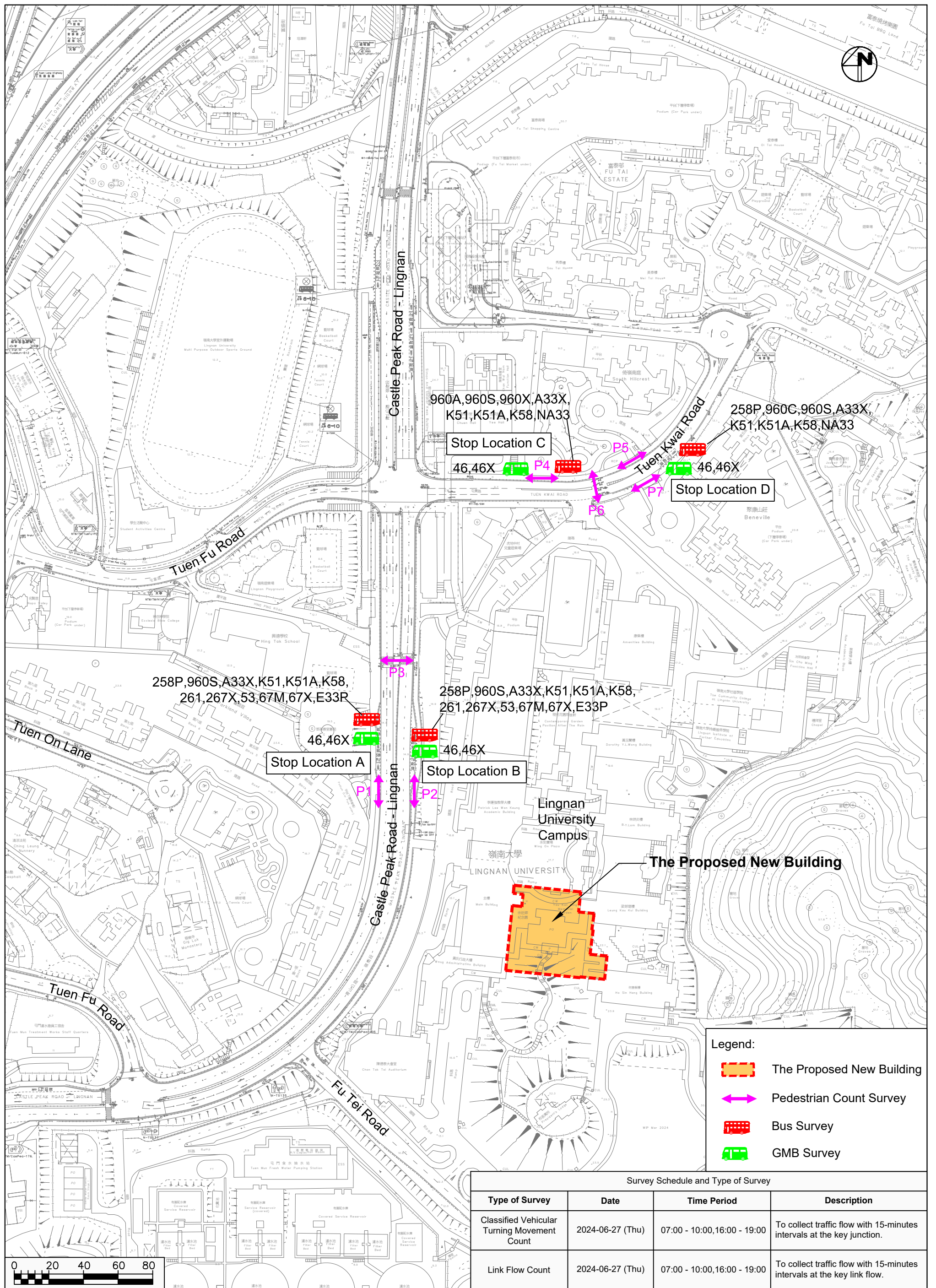

Project No. 82904
Dwg No. Figure 3-2

Rev. B

X:\Ozso\82904_Consultancy Services for the New Research and Academic Building of Lingnan University\Data\Dwg\82904_Figure 3-3C.dwg 2025/01/07 18:29:30



Legend:

-  The Proposed New Building
-  Pedestrian Count Survey
-  Bus Survey
-  GMB Survey

Survey Schedule and Type of Survey			
Type of Survey	Date	Time Period	Description
Classified Vehicular Turning Movement Count	2024-06-27 (Thu)	07:00 - 10:00, 16:00 - 19:00	To collect traffic flow with 15-minutes intervals at the key junction.
Link Flow Count	2024-06-27 (Thu)	07:00 - 10:00, 16:00 - 19:00	To collect traffic flow with 15-minutes intervals at the key link flow.



Date: 07/01/2025
Scale: 1:2000

Proposed Minor Relaxation of Building Height Restriction for the Permitted Educational Institution (New Science Building) in "Government, Institution or Community" Zone at Lingnan University, No. 8 Castle Peak Road - Lingnan, Tuen Mun

Locations of Survey (sheet 2 of 2)

Project No. 82904	Rev. C
Dwg No. Figure 3-3	

X:\Ozzo\82904_Consultancy Services for the New Research and Academic Building of Lingnan University\Data\Dwg\82904_Figure 3-4A.dwg 2025/01/07 16:32:56

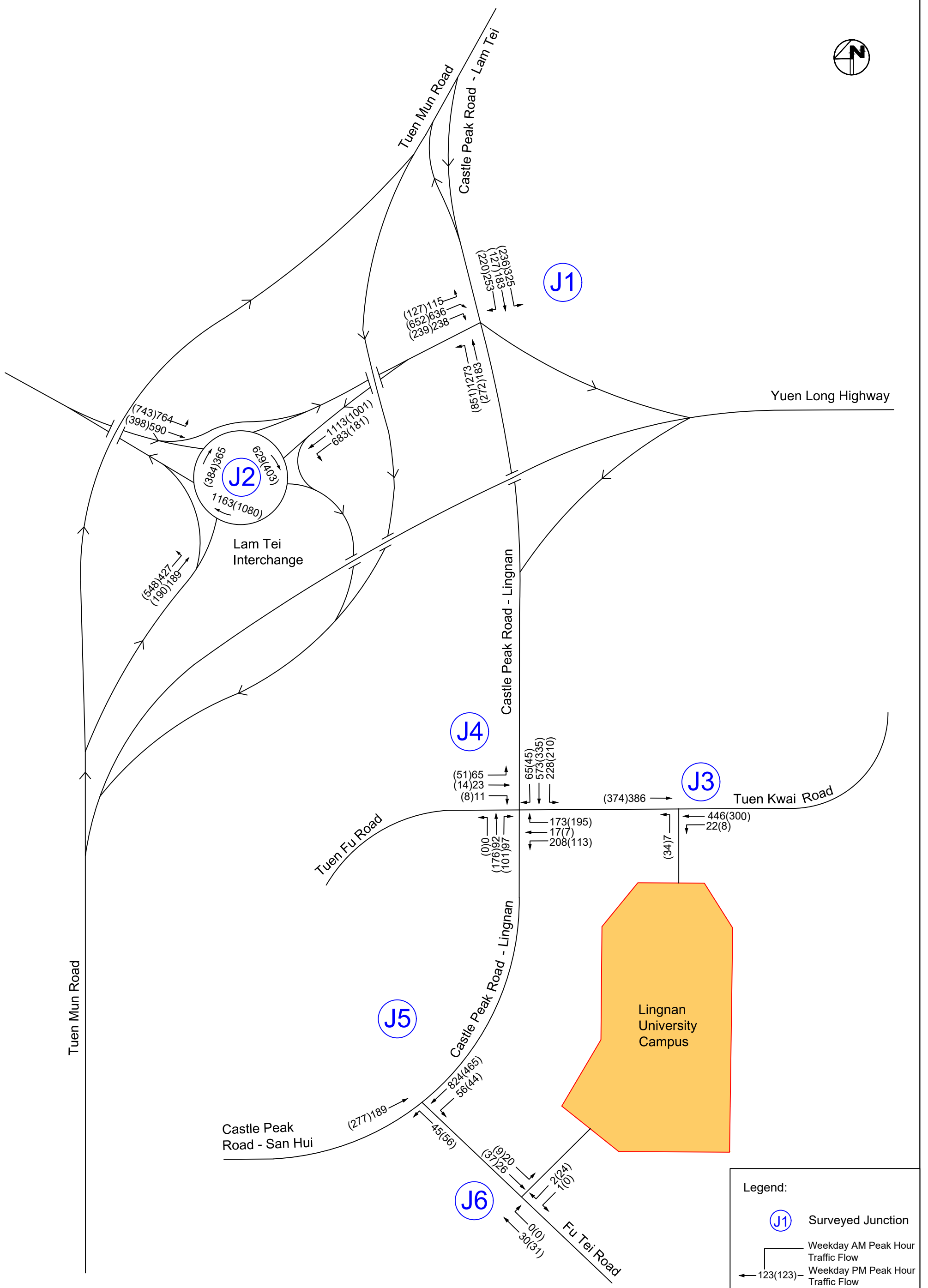

**Proposed Minor Relaxation of Building Height Restriction for
the Permitted Educational Institution (New Science Building) in
"Government, Institution or Community" Zone at Lingnan University,
No. 8 Castle Peak Road - Lingnan, Tuen Mun
2024 Observed Peak Hour Traffic Flows**

Date: 07/01/2025
Scale: NTS

Project No. 82904
Dwg No. Figure 3-4
Rev. A

X:\Ozzo\82904_Consultancy Services for the New Research and Academic Building of Lingnan University\Data\Dwg\82904_Figure 3-5A.dwg 2024/11/22 18:28:21

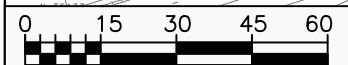
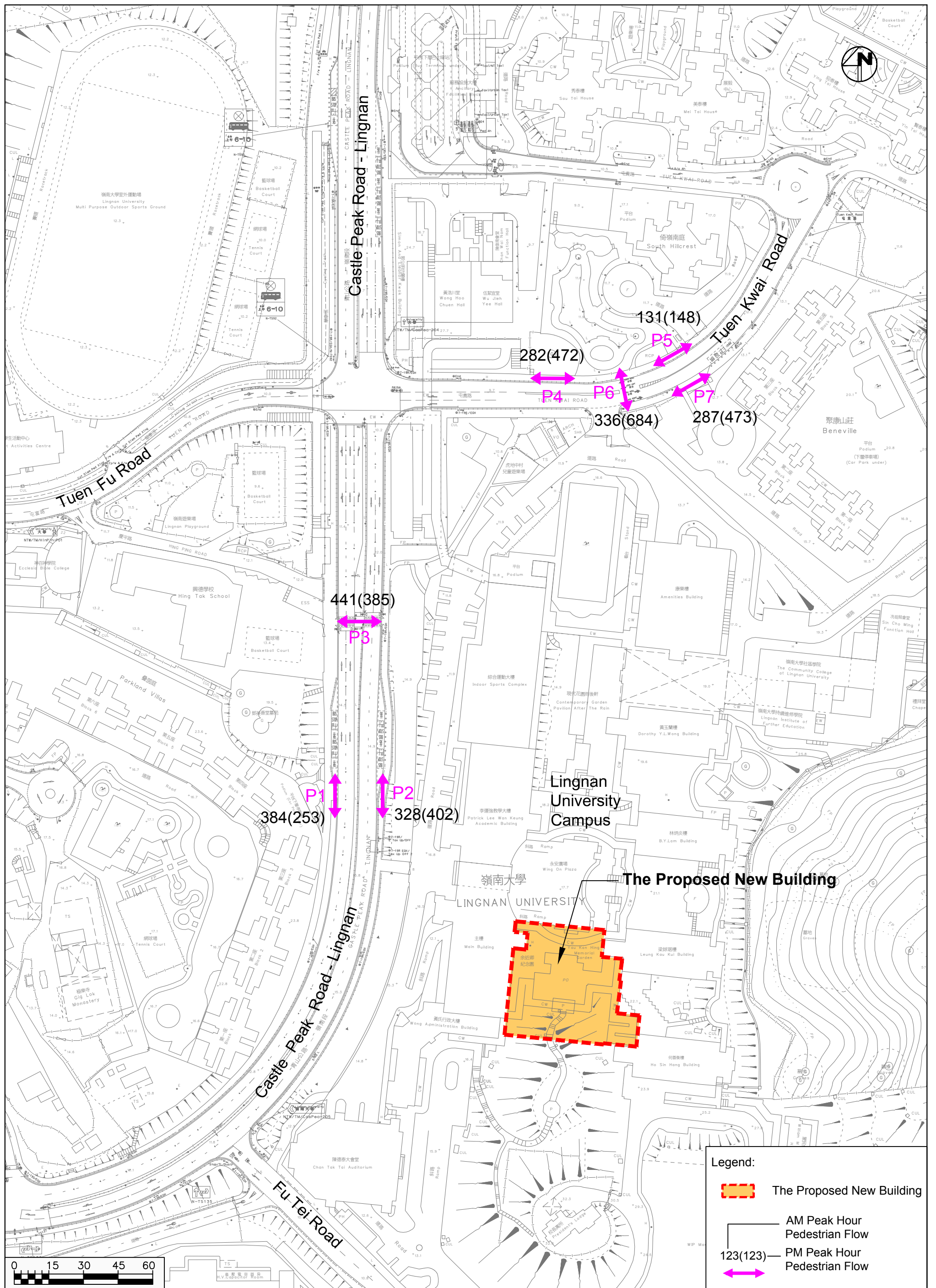

Proposed Minor Relaxation of Building Height Restriction for the Permitted Educational Institution (New Science Building) in "Government, Institution or Community" Zone at Lingnan University, No. 8 Castle Peak Road – Lingnan, Tuen Mun

2024 Observed Pedestrian Flows

Date	Scale
22/11/2024	1:1500

Project No.	82904	Rev.	B
Dwg No.	Figure 3-5		

X:\Ozzo\82904_Consultancy Services for the New Research and Academic Building of Lingnan University\Data\Dwg\82904_Figure 4-1A.dwg 2025/01/07 16:34:33

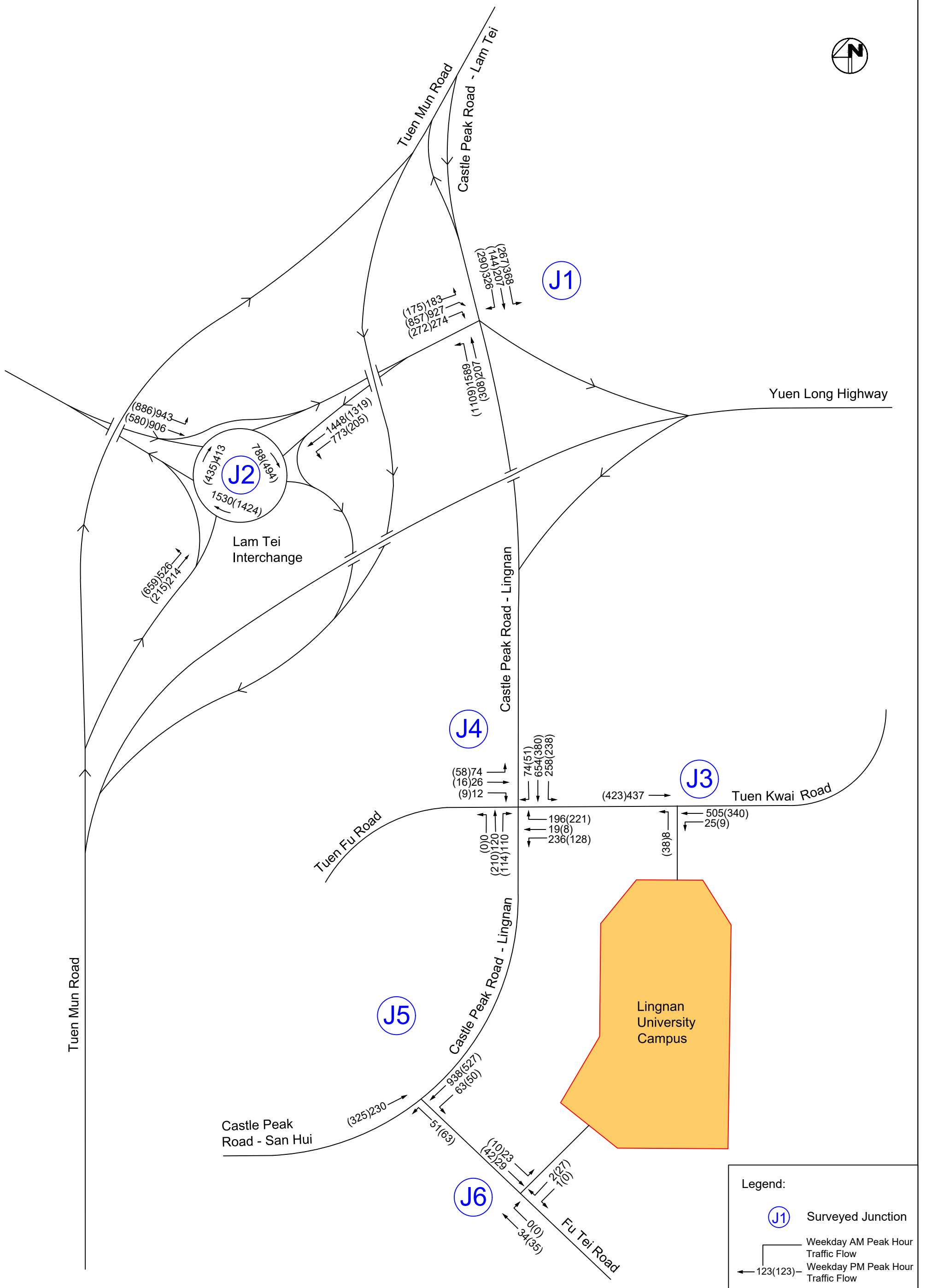

**Proposed Minor Relaxation of Building Height Restriction for
the Permitted Educational Institution (New Science Building) in
"Government, Institution or Community" Zone at Lingnan University,
No. 8 Castle Peak Road - Lingnan, Tuen Mun**
2031 Reference Peak Hour Traffic Flows

Date	Scale
07/01/2025	NTS

Project No.	82904	Rev.	A
Dwg No.	Figure 4-1		

X:\Ozzo\82904_Consultancy Services for the New Research and Academic Building of Lingnan University\Data\Dwg\82904_Figure 4-2A.dwg 2024/11/04 14:21:19

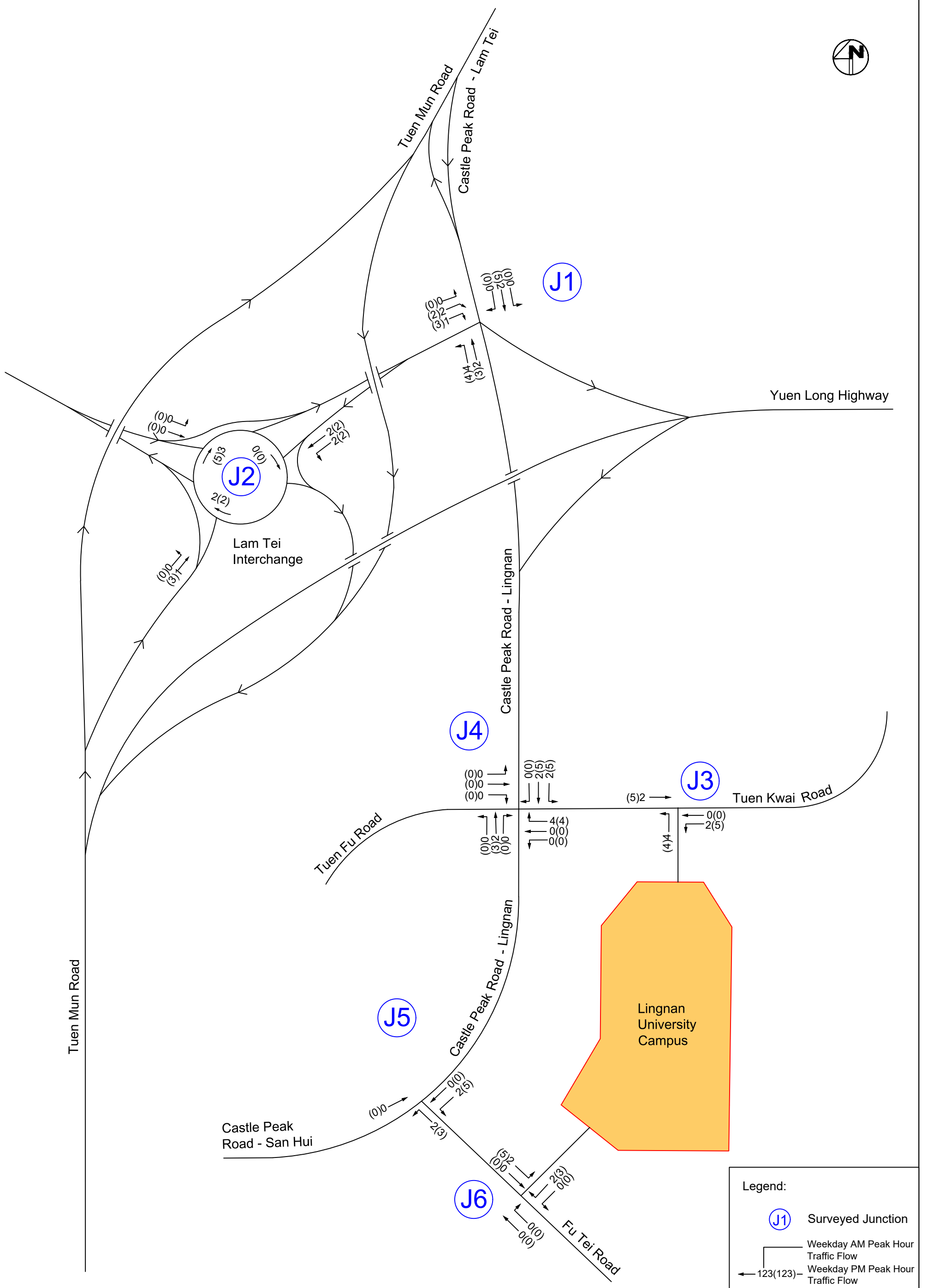

Legend:

- J1** Surveyed Junction
- Weekday AM Peak Hour Traffic Flow
- ← 123(123) Weekday PM Peak Hour Traffic Flow

OZZO TECHNOLOGY	
Date 04/11/2024	Scale NTS

Proposed Minor Relaxation of Building Height Restriction for the Permitted Educational Institution (New Science Building) in "Government, Institution or Community" Zone at Lingnan University, No. 8 Castle Peak Road - Lingnan, Tuen Mun

Peak Hour Development Traffic Flows

Project No. 82904	Rev. A
Dwg No. Figure 4-2	

X:\Ozzo\82904_Consultancy Services for the New Research and Academic Building of Lingnan University\Data\Dwg\82904_Figure 4-3B.dwg 2025/01/07 16:35:59

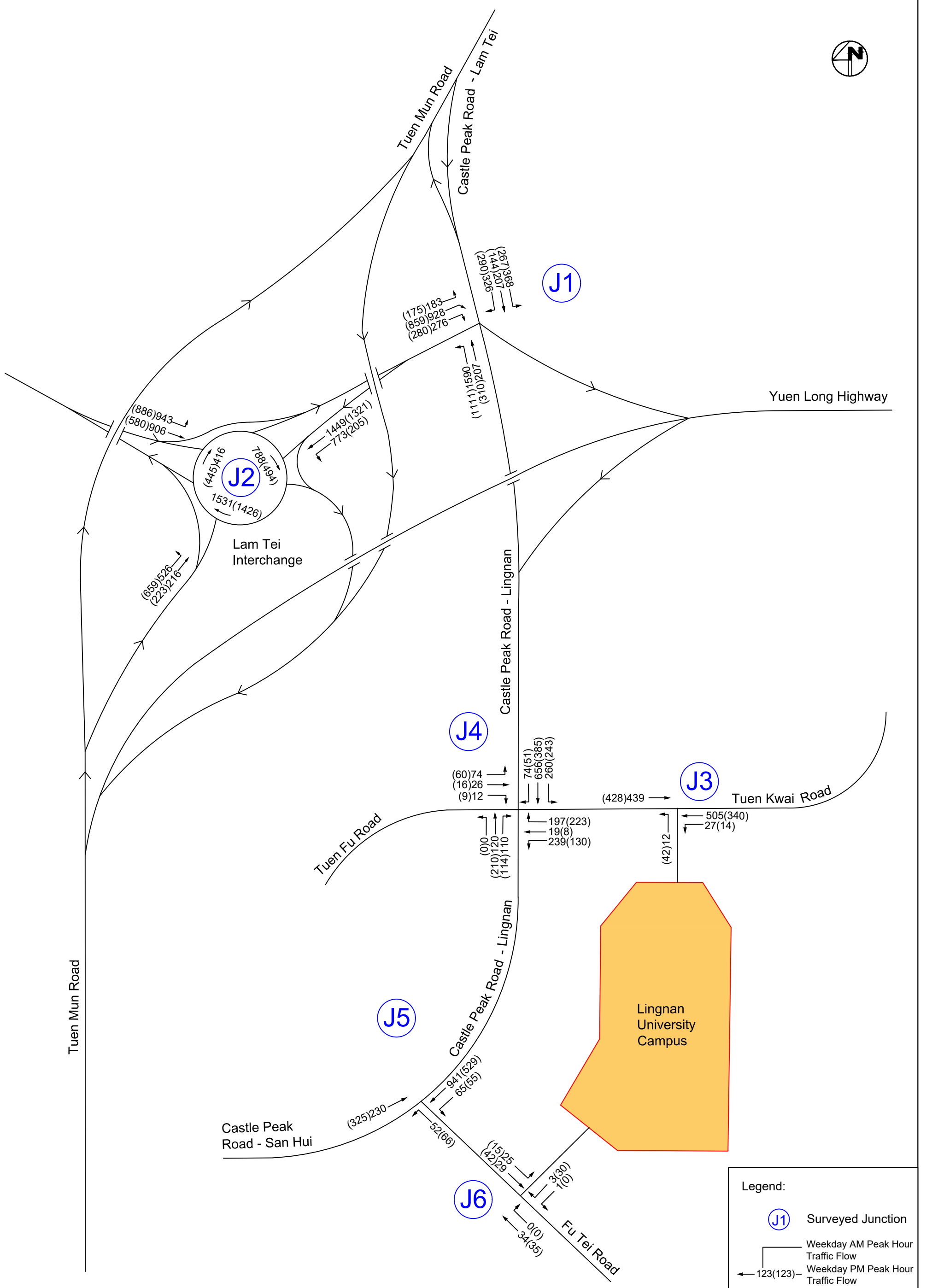

Proposed Minor Relaxation of Building Height Restriction for the Permitted Educational Institution (New Science Building) in "Government, Institution or Community" Zone at Lingnan University, No. 8 Castle Peak Road - Lingnan, Tuen Mun

Date: 07/01/2025
Scale: NTS

2031 Design Peak Hour Traffic Flows

Project No. 82904
Dwg No. Figure 4-3
Rev. B

X:\Ozzo\82904_Consultancy Services for the New Research and Academic Building of Lingnan University\Data\Dwg\82904_Figure 5-1B.dwg 2024/11/22 18:11:39

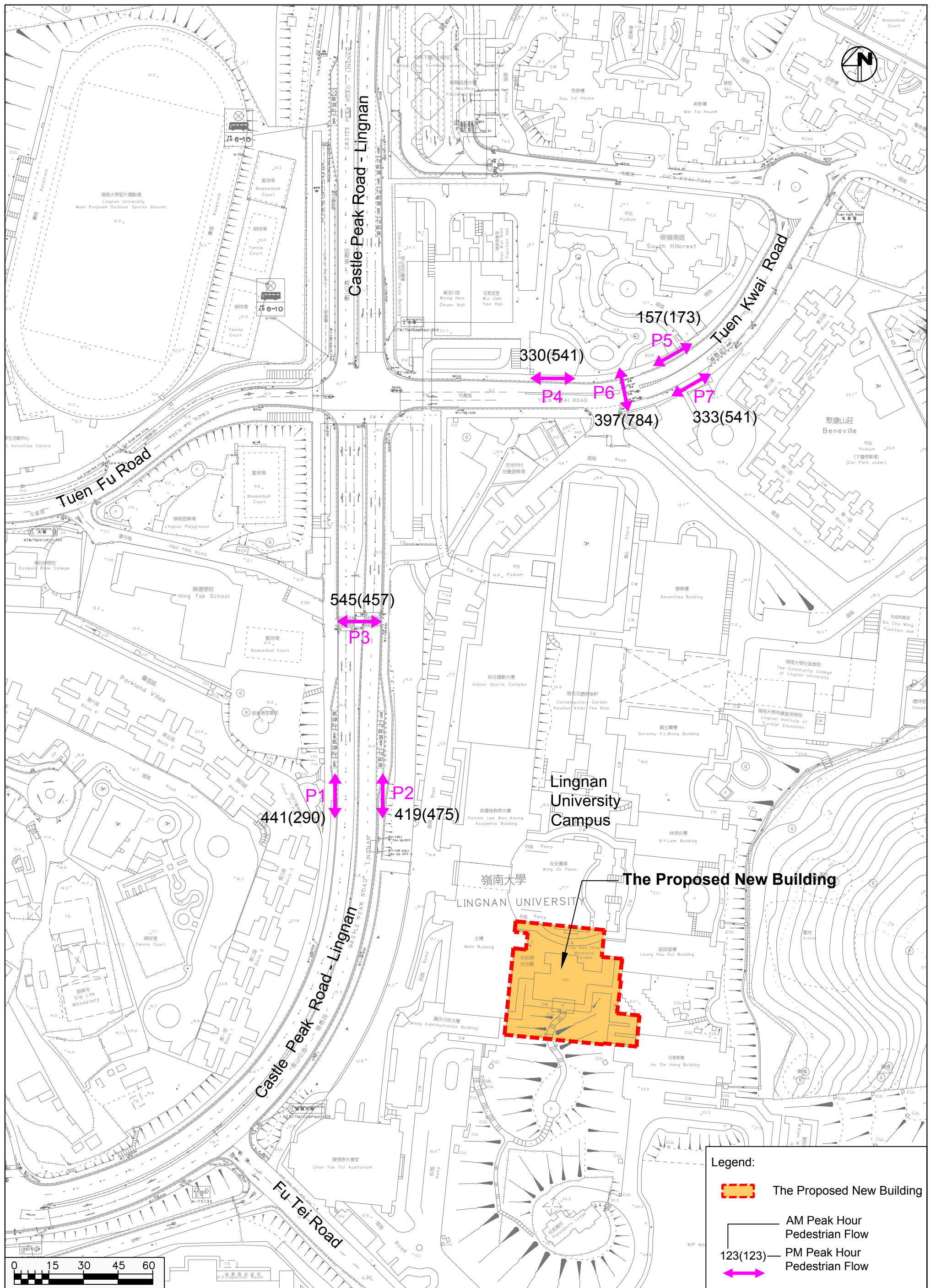

Legend:

- The Proposed New Building
- AM Peak Hour Pedestrian Flow
- PM Peak Hour Pedestrian Flow

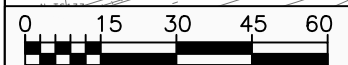

OZZO TECHNOLOGY	
Date 22/11/2024	Scale 1:1500

Proposed Minor Relaxation of Building Height Restriction for the Permitted Educational Institution (New Science Building) in "Government, Institution or Community" Zone at Lingnan University, No. 8 Castle Peak Road – Lingnan, Tuen Mun

2031 Design Scenario Pedestrian Flows

Project No. 82904	Rev. B
Dwg No. Figure 5-1	

Annex A

Swept Path Assessment Results

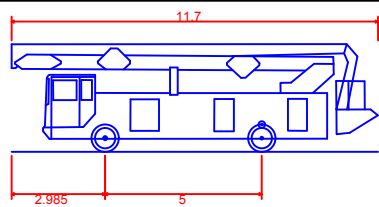

Larger Fire Appliance
 Overall Length 11.700m
 Overall Width 2.490m
 Overall Body Height 3.439m
 Min Body Ground Clearance 0.416m
 Track Width 2.490m
 Lock to Lock Time 4.00 sec
 Kerb to Kerb Turning Radius 10.500m

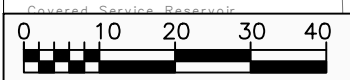
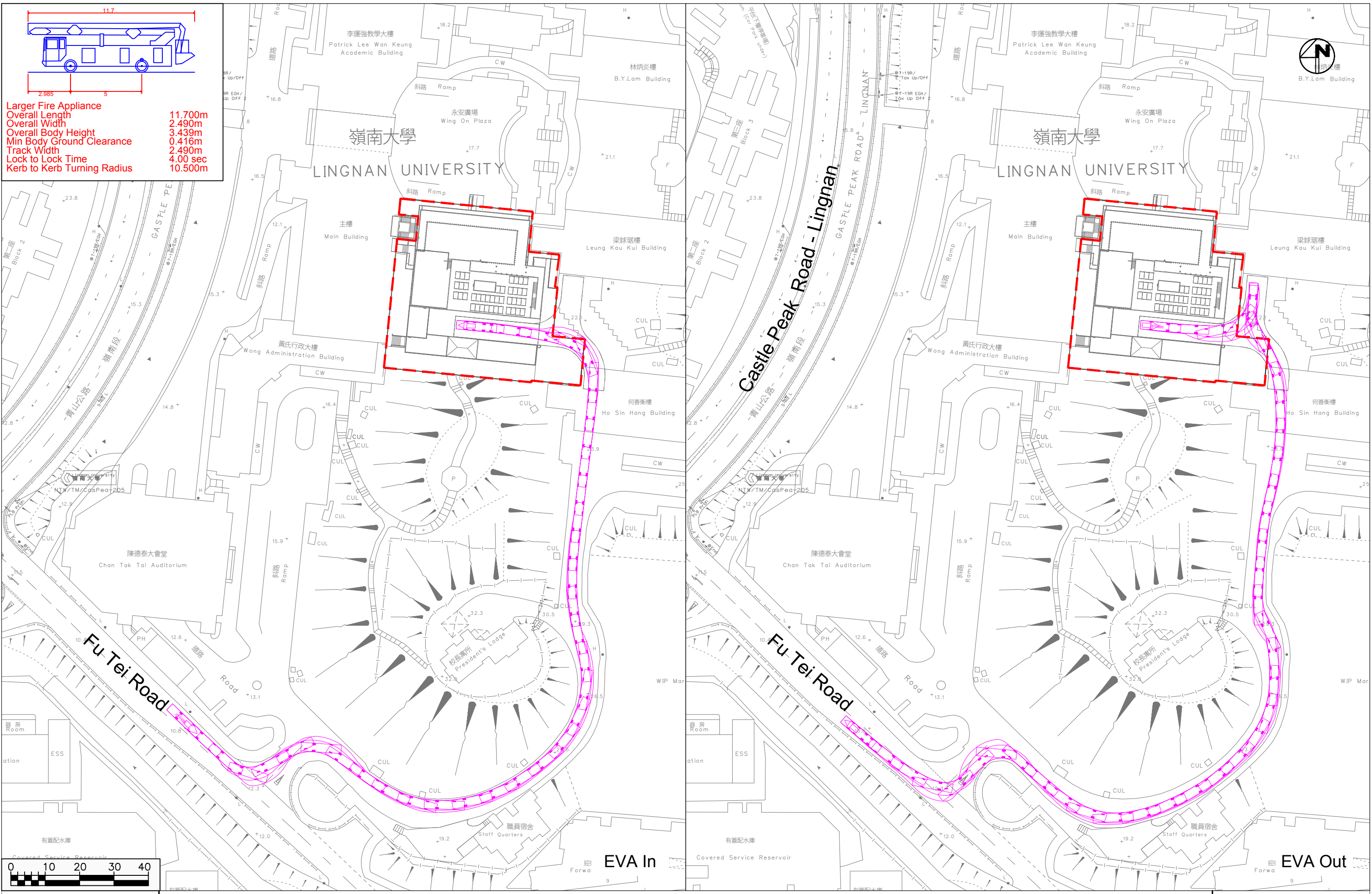

**Proposed Minor Relaxation of Building Height Restriction for the Permitted Educational Institution (New Science Building) in
 “Government, Institution or Community” Zone at Lingnan University, No. 8 Castle Peak Road – Lingnan, Tuen Mun**

Swept Path Analysis for the Newly Proposed EVA

Date 22/11/2024
 Scale 1:1000

Dwg No. Annex A
 Rev. B

X:\Ozzo\82904_Consultancy Services for the New Research and Academic Building of Lingnan University\Data\Dwg\82904_Annex A_20241122.dwg 2024/11/22 18:15:30

Annex B

Layout of Junctions

X:\02z0182904_Consultancy Services for the New Research and Academic Building of Lingnan University\Data\DWG\82904_Annex B.dwg 2024/11/06 14:48:12

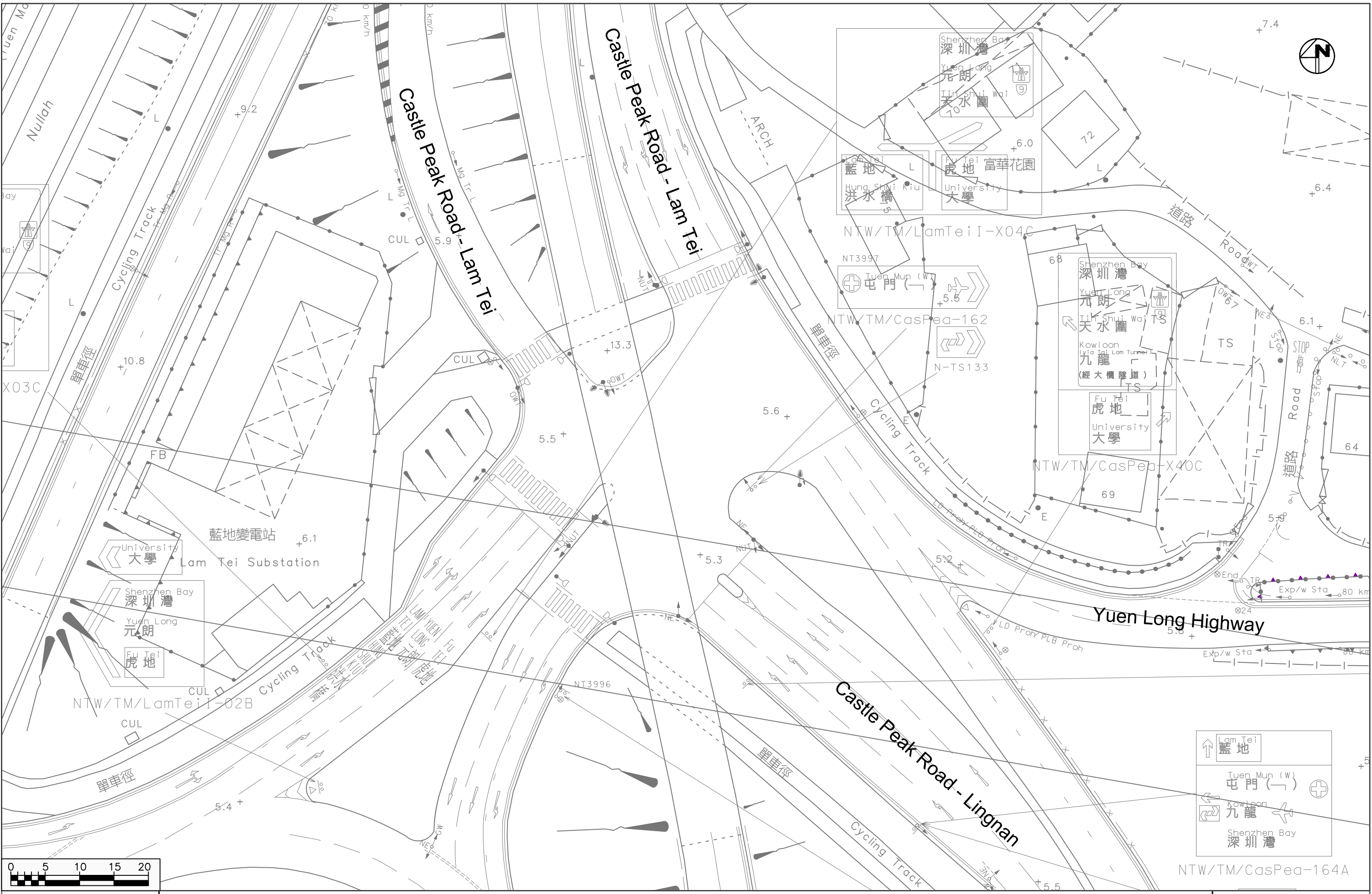

**Proposed Minor Relaxation of Building Height Restriction for the Permitted Educational Institution (New Science Building) in
 "Government, Institution or Community" Zone at Lingnan University, No. 8 Castle Peak Road – Lingnan, Tuen Mun
 Junction of Castle Peak Road - Lam Tei / Castle Peak Road - Lingnan (J1)**



Dwg No. Annex B-1	Rev. -
----------------------	-----------

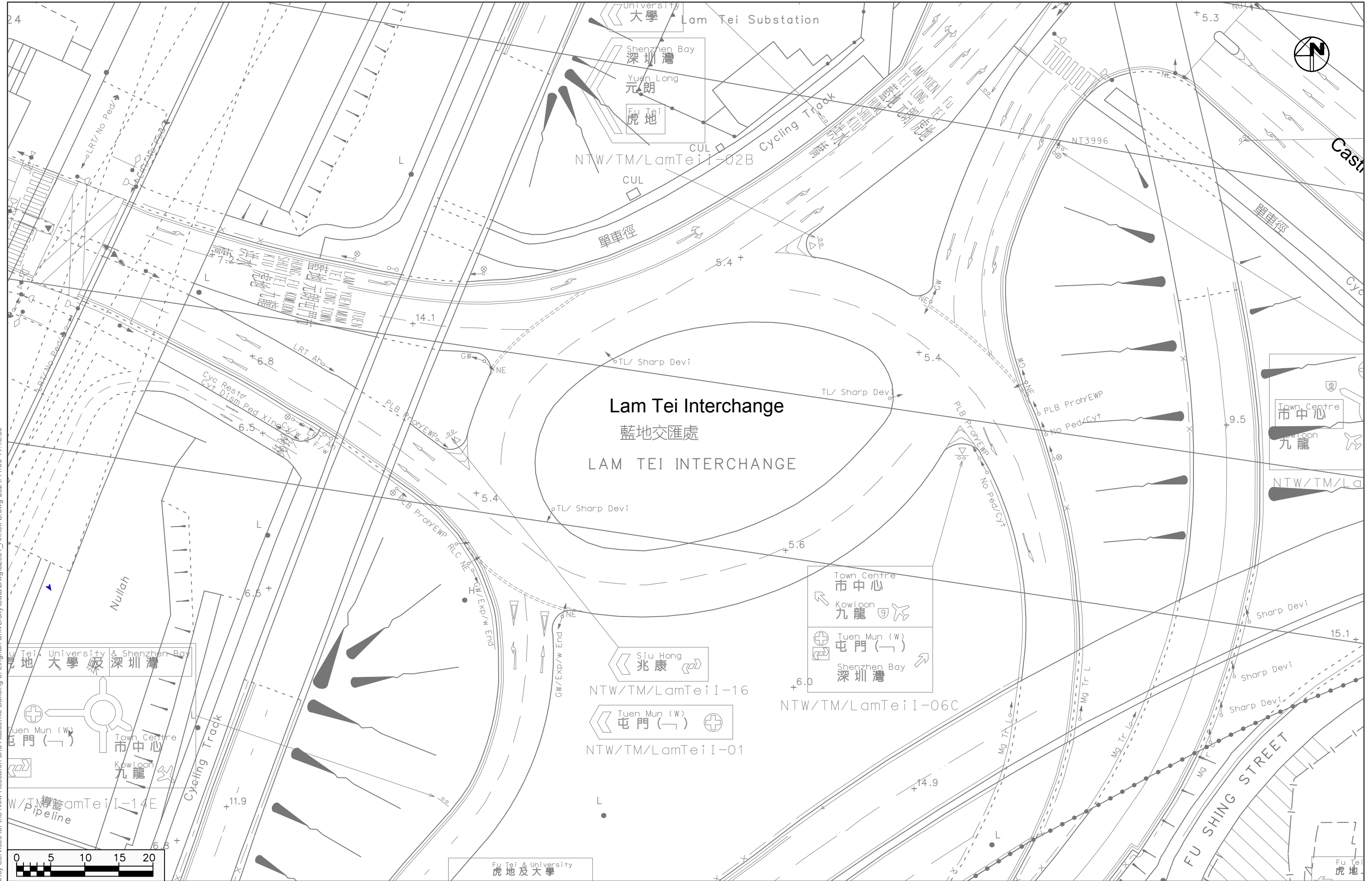

**Proposed Minor Relaxation of Building Height Restriction for the Permitted Educational Institution (New Science Building) in
“Government, Institution or Community” Zone at Lingnan University, No. 8 Castle Peak Road – Lingnan, Tuen Mun**

Lam Tei Interchange (J2)



Date	Scale
06/11/2024	1:500

Dwg No.	Rev.
Annex B-2	-

X:\02z0182904_Consultancy Services for the New Research and Academic Building of Lingnan University\Data\Dwg\82904_Annex B.dwg 2024/11/06 14:48:50

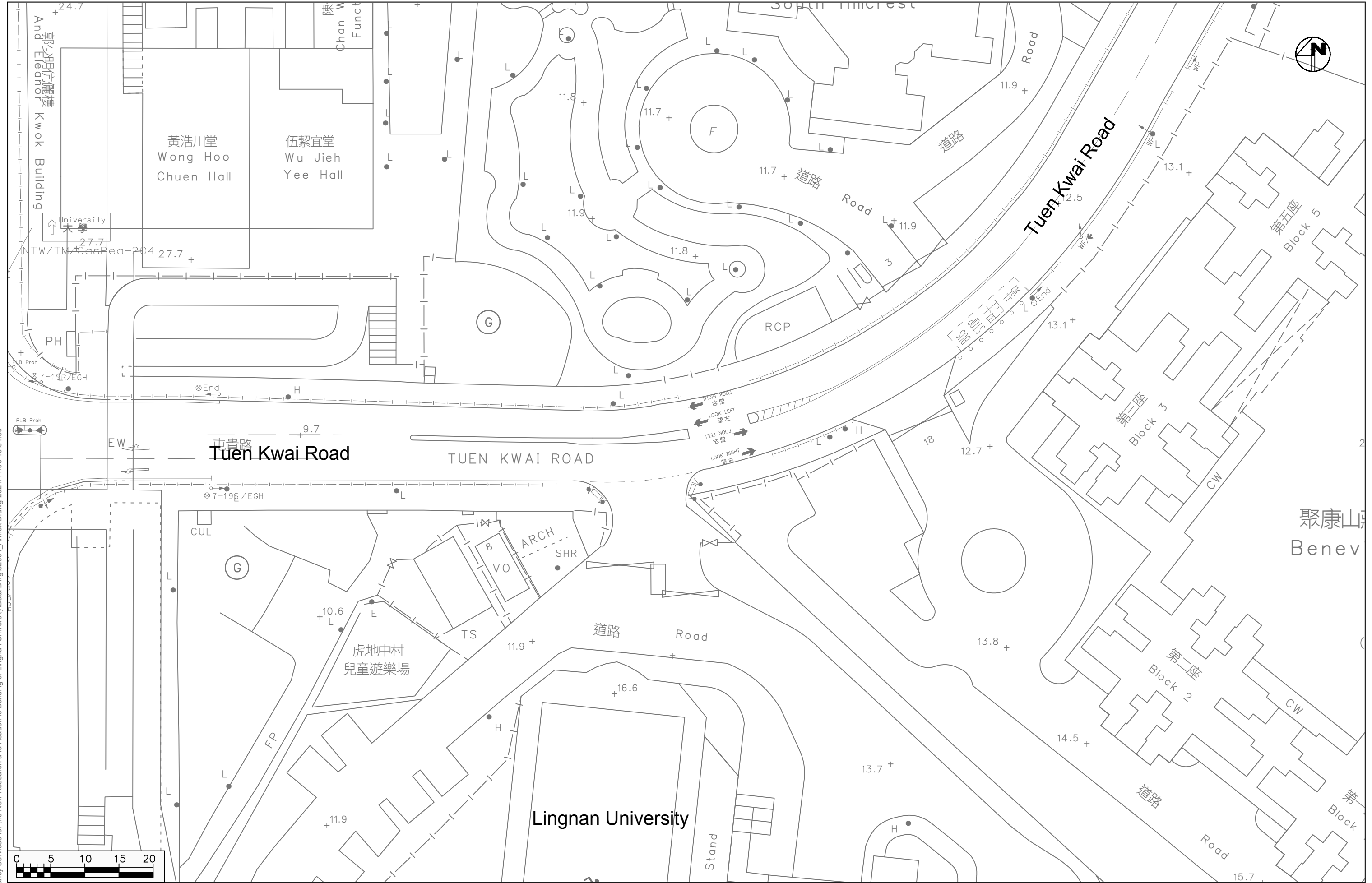

Proposed Minor Relaxation of Building Height Restriction for the Permitted Educational Institution (New Science Building) in “Government, Institution or Community” Zone at Lingnan University, No. 8 Castle Peak Road – Lingnan, Tuen Mun

Junction of Tuen Kwai Road / Northern Access of Lingnan University (J3)



Date: 06/11/2024
Scale: 1:500

Dwg No. Annex B-3
Rev. -

X:\020182904_ Consultancy Services for the New Research and Academic Building of Lingnan University\Data\Dwg\82904_Annex B.dwg 2024/11/06 15:31:50

X:\02082904_Consultancy Services for the New Research and Academic Building of Lingnan University\Data\Dwg\82904_Annex B.dwg 2024/11/06 14:49:30

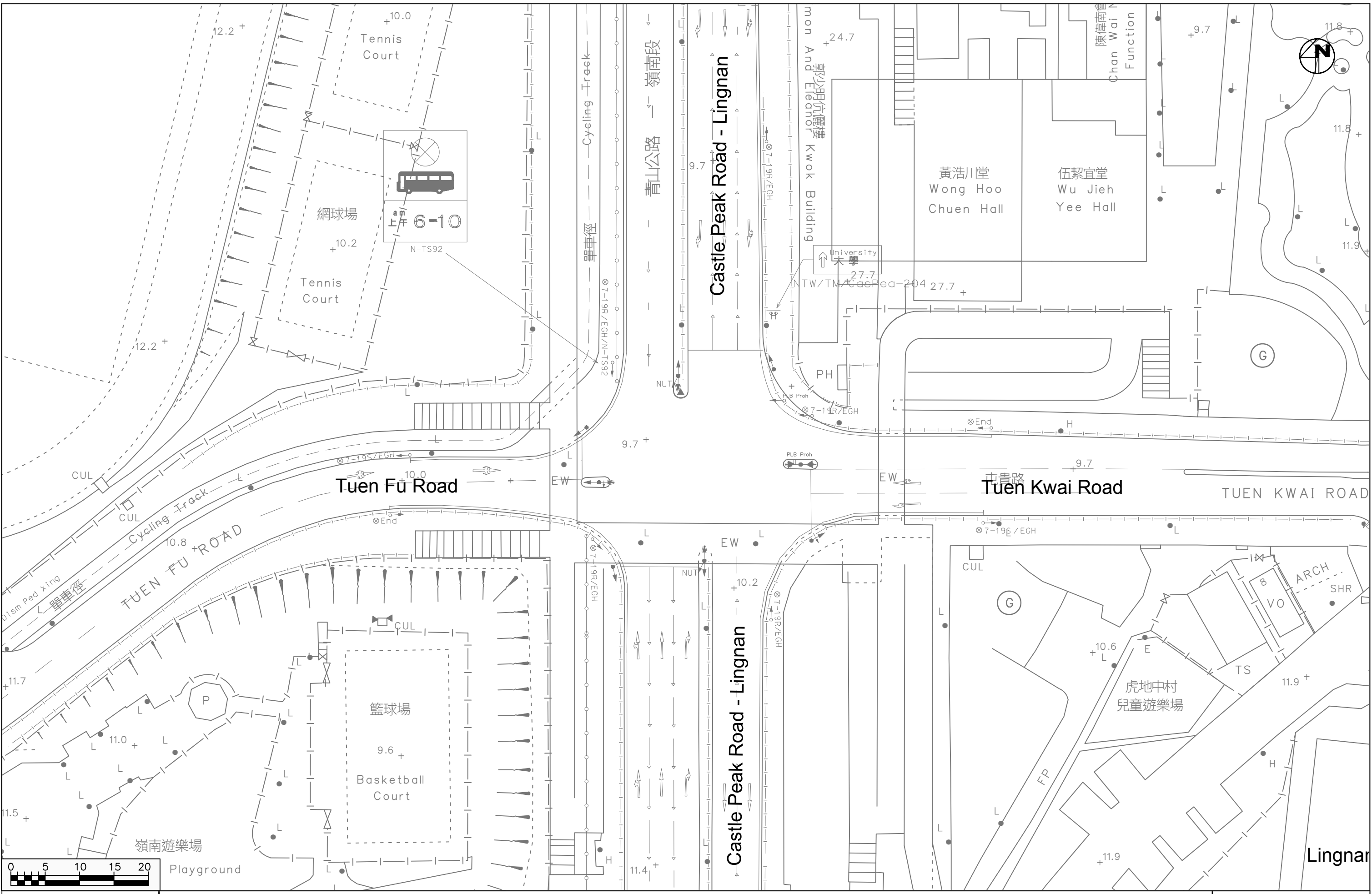

Proposed Minor Relaxation of Building Height Restriction for the Permitted Educational Institution (New Science Building) in "Government, Institution or Community" Zone at Lingnan University, No. 8 Castle Peak Road - Lingnan, Tuen Mun

Junction of Castle Peak Road - Lingnan / Tuen Fu Road / Tuen Kwai Road (J4)



Date	Scale
06/11/2024	1:500

Dwg No.	Rev.
Annex B-4	-

X:\02082904_Consultancy Services for the New Research and Academic Building of Lingnan University\Data\DWG\82904_Annex B.dwg 2024/11/06 14:49:55

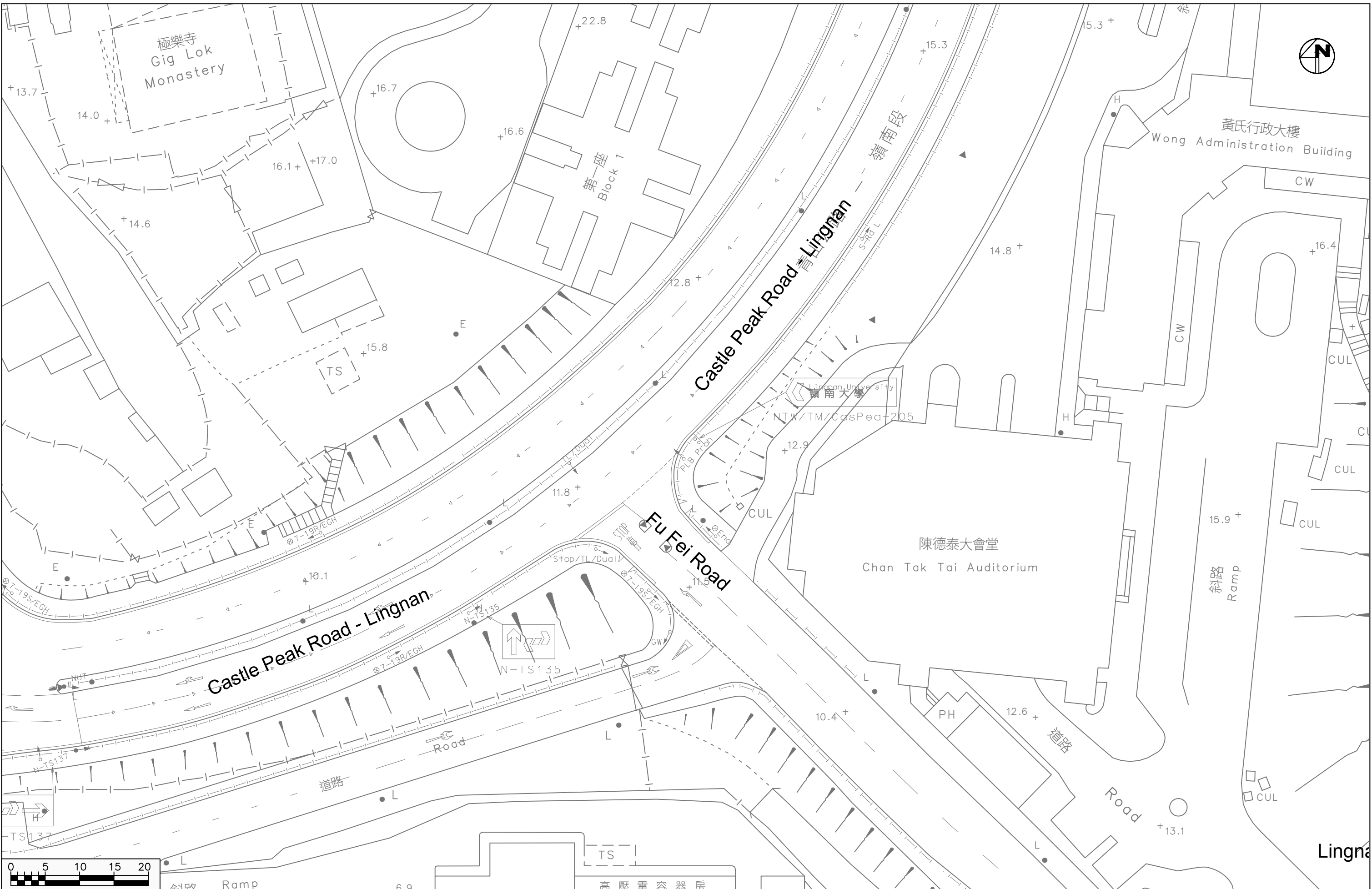

**Proposed Minor Relaxation of Building Height Restriction for the Permitted Educational Institution (New Science Building) in
 “Government, Institution or Community” Zone at Lingnan University, No. 8 Castle Peak Road – Lingnan, Tuen Mun
 Junction of Castle Peak Road - Lingnan / Fu Tei Road (J5)**

Date	Scale
06/11/2024	1:500

OZZO TECHNOLOGY	
Dwg No.	Rev.
Annex B-5	-

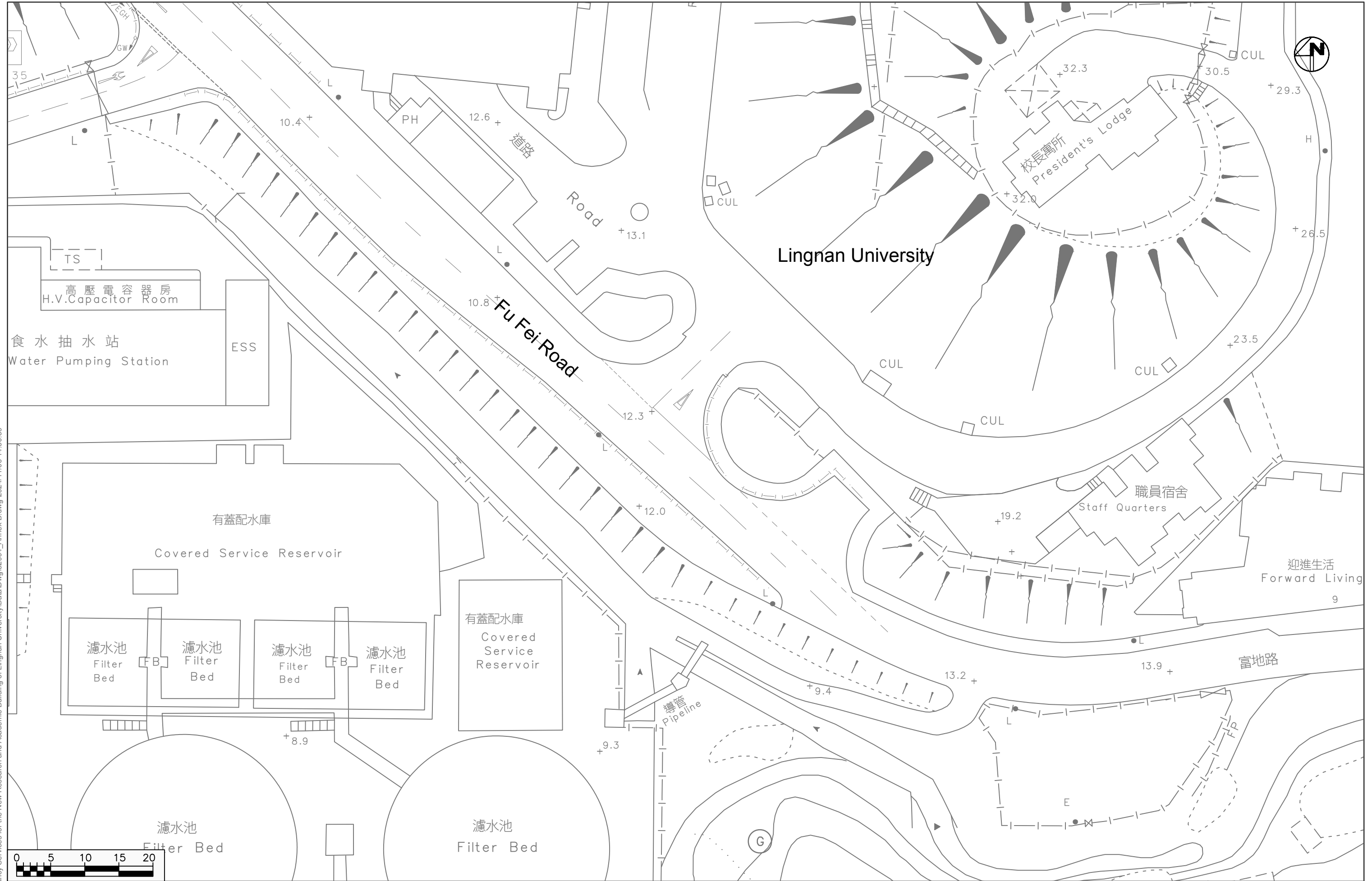

Proposed Minor Relaxation of Building Height Restriction for the Permitted Educational Institution (New Science Building) in “Government, Institution or Community” Zone at Lingnan University, No. 8 Castle Peak Road – Lingnan, Tuen Mun

Junction of Fu Tei Road / Southern Access of Lingnan University (J6)



Date: 06/11/2024
Scale: 1:500

Dwg No.: Annex B-6
Rev.: -

X:\OZZO\82904_Consultancy Services for the New Research and Academic Building of Lingnan University\Data\DWG\82904_Annex B.dwg 2024/11/06 14:50:59

Annex C

2024 Junction Calculation Sheets

OZZO TECHNOLOGY (HK) LIMITED

TRAFFIC SIGNAL CALCULATION

INITIALS DATE

Proposed Minor Relaxation of Building Height Restriction for the Permitted Educational Institution (New Science Building) in "Government, Institution or Community" Zone at Lingnan University, No. 8 Castle Peak Road - Lingnan, Tuen Mun

PROJECT NO. 82904

Prepared By: LL

Jan-25

J1: Castle Peak Road - Lingnan / Castle Peak Road - Lam Tei

2024 AM

FILENAME :

Checked By: DP

Jan-25

2024 Observed AM Peak Hour Traffic Flows

e Peak Road - Lam Tei_Castle Peak Road - Lingnan_S.xls

Reviewed By: OC

Jan-25

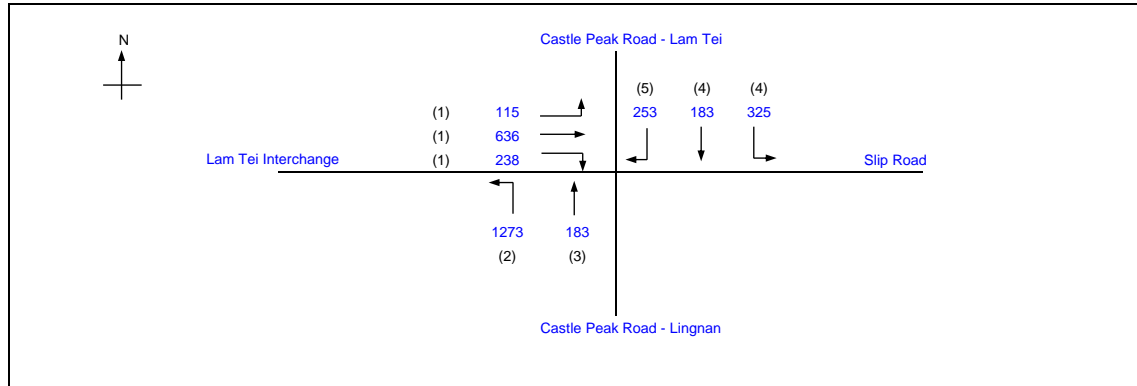

		Existing Cycle Time	
No. of stages per cycle	N =	3	
Cycle time	C =	110 sec	
Sum(y)	Y =	0.410	
Loss time	L =	17 sec	
Total Flow	=	3206 pcu	
Co = (1.5*L+5)/(1-Y)	=	51.7 sec	
Cm = L/(1-Y)	=	28.8 sec	
Yult	=	0.773	
R.C.ult = (Yult-Y)/Y*100%	=	88.4 %	
Cp = 0.9*L/(0.9-Y)	=	31.2 sec	
Ymax = 1-L/C	=	0.845	
R.C.(C) = (0.9*Ymax-Y)/Y*100%	=	85.6 %	

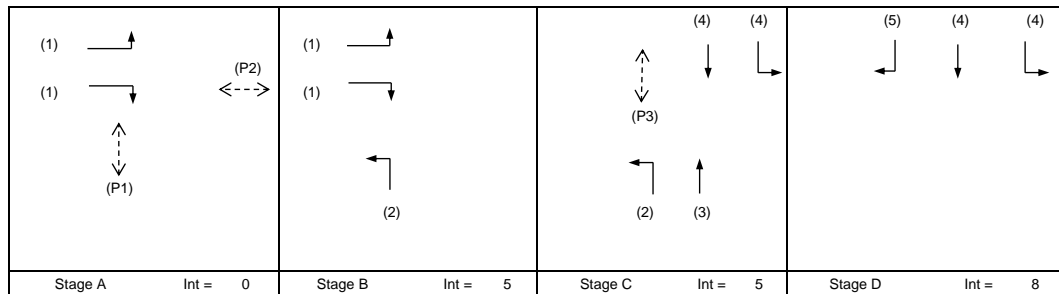

Pedestrian Phase	Stage	Length (m)	Green Time Required (s)			Green Time Provided (s)	
			SG	FG	Delay	SG	FG
P1	A	7	5	6	2	60	12
P2	A	7	5	6	14	26	16
P3	C	14	5	12	2	99	8

Movement	Stage	Lane Width m.	Phase	No. of lane	Radius m.	O	N	Straight-Ahead Sat. Flow	Movement			Total FLOW pcu/h	Proportion of Turning Vehicles	Sat. Flow pcu/h	Flare lane Length m.	Share Effect pcu/hr	Revised Sat. Flow pcu/h	y	Greater y	L sec	g (required) sec	g (input) sec	Degree of Saturation X	Queue Length (m / lane)	Average Delay (seconds)
									Left pcu/h	Straight pcu/h	Right pcu/h														
LT	A,B	3.40	1	1	15		N	1955	115		115	1.00	1777			1777	0.065		17	15	80	0.089	0	4	
LT,RT	A,B	3.30	1	1	34		N	2085	0	330	330	1.00	1997			1997	0.165			37	80	0.227	12	5	
RT	A,B	3.30	1	1	31		N	1945		306	306	1.00	1855			1855	0.165			37	80	0.227	12	5	
RT	A,B	3.30	1	1	31		N	1945		238	238	1.00	1855			1855	0.128			29	80	0.176	0	0	
LT	B,C	3.30	2	2	14			4170	1273		1273	1.00	3766			3766	0.338	0.338		77	53	0.701	60	22	
SA	C	3.30	3	2				4170		183	183	0.00	4170			4170	0.044			10	31	0.156	12	27	
LT	C,D	3.30	4	1	100		N	1945	325		325	1.00	1916			1916	0.170			38	47	0.397	30	21	
SA	C,D	3.50	4	1				2105		152	152	0.00	2105			2105	0.072			16	47	0.026	12	18	
SA,RT	C,D	3.50	5	1	43			2105		31	116	0.79	2049			2049	0.072			16	47	0.026	12	18	
RT	D	3.50	5	1	40		N	1965		137	137	1.00	1894			1894	0.072	0.072		16	11	0.111	0	0	

NOTE : O - OPPOSING TRAFFIC N - NEAR SIDE LANE SG - STEADY GREEN FG - FLASHING GREEN PEDESTRIAN WALKING SPEED = 1.2m/s QUEUING LENGTH = AVERAGE QUEUE * 6m

OZZO TECHNOLOGY (HK) LIMITED

TRAFFIC SIGNAL CALCULATION

INITIALS

DATE

Proposed Minor Relaxation of Building Height Restriction for the Permitted Educational Institution (New Science Building) in "Government, Institution or Community" Zone at Lingnan University, No. 8 Castle Peak Road - Lingnan, Tuen Mun

PROJECT NO. 82904

Prepared By: LL

Jan-25

J1: Castle Peak Road - Lingnan / Castle Peak Road - Lam Tei

2024 PM

FILENAME :

Checked By: DP

Jan-25

2024 Observed PM Peak Hour Traffic Flows

Peak Road - Lam Tei_Castle Peak Road - Lingnan_S.xls

Reviewed By: OC

Jan-25

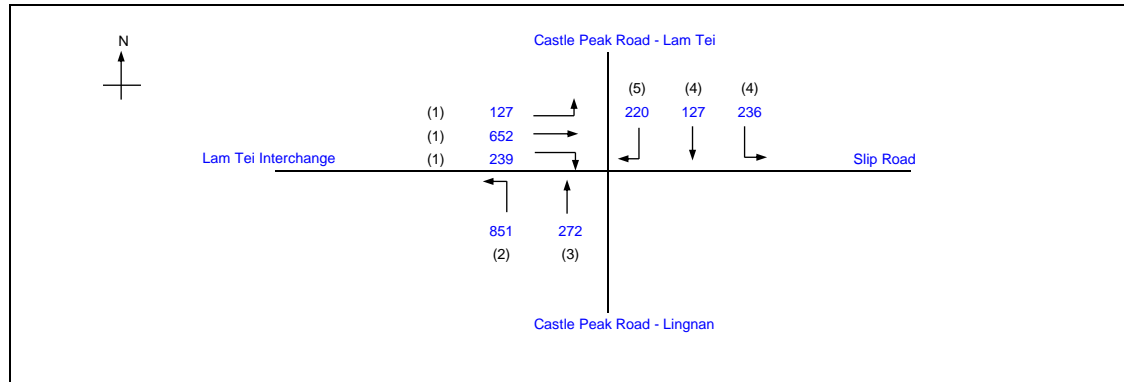

	Existing Cycle Time
No. of stages per cycle	N = 3
Cycle time	C = 110 sec
Sum(y)	Y = 0.292
Loss time	L = 16 sec
Total Flow	= 2724 pcu
Co = (1.5*L+5)/(1-Y)	= 41.0 sec
Cm = L/(1-Y)	= 22.6 sec
Yult	= 0.780
R.C.ult = (Yult-Y)/Y*100%	= 166.7 %
Cp = 0.9*L/(0.9-Y)	= 23.7 sec
Ymax = 1-L/C	= 0.855
R.C.(C) = (0.9*Ymax-Y)/Y*100%	= 163.0 %

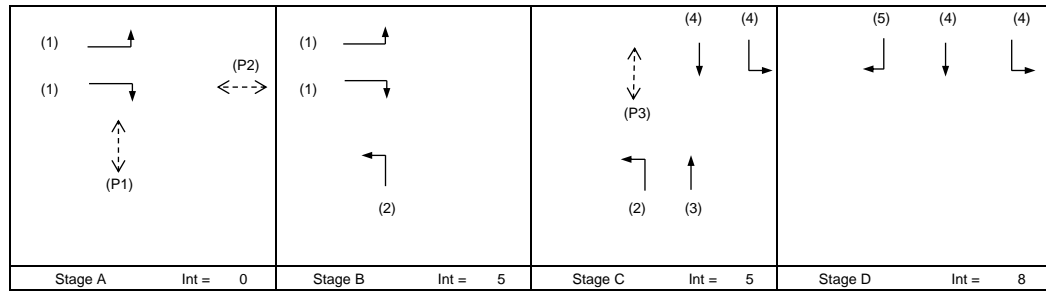

Pedestrian Phase	Stage	Length (m)	Green Time Required (s)			Green Time Provided (s)	
			SG	FG	Delay	SG	FG
P1	A	7	5	6	2	60	12
P2	A	7	5	6	14	26	16
P3	C	14	5	12	2	99	8

Move-ment	Stage	Lane Width m.	Phase	No. of lane	Radius m.	O	N	Straight-Ahead Sat. Flow	Movement			Total FFlow pcu/h	Proportion of Turning Vehicles	Sat. Flow pcu/h	Flare lane Length m.	Share Effect pcu/hr	Revised Sat. Flow pcu/h	y	Greater y	L sec	g (required) sec	g (input) sec	Degree of Saturation X	Queue Length (m / lane)	Average Delay (seconds)
									Left pcu/h	Straight pcu/h	Right pcu/h														
LT	A,B	3.40	1	1	15		N	1955	127		338	127	1.00	1777		1777	0.071		16	23	52	0.151	12	15	
LT,RT	A,B	3.30	1	1	34			2085	0		338	1997	1.00	1997		1997	0.169			54	52	0.358	30	18	
RT	A,B	3.30	1	1	31		N	1945			314	314	1.00	1855		1855	0.169	0.169		54	52	0.358	30	18	
RT	A,B	3.30	1	1	31		N	1945			239	239	1.00	1855		1855	0.129			41	52	0.273	0	0	
LT	B,C	3.30	2	2	14			4170	851			851	1.00	3766		3766	0.226			73	47	0.529	42	22	
SA	C	3.30	3	2				4170		272		272	0.00	4170		4170	0.065			21	47	0.153	12	18	
LT	C,D	3.30	4	1	100		N	1945	236			236	1.00	1916		1916	0.123	0.123		40	52	0.261	18	16	
SA	C,D	3.50	4	1				2105		121		121	0.00	2105		2105	0.057			18	40	0.023	12	22	
SA,RT	C,D	3.50	5	1	43			2105		6	111	117	0.95	2038		2038	0.057			18	40	0.023	12	22	
RT	D	3.50	5	1	40		N	1965			109	109	1.00	1894		1894	0.057			18	40	0.023	12	22	

NOTE : O - OPPOSING TRAFFIC

N - NEAR SIDE LANE

SG - STEADY GREEN

FG - FLASHING GREEN

PEDESTRIAN WALKING SPEED = 1.2m/s

QUEUING LENGTH = AVERAGE QUEUE * 6m

OZZO TECHNOLOGY (HK) LIMITED		TRAFFIC SIGNAL CALCULATION		INITIALS	DATE
Proposed Minor Relaxation of Building Height Restriction for the Permitted Educational Institution (New Science Building) in "Government, Institution or Community" Zone at Lingnan University, No. 8 Castle Peak Road - Lingnan, Tuen Mun		PROJECT NO.: 82904	PREPARED BY: LL	Jan/25	
J2: Lam Tei Interchange		2024 AM	FILENAME : J2_Lam Tei Interchange_R.xls	CHECKED BY: DP	Jan/25
2024 Observed AM Peak Hour Traffic Flows				REVIEWED BY: OC	Jan/25

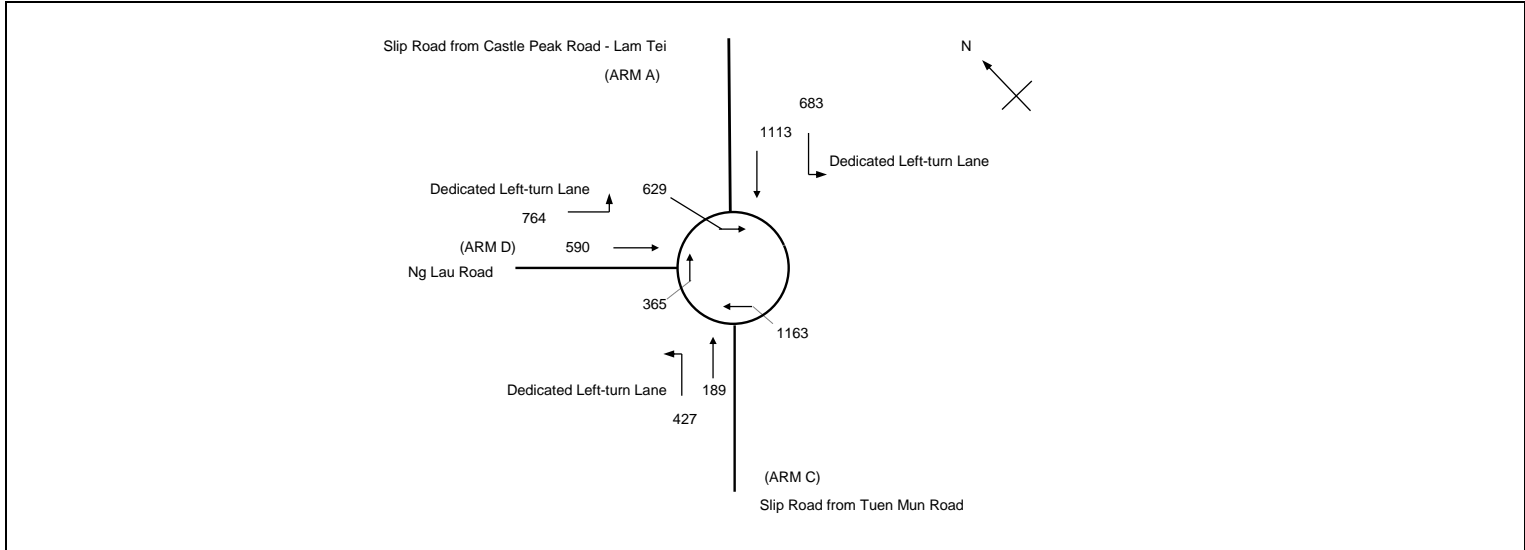

ARM	A	C	D		
INPUT PARAMETERS:					
V = Approach half width (m)	7.0	3.5	6.2		
E = Entry width (m)	7.2	3.7	7.2		
L = Effective length of flare (m)	4.0	18.0	9.1		
R = Entry radius (m)	33.0	77.2	67.5		
D = Inscribed circle diameter (m)	50.5	50.5	50.5		
A = Entry angle (degree)	19.0	20.0	15.0		
Q = Entry flow (pcu/h)	1113	189	590		
Qc = Circulating flow across entry (pcu/h)	629	1163	365		
OUTPUT PARAMETERS:					
S = Sharpness of flare = 1.6(E-V)/L	0.07	0.02	0.19		
K = 1-0.00347(A-30)-0.978(1/R-0.05)	1.06	1.07	1.09		
X2 = $V + ((E-V)/(1+2S))$	7.15	3.70	6.94		
M = $EXP((D-60)/10)$	0	0	0		
F = $303 * X2$	2166	1121	2102		
Td = $1+(0.5/(1+M))$	1.36	1.36	1.36		
Fc = $0.21 * Td(1+0.2 * X2)$	0.69	0.50	0.68		
Qe = $K(F-Fc * Qc)$	1829	581	2013	Total In Sum =	1326 PCU
DFC = Design flow/Capacity = Q/Qe	0.61	0.33	0.29	DFC of Critical Approach =	0.61

OZZO TECHNOLOGY (HK) LIMITED		TRAFFIC SIGNAL CALCULATION		INITIALS	DATE
Proposed Minor Relaxation of Building Height Restriction for the Permitted Educational Institution (New Science Building) in "Government, Institution or Community" Zone at Lingnan University, No. 8 Castle Peak Road - Lingnan, Tuen Mun		PROJECT NO.: 82904	PREPARED BY: LL	Jan/25	
J2: Lam Tei Interchange		2024 PM	FILENAME : J2_Lam Tei Interchange_R.xls	CHECKED BY: DP	Jan/25
2024 Observed PM Peak Hour Traffic Flows			REVIEWED BY: OC	Jan/25	

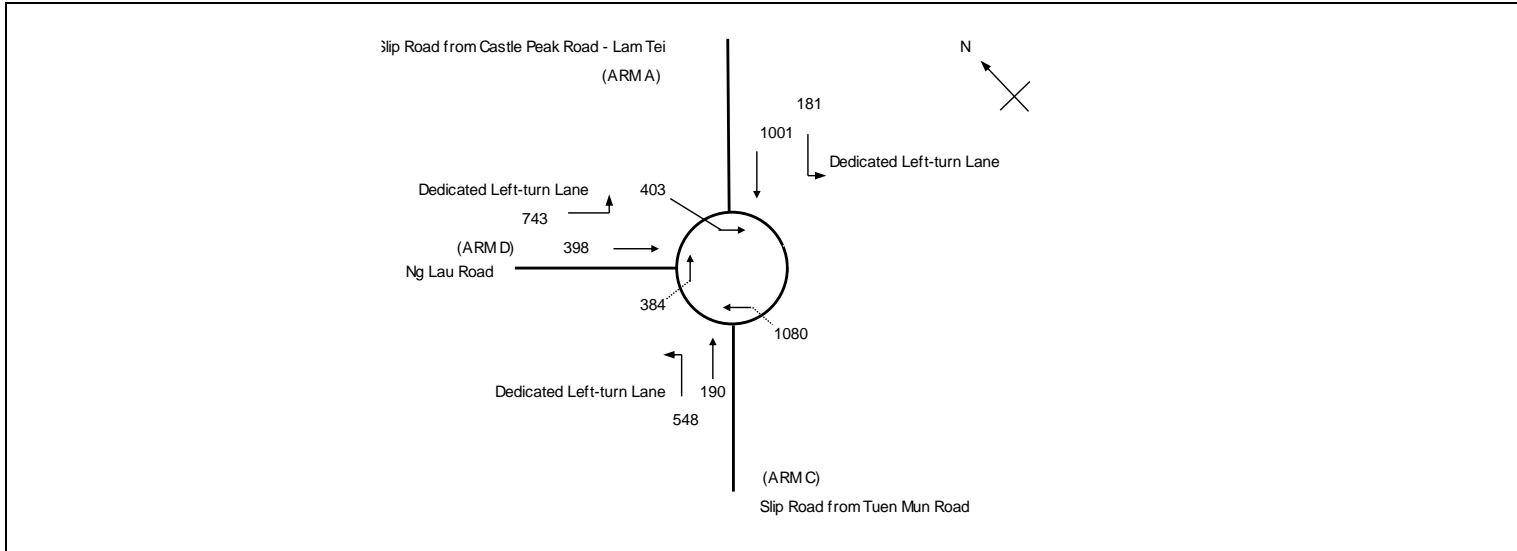

ARM	A	C	D		
INPUT PARAMETERS:					
V	= Approach half width (m)	7.0	3.5	6.2	
E	= Entry width (m)	7.2	3.7	7.2	
L	= Effective length of flare (m)	4.0	18.0	9.1	
R	= Entry radius (m)	33.0	77.2	67.5	
D	= Inscribed circle diameter (m)	50.5	50.5	50.5	
A	= Entry angle (degree)	19.0	20.0	15.0	
Q	= Entry flow (pcu/h)	1001	190	398	
Qc	= Circulating flow across entry (pcu/h)	403	1080	384	
OUTPUT PARAMETERS:					
S	= Sharpness of flare = 1.6(E-V)/L	0.07	0.02	0.19	
K	= 1-0.00347(A-30)-0.978(1/R-0.05)	1.06	1.07	1.09	
X2	= $V + ((E-V)/(1+2S))$	7.15	3.70	6.94	
M	= $EXP((D-60)/10)$	0	0	0	
F	= $303 \cdot X2$	2166	1121	2102	
Td	= $1+(0.5/(1+M))$	1.36	1.36	1.36	
Fc	= $0.21 \cdot Td(1+0.2 \cdot X2)$	0.69	0.50	0.68	
Qe	= $K(F-Fc \cdot Qc)$	1995	626	1999	
				Total In Sum =	1135 PCU
DFC	= Design flow/Capacity = Q/Qe	0.50	0.30	0.20	DFC of Critical Approach = 0.50

OZZO TECHNOLOGY (HK) LIMITED	PRIORITY JUNCTION CALCULATION	INITIALS	DATE
-------------------------------------	--------------------------------------	----------	------

Proposed Minor Relaxation of Building Height Restriction for the Permitted Educational Institution (New Science Building) in "Government, Institution or Community" Zone at Lingnan University, No. 8 Castle Peak Road - Lingnan, Tuen Mun	PROJECT NO.: 82904	PREPARED BY: LL	Jan-25
--	--------------------	-----------------	--------

J3 : Tuen Kwai Road / Northern Access of Lingnan University	2024 AM	CHECKED BY: DP	Jan-25
2024 Observed Weekday AM Peak Hour Traffic Flows	FILENAME : 3_Tuen Kwai Road_Northern Access of Lingnan University_P.xls	REVIEWED BY: OC	Jan-25

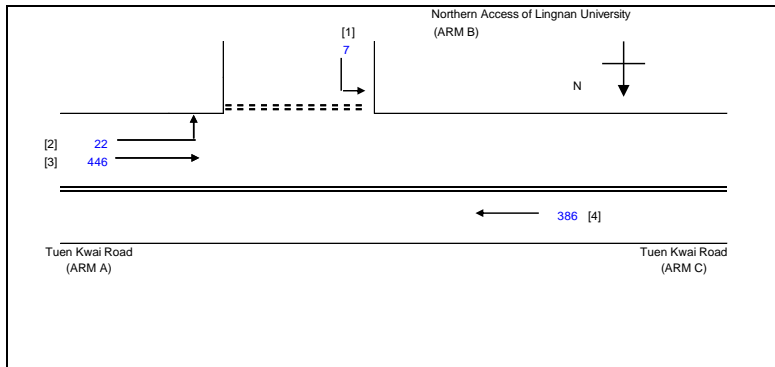

NOTES : (GEOMETRIC INPUT DATA)

- W = MAJOR ROAD WIDTH
- W cr = CENTRAL RESERVE WIDTH
- W b-a = LANE WIDTH AVAILABLE TO VEHICLE WAITING IN STREAM b-a
- W b-c = LANE WIDTH AVAILABLE TO VEHICLE WAITING IN STREAM b-c
- W c-b = LANE WIDTH AVAILABLE TO VEHICLE WAITING IN STREAM c-b
- Vi b-a = VISIBILITY TO THE LEFT FOR VEHICLES WAITING IN STREAM b-a
- Vr b-a = VISIBILITY TO THE RIGHT FOR VEHICLES WAITING IN STREAM b-a
- Vr b-c = VISIBILITY TO THE RIGHT FOR VEHICLES WAITING IN STREAM b-c
- Vr c-b = VISIBILITY TO THE RIGHT FOR VEHICLES WAITING IN STREAM c-b
- D = STREAM-SPECIFIC B-A
- E = STREAM-SPECIFIC B-C
- F = STREAM-SPECIFIC C-B
- Y = (1-0.0345W)

GEOMETRIC DETAILS:	GEOMETRIC FACTORS :	THE CAPACITY OF MOVEMENT :	COMPARISON OF DESIGN FLOW TO CAPACITY:
MAJOR ROAD (ARM A) W = 10.05 (metres) W cr = 2.5 (metres) q a-b = 22 (pcu/hr) q a-c = 446 (pcu/hr)	D = 0.60872348 E = 1.312020493 F = 0.8390018 Y = 0.6534475	Q b-a = 302 Q b-c = 836 Q c-b = 532 Q b-c (O) = 836 TOTAL FLOW = 475 (PCU/HR)	DFC b-a = 0.0000 DFC b-c = 0.0084 DFC c-b = 0.0000
MAJOR ROAD (ARM C) W c-b = 2.82 (metres) Vr c-b = 20 (metres) q c-a = 386 (pcu/hr) q c-b = (pcu/hr)			
MINOR ROAD (ARM B) W b-a = (metres) W b-c = 7.42 (metres) Vi b-a = 78 (metres) Vr b-a = 85 (metres) Vr b-c = 85 (metres) q b-a = (pcu/hr) q b-c = 7 (pcu/hr)			
CRITICAL DFC			= 0.01

OZZO TECHNOLOGY (HK) LIMITED	PRIORITY JUNCTION CALCULATION	INITIALS	DATE
-------------------------------------	--------------------------------------	----------	------

Proposed Minor Relaxation of Building Height Restriction for the Permitted Educational Institution (New Science Building) in "Government, Institution or Community" Zone at Lingnan University, No. 8 Castle Peak Road - Lingnan, Tuen Mun	PROJECT NO.: 82904	PREPARED BY: LL	Jan-25
--	--------------------	-----------------	--------

J3 : Tuen Kwai Road / Northern Access of Lingnan University	2024 PM	FILENAME : 3_Tuen Kwai Road_Northern Access of Lingnan University_P.xls	CHECKED BY: DP	Jan-25
2024 Observed Weekday PM Peak Hour Traffic Flows			REVIEWED BY: OC	Jan-25

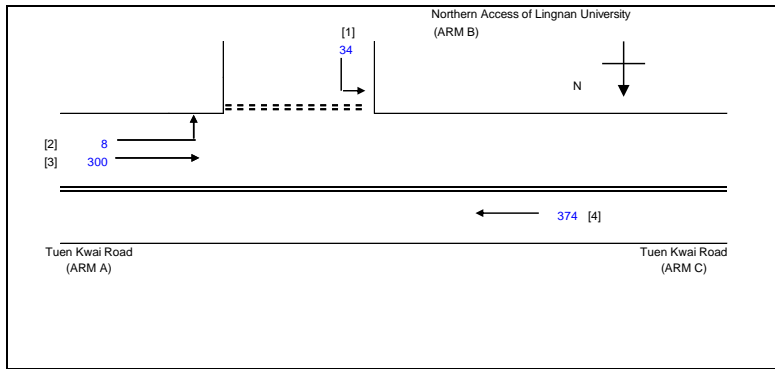

NOTES : (GEOMETRIC INPUT DATA)

- W = MAJOR ROAD WIDTH
- W cr = CENTRAL RESERVE WIDTH
- W b-a = LANE WIDTH AVAILABLE TO VEHICLE WAITING IN STREAM b-a
- W b-c = LANE WIDTH AVAILABLE TO VEHICLE WAITING IN STREAM b-c
- W c-b = LANE WIDTH AVAILABLE TO VEHICLE WAITING IN STREAM c-b
- Vi b-a = VISIBILITY TO THE LEFT FOR VEHICLES WAITING IN STREAM b-a
- Vr b-a = VISIBILITY TO THE RIGHT FOR VEHICLES WAITING IN STREAM b-a
- Vr b-c = VISIBILITY TO THE RIGHT FOR VEHICLES WAITING IN STREAM b-c
- Vr c-b = VISIBILITY TO THE RIGHT FOR VEHICLES WAITING IN STREAM c-b
- D = STREAM-SPECIFIC B-A
- E = STREAM-SPECIFIC B-C
- F = STREAM-SPECIFIC C-B
- Y = (1-0.0345W)

GEOMETRIC DETAILS:	GEOMETRIC FACTORS :	THE CAPACITY OF MOVEMENT :	COMPARISON OF DESIGN FLOW TO CAPACITY:
MAJOR ROAD (ARM A) W = 10.05 (metres) W cr = 2.5 (metres) q a-b = 8 (pcu/hr) q a-c = 300 (pcu/hr)	D = 0.60872348 E = 1.312020493 F = 0.8390018 Y = 0.6534475	Q b-a = 325 Q b-c = 883 Q c-b = 564 Q b-c (O) = 883 TOTAL FLOW = 342 (PCU/HR)	DFC b-a = 0.0000 DFC b-c = 0.0385 DFC c-b = 0.0000
MAJOR ROAD (ARM C) W c-b = 2.82 (metres) Vr c-b = 20 (metres) q c-a = 374 (pcu/hr) q c-b = (pcu/hr)			
MINOR ROAD (ARM B) W b-a = (metres) W b-c = 7.42 (metres) Vi b-a = 78 (metres) Vr b-a = 85 (metres) Vr b-c = 85 (metres) q b-a = (pcu/hr) q b-c = 34 (pcu/hr)			
CRITICAL DFC			= 0.04

OZZO TECHNOLOGY (HK) LIMITED

TRAFFIC SIGNAL CALCULATION

INITIALS DATE

Proposed Minor Relaxation of Building Height Restriction for the Permitted Educational Institution (New Science Building) in "Government, Institution or Community" Zone at Lingnan University, No. 8 Castle Peak Road - Lingnan, Tuen Mun

PROJECT NO. 82904

Prepared By: LL

Jan-25

J4: Castle Peak Road - Lingnan / Tuen Fu Road / Tuen Kwai Road

2024 AM

FILENAME :

Checked By: DP

Jan-25

2024 Observed AM Peak Hour Traffic Flows

J4_Castle Peak Road - Lingnan_Tuen Fu Road_Tuen Kwai

Reviewed By: OC

Jan-25

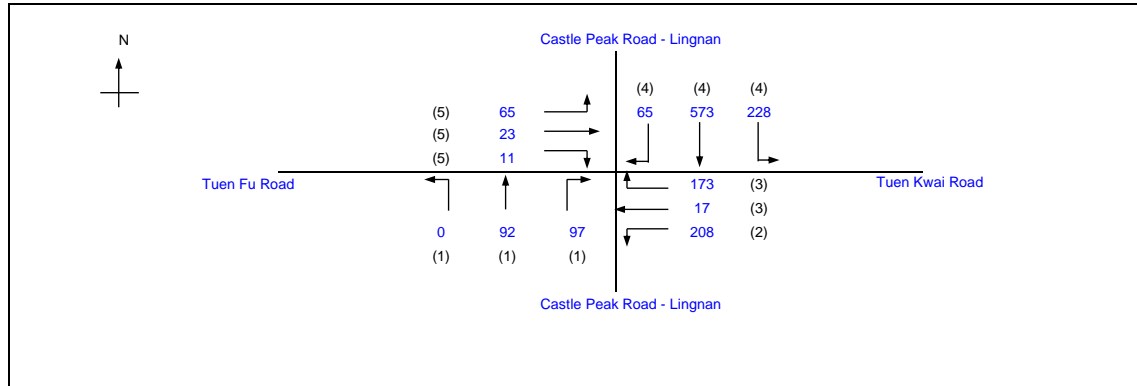

		Existing Cycle Time	
No. of stages per cycle	N =	4	
Cycle time	C =	120 sec	
Sum(y)	Y =	0.354	
Loss time	L =	20 sec	
Total Flow	=	1552 pcu	
Co = (1.5*L+5)/(1-Y)	=	54.2 sec	
Cm = L/(1-Y)	=	31.0 sec	
Yult	=	0.750	
R.C.ult = (Yult-Y)/Y*100%	=	111.7 %	
Cp = 0.9*L/(0.9-Y)	=	33.0 sec	
Ymax = 1-L/C	=	0.833	
R.C.(C) = (0.9*Ymax-Y)/Y*100%	=	111.7 %	

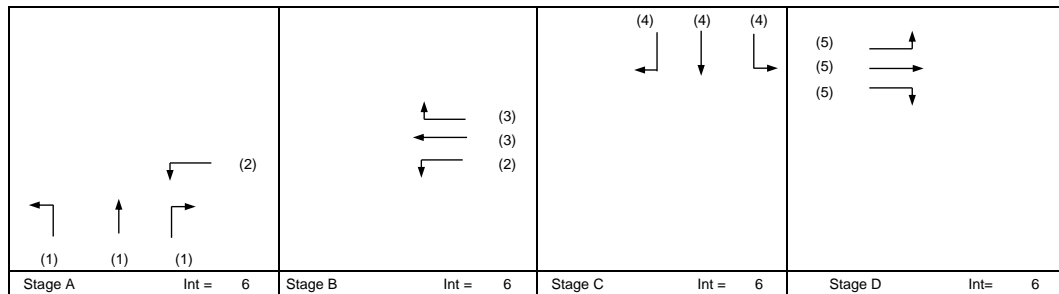

Pedestrian Phase	Stage	Length (m)	Green Time Required (s)			Green Time Provided (s)	
			SG	FG	Delay	SG	FG

Movement	Stage	Lane Width (m)	Phase	No. of lane	Radius (m)	O	N	Straight-Ahead Sat. Flow	Movement			Total FLOW pcu/h	Proportion of Turning Vehicles	Sat. Flow pcu/h	Flare lane Length (m)	Share Effect pcu/hr	Revised Sat. Flow pcu/h	y	Greater y	L (sec)	g (required) (sec)	g (input) (sec)	Degree of Saturation X	Queue Length (m / lane)	Average Delay (seconds)
									Left pcu/h	Straight pcu/h	Right pcu/h														
LT,SA	A	3.58	1	1	9			2113	0	46		46	0.00	2113			2113	0.022		20	6	19	0.023	6	40
SA	A	3.53	1	1				2108		46		46	0.00	2108			2108	0.022			6	19	0.023	0	0
RT	A	3.69	1	1	18			2124			97	97	1.00	1961			1961	0.049	0.049		14	19	0.052	12	43
LT	A,B	3.25	2	1	25			2080	208			208	1.00	1962			1962	0.106			30	60	0.035	18	16
SA, RT	B	3.50	3	1	12			2105		17	173	190	0.91	1890			1890	0.101	0.101		28	36	0.056	24	31
LT,SA	C	3.70	4	1	11			2125	65	250		315	0.21	2067			2067	0.153			43	31	0.098	42	39
SA	C	3.59	4	1				2114		323		323	0.00	2114			2114	0.153	0.153		43	31	0.098	0	0
RT	C	3.59	4	1	17			2114			228	228	1.00	1943			1943	0.117			33	31	0.076	30	36
LT,SA,RT	D	3.46	5	1	12			2101	65	23	11	99	0.77	1917			1917	0.052	0.052		15	14	0.074	12	50

NOTE : O - OPPOSING TRAFFIC

N - NEAR SIDE LANE

SG - STEADY GREEN

FG - FLASHING GREEN

PEDESTRIAN WALKING SPEED = 1.2m/s

QUEUING LENGTH = AVERAGE QUEUE * 6m

OZZO TECHNOLOGY (HK) LIMITED

TRAFFIC SIGNAL CALCULATION

INITIALS DATE

Proposed Minor Relaxation of Building Height Restriction for the Permitted Educational Institution (New Science Building) in "Government, Institution or Community" Zone at Lingnan University, No. 8 Castle Peak Road - Lingnan, Tuen Mun

PROJECT NO. 82904

Prepared By: LL

Jan-25

J4: Castle Peak Road - Lingnan / Tuen Fu Road / Tuen Kwai Road

2024 PM

FILENAME :

Checked By: DP

Jan-25

2024 Observed PM Peak Hour Traffic Flows

J4_Castle Peak Road - Lingnan_Tuen Fu Road_Tuen Kwai

Reviewed By: SC

Jan-25

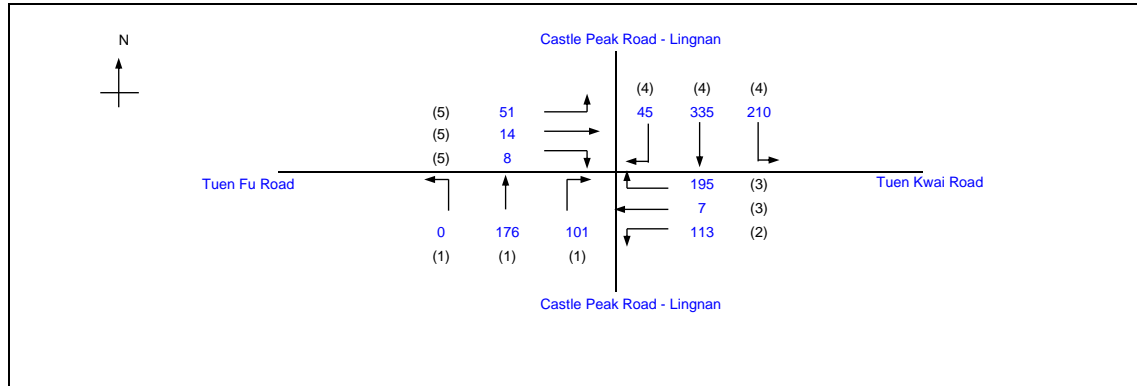

		Existing Cycle Time	
No. of stages per cycle	N =	4	
Cycle time	C =	110 sec	
Sum(y)	Y =	0.305	
Loss time	L =	20 sec	
Total Flow	=	1255 pcu	
Co	= (1.5*L+5)/(1-Y)	=	50.4 sec
Cm	= L/(1-Y)	=	28.8 sec
Yult	=	0.750	
R.C.ult	= (Yult-Y)/Y*100%	=	145.6 %
Cp	= 0.9*L/(0.9-Y)	=	30.3 sec
Ymax	= 1-L/C	=	0.818
R.C.(C)	= (0.9*Ymax-Y)/Y*100%	=	141.1 %

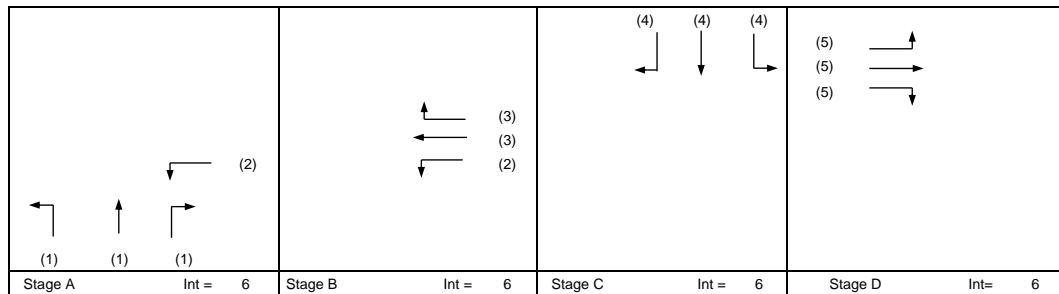

Pedestrian Phase	Stage	Length (m)	Green Time Required (s)			Green Time Provided (s)	
			SG	FG	Delay	SG	FG

Movement	Stage	Lane Width m.	Phase	No. of lane	Radius m.	O	N	Straight-Ahead Sat. Flow	Movement			Total FLOW pcu/h	Proportion of Turning Vehicles	Sat. Flow pcu/h	Flare lane Length m.	Share Effect pcu/hr	Revised Sat. Flow pcu/h	y	Greater y	L sec	g (required) sec	g (input) sec	Degree of Saturation X	Queue Length (m / lane)	Average Delay (seconds)
									Left pcu/h	Straight pcu/h	Right pcu/h														
LT,SA	A	3.58	1	1	9			2113	0	88		88	0.00	2113			2113	0.042		20	12	24	0.035	12	32
SA	A	3.53	1	1				2108		88		88	0.00	2108			2108	0.042			12	24	0.035	0	0
RT	A	3.69	1	1	18			2124			101	101	1.00	1961			1961	0.052	0.052		15	24	0.043	12	33
LT	A,B	3.25	2	1	25			2080	113			113	1.00	1962			1962	0.058			17	50	0.023	6	16
SA, RT	B	3.50	3	1	12			2105		7	195	202	0.97	1878			1878	0.108	0.108		32	21	0.102	24	42
LT,SA	C	3.70	4	1	11			2125	45	142		187	0.24	2058			2058	0.091			27	31	0.059	24	29
SA	C	3.59	4	1				2114		193		193	0.00	2114			2114	0.091			27	31	0.059	0	0
RT	C	3.59	4	1	17			2114			210	210	1.00	1943			1943	0.108	0.108		32	31	0.070	24	30
LT,SA,RT	D	3.46	5	1	12			2101	51	14	8	73	0.81	1908			1908	0.038	0.038		11	14	0.055	6	42

NOTE : O - OPPOSING TRAFFIC

N - NEAR SIDE LANE

SG - STEADY GREEN

FG - FLASHING GREEN

PEDESTRIAN WALKING SPEED = 1.2m/s

QUEUING LENGTH = AVERAGE QUEUE * 6m

OZZO TECHNOLOGY (HK) LIMITED		PRIORITY JUNCTION CALCULATION		INITIALS	DATE
Proposed Minor Relaxation of Building Height Restriction for the Permitted Educational Institution (New Science Building) in "Government, Institution or Community" Zone at Lingnan University, No. 8 Castle Peak Road - Lingnan, Tuen Mun		PROJECT NO.:	82904	PREPARED BY:	LL Jan-25
J5 : Castle Peak Road - Lingnan / Fu Tei Road	2024 AM	FILENAME :		CHECKED BY:	DP Jan-25
2024 Observed Weekday AM Peak Hour Traffic Flows		J5_Castle Peak Road - Lingnan_Fu Tei Road_P.xls		REVIEWED BY:	OC Jan-25

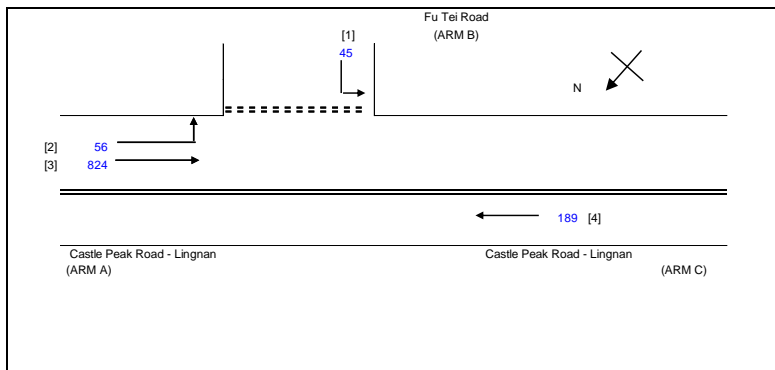

NOTES : (GEOMETRIC INPUT DATA)

W = MAJOR ROAD WIDTH
W cr = CENTRAL RESERVE WIDTH
W b-a = LANE WIDTH AVAILABLE TO VEHICLE WAITING IN STREAM b-a
W b-c = LANE WIDTH AVAILABLE TO VEHICLE WAITING IN STREAM b-c
W c-b = LANE WIDTH AVAILABLE TO VEHICLE WAITING IN STREAM c-b
Vl b-a = VISIBILITY TO THE LEFT FOR VEHICLES WAITING IN STREAM b-a
Vr b-a = VISIBILITY TO THE RIGHT FOR VEHICLES WAITING IN STREAM b-a
Vr b-c = VISIBILITY TO THE RIGHT FOR VEHICLES WAITING IN STREAM b-c
Vr c-b = VISIBILITY TO THE RIGHT FOR VEHICLES WAITING IN STREAM c-b
D = STREAM-SPECIFIC B-A
E = STREAM-SPECIFIC B-C
F = STREAM-SPECIFIC C-B
Y = (1-0.0345W)

GEOMETRIC DETAILS:

MAJOR ROAD (ARM A)
W = 15.94 (metres)
W cr = 2.2 (metres)
q a-b = 56 (pcu/hr)
q a-c = 824 (pcu/hr)

MAJOR ROAD (ARM C)
W c-b = 7.45 (metres)
Vr c-b = 30 (metres)
q c-a = 189 (pcu/hr)
q c-b = (pcu/hr)

MINOR ROAD (ARM B)
W b-a = 4.78 (metres)
W b-c = (metres)
Vl b-a = 88 (metres)
Vr b-a = 78 (metres)
Vr b-c = 78 (metres)
q b-a = (pcu/hr)
q b-c = 45 (pcu/hr)

GEOMETRIC FACTORS :

D = 1.024809022
E = 0.63206918
F = 1.2472668
Y = 0.4502425

THE CAPACITY OF MOVEMENT :

Q b-a = 512
Q b-c = 383
Q c-b = 749
TOTAL FLOW = 925 (PCU/HR)

COMPARISON OF DESIGN FLOW TO CAPACITY:

DFC b-a = 0.0000
DFC b-c = 0.1175
DFC c-b = 0.0000

CRITICAL DFC = 0.12

OZZO TECHNOLOGY (HK) LIMITED		PRIORITY JUNCTION CALCULATION		INITIALS	DATE
Proposed Minor Relaxation of Building Height Restriction for the Permitted Educational Institution (New Science Building) in "Government, Institution or Community" Zone at Lingnan University, No. 8 Castle Peak Road - Lingnan, Tuen Mun			PROJECT NO.:	82904	PREPARED BY: LL Jan-25
J5 : Castle Peak Road - Lingnan / Fu Tei Road		2024 PM	FILENAME :	CHECKED BY: DP Jan-25	
2024 Observed Weekday PM Peak Hour Traffic Flows			J5_Castle Peak Road - Lingnan_Fu Tei Road_P.xls	REVIEWED BY: OC Jan-25	

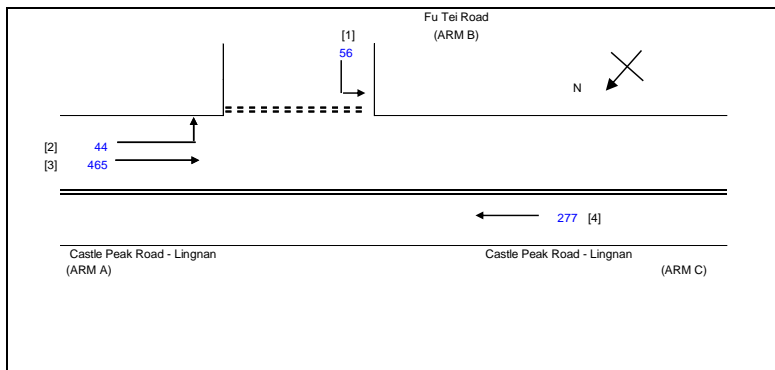

- NOTES : (GEOMETRIC INPUT DATA)
- W = MAJOR ROAD WIDTH
 - W cr = CENTRAL RESERVE WIDTH
 - W b-a = LANE WIDTH AVAILABLE TO VEHICLE WAITING IN STREAM b-a
 - W b-c = LANE WIDTH AVAILABLE TO VEHICLE WAITING IN STREAM b-c
 - W c-b = LANE WIDTH AVAILABLE TO VEHICLE WAITING IN STREAM c-b
 - VI b-a = VISIBILITY TO THE LEFT FOR VEHICLES WAITING IN STREAM b-a
 - Vr b-a = VISIBILITY TO THE RIGHT FOR VEHICLES WAITING IN STREAM b-a
 - Vr b-c = VISIBILITY TO THE RIGHT FOR VEHICLES WAITING IN STREAM b-c
 - Vr c-b = VISIBILITY TO THE RIGHT FOR VEHICLES WAITING IN STREAM c-b
 - D = STREAM-SPECIFIC B-A
 - E = STREAM-SPECIFIC B-C
 - F = STREAM-SPECIFIC C-B
 - Y = (1-0.0345W)

GEOMETRIC DETAILS:

MAJOR ROAD (ARM A)

W = 15.94 (metres)

W cr = 2.2 (metres)

q a-b = 44 (pcu/hr)

q a-c = 465 (pcu/hr)

MAJOR ROAD (ARM C)

W c-b = 7.45 (metres)

Vr c-b = 30 (metres)

q c-a = 277 (pcu/hr)

q c-b = (pcu/hr)

MINOR ROAD (ARM B)

W b-a = 4.78 (metres)

W b-c = (metres)

VI b-a = 88 (metres)

Vr b-a = 78 (metres)

Vr b-c = 78 (metres)

q b-a = (pcu/hr)

q b-c = 56 (pcu/hr)

GEOMETRIC FACTORS :

D = 1.024809022

E = 0.63206918

F = 1.2472668

Y = 0.4502425

THE CAPACITY OF MOVEMENT :

Q b-a = 564

Q b-c = 421

Q c-b = 825

Q b-c (O) = 421

TOTAL FLOW = 565 (PCU/HR)

COMPARISON OF DESIGN FLOW TO CAPACITY:

DFC b-a = 0.0000

DFC b-c = 0.1330

DFC c-b = 0.0000

CRITICAL DFC = 0.13

OZZO TECHNOLOGY (HK) LIMITED

PRIORITY JUNCTION CALCULATION

INITIALS

DATE

Proposed Minor Relaxation of Building Height Restriction for the Permitted Educational Institution (New Science Building) in "Government, Institution or Community" Zone at Lingnan University, No. 8 Castle Peak Road - Lingnan, Tuen Mun

PROJECT NO.: 82904

PREPARED BY: LL

Jan-25

J6: Fu Tei Road / Southern Access of Lingnan University

2024 AM

FILENAME :

CHECKED BY: DP

Jan-25

2024 Observed Weekday AM Peak Hour Traffic Flows

Ju Tei Road_Southern Access of Lingnan University_P.xls

REVIEWED BY: OC

Jan-25

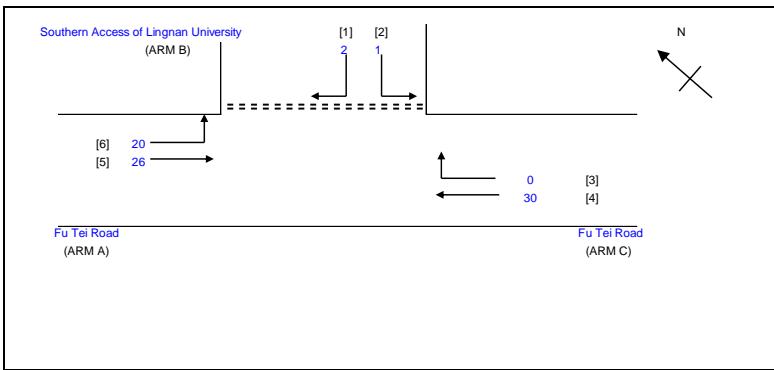

NOTES : (GEOMETRIC INPUT DATA)

- W = MAJOR ROAD WIDTH
- W cr = CENTRAL RESERVE WIDTH
- W b-a = LANE WIDTH AVAILABLE TO VEHICLE WAITING IN STREAM b-a
- W b-c = LANE WIDTH AVAILABLE TO VEHICLE WAITING IN STREAM b-c
- W c-b = LANE WIDTH AVAILABLE TO VEHICLE WAITING IN STREAM c-b
- Vi b-a = VISIBILITY TO THE LEFT FOR VEHICLES WAITING IN STREAM b-a
- Vr b-a = VISIBILITY TO THE RIGHT FOR VEHICLES WAITING IN STREAM b-a
- Vr b-c = VISIBILITY TO THE RIGHT FOR VEHICLES WAITING IN STREAM b-c
- Vr c-b = VISIBILITY TO THE RIGHT FOR VEHICLES WAITING IN STREAM c-b
- D = STREAM-SPECIFIC B-A
- E = STREAM-SPECIFIC B-C
- F = STREAM-SPECIFIC C-B
- Y = (1-0.0345W)

GEOMETRIC DETAILS:

GEOMETRIC FACTORS :

THE CAPACITY OF MOVEMENT :

COMPARISON OF DESIGN FLOW TO CAPACITY:

MAJOR ROAD (ARM A)
 W = 7.61 (metres)
 W cr = 0 (metres)
 q a-b = 20 (pcu/hr)
 q a-c = 26 (pcu/hr)

D = 0.895777361
 E = 0.94992297
 F = 0.9319579
 Y = 0.737455

Q b-a = 549
 Q b-c = 699
 Q c-b = 683
 Q b-ac = 549

DFC b-a = 0.0036
 DFC b-c = 0.0014
 DFC c-b = 0.0000
 DFC b-c (share lane) = 0.0055

MAJOR ROAD (ARM C)
 W c-b = 3.8 (metres)
 Vr c-b = 30 (metres)
 q c-a = 30 (pcu/hr)
 q c-b = 0 (pcu/hr)

F for (Qb-ac) = 0

TOTAL FLOW = 79 (PCU/HR)

CRITICAL DFC = 0.01

MINOR ROAD (ARM B)
 W b-a = 3.3 (metres)
 W b-c = 3.3 (metres)
 Vi b-a = 55 (metres)
 Vr b-a = 100 (metres)
 Vr b-c = 100 (metres)
 q b-a = 2 (pcu/hr)
 q b-c = 1 (pcu/hr)

OZZO TECHNOLOGY (HK) LIMITED

PRIORITY JUNCTION CALCULATION

INITIALS

DATE

Proposed Minor Relaxation of Building Height Restriction for the Permitted Educational Institution (New Science Building) in "Government, Institution or Community" Zone at Lingnan University, No. 8 Castle Peak Road - Lingnan, Tuen Mun

PROJECT NO.: 82904

PREPARED BY: LL

Jan-25

J6: Fu Tei Road / Southern Access of Lingnan University

2024 PM

FILENAME :

CHECKED BY: DP

Jan-25

2024 Observed Weekday PM Peak Hour Traffic Flows

Ju Tei Road_Southern Access of Lingnan University_P.xls

REVIEWED BY: OC

Jan-25

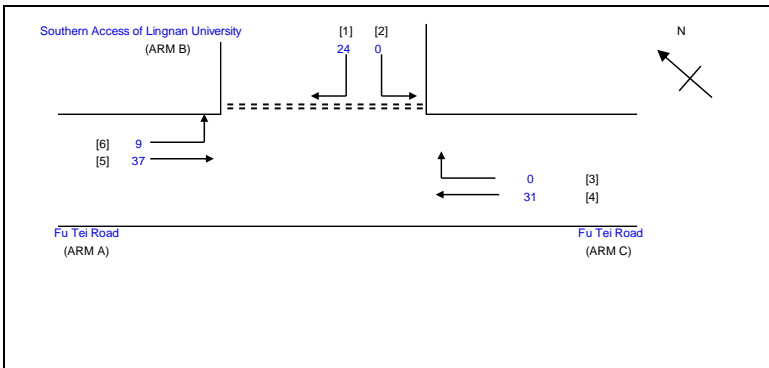

NOTES : (GEOMETRIC INPUT DATA)

- W = MAJOR ROAD WIDTH
- W cr = CENTRAL RESERVE WIDTH
- W b-a = LANE WIDTH AVAILABLE TO VEHICLE WAITING IN STREAM b-a
- W b-c = LANE WIDTH AVAILABLE TO VEHICLE WAITING IN STREAM b-c
- W c-b = LANE WIDTH AVAILABLE TO VEHICLE WAITING IN STREAM c-b
- VI b-a = VISIBILITY TO THE LEFT FOR VEHICLES WAITING IN STREAM b-a
- Vr b-a = VISIBILITY TO THE RIGHT FOR VEHICLES WAITING IN STREAM b-a
- Vr b-c = VISIBILITY TO THE RIGHT FOR VEHICLES WAITING IN STREAM b-c
- Vr c-b = VISIBILITY TO THE RIGHT FOR VEHICLES WAITING IN STREAM c-b
- D = STREAM-SPECIFIC B-A
- E = STREAM-SPECIFIC B-C
- F = STREAM-SPECIFIC C-B
- Y = (1-0.0345W)

GEOMETRIC DETAILS:

MAJOR ROAD (ARM A)
 W = 7.61 (metres)
 W cr = 0 (metres)
 q a-b = 9 (pcu/hr)
 q a-c = 37 (pcu/hr)

GEOMETRIC FACTORS :

D = 0.895777361
 E = 0.94992297
 F = 0.9319579
 Y = 0.737455

THE CAPACITY OF MOVEMENT :

Q b-a = 547
 Q b-c = 697
 Q c-b = 683
 Q b-ac = 547

COMPARISON OF DESIGN FLOW TO CAPACITY:

DFC b-a = 0.0439
 DFC b-c = 0.0000
 DFC c-b = 0.0000
 DFC b-c (share lane) = 0.0439

MAJOR ROAD (ARM C)
 W c-b = 3.8 (metres)
 Vr c-b = 30 (metres)
 q c-a = 31 (pcu/hr)
 q c-b = 0 (pcu/hr)

F for (Qb-ac) = 0

TOTAL FLOW = 101 (PCU/HR)

CRITICAL DFC = 0.04

MINOR ROAD (ARM B)
 W b-a = 3.3 (metres)
 W b-c = 3.3 (metres)
 VI b-a = 55 (metres)
 Vr b-a = 100 (metres)
 Vr b-c = 100 (metres)
 q b-a = 24 (pcu/hr)
 q b-c = 0 (pcu/hr)

Annex D

2031 Junction Calculation Sheets

Proposed Minor Relaxation of Building Height Restriction for the Permitted Educational Institution (New Science Building) in "Government, Institution or Community" Zone at Lingnan University, No. 8 Castle Peak Road - Lingnan, Tuen Mun

PROJECT NO. 82904

Prepared By: LL

Jan-25

J1: Castle Peak Road - Lingnan / Castle Peak Road - Lam Tei

2031 Ref_AM

FILENAME :

Checked By: DP

Jan-25

2031 Reference Weekday AM Peak Hour Traffic Flows

Peak Road - Lam Tei_Castle Peak Road - Lingnan_S.xls

Reviewed By: OC

Jan-25

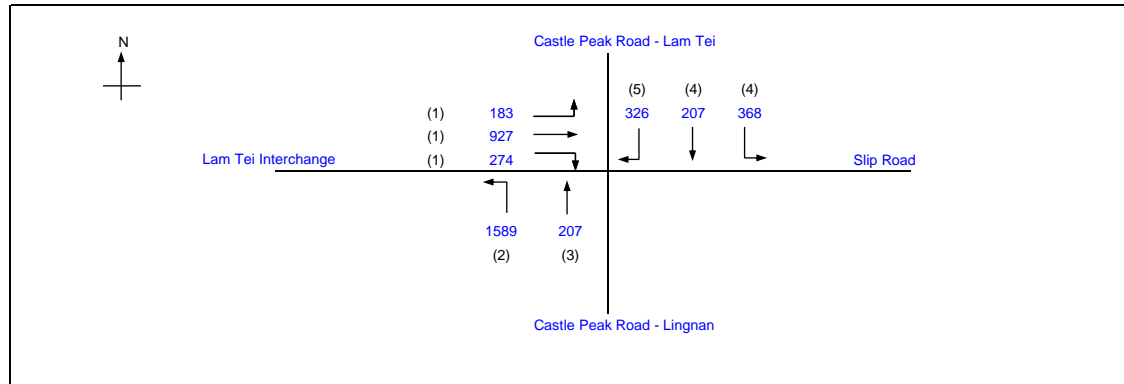

		Existing Cycle Time
No. of stages per cycle	N =	3
Cycle time	C =	110 sec
Sum(y)	Y =	0.510
Loss time	L =	16 sec
Total Flow	=	3430 pcu
Co	= $(1.5 \cdot L + 5) / (1 - Y)$	= 59.2 sec
Cm	= $L / (1 - Y)$	= 32.7 sec
Yult	=	0.780
R.C.ult	= $(Yult - Y) / Y \cdot 100\%$	= 52.8 %
Cp	= $0.9 \cdot L / (0.9 - Y)$	= 37.0 sec
Ymax	= $1 - L/C$	= 0.855
R.C.(C)	= $(0.9 \cdot Ymax - Y) / Y \cdot 100\%$	= 50.7 %

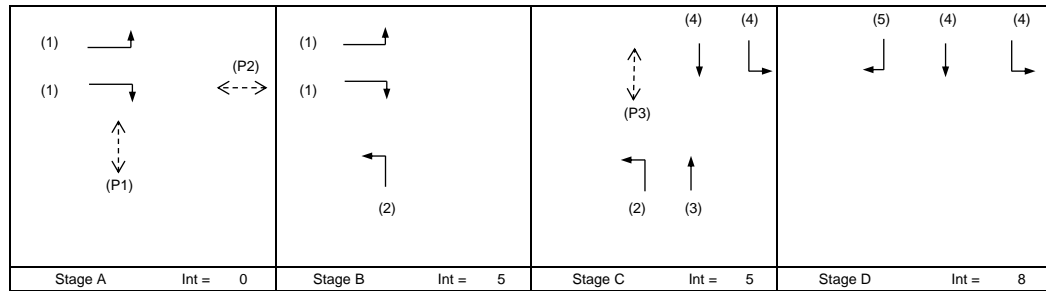

Pedestrian Phase	Stage	Length (m)	Green Time Required (s)			Green Time Provided (s)	
			SG	FG	Delay	SG	FG
P1	A	7	5	6	2	60	12
P2	A	7	5	6	14	26	16
P3	C	14	5	12	2	99	8

Move-ment	Stage	Lane Width m.	Phase	No. of lane	Radius m.	O	N	Straight-Ahead Sat. Flow	Movement			Total FFlow pcu/h	Proportion of Turning Vehicles	Sat. Flow pcu/h	Flare lane Length m.	Share Effect pcu/hr	Revised Sat. Flow pcu/h	y	Greater y	L sec	g (required) sec	g (input) sec	Degree of Saturation X	Queue Length (m / lane)	Average Delay (seconds)
									Left pcu/h	Straight pcu/h	Right pcu/h														
LT	A,B	3.40	1	1	15		N	1955	144			144	1.00	1777		1777	0.081		16	15	15	0.597	18	50	
LT,RT	A,B	3.30	1	1	34			2085	39		124	162	1.00	1997		1997	0.081			15	15	0.597	24	49	
RT	A,B	3.30	1	1	31		N	1945			151	151	1.00	1855		1855	0.081			15	15	0.597	24	50	
RT	A,B	3.30	1	1	31		N	1945			274	274	1.00	1855		1855	0.148			27	27	0.597	0	0	
LT	B,C	3.30	2	2	14			4170	1589			1589	1.00	3766		3766	0.422	0.422		78	78	0.597	42	8	
SA	C	3.30	3	2				4170		207	207	0.00	4170		4170	0.050				9	9	0.597	15	51	
LT	C,D	3.30	4	1	100		N	1945	368			368	1.00	1916		1916	0.192			35	35	0.597	42	32	
SA	C,D	3.50	4	1				2105		186	186	0.00	2105		2105	0.088				16	16	0.087	24	47	
SA,RT	C,D	3.50	5	1	43			2105		21	159	180	0.88	2042		2042	0.088			16	16	0.087	24	47	
RT	D	3.50	5	1	40		N	1965			167	167	1.00	1894		1894	0.088	0.088		16	16	0.087	24	48	

NOTE : O - OPPOSING TRAFFIC

N - NEAR SIDE LANE

SG - STEADY GREEN

FG - FLASHING GREEN

PEDESTRIAN WALKING SPEED = 1.2m/s

QUEUING LENGTH = AVERAGE QUEUE * 6m

OZZO TECHNOLOGY (HK) LIMITED

TRAFFIC SIGNAL CALCULATION

INITIALS

DATE

Proposed Minor Relaxation of Building Height Restriction for the Permitted Educational Institution (New Science Building) in "Government, Institution or Community" Zone at Lingnan University, No. 8 Castle Peak Road - Lingnan, Tuen Mun

PROJECT NO. 82904

Prepared By: LL

Jan-25

J1: Castle Peak Road - Lingnan / Castle Peak Road - Lam Tei

2031 Ref_PM

FILENAME :

Checked By: DP

Jan-25

2031 Reference Weekday PM Peak Hour Traffic Flows

Peak Road - Lam Tei_Castle Peak Road - Lingnan_S.xls

Reviewed By: OC

Jan-25

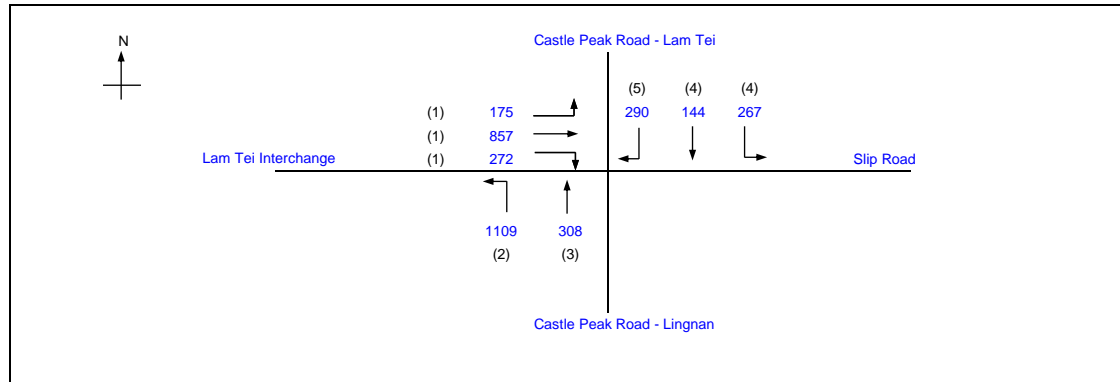

		Existing Cycle Time	
No. of stages per cycle	N =	3	
Cycle time	C =	110 sec	
Sum(y)	Y =	0.368	
Loss time	L =	16 sec	
Total Flow	=	2836 pcu	
Co = (1.5*L+5)/(1-Y)	=	45.9 sec	
Cm = L/(1-Y)	=	25.3 sec	
Yult =	=	0.780	
R.C.ult = (Yult-Y)/Y*100%	=	111.9 %	
Cp = 0.9*L/(0.9-Y)	=	27.1 sec	
Ymax = 1-L/C	=	0.855	
R.C.(C) = (0.9*Ymax-Y)/Y*100%	=	108.9 %	

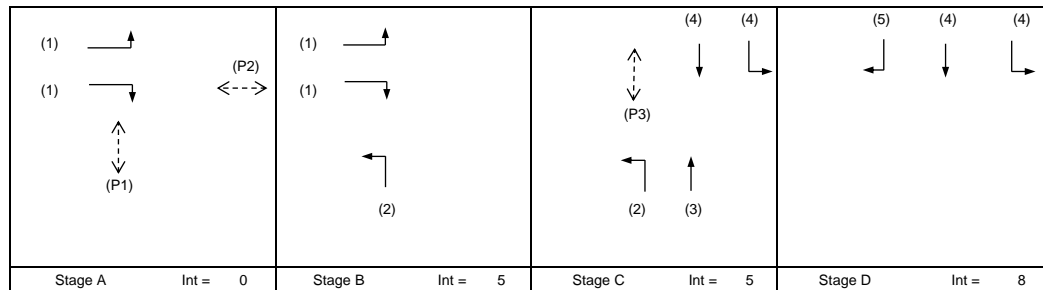

Pedestrian Phase	Stage	Length (m)	Green Time Required (s)			Green Time Provided (s)	
			SG	FG	Delay	SG	FG
P1	A	7	5	6	2	60	12
P2	A	7	5	6	14	26	16
P3	C	14	5	12	2	99	8

Move-ment	Stage	Lane Width m.	Phase	No. of lane	Radius m.	O	N	Straight-Ahead Sat. Flow	Movement			Total FFlow pcu/h	Proportion of Turning Vehicles	Sat. Flow pcu/h	Flare lane Length m.	Share Effect pcu/hr	Revised Sat. Flow pcu/h	y	Greater y	L sec	g (required) sec	g (input) sec	Degree of Saturation X	Queue Length (m / lane)	Average Delay (seconds)
									Left pcu/h	Straight pcu/h	Right pcu/h														
LT	A,B	3.40	1	1	15		N	1955	141			141	1.00	1777		1777	0.079		16	20	20	0.431	18	40	
LT,RT	A,B	3.30	1	1	34			2085	34		124	158	1.00	1997		1997	0.079			20	20	0.431	18	39	
RT	A,B	3.30	1	1	31		N	1945			147	147	1.00	1855		1855	0.079			20	20	0.431	18	39	
RT	A,B	3.30	1	1	31		N	1945			272	272	1.00	1855		1855	0.146			37	37	0.431	0	0	
LT	B,C	3.30	2	2	14			4170	1109			1109	1.00	3766		3766	0.294	0.294		75	75	0.431	30	8	
SA	C	3.30	3	2				4170		308		308	0.00	4170		4170	0.074			19	19	0.431	21	38	
LT	C,D	3.30	4	1	100		N	1945	267			267	1.00	1916		1916	0.139			36	36	0.431	30	28	
SA	C,D	3.50	4	1				2105		144		144	0.00	2105		2105	0.068			17	17	0.063	18	41	
SA,RT	C,D	3.50	5	1	43			2105		0	150	150	1.00	2034		2034	0.074			19	19	0.063	18	40	
RT	D	3.50	5	1	40		N	1965			140	140	1.00	1894		1894	0.074	0.074		19	19	0.063	18	40	

NOTE : O - OPPOSING TRAFFIC

N - NEAR SIDE LANE

SG - STEADY GREEN

FG - FLASHING GREEN

PEDESTRIAN WALKING SPEED = 1.2m/s

QUEUING LENGTH = AVERAGE QUEUE * 6m

OZZO TECHNOLOGY (HK) LIMITED

TRAFFIC SIGNAL CALCULATION

INITIALS

DATE

Proposed Minor Relaxation of Building Height Restriction for the Permitted Educational Institution (New Science Building) in "Government, Institution or Community" Zone at Lingnan University, No. 8 Castle Peak Road - Lingnan, Tuen Mun

PROJECT NO. 82904

Prepared By: LL

Jan-25

J1: Castle Peak Road - Lingnan / Castle Peak Road - Lam Tei

2031 Des_AM

FILENAME : Peak Road - Lam Tei_Castle Peak Road - Lingnan_S.xls

Checked By: DP

Jan-25

2031 Design Weekday AM Peak Hour Traffic Flows

Reviewed By: OC

Jan-25

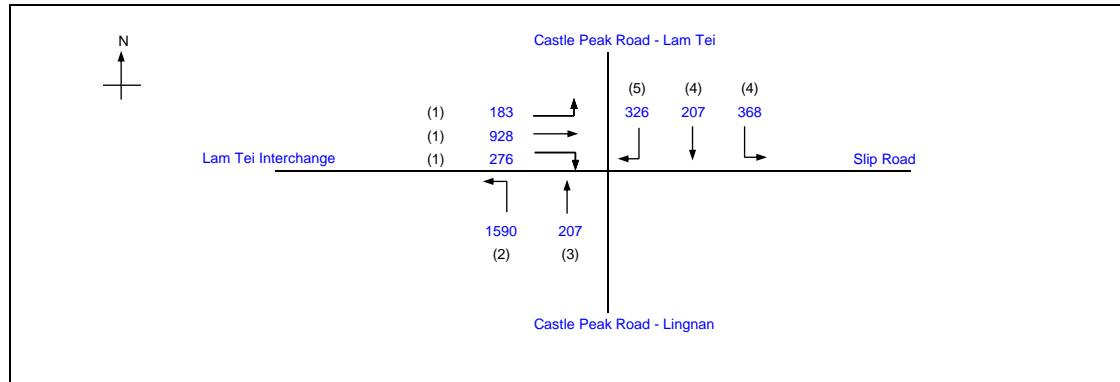

		Existing Cycle Time	
No. of stages per cycle	N =	3	
Cycle time	C =	110 sec	
Sum(y)	Y =	0.511	
Loss time	L =	16 sec	
Total Flow	=	3435 pcu	
Co	= $(1.5 \cdot L + 5) / (1 - Y)$	= 59.3 sec	
Cm	= $L / (1 - Y)$	= 32.7 sec	
Yult	=	0.780	
R.C.ult	= $(Yult - Y) / Y * 100\%$	= 52.8 %	
Cp	= $0.9 \cdot L / (0.9 - Y)$	= 37.0 sec	
Ymax	= 1 - L/C	= 0.855	
R.C.(C)	= $(0.9 \cdot Ymax - Y) / Y * 100\%$	= 50.6 %	

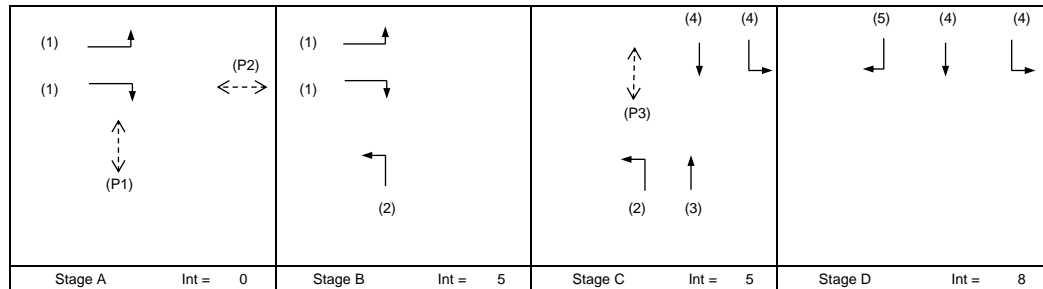

Pedestrian Phase	Stage	Length (m)	Green Time Required (s)			Green Time Provided (s)	
			SG	FG	Delay	SG	FG
P1	A	7	5	6	2	60	12
P2	A	7	5	6	14	26	16
P3	C	14	5	12	2	99	8

Move-ment	Stage	Lane Width m.	Phase	No. of lane	Radius m.	O	N	Straight-Ahead Sat. Flow	Movement			Total FFlow pcu/h	Proportion of Turning Vehicles	Sat. Flow pcu/h	Flare lane Length m.	Share Effect pcu/hr	Revised Sat. Flow pcu/h	y	Greater y	L sec	g (required) sec	g (input) sec	Degree of Saturation X	Queue Length (m / lane)	Average Delay (seconds)
									Left pcu/h	Straight pcu/h	Right pcu/h														
LT	A,B	3.40	1	1	15		N	1955	145			145	1.00	1777		1777	0.082		16	15	15	0.597	18	50	
LT,RT	A,B	3.30	1	1	34			2085	38		125	163	1.00	1997		1997	0.082			15	15	0.597	24	49	
RT	A,B	3.30	1	1	31		N	1945			151	151	1.00	1855		1855	0.082			15	15	0.597	24	50	
RT	A,B	3.30	1	1	31		N	1945			276	276	1.00	1855		1855	0.149			27	27	0.597	0	0	
LT	B,C	3.30	2	2	14			4170	1590			1590	1.00	3766		3766	0.422	0.422		78	78	0.597	42	8	
SA	C	3.30	3	2				4170		207		207	0.00	4170		4170	0.050			9	9	0.597	15	51	
LT	C,D	3.30	4	1	100		N	1945	368			368	1.00	1916		1916	0.192			35	35	0.597	42	32	
SA	C,D	3.50	4	1				2105		186		186	0.00	2105		2105	0.088			16	16	0.087	24	47	
SA,RT	C,D	3.50	5	1	43			2105		21	159	180	0.88	2042		2042	0.088			16	16	0.087	24	47	
RT	D	3.50	5	1	40		N	1965			167	167	1.00	1894		1894	0.088	0.088		16	16	0.087	24	48	

NOTE : O - OPPOSING TRAFFIC

N - NEAR SIDE LANE

SG - STEADY GREEN

FG - FLASHING GREEN

PEDESTRIAN WALKING SPEED = 1.2m/s

QUEUING LENGTH = AVERAGE QUEUE * 6m

OZZO TECHNOLOGY (HK) LIMITED

TRAFFIC SIGNAL CALCULATION

INITIALS

DATE

Proposed Minor Relaxation of Building Height Restriction for the Permitted Educational Institution (New Science Building) in "Government, Institution or Community" Zone at Lingnan University, No. 8 Castle Peak Road - Lingnan, Tuen Mun

PROJECT NO. 82904

Prepared By: LL

Jan-25

J1: Castle Peak Road - Lingnan / Castle Peak Road - Lam Tei

2031 Des_PM

FILENAME : Peak Road - Lam Tei_Castle Peak Road - Lingnan_S.xls

Checked By: DP

Jan-25

2031 Design Weekday PM Peak Hour Traffic Flows

Reviewed By: OC

Jan-25

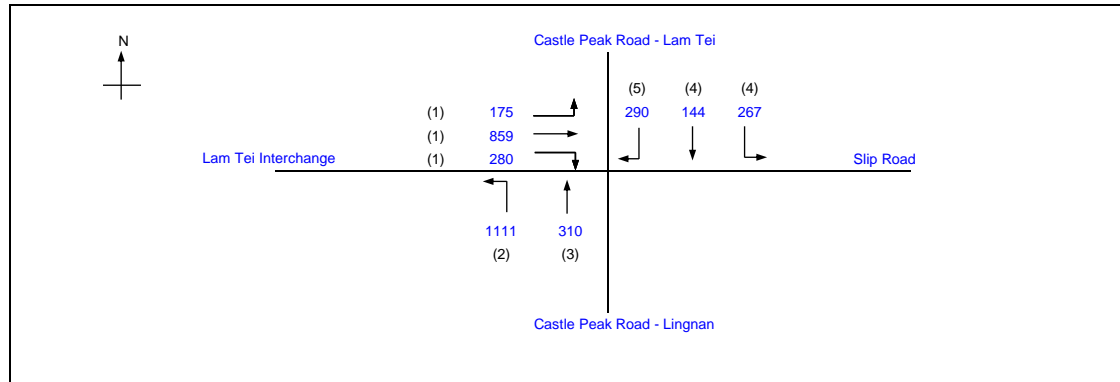

		Existing Cycle Time	
No. of stages per cycle	N =	3	
Cycle time	C =	110 sec	
Sum(y)	Y =	0.369	
Loss time	L =	16 sec	
Total Flow	=	2856 pcu	
Co	= (1.5*L+5)/(1-Y)	= 45.9 sec	
Cm	= L/(1-Y)	= 25.3 sec	
Yult	=	0.780	
R.C.ult	= (Yult-Y)/Y*100%	= 111.6 %	
Cp	= 0.9*L/(0.9-Y)	= 27.1 sec	
Ymax	= 1-L/C	= 0.855	
R.C.(C)	= (0.9*Ymax-Y)/Y*100%	= 108.6 %	

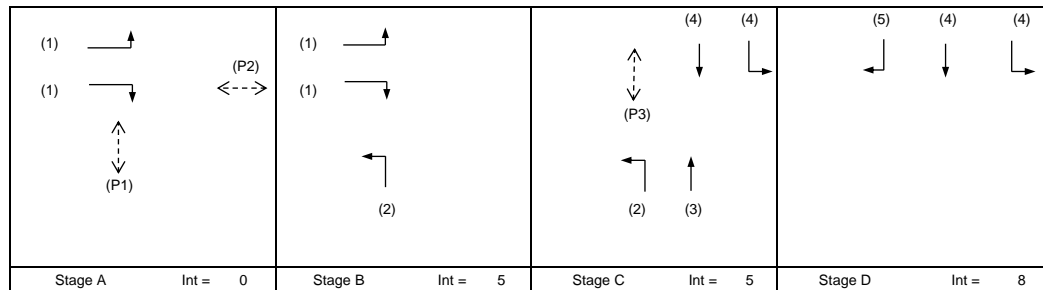

Pedestrian Phase	Stage	Length (m)	Green Time Required (s)			Green Time Provided (s)	
			SG	FG	Delay	SG	FG
P1	A	7	5	6	2	60	12
P2	A	7	5	6	14	26	16
P3	C	14	5	12	2	99	8

Move-ment	Stage	Lane Width m.	Phase	No. of lane	Radius m.	O	N	Straight-Ahead Sat. Flow	Movement			Total FFlow pcu/h	Proportion of Turning Vehicles	Sat. Flow pcu/h	Flare lane Length m.	Share Effect pcu/hr	Revised Sat. Flow pcu/h	y	Greater y	L sec	g (required) sec	g (input) sec	Degree of Saturation X	Queue Length (m / lane)	Average Delay (seconds)
									Left pcu/h	Straight pcu/h	Right pcu/h														
LT	A,B	3.40	1	1	15		N	1955	143			143	1.00	1777		1777	0.081		16	21	21	0.431	18	39	
LT,RT	A,B	3.30	1	1	34			2085	31		130	161	1.00	1997		1997	0.081			21	21	0.431	24	39	
RT	A,B	3.30	1	1	31		N	1945			150	150	1.00	1855		1855	0.081			21	21	0.431	18	39	
RT	A,B	3.30	1	1	31		N	1945			280	280	1.00	1855		1855	0.151			38	38	0.431	0	0	
LT	B,C	3.30	2	2	14			4170	1111			1111	1.00	3766		3766	0.295	0.295		75	75	0.431	30	8	
SA	C	3.30	3	2				4170		310		310	0.00	4170		4170	0.074			19	19	0.431	21	38	
LT	C,D	3.30	4	1	100		N	1945	267			267	1.00	1916		1916	0.139			36	36	0.431	30	28	
SA	C,D	3.50	4	1				2105		144		144	0.00	2105		2105	0.068			17	17	0.063	18	41	
SA,RT	C,D	3.50	5	1	43			2105		0	150	150	1.00	2034		2034	0.074			19	19	0.063	18	40	
RT	D	3.50	5	1	40		N	1965			140	140	1.00	1894		1894	0.074	0.074		19	19	0.063	18	41	

NOTE : O - OPPOSING TRAFFIC

N - NEAR SIDE LANE

SG - STEADY GREEN

FG - FLASHING GREEN

PEDESTRIAN WALKING SPEED = 1.2m/s

QUEUING LENGTH = AVERAGE QUEUE * 6m

OZZO TECHNOLOGY (HK) LIMITED	TRAFFIC SIGNAL CALCULATION		INITIALS	DATE
Proposed Minor Relaxation of Building Height Restriction for the Permitted Educational Institution (New Science Building) in "Government, Institution or Community" Zone at Lingnan University, No. 8 Castle Peak Road - Lingnan, Tuen Mun	PROJECT NO.: 82904	PREPARED BY: LL	LL	Jan/25
J2: Lam Tei Interchange	2031 Ref_AM	FILENAME : J2_Lam Tei Interchange_R.xls	CHECKED BY: DP	Jan/25
2031 Reference Weekday AM Peak Hour Traffic Flows			REVIEWED BY: OC	Jan/25

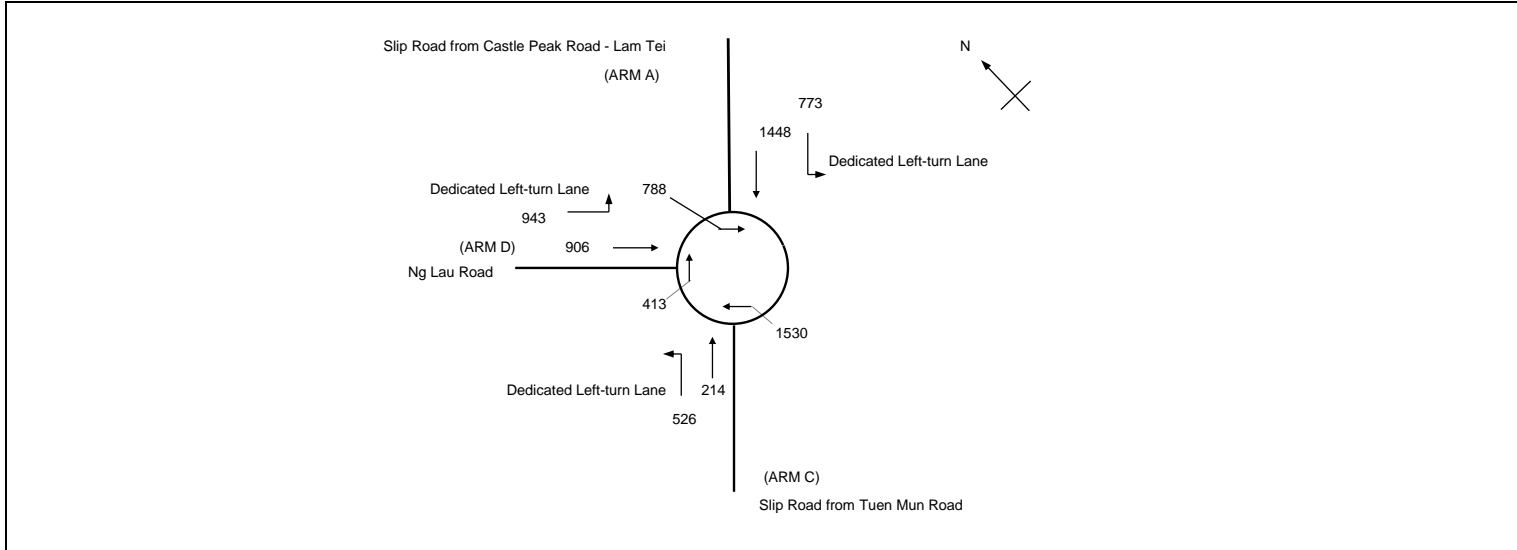

ARM	A	C	D		
INPUT PARAMETERS:					
V = Approach half width (m)	7.0	3.5	6.2		
E = Entry width (m)	7.2	3.7	7.2		
L = Effective length of flare (m)	4.0	18.0	9.1		
R = Entry radius (m)	33.0	77.2	67.5		
D = Inscribed circle diameter (m)	50.5	50.5	50.5		
A = Entry angle (degree)	19.0	20.0	15.0		
Q = Entry flow (pcu/h)	1448	214	906		
Qc = Circulating flow across entry (pcu/h)	788	1530	413		
OUTPUT PARAMETERS:					
S = Sharpness of flare = 1.6(E-V)/L	0.07	0.02	0.19		
K = 1-0.00347(A-30)-0.978(1/R-0.05)	1.06	1.07	1.09		
X2 = V + ((E-V)/(1+2S))	7.15	3.70	6.94		
M = EXP((D-60)/10)	0	0	0		
F = 303*X2	2166	1121	2102		
Td = 1+(0.5/(1+M))	1.36	1.36	1.36		
Fc = 0.21*Td(1+0.2*X2)	0.69	0.50	0.68		
Qe = K(F-Fc*Qc)	1712	386	1978	Total In Sum =	1667 PCU
DFC = Design flow/Capacity = Q/Qe	0.85	0.55	0.46	DFC of Critical Approach =	0.85

OZZO TECHNOLOGY (HK) LIMITED		TRAFFIC SIGNAL CALCULATION		INITIALS	DATE
Proposed Minor Relaxation of Building Height Restriction for the Permitted Educational Institution (New Science Building) in "Government, Institution or Community" Zone at Lingnan University, No. 8 Castle Peak Road - Lingnan, Tuen Mun		PROJECT NO.: 82904	PREPARED BY: LL	Jan/25	
J2: Lam Tei Interchange		2031 Ref_PM	FILENAME : J2_Lam Tei Interchange_R.xls	CHECKED BY: DP	Jan/25
2031 Reference Weekday PM Peak Hour Traffic Flows			REVIEWED BY: OC	Jan/25	

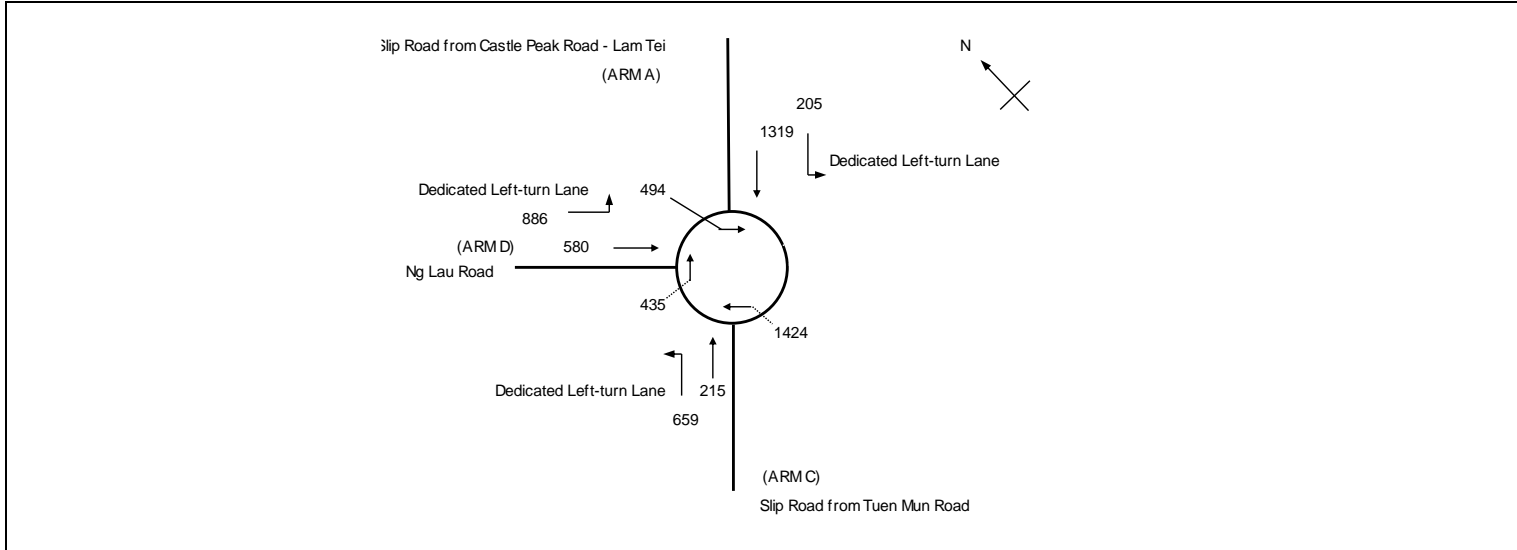

ARM	A	C	D		
INPUT PARAMETERS:					
V	= Approach half width (m)	7.0	3.5	6.2	
E	= Entry width (m)	7.2	3.7	7.2	
L	= Effective length of flare (m)	4.0	18.0	9.1	
R	= Entry radius (m)	33.0	77.2	67.5	
D	= Inscribed circle diameter (m)	50.5	50.5	50.5	
A	= Entry angle (degree)	19.0	20.0	15.0	
Q	= Entry flow (pcu/h)	1319	215	580	
Qc	= Circulating flow across entry (pcu/h)	494	1424	435	
OUTPUT PARAMETERS:					
S	= Sharpness of flare = 1.6(E-V)/L	0.07	0.02	0.19	
K	= 1-0.00347(A-30)-0.978(1/R-0.05)	1.06	1.07	1.09	
X2	= $V + ((E-V)/(1+2S))$	7.15	3.70	6.94	
M	= $EXP((D-60)/10)$	0	0	0	
F	= $303 * X2$	2166	1121	2102	
Td	= $1+(0.5/(1+M))$	1.36	1.36	1.36	
Fc	= $0.21 * Td(1+0.2 * X2)$	0.69	0.50	0.68	
Qe	= $K(F-Fc * Qc)$	1928	442	1962	
				Total In Sum =	1342 PCU
DFC	= Design flow/Capacity = Q/Qe	0.68	0.49	0.30	DFC of Critical Approach = 0.68

OZZO TECHNOLOGY (HK) LIMITED		TRAFFIC SIGNAL CALCULATION		INITIALS	DATE
Proposed Minor Relaxation of Building Height Restriction for the Permitted Educational Institution (New Science Building) in "Government, Institution or Community" Zone at Lingnan University, No. 8 Castle Peak Road - Lingnan, Tuen Mun		PROJECT NO.: 82904	PREPARED BY: LL	Jan/25	
J2: Lam Tei Interchange		2031 Des_AM	FILENAME : J2_Lam Tei Interchange_R.xls	CHECKED BY: DP	Jan/25
2031 Design Weekday AM Peak Hour Traffic Flows				REVIEWED BY: OC	Jan/25

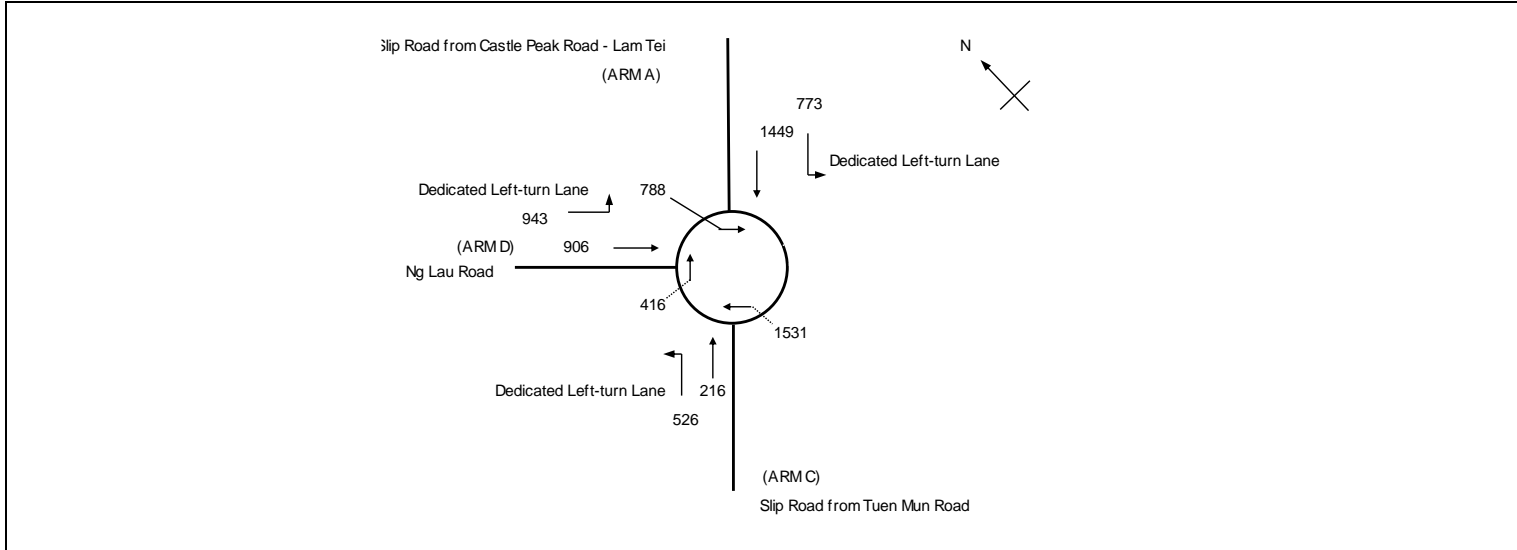

ARM	A	C	D		
INPUT PARAMETERS:					
V = Approach half width (m)	7.0	3.5	6.2		
E = Entry width (m)	7.2	3.7	7.2		
L = Effective length of flare (m)	4.0	18.0	9.1		
R = Entry radius (m)	33.0	77.2	67.5		
D = Inscribed circle diameter (m)	50.5	50.5	50.5		
A = Entry angle (degree)	19.0	20.0	15.0		
Q = Entry flow (pcu/h)	1449	216	906		
Qc = Circulating flow across entry (pcu/h)	788	1531	416		
OUTPUT PARAMETERS:					
S = Sharpness of flare = 1.6(E-V)/L	0.07	0.02	0.19		
K = 1-0.00347(A-30)-0.978(1/R-0.05)	1.06	1.07	1.09		
X2 = $V + ((E-V)/(1+2S))$	7.15	3.70	6.94		
M = $EXP((D-60)/10)$	0	0	0		
F = $303 * X2$	2166	1121	2102		
Td = $1+(0.5/(1+M))$	1.36	1.36	1.36		
Fc = $0.21 * Td(1+0.2 * X2)$	0.69	0.50	0.68		
Qe = $K(F-Fc * Qc)$	1712	386	1975	Total In Sum =	1669 PCU
DFC = Design flow/Capacity = Q/Qe	0.85	0.56	0.46	DFC of Critical Approach =	0.85

OZZO TECHNOLOGY (HK) LIMITED		TRAFFIC SIGNAL CALCULATION		INITIALS	DATE
Proposed Minor Relaxation of Building Height Restriction for the Permitted Educational Institution (New Science Building) in "Government, Institution or Community" Zone at Lingnan University, No. 8 Castle Peak Road - Lingnan, Tuen Mun		PROJECT NO.: 82904	PREPARED BY: LL	Jan/25	
J2: Lam Tei Interchange		FILENAME : J2_Lam Tei Interchange_R.xls	CHECKED BY: DP	Jan/25	
2031 Design Weekday PM Peak Hour Traffic Flows			REVIEWED BY: OC	Jan/25	

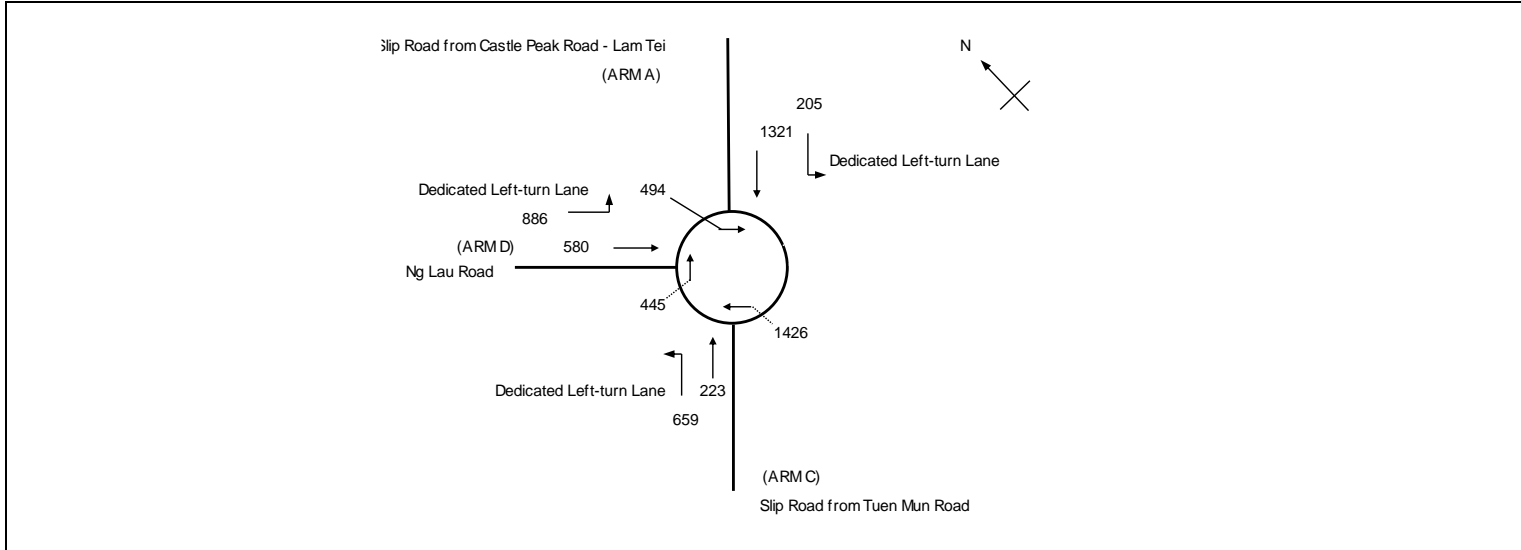

ARM	A	C	D		
INPUT PARAMETERS:					
V = Approach half width (m)	7.0	3.5	6.2		
E = Entry width (m)	7.2	3.7	7.2		
L = Effective length of flare (m)	4.0	18.0	9.1		
R = Entry radius (m)	33.0	77.2	67.5		
D = Inscribed circle diameter (m)	50.5	50.5	50.5		
A = Entry angle (degree)	19.0	20.0	15.0		
Q = Entry flow (pcu/h)	1321	223	580		
Qc = Circulating flow across entry (pcu/h)	494	1426	445		
OUTPUT PARAMETERS:					
S = Sharpness of flare = 1.6(E-V)/L	0.07	0.02	0.19		
K = 1-0.00347(A-30)-0.978(1/R-0.05)	1.06	1.07	1.09		
X2 = $V + ((E-V)/(1+2S))$	7.15	3.70	6.94		
M = $EXP((D-60)/10)$	0	0	0		
F = $303 * X2$	2166	1121	2102		
Td = $1+(0.5/(1+M))$	1.36	1.36	1.36		
Fc = $0.21 * Td(1+0.2 * X2)$	0.69	0.50	0.68		
Qe = $K(F-Fc * Qc)$	1928	441	1954	Total In Sum =	1350 PCU
DFC = Design flow/Capacity = Q/Qe	0.69	0.51	0.30	DFC of Critical Approach =	0.69

OZZO TECHNOLOGY (HK) LIMITED	PRIORITY JUNCTION CALCULATION	INITIALS	DATE
-------------------------------------	--------------------------------------	----------	------

Proposed Minor Relaxation of Building Height Restriction for the Permitted Educational Institution (New Science Building) in "Government, Institution or Community" Zone at Lingnan University, No. 8 Castle Peak Road - Lingnan, Tuen Mun	PROJECT NO.: 82904	PREPARED BY: LL	Jan-25
--	--------------------	-----------------	--------

J3 : Tuen Kwai Road / Northern Access of Lingnan University	2031 Ref_AM	FILENAME :	CHECKED BY: DP	Jan-25
2031 Reference Weekday AM Peak Hour Traffic Flows		3_Tuen Kwai Road_Northern Access of Lingnan University_P.xls	REVIEWED BY: OC	Jan-25

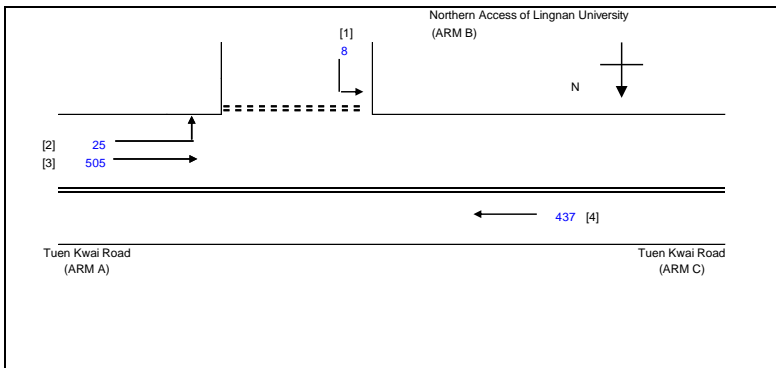

- NOTES : (GEOMETRIC INPUT DATA)
- W = MAJOR ROAD WIDTH
 - W cr = CENTRAL RESERVE WIDTH
 - W b-a = LANE WIDTH AVAILABLE TO VEHICLE WAITING IN STREAM b-a
 - W b-c = LANE WIDTH AVAILABLE TO VEHICLE WAITING IN STREAM b-c
 - W c-b = LANE WIDTH AVAILABLE TO VEHICLE WAITING IN STREAM c-b
 - Vi b-a = VISIBILITY TO THE LEFT FOR VEHICLES WAITING IN STREAM b-a
 - Vr b-a = VISIBILITY TO THE RIGHT FOR VEHICLES WAITING IN STREAM b-a
 - Vr b-c = VISIBILITY TO THE RIGHT FOR VEHICLES WAITING IN STREAM b-c
 - Vr c-b = VISIBILITY TO THE RIGHT FOR VEHICLES WAITING IN STREAM c-b
 - D = STREAM-SPECIFIC B-A
 - E = STREAM-SPECIFIC B-C
 - F = STREAM-SPECIFIC C-B
 - Y = (1-0.0345W)

GEOMETRIC DETAILS:

MAJOR ROAD (ARM A)

W = 10.05 (metres)

W cr = 2.5 (metres)

q a-b = 25 (pcu/hr)

q a-c = 505 (pcu/hr)

MAJOR ROAD (ARM C)

W c-b = 2.82 (metres)

Vr c-b = 20 (metres)

q c-a = 437.04 (pcu/hr)

q c-b = (pcu/hr)

MINOR ROAD (ARM B)

W b-a = (metres)

W b-c = 7.42 (metres)

Vi b-a = 78 (metres)

Vr b-a = 85 (metres)

Vr b-c = 85 (metres)

q b-a = (pcu/hr)

q b-c = 8 (pcu/hr)

GEOMETRIC FACTORS :

D = 0.60872348

E = 1.312020493

F = 0.8390018

Y = 0.6534475

THE CAPACITY OF MOVEMENT :

Q b-a = 289

Q b-c = 817

Q c-b = 519

Q b-c (O) = 817

TOTAL FLOW = 537.810665 (PCU/HR)

COMPARISON OF DESIGN FLOW TO CAPACITY:

DFC b-a = 0.0000

DFC b-c = 0.0097

DFC c-b = 0.0000

CRITICAL DFC = 0.01

OZZO TECHNOLOGY (HK) LIMITED	PRIORITY JUNCTION CALCULATION	INITIALS	DATE
-------------------------------------	--------------------------------------	----------	------

Proposed Minor Relaxation of Building Height Restriction for the Permitted Educational Institution (New Science Building) in "Government, Institution or Community" Zone at Lingnan University, No. 8 Castle Peak Road - Lingnan, Tuen Mun	PROJECT NO.: 82904	PREPARED BY: LL	Jan-25
--	--------------------	-----------------	--------

J3 : Tuen Kwai Road / Northern Access of Lingnan University	2031 Ref_PM	FILENAME :	CHECKED BY: DP	Jan-25
2031 Reference Weekday PM Peak Hour Traffic Flows		3_Tuen Kwai Road_Northern Access of Lingnan University_P.xls	REVIEWED BY: OC	Jan-25

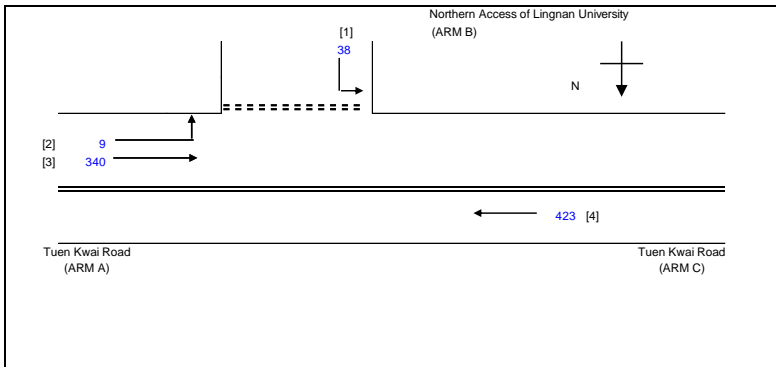

NOTES : (GEOMETRIC INPUT DATA)

- W = MAJOR ROAD WIDTH
- W cr = CENTRAL RESERVE WIDTH
- W b-a = LANE WIDTH AVAILABLE TO VEHICLE WAITING IN STREAM b-a
- W b-c = LANE WIDTH AVAILABLE TO VEHICLE WAITING IN STREAM b-c
- W c-b = LANE WIDTH AVAILABLE TO VEHICLE WAITING IN STREAM c-b
- Vi b-a = VISIBILITY TO THE LEFT FOR VEHICLES WAITING IN STREAM b-a
- Vr b-a = VISIBILITY TO THE RIGHT FOR VEHICLES WAITING IN STREAM b-a
- Vr b-c = VISIBILITY TO THE RIGHT FOR VEHICLES WAITING IN STREAM b-c
- Vr c-b = VISIBILITY TO THE RIGHT FOR VEHICLES WAITING IN STREAM c-b
- D = STREAM-SPECIFIC B-A
- E = STREAM-SPECIFIC B-C
- F = STREAM-SPECIFIC C-B
- Y = (1-0.0345W)

<p>GEOMETRIC DETAILS:</p> <p>MAJOR ROAD (ARM A)</p> <p>W = 10.05 (metres)</p> <p>W cr = 2.5 (metres)</p> <p>q a-b = 9 (pcu/hr)</p> <p>q a-c = 340 (pcu/hr)</p> <p>MAJOR ROAD (ARM C)</p> <p>W c-b = 2.82 (metres)</p> <p>Vr c-b = 20 (metres)</p> <p>q c-a = 423.46 (pcu/hr)</p> <p>q c-b = (pcu/hr)</p> <p>MINOR ROAD (ARM B)</p> <p>W b-a = (metres)</p> <p>W b-c = 7.42 (metres)</p> <p>Vi b-a = 78 (metres)</p> <p>Vr b-a = 85 (metres)</p> <p>Vr b-c = 85 (metres)</p> <p>q b-a = (pcu/hr)</p> <p>q b-c = 38 (pcu/hr)</p>	<p>GEOMETRIC FACTORS :</p> <p>D = 0.60872348</p> <p>E = 1.312020493</p> <p>F = 0.8390018</p> <p>Y = 0.6534475</p>	<p>THE CAPACITY OF MOVEMENT :</p> <p>Q b-a = 315</p> <p>Q b-c = 870</p> <p>Q c-b = 555</p> <p>Q b-c (O) = 870</p> <p>TOTAL FLOW = 387.2236788 (PCU/HR)</p>	<p>COMPARISON OF DESIGN FLOW TO CAPACITY:</p> <p>DFC b-a = 0.0000</p> <p>DFC b-c = 0.0442</p> <p>DFC c-b = 0.0000</p> <p>CRITICAL DFC = 0.04</p>
--	--	---	--

OZZO TECHNOLOGY (HK) LIMITED	PRIORITY JUNCTION CALCULATION	INITIALS	DATE
-------------------------------------	--------------------------------------	----------	------

Proposed Minor Relaxation of Building Height Restriction for the Permitted Educational Institution (New Science Building) in "Government, Institution or Community" Zone at Lingnan University, No. 8 Castle Peak Road - Lingnan, Tuen Mun	PROJECT NO.: 82904	PREPARED BY: LL	Jan-25
--	--------------------	-----------------	--------

J3 : Tuen Kwai Road / Northern Access of Lingnan University	2031 Des_AM	FILENAME :	CHECKED BY: DP	Jan-25
2031 Design Weekday AM Peak Hour Traffic Flows		3_Tuen Kwai Road_Northern Access of Lingnan University_P.xls	REVIEWED BY: OC	Jan-25

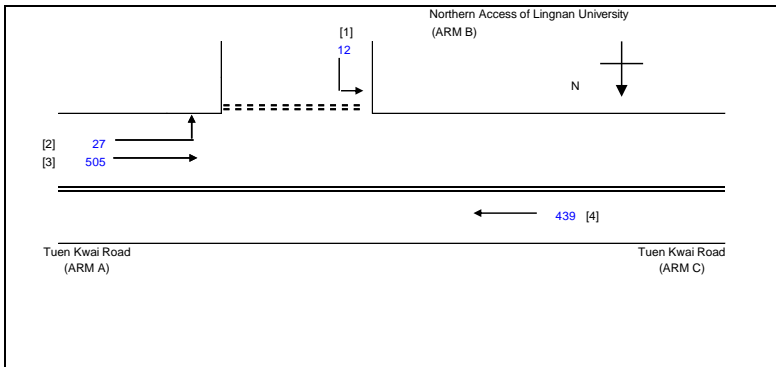

NOTES : (GEOMETRIC INPUT DATA)

- W = MAJOR ROAD WIDTH
- W cr = CENTRAL RESERVE WIDTH
- W b-a = LANE WIDTH AVAILABLE TO VEHICLE WAITING IN STREAM b-a
- W b-c = LANE WIDTH AVAILABLE TO VEHICLE WAITING IN STREAM b-c
- W c-b = LANE WIDTH AVAILABLE TO VEHICLE WAITING IN STREAM c-b
- Vi b-a = VISIBILITY TO THE LEFT FOR VEHICLES WAITING IN STREAM b-a
- Vr b-a = VISIBILITY TO THE RIGHT FOR VEHICLES WAITING IN STREAM b-a
- Vr b-c = VISIBILITY TO THE RIGHT FOR VEHICLES WAITING IN STREAM b-c
- Vr c-b = VISIBILITY TO THE RIGHT FOR VEHICLES WAITING IN STREAM c-b
- D = STREAM-SPECIFIC B-A
- E = STREAM-SPECIFIC B-C
- F = STREAM-SPECIFIC C-B
- Y = (1-0.0345W)

GEOMETRIC DETAILS:	GEOMETRIC FACTORS :	THE CAPACITY OF MOVEMENT :	COMPARISON OF DESIGN FLOW TO CAPACITY:
MAJOR ROAD (ARM A) W = 10.05 (metres) W cr = 2.5 (metres) q a-b = 27 (pcu/hr) q a-c = 505 (pcu/hr)	D = 0.60872348 E = 1.312020493 F = 0.8390018 Y = 0.6534475	Q b-a = 288 Q b-c = 817 Q c-b = 519 TOTAL FLOW = 543.810665 (PCU/HR)	DFC b-a = 0.0000 DFC b-c = 0.0146 DFC c-b = 0.0000
MAJOR ROAD (ARM C) W c-b = 2.82 (metres) Vr c-b = 20 (metres) q c-a = 439.04 (pcu/hr) q c-b = (pcu/hr)			
MINOR ROAD (ARM B) W b-a = (metres) W b-c = 7.42 (metres) Vi b-a = 78 (metres) Vr b-a = 85 (metres) Vr b-c = 85 (metres) q b-a = (pcu/hr) q b-c = 12 (pcu/hr)			CRITICAL DFC = 0.01

OZZO TECHNOLOGY (HK) LIMITED	PRIORITY JUNCTION CALCULATION	INITIALS	DATE
-------------------------------------	--------------------------------------	----------	------

Proposed Minor Relaxation of Building Height Restriction for the Permitted Educational Institution (New Science Building) in "Government, Institution or Community" Zone at Lingnan University, No. 8 Castle Peak Road - Lingnan, Tuen Mun	PROJECT NO.: 82904	PREPARED BY: LL	Jan-25
--	--------------------	-----------------	--------

J3 : Tuen Kwai Road / Northern Access of Lingnan University	2031 Des_PM	FILENAME : 3_Tuen Kwai Road_Northern Access of Lingnan University_P.xls	CHECKED BY: DP	Jan-25
2031 Design Weekday PM Peak Hour Traffic Flows			REVIEWED BY: OC	Jan-25

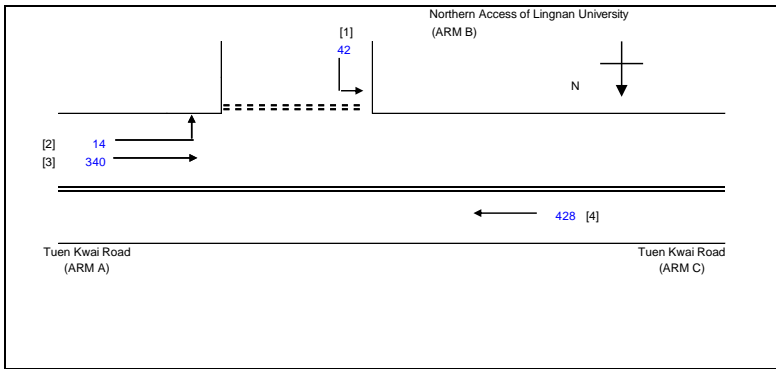

NOTES : (GEOMETRIC INPUT DATA)

- W = MAJOR ROAD WIDTH
- W cr = CENTRAL RESERVE WIDTH
- W b-a = LANE WIDTH AVAILABLE TO VEHICLE WAITING IN STREAM b-a
- W b-c = LANE WIDTH AVAILABLE TO VEHICLE WAITING IN STREAM b-c
- W c-b = LANE WIDTH AVAILABLE TO VEHICLE WAITING IN STREAM c-b
- Vi b-a = VISIBILITY TO THE LEFT FOR VEHICLES WAITING IN STREAM b-a
- Vr b-a = VISIBILITY TO THE RIGHT FOR VEHICLES WAITING IN STREAM b-a
- Vr b-c = VISIBILITY TO THE RIGHT FOR VEHICLES WAITING IN STREAM b-c
- Vr c-b = VISIBILITY TO THE RIGHT FOR VEHICLES WAITING IN STREAM c-b
- D = STREAM-SPECIFIC B-A
- E = STREAM-SPECIFIC B-C
- F = STREAM-SPECIFIC C-B
- Y = (1-0.0345W)

GEOMETRIC DETAILS:	GEOMETRIC FACTORS :	THE CAPACITY OF MOVEMENT :	COMPARISON OF DESIGN FLOW TO CAPACITY:
MAJOR ROAD (ARM A) W = 10.05 (metres) W cr = 2.5 (metres) q a-b = 14 (pcu/hr) q a-c = 340 (pcu/hr)	D = 0.60872348 E = 1.312020493 F = 0.8390018 Y = 0.6534475	Q b-a = 314 Q b-c = 870 Q c-b = 554 Q b-c (O) = 870	DFC b-a = 0.0000 DFC b-c = 0.0488 DFC c-b = 0.0000
MAJOR ROAD (ARM C) W c-b = 2.82 (metres) Vr c-b = 20 (metres) q c-a = 428.46 (pcu/hr) q c-b = (pcu/hr)		TOTAL FLOW = 396.2236788 (PCU/HR)	
MINOR ROAD (ARM B) W b-a = (metres) W b-c = 7.42 (metres) Vi b-a = 78 (metres) Vr b-a = 85 (metres) Vr b-c = 85 (metres) q b-a = (pcu/hr) q b-c = 42 (pcu/hr)			CRITICAL DFC = 0.05

Proposed Minor Relaxation of Building Height Restriction for the Permitted Educational Institution (New Science Building) in "Government, Institution or Community" Zone at Lingnan University, No. 8 Castle Peak Road - Lingnan, Tuen Mun

PROJECT NO. 82904

Prepared By: LL

Jan-25

J4: Castle Peak Road - Lingnan / Tuen Fu Road / Tuen Kwai Road

2031 Ref_AM

FILENAME :

Checked By: DP

Jan-25

2031 Reference Weekday AM Peak Hour Traffic Flows

J4_Castle Peak Road - Lingnan_Tuen Fu Road_Tuen Kwa

Reviewed By: OC

Jan-25

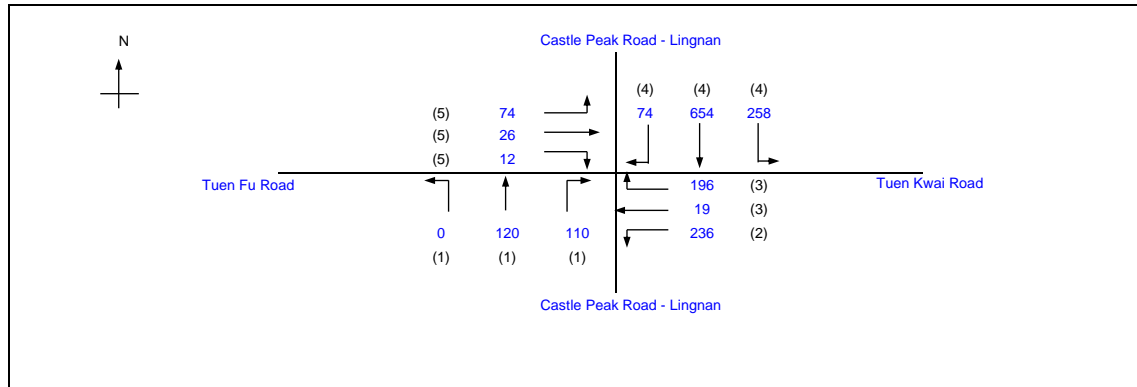

		Existing Cycle Time	
No. of stages per cycle	N =	4	
Cycle time	C =	120 sec	
Sum(y)	Y =	0.402	
Loss time	L =	20 sec	
Total Flow	=	1778 pcu	
Co = (1.5*L+5)/(1-Y)	=	58.6 sec	
Cm = L/(1-Y)	=	33.5 sec	
Yult	=	0.750	
R.C.ult = (Yult-Y)/Y*100%	=	86.4 %	
Cp = 0.9*L/(0.9-Y)	=	36.2 sec	
Ymax = 1-L/C	=	0.833	
R.C.(C) = (0.9*Ymax-Y)/Y*100%	=	86.4 %	

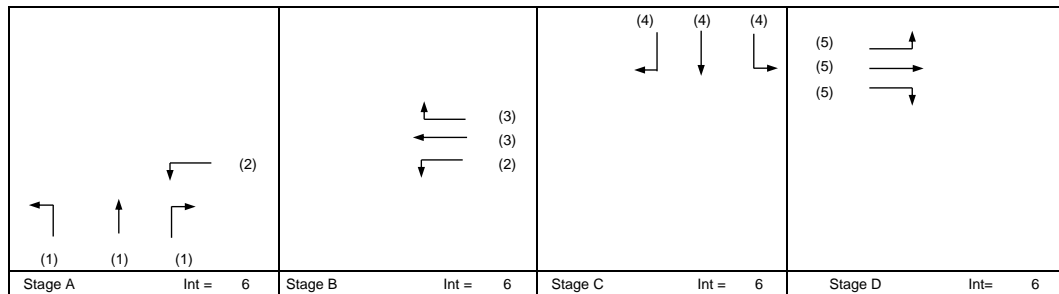

Pedestrian Phase	Stage	Length (m)	Green Time Required (s)			Green Time Provided (s)	
			SG	FG	Delay	SG	FG

Movement	Stage	Lane Width m.	Phase	No. of lane	Radius m.	O	N	Straight-Ahead Sat. Flow	Movement			Total FLOW pcu/h	Proportion of Turning Vehicles	Sat. Flow pcu/h	Flare lane Length m.	Share Effect pcu/hr	Revised Sat. Flow pcu/h	y	Greater y	L sec	g (required) sec	g (input) sec	Degree of Saturation X	Queue Length (m / lane)	Average Delay (seconds)
									Left pcu/h	Straight pcu/h	Right pcu/h														
LT,SA	A	3.58	1	1	9			2113	0	60		60	0.00	2113			2113	0.028		20	7	19	0.030	6	40
SA	A	3.53	1	1				2108		60		60	0.00	2108			2108	0.028			7	19	0.030	0	0
RT	A	3.69	1	1	18			2124			110	110	1.00	1961			1961	0.056	0.056		14	19	0.059	18	43
LT	A,B	3.25	2	1	25			2080	236			236	1.00	1962			1962	0.120			30	60	0.040	18	16
SA, RT	B	3.50	3	1	12			2105		19	196	215	0.91	1890			1890	0.114	0.114		28	36	0.063	30	32
LT,SA	C	3.70	4	1	11			2125	74	286		360	0.20	2067			2067	0.174			43	31	0.112	48	42
SA	C	3.59	4	1				2114		368		368	0.00	2114			2114	0.174	0.174		43	31	0.112	0	0
RT	C	3.59	4	1	17			2114			258	258	1.00	1943			1943	0.133			33	31	0.086	36	38
LT,SA,RT	D	3.46	5	1	12			2101	74	26	12	112	0.77	1917			1917	0.058	0.058		15	14	0.084	18	52

NOTE : O - OPPOSING TRAFFIC N - NEAR SIDE LANE SG - STEADY GREEN FG - FLASHING GREEN PEDESTRIAN WALKING SPEED = 1.2m/s QUEUING LENGTH = AVERAGE QUEUE * 6m

Proposed Minor Relaxation of Building Height Restriction for the Permitted Educational Institution (New Science Building) in "Government, Institution or Community" Zone at Lingnan University, No. 8 Castle Peak Road - Lingnan, Tuen Mun

PROJECT NO. 82904

Prepared By: LL

Jan-25

J4: Castle Peak Road - Lingnan / Tuen Fu Road / Tuen Kwai Road

2031 Ref_PM

FILENAME :

Checked By: DP

Jan-25

2031 Reference Weekday PM Peak Hour Traffic Flows

J4_Castle Peak Road - Lingnan_Tuen Fu Road_Tuen Kwa

Reviewed By: SC

Jan-25

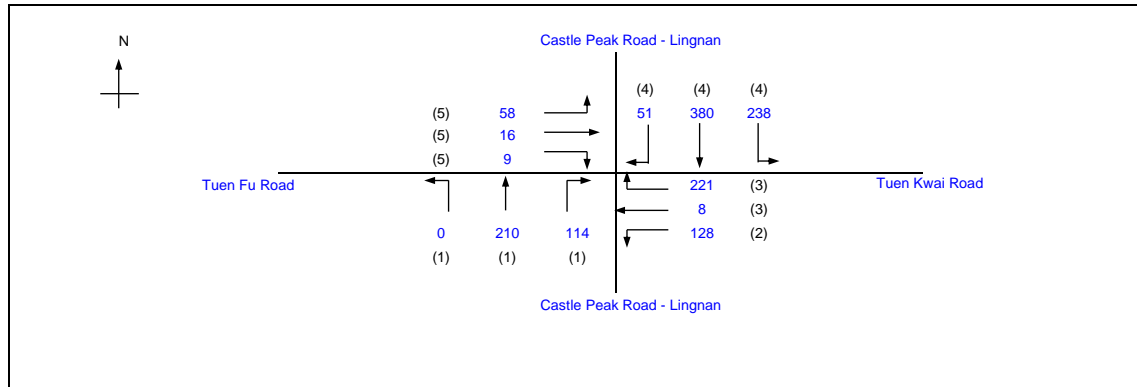

		Existing Cycle Time	
No. of stages per cycle	N =	4	
Cycle time	C =	110 sec	
Sum(y)	Y =	0.346	
Loss time	L =	20 sec	
Total Flow	=	1433 pcu	
Co = (1.5*L+5)/(1-Y)	=	53.5 sec	
Cm = L/(1-Y)	=	30.6 sec	
Yult	=	0.750	
R.C.ult = (Yult-Y)/Y*100%	=	116.9 %	
Cp = 0.9*L/(0.9-Y)	=	32.5 sec	
Ymax = 1-L/C	=	0.818	
R.C.(C) = (0.9*Ymax-Y)/Y*100%	=	112.9 %	

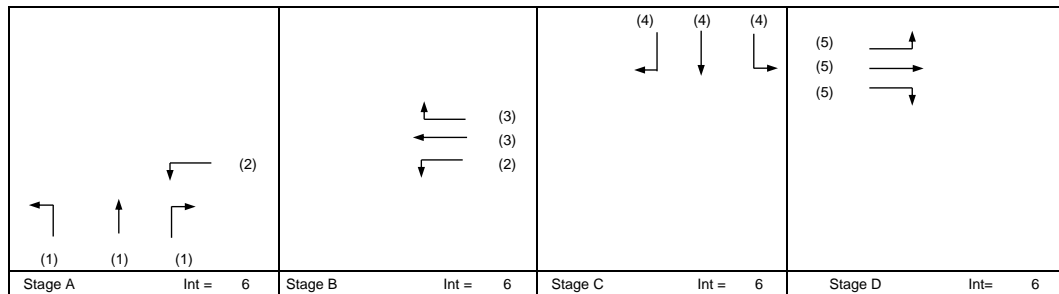

Pedestrian Phase	Stage	Length (m)	Green Time Required (s)			Green Time Provided (s)	
			SG	FG	Delay	SG	FG

Movement	Stage	Lane Width m.	Phase	No. of lane	Radius m.	O	N	Straight-Ahead Sat. Flow	Movement			Total FLOW pcu/h	Proportion of Turning Vehicles	Sat. Flow pcu/h	Flare lane Length m.	Share Effect pcu/hr	Revised Sat. Flow pcu/h	y	Greater y	L sec	g (required) sec	g (input) sec	Degree of Saturation X	Queue Length (m / lane)	Average Delay (seconds)
									Left pcu/h	Straight pcu/h	Right pcu/h														
LT,SA	A	3.58	1	1	9			2113	0	105		105	0.00	2113			2113	0.050		20	13	24	0.042	12	33
SA	A	3.53	1	1				2108		105		105	0.00	2108			2108	0.050			13	24	0.042	0	0
RT	A	3.69	1	1	18			2124			114	114	1.00	1961			1961	0.058	0.058		15	24	0.049	12	34
LT	A,B	3.25	2	1	25			2080	128			128	1.00	1962			1962	0.065			17	50	0.026	12	16
SA, RT	B	3.50	3	1	12			2105		8	221	229	0.97	1878			1878	0.122	0.122		32	21	0.116	30	45
LT,SA	C	3.70	4	1	11			2125	51	162		213	0.24	2058			2058	0.103			27	31	0.067	24	30
SA	C	3.59	4	1				2114		219		219	0.00	2114			2114	0.103			27	31	0.067	0	0
RT	C	3.59	4	1	17			2114			238	238	1.00	1943			1943	0.122	0.122		32	31	0.079	30	31
LT,SA,RT	D	3.46	5	1	12			2101	58	16	9	83	0.81	1908			1908	0.043	0.043		11	14	0.062	12	43

NOTE : O - OPPOSING TRAFFIC N - NEAR SIDE LANE SG - STEADY GREEN FG - FLASHING GREEN PEDESTRIAN WALKING SPEED = 1.2m/s QUEUING LENGTH = AVERAGE QUEUE * 6m

Proposed Minor Relaxation of Building Height Restriction for the Permitted Educational Institution (New Science Building) in "Government, Institution or Community" Zone at Lingnan University, No. 8 Castle Peak Road - Lingnan, Tuen Mun

PROJECT NO. 82904

Prepared By: LL

Jan-25

J4: Castle Peak Road - Lingnan / Tuen Fu Road / Tuen Kwai Road

2031 Des_AM

FILENAME :

Checked By: DP

Jan-25

2031 Design Weekday AM Peak Hour Traffic Flows

J4_Castle Peak Road - Lingnan_Tuen Fu Road_Tuen Kwa

Reviewed By: OC

Jan-25

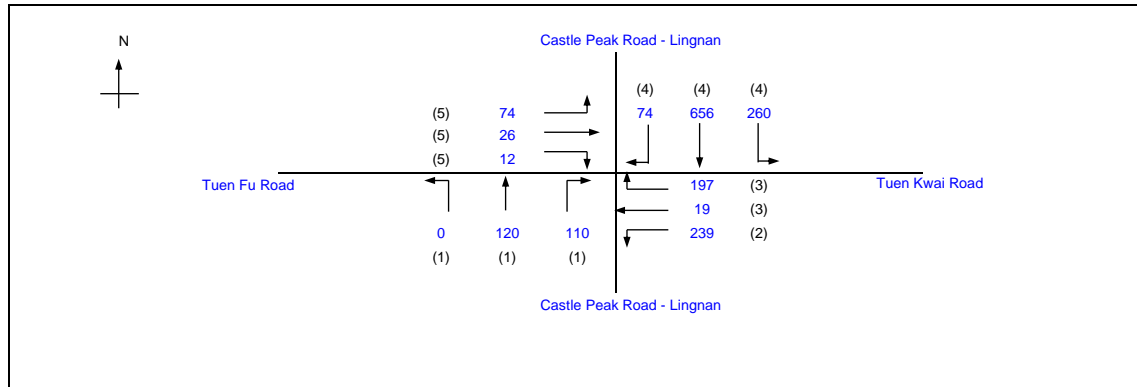

		Existing Cycle Time	
No. of stages per cycle	N =	4	
Cycle time	C =	120 sec	
Sum(y)	Y =	0.405	
Loss time	L =	20 sec	
Total Flow	=	1788 pcu	
Co = (1.5*L+5)/(1-Y)	=	58.8 sec	
Cm = L/(1-Y)	=	33.6 sec	
Yult	=	0.750	
R.C.ult = (Yult-Y)/Y*100%	=	85.2 %	
Cp = 0.9*L/(0.9-Y)	=	36.4 sec	
Ymax = 1-L/C	=	0.833	
R.C.(C) = (0.9*Ymax-Y)/Y*100%	=	85.2 %	

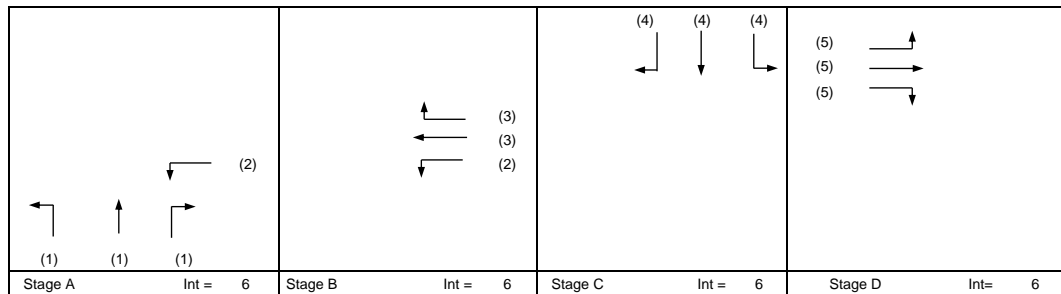

Pedestrian Phase	Stage	Length (m)	Green Time Required (s)			Green Time Provided (s)	
			SG	FG	Delay	SG	FG

Movement	Stage	Lane Width m.	Phase	No. of lane	Radius m.	O	N	Straight-Ahead Sat. Flow	Movement			Total FLOW pcu/h	Proportion of Turning Vehicles	Sat. Flow pcu/h	Flare lane Length m.	Share Effect pcu/hr	Revised Sat. Flow pcu/h	y	Greater y	L sec	g (required) sec	g (input) sec	Degree of Saturation X	Queue Length (m / lane)	Average Delay (seconds)
									Left pcu/h	Straight pcu/h	Right pcu/h														
LT,SA	A	3.58	1	1	9			2113	0	61		61	0.00	2113			2113	0.029		20	7	19	0.030	6	40
SA	A	3.53	1	1				2108		61		61	0.00	2108			2108	0.029			7	19	0.030	0	0
RT	A	3.69	1	1	18			2124			110	110	1.00	1961			1961	0.056	0.056		14	19	0.059	18	43
LT	A,B	3.25	2	1	25			2080	236			236	1.00	1962			1962	0.120			30	60	0.040	18	16
SA, RT	B	3.50	3	1	12			2105		19	200	219	0.91	1890			1890	0.116	0.116		29	36	0.064	30	32
LT,SA	C	3.70	4	1	11			2125	74	287		361	0.20	2067			2067	0.174			43	31	0.113	48	42
SA	C	3.59	4	1				2114		369		369	0.00	2114			2114	0.174	0.174		43	31	0.113	0	0
RT	C	3.59	4	1	17			2114			260	260	1.00	1943			1943	0.134			33	31	0.086	36	38
LT,SA,RT	D	3.46	5	1	12			2101	74	26	12	112	0.77	1917			1917	0.058	0.058		14	14	0.084	18	52

NOTE : O - OPPOSING TRAFFIC N - NEAR SIDE LANE SG - STEADY GREEN FG - FLASHING GREEN PEDESTRIAN WALKING SPEED = 1.2m/s QUEUING LENGTH = AVERAGE QUEUE * 6m

Proposed Minor Relaxation of Building Height Restriction for the Permitted Educational Institution (New Science Building) in "Government, Institution or Community" Zone at Lingnan University, No. 8 Castle Peak Road - Lingnan, Tuen Mun

PROJECT NO. 82904

Prepared By: LL

Jan-25

J4: Castle Peak Road - Lingnan / Tuen Fu Road / Tuen Kwai Road

2031 Des_PM

FILENAME :

Checked By: DP

Jan-25

2031 Design Weekday PM Peak Hour Traffic Flows

J4_Castle Peak Road - Lingnan_Tuen Fu Road_Tuen Kwa

Reviewed By: SC

Jan-25

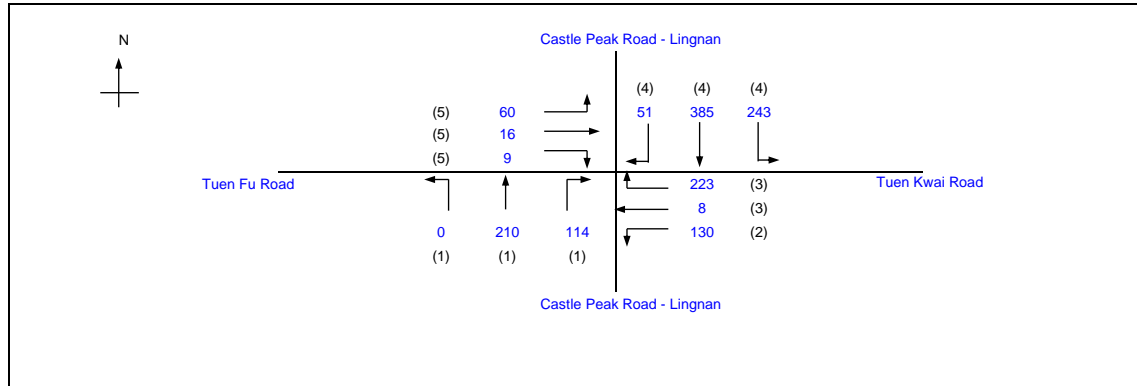

		Existing Cycle Time	
No. of stages per cycle	N =	4	
Cycle time	C =	110 sec	
Sum(y)	Y =	0.351	
Loss time	L =	20 sec	
Total Flow	=	1450 pcu	
Co = (1.5*L+5)/(1-Y)	=	53.9 sec	
Cm = L/(1-Y)	=	30.8 sec	
Yult	=	0.750	
R.C.ult = (Yult-Y)/Y*100%	=	114.0 %	
Cp = 0.9*L/(0.9-Y)	=	32.8 sec	
Ymax = 1-L/C	=	0.818	
R.C.(C) = (0.9*Ymax-Y)/Y*100%	=	110.1 %	

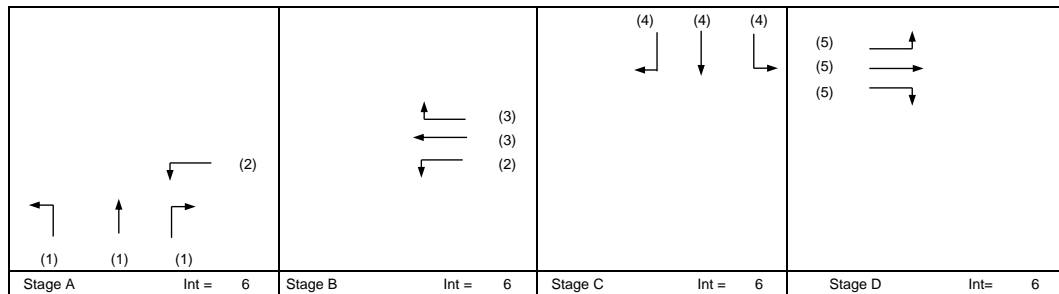

Pedestrian Phase	Stage	Length (m)	Green Time Required (s)			Green Time Provided (s)	
			SG	FG	Delay	SG	FG

Movement	Stage	Lane Width m.	Phase	No. of lane	Radius m.	O	N	Straight-Ahead Sat. Flow	Movement			Total FLOW pcu/h	Proportion of Turning Vehicles	Sat. Flow pcu/h	Flare lane Length m.	Share Effect pcu/hr	Revised Sat. Flow pcu/h	y	Greater y	L sec	g (required) sec	g (input) sec	Degree of Saturation X	Queue Length (m / lane)	Average Delay (seconds)
									Left pcu/h	Straight pcu/h	Right pcu/h														
LT,SA	A	3.58	1	1	9			2113	0	107		107	0.00	2113			2113	0.051		20	13	24	0.042	12	33
SA	A	3.53	1	1				2108		107		107	0.00	2108			2108	0.051			13	24	0.042	0	0
RT	A	3.69	1	1	18			2124			114	114	1.00	1961			1961	0.058	0.058		15	24	0.049	12	34
LT	A,B	3.25	2	1	25			2080	128			128	1.00	1962			1962	0.065			17	50	0.026	12	16
SA, RT	B	3.50	3	1	12			2105		8	225	233	0.97	1878			1878	0.124	0.124		32	21	0.118	30	45
LT,SA	C	3.70	4	1	11			2125	51	164		215	0.24	2059			2059	0.105			27	31	0.067	24	30
SA	C	3.59	4	1				2114		221		221	0.00	2114			2114	0.105			27	31	0.067	0	0
RT	C	3.59	4	1	17			2114			243	243	1.00	1943			1943	0.125	0.125		32	31	0.081	30	32
LT,SA,RT	D	3.46	5	1	12			2101	58	16	9	83	0.81	1908			1908	0.043	0.043		11	14	0.062	12	43

NOTE : O - OPPOSING TRAFFIC N - NEAR SIDE LANE SG - STEADY GREEN FG - FLASHING GREEN PEDESTRIAN WALKING SPEED = 1.2m/s QUEUING LENGTH = AVERAGE QUEUE * 6m

OZZO TECHNOLOGY (HK) LIMITED		PRIORITY JUNCTION CALCULATION		INITIALS	DATE
Proposed Minor Relaxation of Building Height Restriction for the Permitted Educational Institution (New Science Building) in "Government, Institution or Community" Zone at Lingnan University, No. 8 Castle Peak Road - Lingnan, Tuen Mun			PROJECT NO.:	82904	PREPARED BY: LL Jan-25
J5 : Castle Peak Road - Lingnan / Fu Tei Road	2031 Ref_AM	FILENAME :	CHECKED BY: DP Jan-25		
2031 Reference Weekday AM Peak Hour Traffic Flows		J5_Castle Peak Road - Lingnan_Fu Tei Road_P.xls	REVIEWED BY: OC Jan-25		

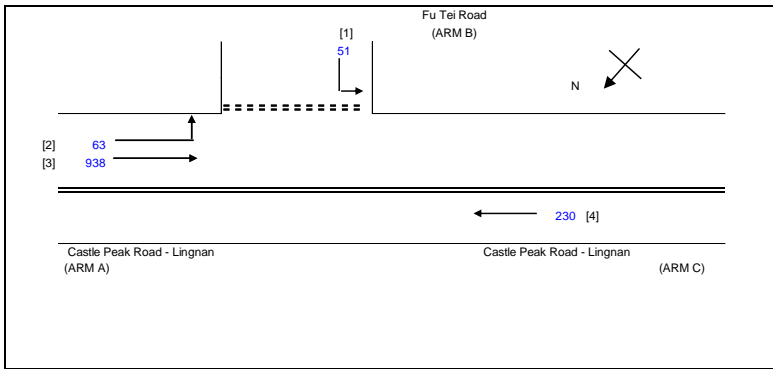

NOTES : (GEOMETRIC INPUT DATA)

- W = MAJOR ROAD WIDTH
- W cr = CENTRAL RESERVE WIDTH
- W b-a = LANE WIDTH AVAILABLE TO VEHICLE WAITING IN STREAM b-a
- W b-c = LANE WIDTH AVAILABLE TO VEHICLE WAITING IN STREAM b-c
- W c-b = LANE WIDTH AVAILABLE TO VEHICLE WAITING IN STREAM c-b
- Vl b-a = VISIBILITY TO THE LEFT FOR VEHICLES WAITING IN STREAM b-a
- Vr b-a = VISIBILITY TO THE RIGHT FOR VEHICLES WAITING IN STREAM b-a
- Vr b-c = VISIBILITY TO THE RIGHT FOR VEHICLES WAITING IN STREAM b-c
- Vr c-b = VISIBILITY TO THE RIGHT FOR VEHICLES WAITING IN STREAM c-b
- D = STREAM-SPECIFIC B-A
- E = STREAM-SPECIFIC B-C
- F = STREAM-SPECIFIC C-B
- Y = (1-0.0345W)

GEOMETRIC DETAILS:

MAJOR ROAD (ARM A)

- W = 15.94 (metres)
- W cr = 2.2 (metres)
- q a-b = 63 (pcu/hr)
- q a-c = 938 (pcu/hr)

MAJOR ROAD (ARM C)

- W c-b = 7.45 (metres)
- Vr c-b = 30 (metres)
- q c-a = 229.99 (pcu/hr)
- q c-b = (pcu/hr)

MINOR ROAD (ARM B)

- W b-a = 4.78 (metres)
- W b-c = (metres)
- Vl b-a = 88 (metres)
- Vr b-a = 78 (metres)
- Vr b-c = 78 (metres)
- q b-a = (pcu/hr)
- q b-c = 51 (pcu/hr)

GEOMETRIC FACTORS :

- D = 1.024809022
- E = 0.63206918
- F = 1.2472668
- Y = 0.4502425

THE CAPACITY OF MOVEMENT :

- Q b-a = 488
- Q b-c = 371
- Q c-b = 725

Q b-c (O) = 371

TOTAL FLOW = 1052.315505 (PCU/HR)

COMPARISON OF DESIGN FLOW TO CAPACITY:

- DFC b-a = 0.0000
- DFC b-c = 0.1373
- DFC c-b = 0.0000

CRITICAL DFC = 0.14

OZZO TECHNOLOGY (HK) LIMITED		PRIORITY JUNCTION CALCULATION		INITIALS	DATE
Proposed Minor Relaxation of Building Height Restriction for the Permitted Educational Institution (New Science Building) in "Government, Institution or Community" Zone at Lingnan University, No. 8 Castle Peak Road - Lingnan, Tuen Mun			PROJECT NO.:	82904	PREPARED BY: LL Jan-25
J5 : Castle Peak Road - Lingnan / Fu Tei Road	2031 Ref_PM	FILENAME :	CHECKED BY: DP Jan-25		
2031 Reference Weekday PM Peak Hour Traffic Flows		J5_Castle Peak Road - Lingnan_Fu Tei Road_P.xls	REVIEWED BY: OC Jan-25		

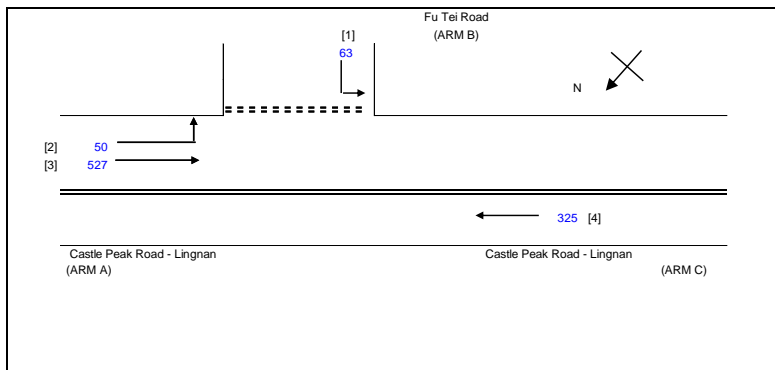

NOTES : (GEOMETRIC INPUT DATA)

- W = MAJOR ROAD WIDTH
- W cr = CENTRAL RESERVE WIDTH
- W b-a = LANE WIDTH AVAILABLE TO VEHICLE WAITING IN STREAM b-a
- W b-c = LANE WIDTH AVAILABLE TO VEHICLE WAITING IN STREAM b-c
- W c-b = LANE WIDTH AVAILABLE TO VEHICLE WAITING IN STREAM c-b
- Vl b-a = VISIBILITY TO THE LEFT FOR VEHICLES WAITING IN STREAM b-a
- Vr b-a = VISIBILITY TO THE RIGHT FOR VEHICLES WAITING IN STREAM b-a
- Vr b-c = VISIBILITY TO THE RIGHT FOR VEHICLES WAITING IN STREAM b-c
- Vr c-b = VISIBILITY TO THE RIGHT FOR VEHICLES WAITING IN STREAM c-b
- D = STREAM-SPECIFIC B-A
- E = STREAM-SPECIFIC B-C
- F = STREAM-SPECIFIC C-B
- Y = (1-0.0345W)

GEOMETRIC DETAILS:

MAJOR ROAD (ARM A)

- W = 15.94 (metres)
- W cr = 2.2 (metres)
- q a-b = 50 (pcu/hr)
- q a-c = 527 (pcu/hr)

MAJOR ROAD (ARM C)

- W c-b = 7.45 (metres)
- Vr c-b = 30 (metres)
- q c-a = 324.63 (pcu/hr)
- q c-b = (pcu/hr)

MINOR ROAD (ARM B)

- W b-a = 4.78 (metres)
- W b-c = (metres)
- Vl b-a = 88 (metres)
- Vr b-a = 78 (metres)
- Vr b-c = 78 (metres)
- q b-a = (pcu/hr)
- q b-c = 63 (pcu/hr)

GEOMETRIC FACTORS :

- D = 1.024809022
- E = 0.63206918
- F = 1.2472668
- Y = 0.4502425

THE CAPACITY OF MOVEMENT :

- Q b-a = 548
- Q b-c = 414
- Q c-b = 811
- Q b-c (O) = 414
- TOTAL FLOW = 640.7116331 (PCU/HR)

COMPARISON OF DESIGN FLOW TO CAPACITY:

- DFC b-a = 0.0000
- DFC b-c = 0.1532
- DFC c-b = 0.0000

CRITICAL DFC = 0.15

OZZO TECHNOLOGY (HK) LIMITED		PRIORITY JUNCTION CALCULATION		INITIALS	DATE
Proposed Minor Relaxation of Building Height Restriction for the Permitted Educational Institution (New Science Building) in "Government, Institution or Community" Zone at Lingnan University, No. 8 Castle Peak Road - Lingnan, Tuen Mun			PROJECT NO.:	82904	PREPARED BY: LL Jan-25
J5 : Castle Peak Road - Lingnan / Fu Tei Road	2031 Des_AM	FILENAME :	CHECKED BY: DP Jan-25		
2031 Design Weekday AM Peak Hour Traffic Flows		J5_Castle Peak Road - Lingnan_Fu Tei Road_P.xls	REVIEWED BY: OC Jan-25		

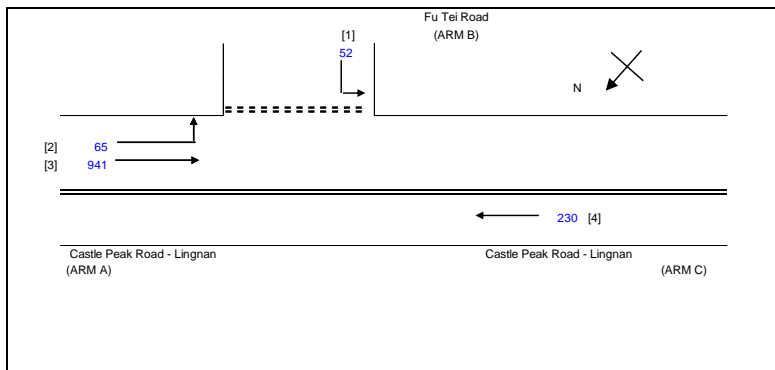

- NOTES : (GEOMETRIC INPUT DATA)
- W = MAJOR ROAD WIDTH
 - W cr = CENTRAL RESERVE WIDTH
 - W b-a = LANE WIDTH AVAILABLE TO VEHICLE WAITING IN STREAM b-a
 - W b-c = LANE WIDTH AVAILABLE TO VEHICLE WAITING IN STREAM b-c
 - W c-b = LANE WIDTH AVAILABLE TO VEHICLE WAITING IN STREAM c-b
 - VI b-a = VISIBILITY TO THE LEFT FOR VEHICLES WAITING IN STREAM b-a
 - Vr b-a = VISIBILITY TO THE RIGHT FOR VEHICLES WAITING IN STREAM b-a
 - Vr b-c = VISIBILITY TO THE RIGHT FOR VEHICLES WAITING IN STREAM b-c
 - Vr c-b = VISIBILITY TO THE RIGHT FOR VEHICLES WAITING IN STREAM c-b
 - D = STREAM-SPECIFIC B-A
 - E = STREAM-SPECIFIC B-C
 - F = STREAM-SPECIFIC C-B
 - Y = (1-0.0345W)

GEOMETRIC DETAILS:	GEOMETRIC FACTORS :	THE CAPACITY OF MOVEMENT :	COMPARISON OF DESIGN FLOW TO CAPACITY:
MAJOR ROAD (ARM A) W = 15.94 (metres) W cr = 2.2 (metres) q a-b = 65 (pcu/hr) q a-c = 941 (pcu/hr)	D = 1.024809022 E = 0.63206918 F = 1.2472668 Y = 0.4502425	Q b-a = 487 Q b-c = 371 Q c-b = 724 TOTAL FLOW = 1058.315505 (PCU/HR)	DFC b-a = 0.0000 DFC b-c = 0.1400 DFC c-b = 0.0000
MAJOR ROAD (ARM C) W c-b = 7.45 (metres) Vr c-b = 30 (metres) q c-a = 229.99 (pcu/hr) q c-b = (pcu/hr)			
MINOR ROAD (ARM B) W b-a = 4.78 (metres) W b-c = (metres) VI b-a = 88 (metres) Vr b-a = 78 (metres) Vr b-c = 78 (metres) q b-a = (pcu/hr) q b-c = 52 (pcu/hr)			
			CRITICAL DFC = 0.14

OZZO TECHNOLOGY (HK) LIMITED		PRIORITY JUNCTION CALCULATION		INITIALS	DATE
Proposed Minor Relaxation of Building Height Restriction for the Permitted Educational Institution (New Science Building) in "Government, Institution or Community" Zone at Lingnan University, No. 8 Castle Peak Road - Lingnan, Tuen Mun		PROJECT NO.:	82904	PREPARED BY:	LL Jan-25
J5 : Castle Peak Road - Lingnan / Fu Tei Road	2031 Des_PM	FILENAME :		CHECKED BY:	DP Jan-25
2031 Design Weekday PM Peak Hour Traffic Flows		J5_Castle Peak Road - Lingnan_Fu Tei Road_P.xls	REVIEWED BY:	OC Jan-25	

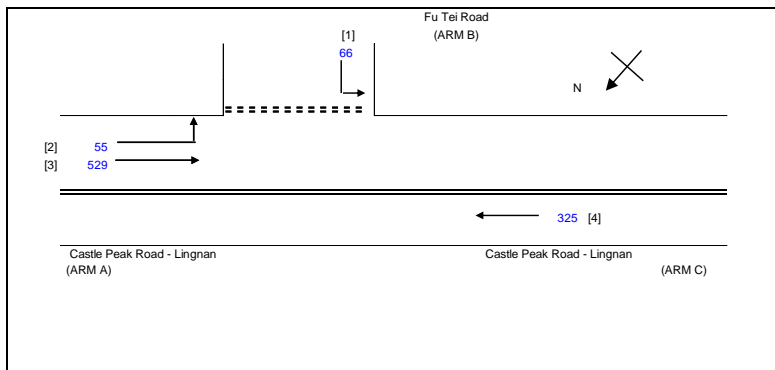

NOTES : (GEOMETRIC INPUT DATA)

- W = MAJOR ROAD WIDTH
- W cr = CENTRAL RESERVE WIDTH
- W b-a = LANE WIDTH AVAILABLE TO VEHICLE WAITING IN STREAM b-a
- W b-c = LANE WIDTH AVAILABLE TO VEHICLE WAITING IN STREAM b-c
- W c-b = LANE WIDTH AVAILABLE TO VEHICLE WAITING IN STREAM c-b
- VI b-a = VISIBILITY TO THE LEFT FOR VEHICLES WAITING IN STREAM b-a
- Vr b-a = VISIBILITY TO THE RIGHT FOR VEHICLES WAITING IN STREAM b-a
- Vr b-c = VISIBILITY TO THE RIGHT FOR VEHICLES WAITING IN STREAM b-c
- Vr c-b = VISIBILITY TO THE RIGHT FOR VEHICLES WAITING IN STREAM c-b
- D = STREAM-SPECIFIC B-A
- E = STREAM-SPECIFIC B-C
- F = STREAM-SPECIFIC C-B
- Y = (1-0.0345W)

GEOMETRIC DETAILS:	GEOMETRIC FACTORS :	THE CAPACITY OF MOVEMENT :	COMPARISON OF DESIGN FLOW TO CAPACITY:
MAJOR ROAD (ARM A) W = 15.94 (metres) W cr = 2.2 (metres) q a-b = 55 (pcu/hr) q a-c = 529 (pcu/hr)	D = 1.024809022 E = 0.63206918 F = 1.2472668 Y = 0.4502425	Q b-a = 547 Q b-c = 414 Q c-b = 810 TOTAL FLOW = 650.7116331 (PCU/HR)	DFC b-a = 0.0000 DFC b-c = 0.1604 DFC c-b = 0.0000
MAJOR ROAD (ARM C) W c-b = 7.45 (metres) Vr c-b = 30 (metres) q c-a = 324.63 (pcu/hr) q c-b = (pcu/hr)			
MINOR ROAD (ARM B) W b-a = 4.78 (metres) W b-c = (metres) VI b-a = 88 (metres) Vr b-a = 78 (metres) Vr b-c = 78 (metres) q b-a = (pcu/hr) q b-c = 66 (pcu/hr)			
			CRITICAL DFC = 0.16

OZZO TECHNOLOGY (HK) LIMITED		PRIORITY JUNCTION CALCULATION		INITIALS	DATE
Proposed Minor Relaxation of Building Height Restriction for the Permitted Educational Institution (New Science Building) in "Government, Institution or Community" Zone at Lingnan University, No. 8 Castle Peak Road - Lingnan, Tuen Mun			PROJECT NO.: 82904	PREPARED BY: LL	Jan-25
J6: Fu Tei Road / Southern Access of Lingnan University		2031 Ref_AM	FILENAME :	CHECKED BY: DP	Jan-25
2031 Reference Weekday AM Peak Hour Traffic Flows			u Tei Road_Southern Access of Lingnan University_P.xls	REVIEWED BY: OC	Jan-25

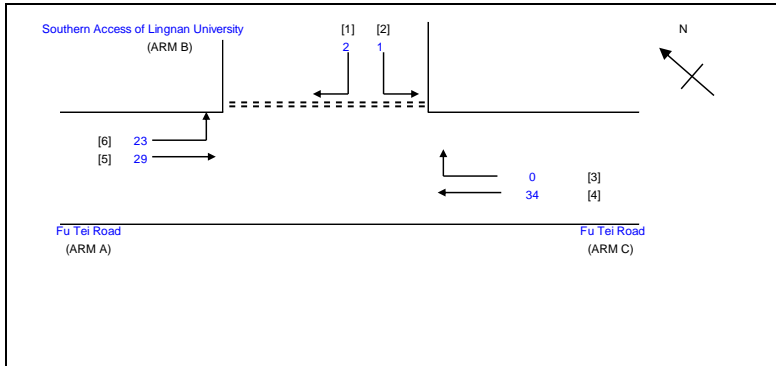

NOTES : (GEOMETRIC INPUT DATA)

- W = MAJOR ROAD WIDTH
- W cr = CENTRAL RESERVE WIDTH
- W b-a = LANE WIDTH AVAILABLE TO VEHICLE WAITING IN STREAM b-a
- W b-c = LANE WIDTH AVAILABLE TO VEHICLE WAITING IN STREAM b-c
- W c-b = LANE WIDTH AVAILABLE TO VEHICLE WAITING IN STREAM c-b
- Vi b-a = VISIBILITY TO THE LEFT FOR VEHICLES WAITING IN STREAM b-a
- Vr b-a = VISIBILITY TO THE RIGHT FOR VEHICLES WAITING IN STREAM b-a
- Vr b-c = VISIBILITY TO THE RIGHT FOR VEHICLES WAITING IN STREAM b-c
- Vr c-b = VISIBILITY TO THE RIGHT FOR VEHICLES WAITING IN STREAM c-b
- D = STREAM-SPECIFIC B-A
- E = STREAM-SPECIFIC B-C
- F = STREAM-SPECIFIC C-B
- Y = (1-0.0345W)

GEOMETRIC DETAILS:	GEOMETRIC FACTORS :	THE CAPACITY OF MOVEMENT :	COMPARISON OF DESIGN FLOW TO CAPACITY:
MAJOR ROAD (ARM A) W = 7.61 (metres) W cr = 0 (metres) q a-b = 22.645 (pcu/hr) q a-c = 29.438 (pcu/hr)	D = 0.895777361 E = 0.949922297 F = 0.9319579 Y = 0.737455	Q b-a = 547 Q b-c = 698 Q c-b = 681 Q b-ac = 547	DFC b-a = 0.0041 DFC b-c = 0.0016 DFC c-b = 0.0000 DFC b-c (share lane) = 0.0062
MAJOR ROAD (ARM C) W c-b = 3.8 (metres) Vr c-b = 30 (metres) q c-a = 33.967 (pcu/hr) q c-b = 0 (pcu/hr)	F for (Qb-ac) = 0	TOTAL FLOW = 89.44640533 (PCU/HR)	
MINOR ROAD (ARM B) W b-a = 3.3 (metres) W b-c = 3.3 (metres) Vi b-a = 55 (metres) Vr b-a = 100 (metres) Vr b-c = 100 (metres) q b-a = 2.2645 (pcu/hr) q b-c = 1.1322 (pcu/hr)			CRITICAL DFC = 0.01

OZZO TECHNOLOGY (HK) LIMITED

PRIORITY JUNCTION CALCULATION

INITIALS

DATE

Proposed Minor Relaxation of Building Height Restriction for the Permitted Educational Institution (New Science Building) in "Government, Institution or Community" Zone at Lingnan University, No. 8 Castle Peak Road - Lingnan, Tuen Mun

PROJECT NO.: 82904

PREPARED BY: LL

Jan-25

J6: Fu Tei Road / Southern Access of Lingnan University

2031 Ref_PM

FILENAME :

CHECKED BY: DP

Jan-25

2031 Reference Weekday PM Peak Hour Traffic Flows

J6 Fu Tei Road_Southern Access of Lingnan University_P.xls

REVIEWED BY: OC

Jan-25

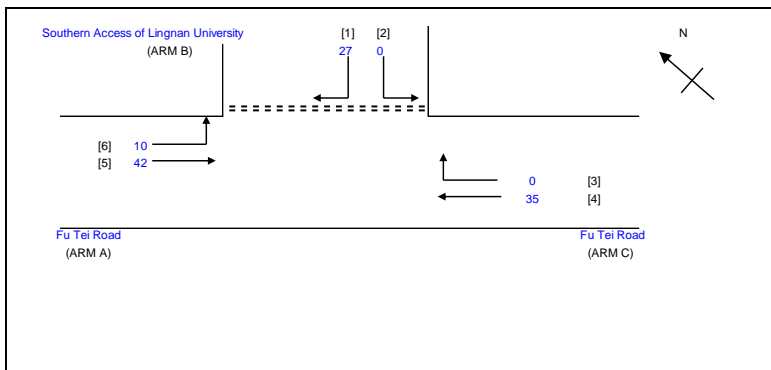

NOTES : (GEOMETRIC INPUT DATA)

- W = MAJOR ROAD WIDTH
- W cr = CENTRAL RESERVE WIDTH
- W b-a = LANE WIDTH AVAILABLE TO VEHICLE WAITING IN STREAM b-a
- W b-c = LANE WIDTH AVAILABLE TO VEHICLE WAITING IN STREAM b-c
- W c-b = LANE WIDTH AVAILABLE TO VEHICLE WAITING IN STREAM c-b
- VI b-a = VISIBILITY TO THE LEFT FOR VEHICLES WAITING IN STREAM b-a
- Vr b-a = VISIBILITY TO THE RIGHT FOR VEHICLES WAITING IN STREAM b-a
- Vr b-c = VISIBILITY TO THE RIGHT FOR VEHICLES WAITING IN STREAM b-c
- Vr c-b = VISIBILITY TO THE RIGHT FOR VEHICLES WAITING IN STREAM c-b
- D = STREAM-SPECIFIC B-A
- E = STREAM-SPECIFIC B-C
- F = STREAM-SPECIFIC C-B
- Y = (1-0.0345W)

GEOMETRIC DETAILS:

MAJOR ROAD (ARM A)
 W = 7.61 (metres)
 W cr = 0 (metres)
 q a-b = 10.19 (pcu/hr)
 q a-c = 41.893 (pcu/hr)

GEOMETRIC FACTORS :

D = 0.895777361
 E = 0.94992297
 F = 0.9319579
 Y = 0.737455

THE CAPACITY OF MOVEMENT :

Q b-a = 545
 Q b-c = 696
 Q c-b = 681
 Q b-ac = 545

COMPARISON OF DESIGN FLOW TO CAPACITY:

DFC b-a = 0.0499
 DFC b-c = 0.0000
 DFC c-b = 0.0000
 DFC b-c (share lane) = 0.0499

MAJOR ROAD (ARM C)
 W c-b = 3.8 (metres)
 Vr c-b = 30 (metres)
 q c-a = 35.099 (pcu/hr)
 q c-b = 0 (pcu/hr)

F for (Qb-ac) = 0

TOTAL FLOW = 114.3555309 (PCU/HR)

CRITICAL DFC = 0.05

MINOR ROAD (ARM B)
 W b-a = 3.3 (metres)
 W b-c = 3.3 (metres)
 VI b-a = 55 (metres)
 Vr b-a = 100 (metres)
 Vr b-c = 100 (metres)
 q b-a = 27.174 (pcu/hr)
 q b-c = 0 (pcu/hr)

OZZO TECHNOLOGY (HK) LIMITED

PRIORITY JUNCTION CALCULATION

INITIALS

DATE

Proposed Minor Relaxation of Building Height Restriction for the Permitted Educational Institution (New Science Building) in "Government, Institution or Community" Zone at Lingnan University, No. 8 Castle Peak Road - Lingnan, Tuen Mun

PROJECT NO.: 82904

PREPARED BY: LL

Jan-25

J6: Fu Tei Road / Southern Access of Lingnan University

2031 Des_AM

FILENAME :

CHECKED BY: DP

Jan-25

2031 Design Weekday AM Peak Hour Traffic Flows

Ju Tei Road_Southern Access of Lingnan University_P.xls

REVIEWED BY: OC

Jan-25

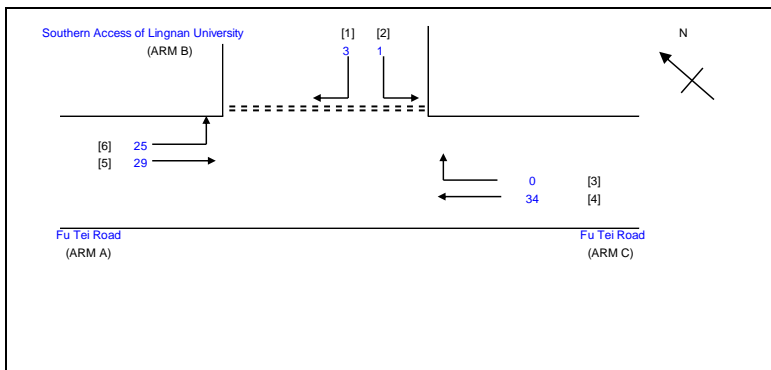

NOTES : (GEOMETRIC INPUT DATA)

- W = MAJOR ROAD WIDTH
- W cr = CENTRAL RESERVE WIDTH
- W b-a = LANE WIDTH AVAILABLE TO VEHICLE WAITING IN STREAM b-a
- W b-c = LANE WIDTH AVAILABLE TO VEHICLE WAITING IN STREAM b-c
- W c-b = LANE WIDTH AVAILABLE TO VEHICLE WAITING IN STREAM c-b
- VI b-a = VISIBILITY TO THE LEFT FOR VEHICLES WAITING IN STREAM b-a
- Vr b-a = VISIBILITY TO THE RIGHT FOR VEHICLES WAITING IN STREAM b-a
- Vr b-c = VISIBILITY TO THE RIGHT FOR VEHICLES WAITING IN STREAM b-c
- Vr c-b = VISIBILITY TO THE RIGHT FOR VEHICLES WAITING IN STREAM c-b
- D = STREAM-SPECIFIC B-A
- E = STREAM-SPECIFIC B-C
- F = STREAM-SPECIFIC C-B
- Y = (1-0.0345W)

GEOMETRIC DETAILS:

MAJOR ROAD (ARM A)
 W = 7.61 (metres)
 W cr = 0 (metres)
 q a-b = 24.645 (pcu/hr)
 q a-c = 29.438 (pcu/hr)

GEOMETRIC FACTORS :

D = 0.895777361
 E = 0.94992297
 F = 0.9319579
 Y = 0.737455

THE CAPACITY OF MOVEMENT :

Q b-a = 547
 Q b-c = 698
 Q c-b = 681
 Q b-ac = 547

COMPARISON OF DESIGN FLOW TO CAPACITY:

DFC b-a = 0.0060
 DFC b-c = 0.0016
 DFC c-b = 0.0000
 DFC b-c (share lane) = 0.0080

MAJOR ROAD (ARM C)
 W c-b = 3.8 (metres)
 Vr c-b = 30 (metres)
 q c-a = 33.967 (pcu/hr)
 q c-b = 0 (pcu/hr)

F for (Qb-ac) = 0

TOTAL FLOW = 92.44640533 (PCU/HR)

CRITICAL DFC = 0.01

MINOR ROAD (ARM B)
 W b-a = 3.3 (metres)
 W b-c = 3.3 (metres)
 VI b-a = 55 (metres)
 Vr b-a = 100 (metres)
 Vr b-c = 100 (metres)
 q b-a = 3.2645 (pcu/hr)
 q b-c = 1.1322 (pcu/hr)

OZZO TECHNOLOGY (HK) LIMITED

PRIORITY JUNCTION CALCULATION

INITIALS

DATE

Proposed Minor Relaxation of Building Height Restriction for the Permitted Educational Institution (New Science Building) in "Government, Institution or Community" Zone at Lingnan University, No. 8 Castle Peak Road - Lingnan, Tuen Mun

PROJECT NO.: 82904

PREPARED BY: LL

Jan-25

J6: Fu Tei Road / Southern Access of Lingnan University

2031 Des_PM

FILENAME :

CHECKED BY: DP

Jan-25

2031 Design Weekday PM Peak Hour Traffic Flows

J6 Fu Tei Road_Southern Access of Lingnan University_P.xls

REVIEWED BY: OC

Jan-25

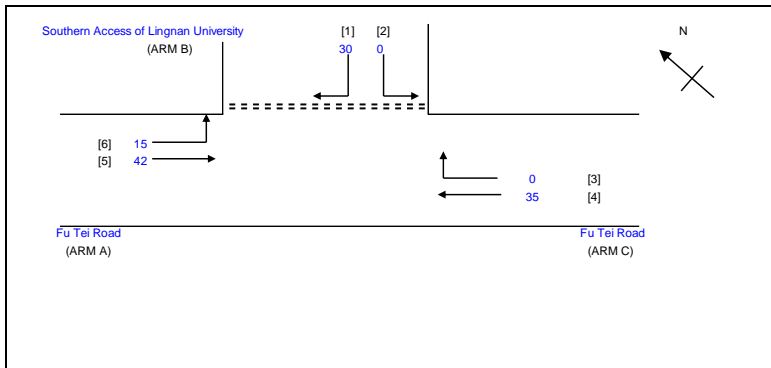

NOTES : (GEOMETRIC INPUT DATA)

- W = MAJOR ROAD WIDTH
- W cr = CENTRAL RESERVE WIDTH
- W b-a = LANE WIDTH AVAILABLE TO VEHICLE WAITING IN STREAM b-a
- W b-c = LANE WIDTH AVAILABLE TO VEHICLE WAITING IN STREAM b-c
- W c-b = LANE WIDTH AVAILABLE TO VEHICLE WAITING IN STREAM c-b
- VI b-a = VISIBILITY TO THE LEFT FOR VEHICLES WAITING IN STREAM b-a
- Vr b-a = VISIBILITY TO THE RIGHT FOR VEHICLES WAITING IN STREAM b-a
- Vr b-c = VISIBILITY TO THE RIGHT FOR VEHICLES WAITING IN STREAM b-c
- Vr c-b = VISIBILITY TO THE RIGHT FOR VEHICLES WAITING IN STREAM c-b
- D = STREAM-SPECIFIC B-A
- E = STREAM-SPECIFIC B-C
- F = STREAM-SPECIFIC C-B
- Y = (1-0.0345W)

GEOMETRIC DETAILS:

MAJOR ROAD (ARM A)
 W = 7.61 (metres)
 W cr = 0 (metres)
 q a-b = 15.19 (pcu/hr)
 q a-c = 41.893 (pcu/hr)

GEOMETRIC FACTORS :

D = 0.895777361
 E = 0.94992297
 F = 0.9319579
 Y = 0.737455

THE CAPACITY OF MOVEMENT :

Q b-a = 545
 Q b-c = 695
 Q c-b = 680
 Q b-ac = 545

COMPARISON OF DESIGN FLOW TO CAPACITY:

DFC b-a = 0.0554
 DFC b-c = 0.0000
 DFC c-b = 0.0000
 DFC b-c (share lane) = 0.0554

MAJOR ROAD (ARM C)
 W c-b = 3.8 (metres)
 Vr c-b = 30 (metres)
 q c-a = 35.099 (pcu/hr)
 q c-b = 0 (pcu/hr)

F for (Qb-ac) = 0

TOTAL FLOW = 122.3555309 (PCU/HR)

CRITICAL DFC = 0.06

MINOR ROAD (ARM B)
 W b-a = 3.3 (metres)
 W b-c = 3.3 (metres)
 VI b-a = 55 (metres)
 Vr b-a = 100 (metres)
 Vr b-c = 100 (metres)
 q b-a = 30.174 (pcu/hr)
 q b-c = 0 (pcu/hr)

Annex E

Queue Length Assessment

X:\02082904_Consultancy Services for the New Research and Academic Building of Lingnan University\Data\Dwg\82904_Queue length_J2_2037 Des.dwg 2024/11/05 13:52:55

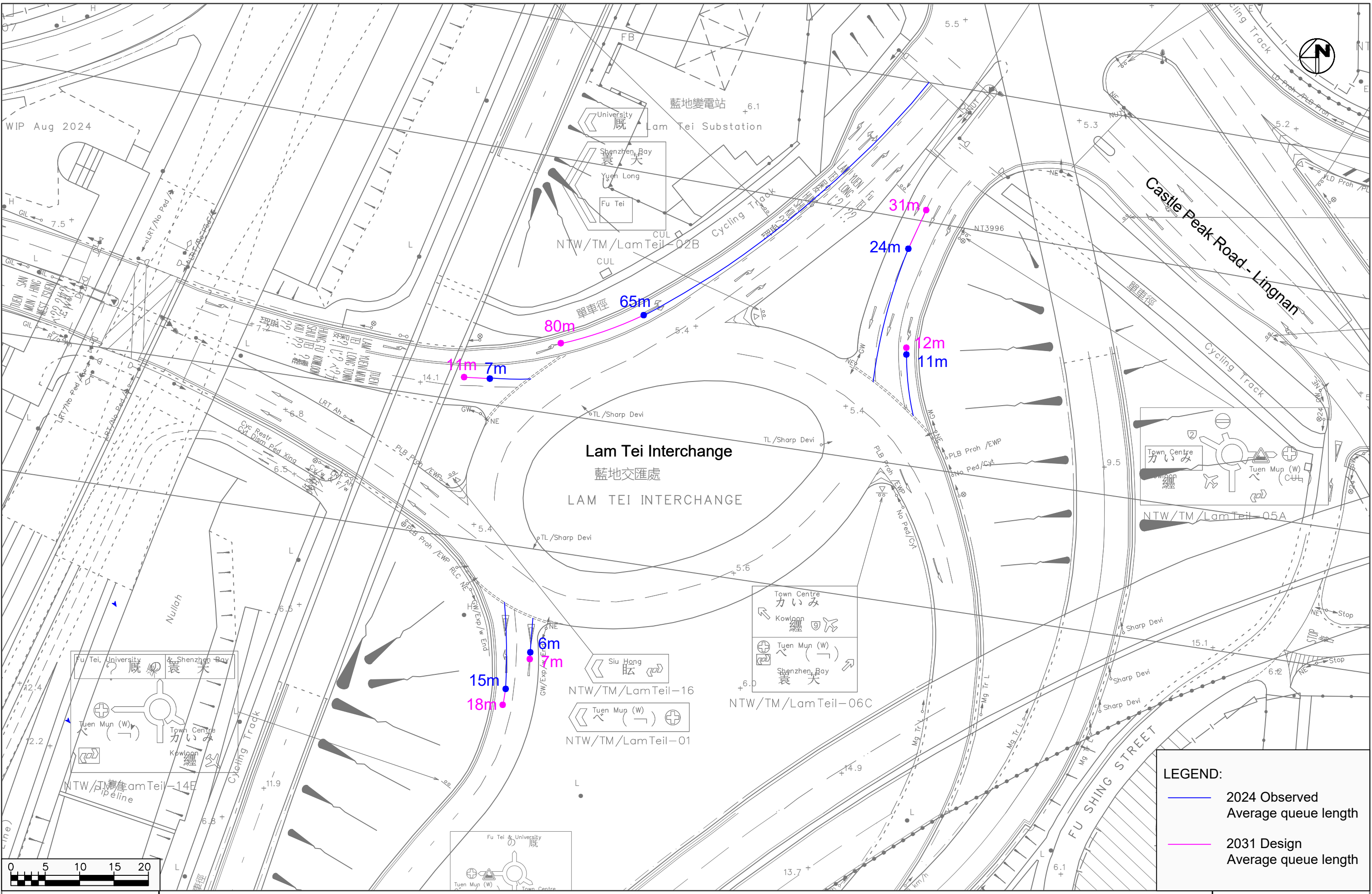

Proposed Minor Relaxation of Building Height Restriction for the Permitted Educational Institution (New Science Building) in “Government, Institution or Community” Zone at Lingnan University, No. 8 Castle Peak Road – Lingnan, Tuen Mun

Queue Length of Lam Tei Interchange (J2) - AM Peak

LEGEND:

- 2024 Observed Average queue length
- 2031 Design Average queue length

Date	Scale
05/11/2024	1:500

OZZO TECHNOLOGY

Dwg No.	Rev.
82904-Queue-1	-

X:\02z0182904_Consultancy Services for the New Research and Academic Building of Lingnan University\Data\DWG\82904_Queue length_J2_2037 Des.dwg 2024/11/05 13:53:43

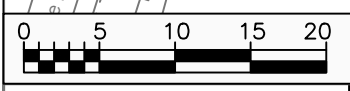
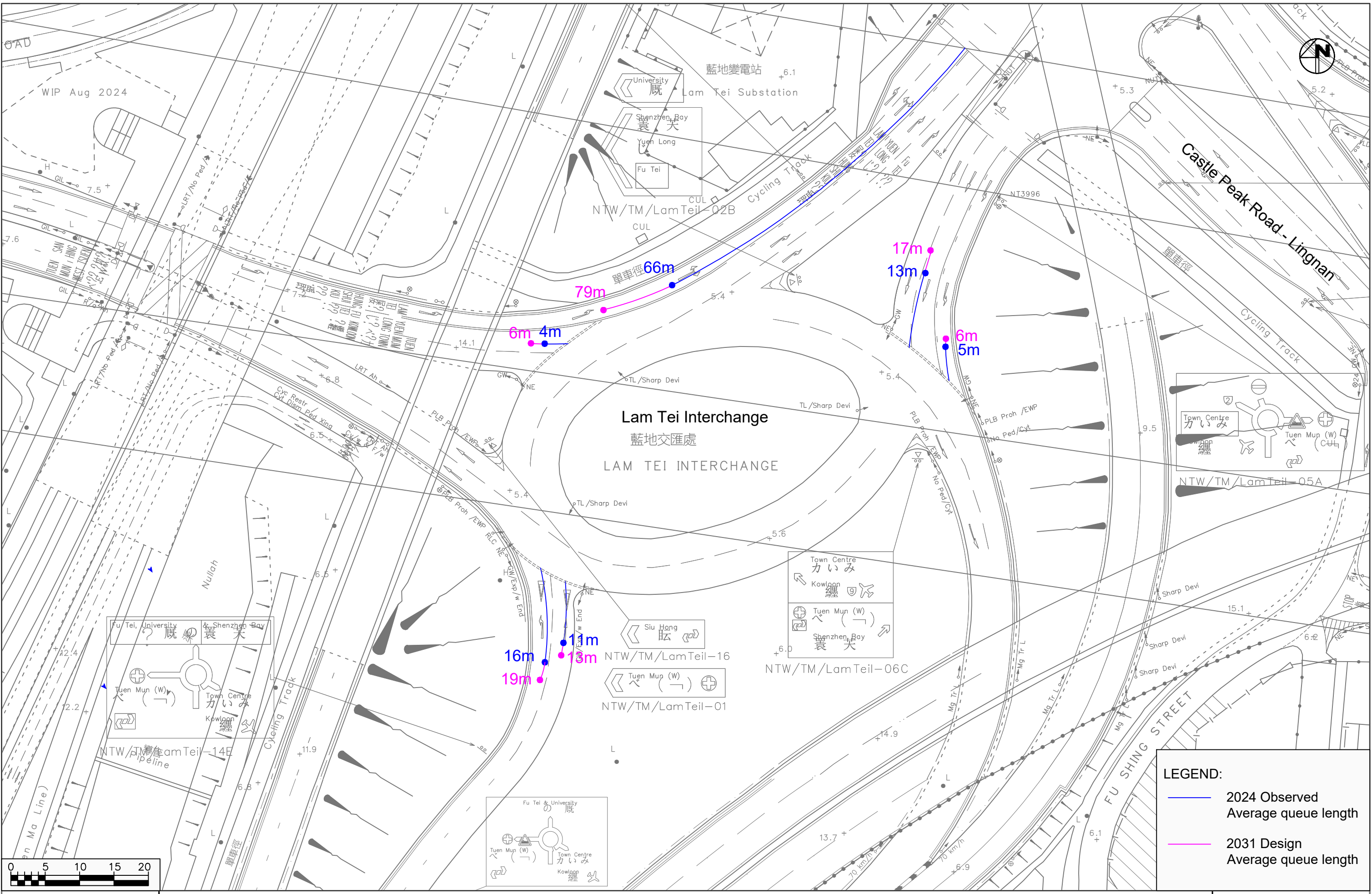

Proposed Minor Relaxation of Building Height Restriction for the Permitted Educational Institution (New Science Building) in “Government, Institution or Community” Zone at Lingnan University, No. 8 Castle Peak Road – Lingnan, Tuen Mun

Queue Length of Lam Tei Interchange (J2) - PM Peak

Date: 05/11/2024
Scale: 1:500

LEGEND:

- 2024 Observed Average queue length
- 2031 Design Average queue length



Dwg No. 82904-Queue-2
Rev. -