

Urgent Return receipt Expand Group Restricted Prevent Copy

Tracy Wing Sum LAW/PLAND

寄件者: Jacky TK LAU [REDACTED]
寄件日期: 2025年01月09日星期四 16:45
收件者: tpbpd/PLAND
副本: Ada Siu Man CHAN/PLAND; [REDACTED]; Tracy Wing Sum LAW/PLAND;
Wilfred Ka Hing CHU/PLAND; [REDACTED]
主旨: Re: Planning Application No. A/YL-LFS/545 - Departmental Comments
附件: LFS PAWR S16 Planning Statement_v2.3.pdf

Dear Sir/Madam,

This email supersedes the preceding email sent to you at 14:47 today.

In response to the comments from the Planning Department, attached is our submission of an updated Planning Statement. In particular, **Para. 3.2.2, Para. 6.2.2, Photo 3 and Drawing 3** are updated.

Thank you very much.

Regards,
Jacky TK LAU
Scientific Officer (Radar and Satellite Meteorology) 41
Hong Kong Observatory
[REDACTED]

From: Jacky TK LAU [REDACTED]
To: tpbpd@pland.gov.hk
Cc: "Ada Siu Man CHAN/PLAND" <asmchan@pland.gov.hk>, "Tracy Wing Sum LAW/PLAND" <twslaw@pland.gov.hk>, "Wilfred Ka Hing CHU/PLAND" <wkhchu@pland.gov.hk>, [REDACTED]
Date: 09/01/2025 02:47 PM
Subject: Re: Planning Application No. A/YL-LFS/545 - Departmental Comments

Dear Sir/Madam,

In response to the comments from the Planning Department, attached is our submission of an updated Planning Statement. In particular, **Para. 6.2.2, Photo 3 and Drawing 3** are updated.

Thank you very much.

Regards,
Jacky TK LAU
Scientific Officer (Radar and Satellite Meteorology) 41
Hong Kong Observatory

Urgent Return receipt Expand Group Restricted Prevent Copy

From: "Wilfred Ka Hin CHU/PLAND" <wkhchu@pland.gov.hk>
To: "Jacky TK LAU" <[REDACTED]>
Cc: "Ada Siu Man CHAN/PLAND" <asmchan@pland.gov.hk>, "Tracy Wing Sum LAW/PLAND" <twslaw@pland.gov.hk>
Date: 09/01/2025 09:28 AM
Subject: Planning Application No. A/YL-LFS/545 - Departmental Comments

Dear Jacky,

Regarding your submission of planning application no. A/YL-LFS/545, please find below comments from concerned Government Departments for your further action please.

[Comments of the Chief Town Planner/Urban Design and Landscape, Planning Department \(Contact Officer: Ms. Charlotte KO; Tel: 3565 3946\)](#)

2. **Para. 6.2.2** – According to Drawings 2 and 3, the height of flushing/cleansing tank and pumps room is about 42mPD. Please review/clarify whether the height of the proposed radar installation on top of the flushing/cleansing tank and pumps room is about 45mPD, instead of 42mPD.
3. **Drawing 3** – For the sake of clarity, the applicant may wish to annotate the proposed radar installation with its dimensions.

Should you wish to submit further information in response to the above, please do so by **14.1.2025** and submit in writing to Secretary of the Town Planning Board (email: tpbpd@pland.gov.hk; Address: 15/F, North Point Government Offices, 333 Java Road, North Point, Hong Kong; Fax: 2877 0245) with copy to us. In submitting the further information, reference should be made to the TPB Guidelines No. 32B on the Submission of Further Information in Relation to Applications for Amendment of Plan, Planning Permission and Review.

Thanks and Regards,
Wilfred CHU
TP/YLW4, TMYLW DPO, PlanD
Tel: 2158 6290

Hong Kong
Observatory

**S16 Application for
Phased Array Weather
Radar**

Planning Statement

December 2024

Version 2.3

Contents

| | Page |
|---|------|
| Executive Summary | 1 |
| 1 Introduction | 2 |
| 2 Background of Proposed Development | 3 |
| 3 Site Context..... | 4 |
| 3.1 Location | 4 |
| 3.2 Existing Conditions | 4 |
| 3.3 Surrounding Land Uses | 4 |
| 3.4 Accessibility | 4 |
| 4 Land Status | 5 |
| 5 Planning Context | 5 |
| 5.1 Statutory Plan | 5 |
| 5.2 Previous/ Similar Application | 5 |
| 6 Development Proposal | 6 |
| 6.1 Proposed Development | 6 |
| 6.2 Site Layout and Design | 6 |
| 6.3 Landscape Plan | 6 |
| 7 Technical Assessments..... | 6 |
| 7.1 Engineering Issues | 6 |
| 7.2 Environmental Assessment | 6 |
| 7.3 Landscape and Visual | 7 |
| 7.4 Microwave Radiation | 7 |
| 8 Justifications..... | 8 |
| 8.1 Monitor of High-Impact Weather at Low-Altitude | 8 |
| 8.2 Compatible Development Scale | 8 |
| 8.3 Negligible Environmental Impact | 8 |
| 8.4 No Adverse Visual Impact | 8 |
| 9 Conclusion | 9 |
| Appendix 1: Plan | 10 |
| Appendix 2: Photo..... | 12 |
| Appendix 3: Drawing..... | 15 |
| Appendix 4: Photomontage..... | 20 |

Executive Summary

The Hong Kong Observatory of the HKSARG is applying for planning approval from the Town Planning Board under section 16 of the Town Planning Ordinance to install a new phased array weather radar system (PAWRS). The Subject Site is located on the rooftop of Former Lau Fau Shan Police Station, Yuen Long. According to the Approved Lau Fau Shan and Tsim Bei Tsui Outline Zoning Plan (OZP) No. S/YL-LFS/11 dated 22.4.2022, the Subject Site falls within an area zoned “Government, Institution or Community”. According to the Notes of the OZP, “Radar, Telecommunication Electronic Microwave Repeater, Television and/or Radio Transmitter Installation” are Column 2 uses that may be permitted with or without conditions on application to the Board.

The Hong Kong Observatory (HKO) proposes to implement a PAWRS network for enhancing HKO’s capability of territory-wide monitoring and predicting high impact weather in Hong Kong. The application site is identified as a strategic site with good coverage of the northern part of the New Territories including the Northern Metropolis for monitoring the high-impact weather including rainstorms, hails and severe thunderstorms, etc.

The Subject Site is located within Government Land in which Hong Kong Guide Dogs Academy Limited is the tenant. The site area is approximately 14.1m². The proposed installation will consist of a PAWRS which will operate automatically round-the-clock on a 24/7 basis with little maintenance effort.

The applicant has operational genuine need for installing the PAWRS. The proposed development scale and form is compatible with the structure of the building. Technical assessments have demonstrated that the proposed development is feasible and sustainable from engineering and environmental points of view, and would not pose adverse impact to the existing environment, ecology, landscape and visual conditions of the Subject Site. For the reasons above, approval of the proposed development would not set an undesirable precedent for the “Government, Institution or Community” zoning.

1 Introduction

This is a planning application by the Hong Kong Observatory (HKO) of the HKSARG under section 16 of the Town Planning Ordinance (Cap.131). The Applicant intends to install a phased array weather radar system (PAWRS) on top of a flushing/cleansing tank & pumps room (“the Subject Site”) on the rooftop of Former Lau Fau Shan Police Station, Yuen Long, New Territories.

Under the Approved Lau Fau Shan and Tsim Bei Tsui Outline Zoning Plan (OZP) No. S/YL-LFS/11 dated 22.4.2022, the Subject Site falls within an area zoned “Government, Institution or Community” (“GI/C”). An extract of the OZP is shown in **Plan 1**. According to the Notes of the OZP, “Radar, Telecommunication Electronic Microwave Repeater, Television and/or Radio Transmitter Installation” are uses in Column 2 that may be permitted with or without conditions on application to the Town Planning Board (the “Board”).

This Planning Statement is intended to facilitate consideration of the application by members of the Board and relevant Government departments / offices. The following sections will provide a description on the background of the proposal, the Subject Site and its surroundings, details of the proposed development and justifications in support of the application.

2 Background of Proposed Development

Global warming has led to more frequent and intense extreme weather events around the world. Like other major cities, Hong Kong is facing more and more extreme weather phenomena with both the annual rainfall and number of heavy rain days showing an upward trend. As a coastal city, Hong Kong is susceptible to weather-related threats such as tropical cyclones, rainstorms and storm surges. To address the growing challenges of climate change and more frequent extreme weather in Hong Kong, HKO has operated a PAWRS in Sha Lo Wan (SLW) since 2021 to provide high spatiotemporal resolution of radar imagery. After two years of trial operation, the SLW PAWRS has demonstrated its effectiveness in detecting rapidly changing high-impact weather. PAWRS can effectively capture rapidly changing inclement weather such as tornadoes, hail, intense thunderstorms and the associated severe gusts. Furthermore, the PAWRS can provide automated detection and advanced alerts of inclement weather systems to enhance HKO's forecasting and warning services.

As the maximum range covered by the SLW PAWRS is limited to around 60 kilometres, which cannot cover the entire territory, it is necessary to implement a PAWRS network covering the entire Hong Kong including densely populated areas.

Moreover, according to the Policy Address 2024, low-altitude economy, which refers to economic activities in airspace below 1000 metres, presents a wide array of application scenarios including rescues, surveys and delivery of goods and passengers. PAWRSs could monitor low-altitude weather and provide valuable meteorological information to low-altitude aircrafts such as drones, facilitating the development of low-altitude economy.

The locational requirements of the new PAWRS are determined by a set of stringent technical criteria. Such requirements are detailed as follows:

- a. A clear field of view so that the radar beam would not be blocked by near terrain and buildings;
- b. The site together with other potential radar sites should be scattered evenly over Hong Kong;
- c. The height of the PAWRS should preferably be lower than 100 metres above mean sea level (a.m.s.l.) for the monitoring of low-altitude weather; and
- d. The PAWRS should be higher than surrounding buildings or facilities to avoid potential blockage of radar beam.

The Subject Site has been assessed by HKO as a strategic site very suitable for installation of new PAWRS based on the following reasons:

- a. The Subject Site has unobstructed views of the northern part of the New Territories covering the Northern Metropolis, making it an ideal frontline station for monitoring severe weather such as squall lines approaching Hong Kong from the west to northwest (**Drawing 1**);

- b. The Subject Site is located at the northwestern part of Hong Kong with very suitable network connection distance to the PAWRS at Qiu Yu Tan (around 25 km to the northwest of Lau Fau Shan) in western Shenzhen operated by the Meteorological Bureau of Shenzhen Municipality;
- c. The Subject Site has a height of around 40m a.m.s.l.; and
- d. The Subject Site is situated on hilltop and is higher than surrounding buildings or facilities.

At present, there is existing vehicular access to the site.

3 Site Context

3.1 Location

- 3.1.1 The Subject Site is situated at the rooftop of the Former Lau Fau Shan Police Station in Yuen Long, which is at the top of a small hill (**Plan 1**).

3.2 Existing Conditions

- 3.2.1 The Subject Site is located within the Former Lau Fau Shan Police Station, which will be converted into a guide dogs academy for guide dogs breeding and training under Batch V of Revitalisation Scheme (**Photos 1 & 2** and **Drawings 2 & 4**).
- 3.2.2 The PAWRS to be installed at the Subject Site is about 1.2m (Length) x 1.1m (Width) x 2.9m (Height), taking reference to the existing SLW PAWRS (**Photo 3**). It will be installed on top of a steel supporting frame which is about 3.0m (Length) x 3.0m (Width) x 0.9m (Height). The actual size and model would be subject to the result of the future open tender exercise.

3.3 Surrounding Land Uses

- 3.3.1 The Subject Site is located within the Former Lau Fau Shan Police Station, which is on top of a small hill whilst surrounding developments are located at the foot of the hill (**Photo 1**).
- 3.3.2 The land lying in the vicinity around the hill is a “Coastal Protection Area” (“CPA”) zone. No developments are within this area.
- 3.3.3 The land areas lying to the south and southwest of CPA zone are “Commercial/Residential” (“C/R”) zone and to the southeast “Residential (Group E)” (“R(E)”) zone, respectively. There are residential dwellings/settlements and seafood market within the C/R zone.
- 3.3.4 To the northeast of the hill, there is a “Recreation” (“REC”) zone intended for recreational developments for the use of the general public.
- 3.3.5 Shenzhen Bay lies to the west of the hill, with Shenzhen Bay bridge built across the bay.

3.4 Accessibility

- 3.4.1 There is vehicular access to the Subject Site along Shan Tung Street branched off from the roundabout at Lau Fau Shan Seafood Village.

4 Land Status

The Subject Site covers an area of about 14.1m². The entire site is within Government Land.

5 Planning Context

5.1 Statutory Plan

- 5.1.1** According to the OZP, the Subject Site falls within an area zoned “G/IC”. “Radar, Telecommunication Electronic Microwave Repeater, Television and/or Radio Transmitter Installation” are Column 2 uses that may be permitted with or without conditions on application to the Board.
- 5.1.2** The planning intention of the “G/IC” zone is primarily for the provision of Government, institution or community facilities serving the needs of the local residents and/or a wider district, region or the territory. It is also intended to provide land for uses directly related to or in support of the work of the Government, organizations providing social services to meet community needs, and other institutional establishments.
- 5.1.3** Part of Lau Fau Shan Site of Archaeological Interest and Former Lau Fau Shan Police Station, a grade 3 historic building, falls within this zone. HKO has consulted with AMO for the installation of PAWRS. AMO has no objection and HKO will follow AMO’s requirements in installing the PAWRS.
- 5.1.4** HKO has been operating an automatic weather station (AWS) at the Former Lau Fau Shan Police since 1985. The AWS is currently providing essential meteorological observation data including wind direction, wind speed, air temperature, relative humidity, rainfall and air pressure and is also one of the eight reference anemometer stations in the tropical cyclone warning system. The addition of a PAWRS at the site reflects the operational need of HKO to install new advanced small-size PAWRS to cope with the increasing extreme weather affecting Hong Kong.

5.2 Previous/ Similar Application

- 5.2.1** There is no previous application pertaining to the Subject Site.

6 Development Proposal

6.1 Proposed Development

- 6.1.1 The proposed development is a remotely controlled, automatic PAWRS. The system will operate automatically round-the-clock on 24/7 basis with little maintenance effort.
- 6.1.2 The PAWRS is planned to be installed and commissioned in 2027.

6.2 Site Layout and Design

- 6.2.1 The PAWRS is located on top of a flushing/cleansing tank & pumps room on the rooftop of the Former Lau Fau Shan Police Station.
- 6.2.2 The system will be the second highest facility within the Former Lau Fau Shan Police Station (the highest being the anemometer (about 52 mPD)) and its height will be about 46 mPD (**Drawing 3**).
- 6.2.3 The colour of the PAWRS will be white in colour, matching one of the main color of the building as shown in **Photomontage 1** in Appendix 4.

6.3 Landscape Plan

- 6.3.1 There is no need for landscaping.

7 Technical Assessments

7.1 Engineering Issues

7.1.1 Lightning Protection

To ensure the proposed PAWRS is protected against lightning strikes, lightning protection system will be designed in accordance with relevant Government regulatory codes and standards. In addition, extra down conductors and surge arrestors will be installed and earth resistance will be further enhanced.

7.1.2 Traffic

The PAWRS will cause no effect on the existing traffic flow in the local roads as the system operates automatically and requires little maintenance effort.

7.2 Environmental Assessment

- 7.2.1 The proposed PAWRS will cause negligible environmental impact to the area. The system runs on electrical power and there is minimal noise caused by its operation.

7.3 Landscape and Visual

7.3.1 The potential impact of the proposed PAWRS is acceptable from landscape and visual points of view as there will be no significant landscape and visual impact caused by its appearance or interference with key views.

7.4 Microwave Radiation

7.4.1 The PAWRS will be located on the rooftop of Former Lau Fau Shan Police Station on top of a small hill (see **Plan 1**). The public will be protected from exposure to the low-energy microwave radiation emitted from the PAWRS in the following ways:

- (a) HKO will put in place effective safety measures in accordance with international standards to ensure the PAWRS's full compliance with the radiation safety requirements;
- (b) the radar antenna which sends out the microwave radiation into the atmosphere will be programmed to only pointing upwards above the horizon;
- (c) the radar antenna is designed in a way that it cannot dip below the horizon in any event;
- (d) 'blank sectors' will be implemented if necessary so that no microwave radiation will be transmitted by the radar in the directions within the blank sectors.
- (e) HKO staff will carry out regular Non-ionising radiation (NIR) surveys to ensure safety operation of the PAWRS.

With the above protection measures, both the residents in the nearby buildings, which are located downhill of the PAWRS, and visitors coming to Lau Fau Shan will be protected from exposure to the low-energy microwave radiation emitted by the PAWRS.

8 Justifications

8.1 Monitor of High-Impact Weather at Low-Altitude

- 8.1.1** The proposed PAWRS to be operated by the HKO is vital for detecting rapidly changing high-impact weather, especially at altitudes below 1000 metres, facilitating the development of low-altitude economy and enhancing public safety. The location is optimal in view of its good coverage of the northern part of Hong Kong.

8.2 Compatible Development Scale

- 8.2.1** The proposed installation is simple and the system is designed to operate automatically. The development scale and form of the proposed project is not excessive and will be compatible with surrounding developments.

8.3 Negligible Environmental Impact

- 8.3.1** The installation has negligible environmental impact as the system is compact with small size.

8.4 No Adverse Visual Impact

- 8.4.1** The proposed PAWRS will be compact with colour compatible with the existing building, minimising visual intrusion of the proposed development to the surrounding area. The proposed project will result in no visual quality loss, no degradation to the overall landscape character and local distinctiveness of Former Lau Fau Shan Police Station and no adverse impact to the visual coherence and compositional harmony of the landscape as a whole.

9 Conclusion

The Applicant would like to install a PAWRS on the rooftop of Former Lau Fau Shan Police Station, Yuen Long, which is on top of a small hill. The proposed installation HKO is vital for detecting rapidly changing high-impact weather, especially at altitudes below 1000 metres for public safety. HKO has identified this site as a strategic location with good coverage of the northern part of the New Territories and suitable distance from the PAWRS at Qiu Yu Tan in western Shenzhen operated by the Meteorological Bureau of Shenzhen Municipality, making it an ideal location for HKO to monitor severe weather such as squall lines approaching Hong Kong from the west to northwest.

The proposed development will be compatible with the existing building of Former Lau Fau Shan Police Station and the scale of the surrounding environment and would not contravene the planning intention for this area.

The proposed development is sustainable from environmental, engineering and traffic points of view. There is no adverse visual impact to the existing building.

In view of the above, the proposed development would not set an undesirable precedent for the "G/IC" zoning. We respectfully request that the Board give favorable consideration to the proposed development and approve this application.

Appendix 1: Plan

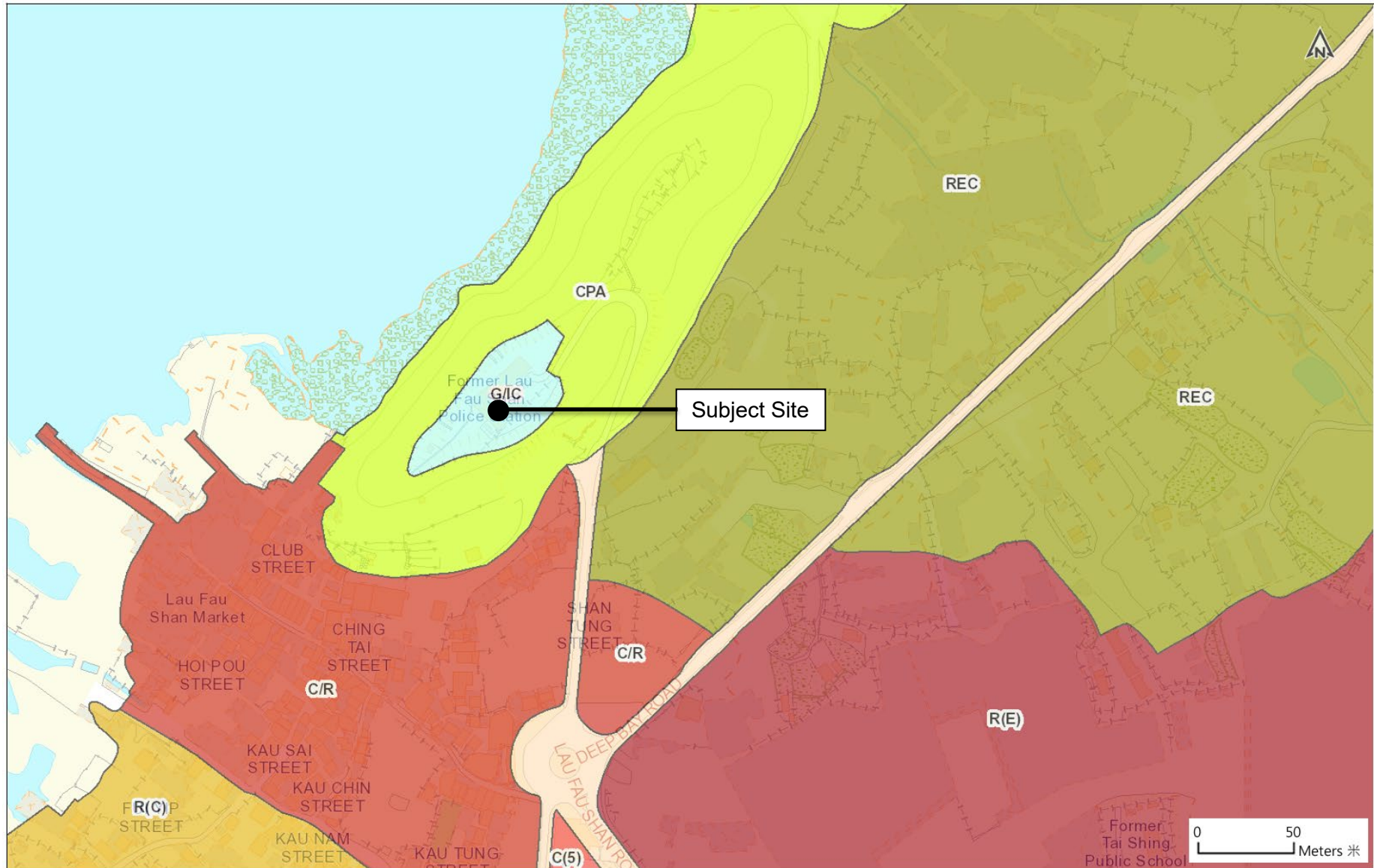

Appendix 2: Photo



Photo 1. Former Lau Fau Shan Police Station (red arrow) viewed from Lau Fau Shan Seafood Village

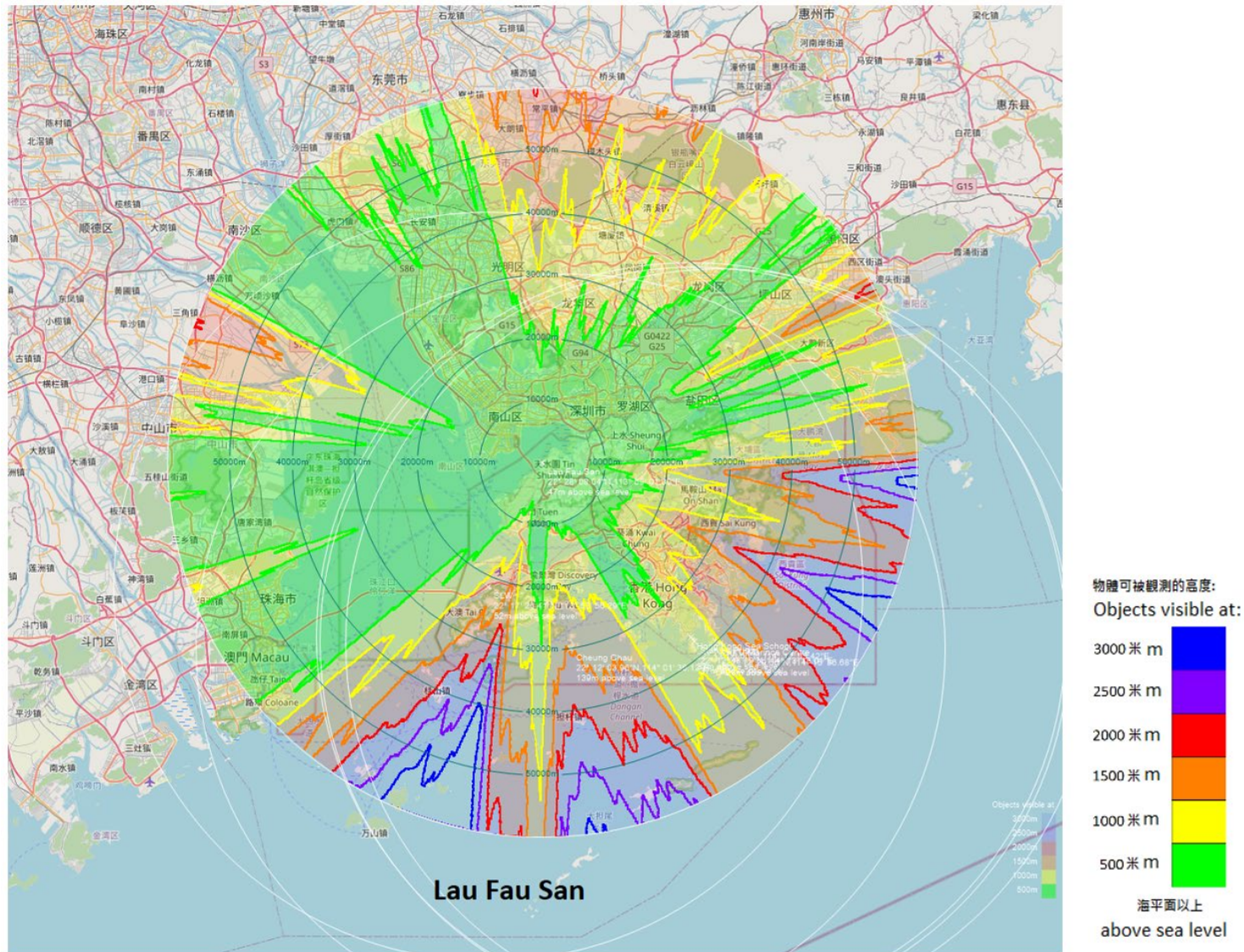

Photo 2. The Subject Site (red arrow) on top of a flushing/cleansing tank & pumps room on the rooftop of Former Lau Fau Shan Police Station

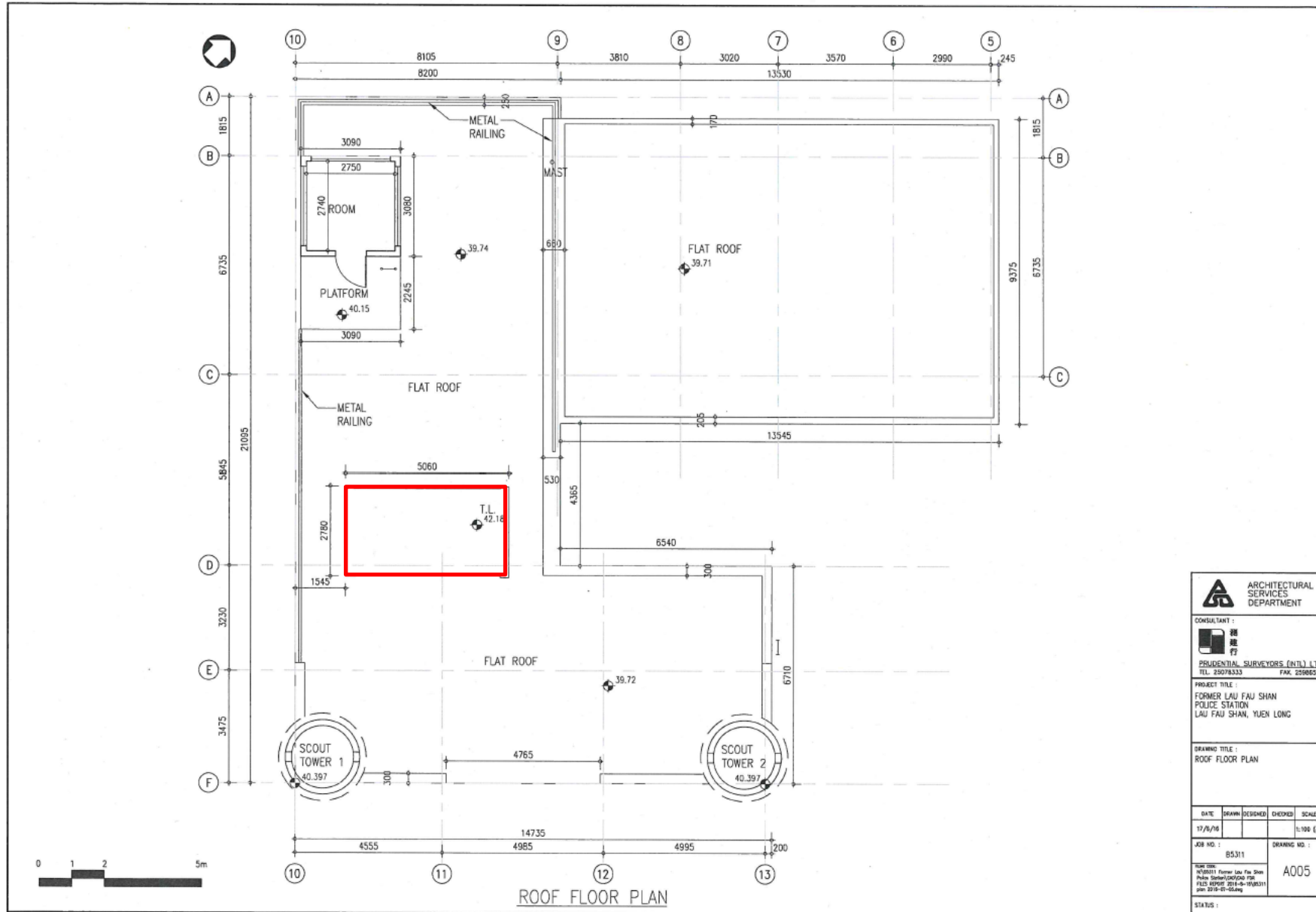

Photo 3. The existing PAWRS in Sha Lo Wan and its steel supporting frame.

Appendix 3: Drawing



Drawing 1: The radar coverage of the proposed PAWRs at the Subject Site. [green, yellow, orange, red, purple and blue contours indicate that PAWRs’s radar beams can scan atmospheric heights above 500 metres (m), 1000 m, 1,500 m, 2,000 m, 2,500 m and 3,000 m above mean sea level respectively].



Drawing 2: Location of Subject Site (red rectangle) on the rooftop of Former Lau Fau Shan Police Station.

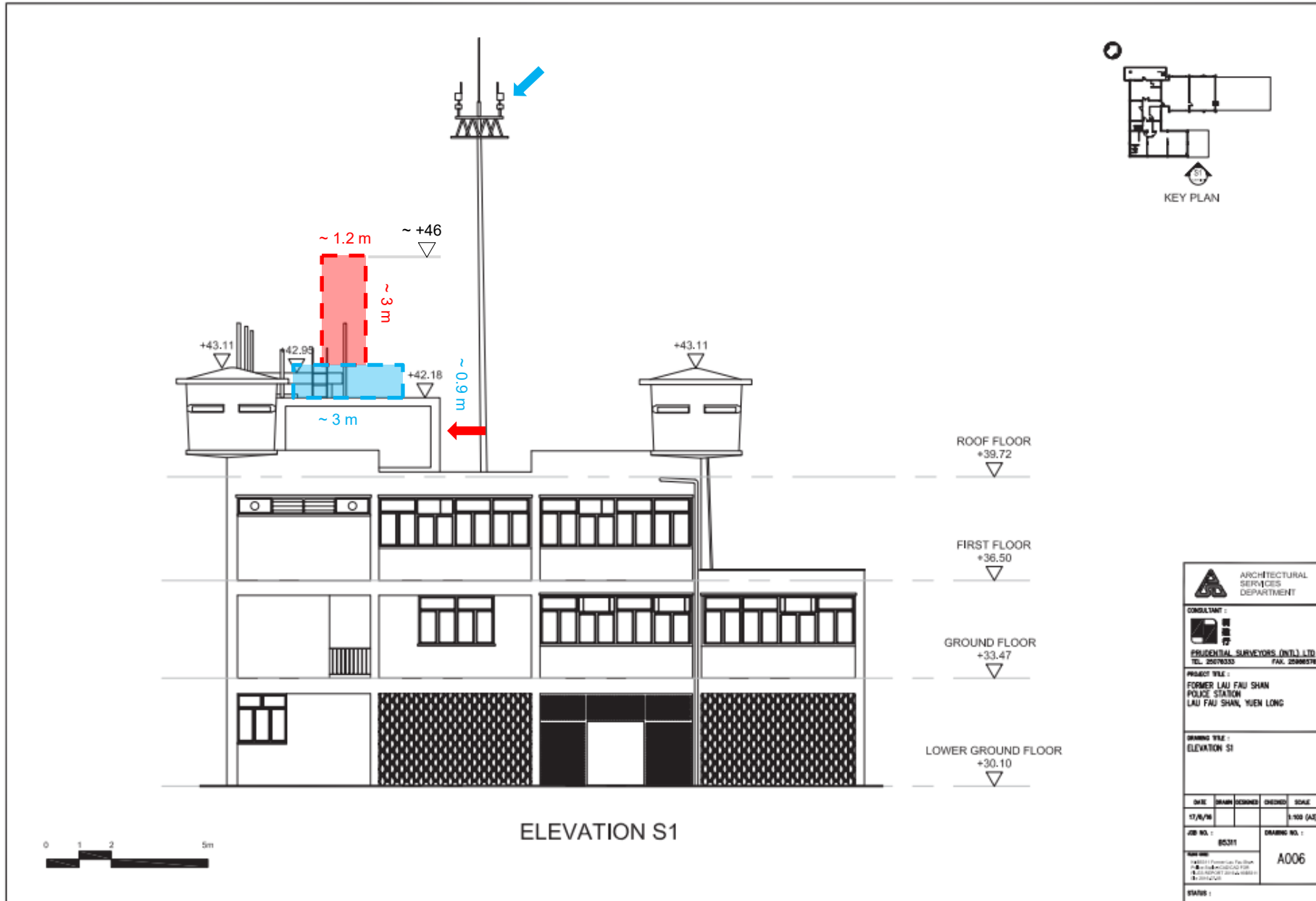

Drawing 3: Elevation levels of Former Lau Fau Shan Police Station including the Subject Site (red arrow), the proposed PAWRS (red rectangle) and its steel supporting frame (blue rectangle). The anemometer is indicated by blue arrow.

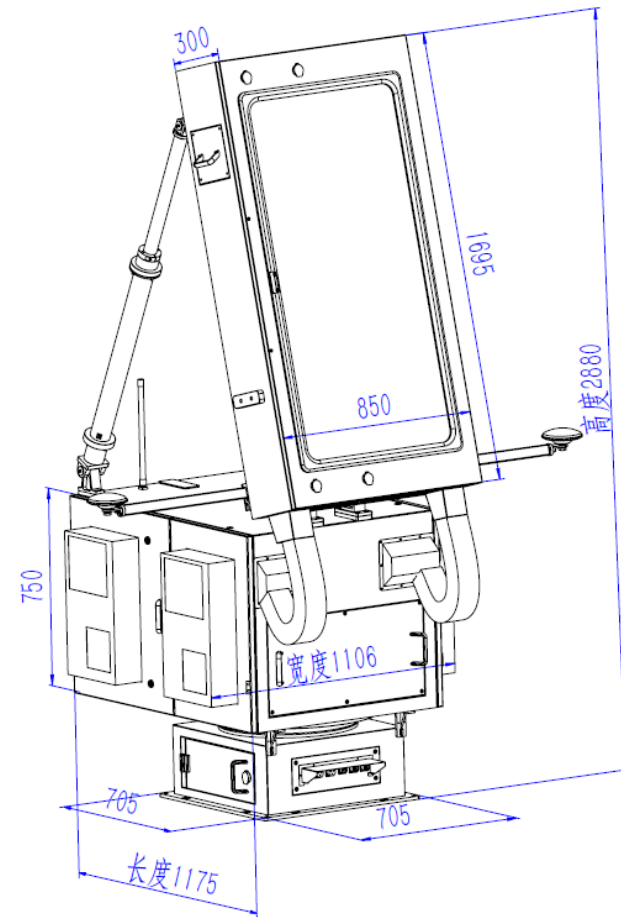

Drawing 4: Dimensions of the existing PAWRS in Sha Lo Wan.

Appendix 4: Photomontage



Photomontage 1. View from Lau Fau Shan Seafood Village.