

Appendix E

Revised Traffic Impact
Assessment

**Application for Amendment of Plan
Under Section 12A of the Town
Planning Ordinance (Cap. 131) for
Proposed Innovation and Technology
Hub at Various Lots in D.D. 82 and
D.D. 86 and Adjoining Government
Land, Man Kam To, New Territories**
Traffic Impact Assessment Report

4th Formal Submission | February 2025

This report takes into account the particular instructions and requirements of our client.

It is not intended for and should not be relied upon by any third party and no responsibility is undertaken to any third party.

Job number 287082-02

Arup Hong Kong Limited
Level 5 Festival Walk
80 Tat Chee Avenue
Kowloon Tong
Kowloon
Hong Kong
www.arup.com

ARUP

Contents

	Page
1 INTRODUCTION	1
1.1 Background	1
1.2 Objectives of this Report	1
1.3 Scope of Study	1
1.4 Structure of the Report	2
2 EXISTING TRAFFIC CONDITION	3
2.1 Site Characteristics	3
2.2 Existing Road Network	3
2.3 Existing Road Improvement Works Under Construction	3
2.4 Existing Traffic Performance	5
2.5 Existing Public Transport Facilities	8
3 THE INDICATIVE SCHEME	9
3.1 Development Schedule	9
3.2 Proposed Self-containment Arrangement	9
3.3 Proposed Vehicular and Pedestrian Access Arrangement	10
3.4 Internal Transport Facilities Provision	11
4 TRAFFIC IMPACT ASSESSMENT	18
4.1 Trip Generation and Attraction of Indicative Scheme	18
4.2 Two-Tier Transport Model	20
4.3 Planned/ Committed Developments in North District	21
4.4 Planned/ Committed Junction Improvement Schemes in North District	22
4.5 Hong Kong Major Transport Infrastructure Development Blueprint	24
4.6 Assessment Scenarios	24
4.7 Junction Capacity Assessment	24
4.8 Link Capacity Assessment	28
4.9 Public Transport Assessment	29
4.10 Railway Assessment	35
5 CONCLUSION	37
5.1 Summary	37
5.2 Conclusion	38

Figures

- Figure 1.1 Location of Application Site
- Figure 2.1 Location of Identified Key Junctions and Road Links in the Vicinity of Application Site – Overview
- Figure 2.2 Location of Identified Key Junctions and Road Links in the Vicinity of Application Site – Man Kam To / Lin Ma Hang Area
- Figure 2.3 Location of Identified Key Junctions and Road Links in the Vicinity of Application Site – Fanling Area
- Figure 2.4 Location of Identified Key Junctions and Road Links in the Vicinity of Application Site – Sheung Shui Area
- Figure 2.5 Year 2022 Existing Traffic Flow – Man Kam To / Lin Ma Hang Area
- Figure 2.6 Year 2022 Existing Traffic Flow – Sheung Shui Area
- Figure 2.7 Year 2022 Existing Traffic Flow – Queen’s Hill Area
- Figure 2.8 Public Transport Facilities in the Vicinity of Application Site
- Figure 3.1 Master Layout Plan of Indicative Scheme
- Figure 3.2 B1 Basement Layout Plan of Indicative Scheme
- Figure 3.3 B2 Basement Layout Plan of Indicative Scheme
- Figure 3.4 B3 Basement Layout Plan of Indicative Scheme
- Figure 3.5 Section Plan of Indicative Scheme
- Figure 3.6 Proposed Access Road and Signalised Junction of Indicative Scheme
- Figure 3.7 Swept Path Analysis of the Proposed Access Road and Signalised Junction of Indicative Scheme – Proposed Access Road
- Figure 3.8 Swept Path Analysis of the Proposed Access Road and Signalised Junction of Indicative Scheme – Lin Ma Hang Road Eastbound
- Figure 3.9 Swept Path Analysis of the Proposed Access Road and Signalised Junction of Indicative Scheme – Lin Ma Hang Road Westbound
- Figure 3.10 Major Ingress Vehicular Routes of Indicative Scheme
- Figure 3.11 Major Egress Vehicular Routes of Indicative Scheme
- Figure 4.1 Year 2031 Reference Traffic Flow – Man Kam To / Lin Ma Hang Area
- Figure 4.2 Year 2031 Reference Traffic Flow – Fanling Area
- Figure 4.3 Year 2031 Reference Traffic Flow – Sheung Shui Area
- Figure 4.4 Year 2031 Design Traffic Flow – Man Kam To / Lin Ma Hang Area
- Figure 4.5 Year 2031 Design Traffic Flow – Fanling Area
- Figure 4.6 Year 2031 Design Traffic Flow – Sheung Shui Area
- Figure 4.7 Proposed Junction Modification for J1 – Lin Ma Hang Road / Man Kam To Road
- Figure 4.8 Swept Path Analysis of Proposed Junction Modification for J1 – Lin Ma Hang Road / Man Kam To Road
- Figure 4.9 Proposed Junction Modification for J2 – Lin Ma Hang Road / Ping Che Road
- Figure 4.10 Swept Path Analysis of Proposed Junction Modification for J2 – Lin Ma Hang Road / Ping Che Road
- Figure 4.11 Proposed Junction Modification for J8 – Sha Tau Kok Road / Sui Wan Road
- Figure 4.12 Proposed Junction Modification for J13 – Po Shek Wu Road / Po Wan Road
- Figure 4.13 Proposed Junction Modification for J23 – San Wan Road / Fanling Station Road
- Figure 4.14 Swept Path Analysis of Proposed Junction Modification for J2 – San Wan Road / Fanling Station Road

- Figure 4.15 Proposed Routing of KMB 73K for Service Extension to the Application Site
- Figure 4.16 Proposed Routing of KMB 79K for Service Extension to the Application Site
- Figure 4.17 Proposed Layout of Terminating Facilities
- Figure 4.18 Swept Path Analysis of 12.8m long Bus between the Proposed Transport Interchange and the En-route Bus Stops
- Figure 4.19 Swept Path Analysis of 12.8m Long Bus from Internal Driveway approaching Bus Drop-Off Bay
- Figure 4.20 Swept Path Analysis of 12.8m long Bus from Internal Driveway approaching Bus Pick-up Bay 1, 3
- Figure 4.21 Swept Path Analysis of 12.8m long Bus from Internal Driveway approaching Bus Pick-up Bay 2, 4
- Figure 4.22 Swept Path Analysis of 12.8m long Bus approaching Bus Stacking Area
- Figure 4.23 Swept Path Analysis of 12.8m long Bus from Bus Stacking Area approaching Bus Pick-up Bay 1, 3
- Figure 4.24 Swept Path Analysis of 12.8m long Bus from Bus Stacking Area approaching Bus Pick-up Bay 2, 4
- Figure 4.25 Swept Path Analysis of 5m long Taxi on Taxi Stands

Appendices

Appendix A Existing Road Improvement Works under Construction

Appendix B Planned / Committed Infrastructures in North District

Appendix C Junction Calculation Sheets

Appendix D Junction Calculation Sheets for Proposed Junction Improvement

1 INTRODUCTION

1.1 Background

1.1.1 The Application Site is located at Various Lots in D.D. 82 & D.D. 86 and Adjoining Government Land, Man Kam To, New Territories. It is currently zoned as mainly in Agriculture (“AGR”), and minor parts in Green Belt (“GB”), Government, Institution or Community (“G/IC”) under the Approved Man Kam To (MKT) Outline Zoning Plan (OZP) No. S/NE-MKT/4 (the OZP). The location of Application Site is shown in **Figure 1.1**.

1.1.2 The Applicant proposes amendments to rezone the Application Site with a sizeable site area of about 125,863m² (Development site area of about 102,461m²) into an Innovation and Technology Hub with Ancillary Facilities (the “Indicative Scheme”), subject to a non-domestic gross floor area (GFA) of 365,180m², which consists of R&D Centre with 268,780m² GFA and Data Centre with 86,400m² GFA to nurture the development of I&T industry, as well as a Commercial Centre with 9,276m² to support the daily needs of the working and living population. A kindergarten of 724m² will be provided on the ground floor of Ancillary Dormitories. In addition, there will be a domestic GFA of 170,400m², which consists of Private Residential Blocks providing a total of 2,320 units together with a 3,500m² Clubhouse, and Ancillary Dormitories with 63,900m² which provide 1,392 units for the working population of R&D Centre.

1.1.3 Arup Hong Kong Limited (Arup) was commissioned to carry out a Traffic Impact Assessment (TIA) report in support of the Section 12A planning application for the proposed amendment of plan.

1.2 Objectives of this Report

1.2.1 The objective of the Study is to evaluate the potential traffic impact associated with the Proposed Innovation and Technology Hub at the Application Site.

1.3 Scope of Study

1.3.1 The tasks for this TIA study are outlined as follows:

- Carry out traffic surveys at critical junctions to appreciate current traffic condition;
- Update the inventory regarding traffic circulation patterns, traffic conditions, as well as the constraints of the existing road network in the vicinity;
- Investigate the public transport in the vicinity;
- Recommend the proposed internal transport facilities provisions;
- Set up the reference scenario should there be no Indicative Scheme at the site location, i.e. reference scenario with the existing situation;
- Assess the volume of traffic likely to be generated by the Indicative Scheme;
- Compare and evaluate the likely traffic impact, if any, associated with the Indicative Scheme; and

- Assess future traffic condition, taking into account any future traffic growth, as well as the traffic generated by the Indicative Scheme and other planned/committed development, if any, to be built in the vicinity.

1.4 Structure of the Report

1.4.1 The structure of this TIA report is as follows:

<u>Chapter</u>	<u>Title</u>	<u>Aims</u>
1	Introduction	Provide project background and scope of the Study
2	Existing Traffic Condition	Review and appreciate the existing traffic condition
3	The Subject Development	Provide information of the Indicative Scheme
4	Traffic Impact Assessment	Illustrate the results of Traffic Impact Assessment
5	Conclusion	Summarize the findings of this Study

2 EXISTING TRAFFIC CONDITION

2.1 Site Characteristics

- 2.1.1 The Application Site is located in Zone with major part in Agriculture (“AGR”), and minor parts in Green Belt (“GB”), Government, Institution or Community (“G/IC”) at Various Lots in D.D.82 & D.D.86, Man Kam To, New Territories.
- 2.1.2 The site boundary is surrounding existing Ta Ku Ling Ling Ying Public School and is bounded by existing Chow Tin Tsuen to the east and Lin Ma Hang Road to the north. **Figure 1.1** shows the location and the environs of the Application Site.

2.2 Existing Road Network

- 2.2.1 Some major roads in the vicinity of the Application Site are listed as follows:
- Lin Ma Hang Road is a rural road connecting Man Kam To Road at western end and Shan Tsui Village Road at eastern end. It is in single-two carriageway configuration for the section between Man Kam To Road and Ping Yuen River and the section between Ping Che Road and Tsung Yuen Ha, and in form of a single-track access road with passing bays for the remaining section.
 - Man Kam To Road is a rural road in single-three carriageway configuration which consists of two lanes in Northbound and one lane in Southbound. It connects Jockey Club Road at southern end and Boundary (Man Kam To Control Point) at northern end.
 - Ping Che Road is a district distributor in single-two carriageway configuration which connects Sha Tau Kok Road at southern end and Lin Ma Hang Road at northern end.
 - Heung Yuen Wai Highway is a Rural Trunk Road in dual two-lane carriageway configuration connecting the Fanling Highway and the Heung Yuen Wai Boundary Control Point (Heung Yuen Wai BCP).

2.3 Existing Road Improvement Works Under Construction

- 2.3.1 Road works under construction currently in the vicinity of the Application Site are identified as follows:
- Widening Part of Lin Ma Hang Road (Man Kam To Road to Ping Yuen River) – under CEDD project number 5758CL

The proposed road works are required to serve the anticipated traffic demand induced by the future development of innovation and technology (I&T) and related purposes at Sandy Ridge, which include widening of a section of the existing Lin Ma Hang Road of about 1.4 kilometres to a 7.3-m-wide carriageway with footpaths. The road works are anticipated to be completed in December 2022.

Site Formation and Associated Infrastructural Works for Development of Columbarium, Crematorium and Related Facilities at Sandy Ridge Cemetery

<https://www.cedd.gov.hk/eng/our-projects/major-projects/index-id-73.html>

- Widening of western section of Lin Ma Hang Road between Ping Yuen River and Ping Che Road – under HyD PWP Item 863TH

Upon the opening up of the Frontier Closed Area, the estimated traffic demand will exceed the capacity of the concerned road section. The proposed road works include (a) widening of a section of Lin Ma Hang Road of approximately 750m long between Ping Yuen River and Ping Che Road to a single two-lane carriageway with a 2m wide footpath on both sides, (b) construction of a vehicular bridge for EB traffic of approximately 70m long and 8.3m wide across Ping Yuen River and (c) a slope structure would be constructed due to the level difference of Lin Ma Hang Road eastbound and westbound carriageway between River Ganges Pumping Station and Ping Yuen River. The road works are anticipated to be completed in August 2023.

Legislative Council Panel on Transport, 863TH – Widening of Western Section of Lin Ma Hang Road Between Ping Yuen River and Ping Che Road, LC Paper No. CB(4)288/18-19(05)
(<https://www.legco.gov.hk/yr18-19/english/panels/tp/papers/tp20181214cb4-288-5-e.pdf>)

- Advance Site Formation and Engineering Infrastructure Works at Kwu Tung North (KTN) and Fanling North (FLN) New Development Area (NDA) – under CEDD project number 7747CL

The project is part of the First Phase of the KTN and FLN NDA Development, which include (a) construction of an approximately 2 km long dual two-lane Fanling Bypass Eastern Section between Shek Wu San Tsuen North and Lung Yeuk Tau comprising viaduct, at-grade road and underpass sections, (b) construction of Lung Yeuk Tau Interchange connecting Fanling Bypass Eastern Section with existing Sha Tau Kok Road – Lung Yeuk Tau, (c) construction of an approximately 2 km long dual two-lane Fanling Bypass Eastern Section between Shung Him Tong and Kau Lung Hang mainly on viaducts with two long span overbridges across the existing East Rail Line and (d) construction of local roads for First Phase Development within the KTN and FLN NDA. The Fanling Bypass Eastern Section is anticipated to be completed in Mid 2025, while the remaining road works are anticipated to be completed in Early 2026.

Advance Site Formation and Engineering Infrastructure Works at Kwu Tung North and Fanling North New Development Areas
(<https://www.cedd.gov.hk/eng/our-projects/major-projects/index-id-36.html>)

2.3.2 The corresponding Gazette Plans are attached in **Appendix A**.

2.4 Existing Traffic Performance

2.4.1 To appreciate the existing traffic conditions, comprehensive classified traffic counts were conducted at the following identified key junctions and road links in the vicinity of the Application Site. Locations of these surveyed junctions and road links are listed below and shown in **Figure 2.1** to **Figure 2.4**.

Identified Key Junctions:

J1	- Lin Ma Hang Road / Man Kam To Road	(Priority)
J2	- Lin Ma Hang Road / Ping Che Road	(Priority)
J3	- Lin Ma Hang Road / Heung Yuen Wai Highway Slip Road	(Roundabout)
J4	- Lin Ma Hang Road / Heung Yuen Wai Highway Slip Road	(Priority)
J5	- Sha Tau Kok Road / Ping Che Road	(Roundabout)
J6	- Sha Tau Kok Road / Lau Shui Heung Road	(Roundabout)
J7	- Sha Tau Kok Road / Lung Ma Road	(Roundabout)
J8	- Sha Tau Kok Road / Sui Wan Road	(Signalised)
J9	- Man Kam To Road / Kong Nga Po Road	(Priority)
J10	- Jockey Club Road / Po Wan Road	(Signalised)
J11	- Jockey Club Road / Tin Ping Road	(Signalised)
J12	- Po Shek Wu Road / Jockey Club Road	(Roundabout)
J13	- Po Shek Wu Road / Po Wan Road	(Signalised)
J14	- Po Shek Wu Road / Choi Yuen Road	(Signalised)
J15	- Lin Ma Hang Road / Proposed Access Road	(Signalised)
J16	- Sha Tau Kok Road / Fanling Bypass	(Roundabout)
J17	- Man Kam To Road / Fanling Bypass	(Roundabout)
J18	- Man Kam To Road / Road L4	(Signalised)
J19	- Sha Tau Kok Road / Luen On Street	(Signalised)
J20	- Sha Tau Kok Road / Fan Leng Lau Road	(Signalised)
J21	- Sha Tau Kok Road / Jockey Club Road	(Roundabout)
J22	- Sha Tau Kok Road / San Wan Road	(Roundabout)
J23	- San Wan Road / Fanling Station Road	(Signalised)
J24	- Jockey Club Road / So Kwun Po Road	(Signalised)
J25	- Jockey Club Road / Lung Sum Avenue	(Signalised)

Identified Key Road Links:

L1	- Lin Ma Hang Road (near Man Kam To Road junction)
L2	- Lin Ma Hang Road (near Ping Che Road junction)
L3	- Lung Shan Tunnel (Fanling Highway – Sha Tau Kok Road)
L4	- Fanling Highway (at the south of Lung Shan Tunnel)
L5	- Sha Tau Kok Road (Sui Wan Road – Ma Sik Road)
L6	- Jockey Club Road (Tin Ping Road – Po Shek Wu Road)
L7	- Po Shek Wu Road (Po Wan Road – Choi Yuen Road)
L8	- Fanling Highway (at the west of Po Shek Wu Road Interchange)
L9	- Proposed Access Road

2.4.2 The counts were undertaken on typical weekdays during the periods 07:00-10:00 and 17:00-20:00 in May 2023.

2.4.3 The AM and PM peak hours were found to be 08:00-09:00 and 17:30-18:30 respectively. The observed traffic flows during these peak hours are presented in **Figure 2.5** to **Figure 2.7**.

2.4.4 Junction capacity analysis was carried out at the identified key junctions in the vicinity of the Application Site. Results of the capacity assessment are shown in **Table 2.3.1** below.

Table 2.3.1 Year 2023 Key Junction Performance

Junction		Type	Performance ⁽¹⁾	
			AM	PM
J1	Lin Ma Hang Road / Man Kam To Road	Priority	0.29	0.27
J2	Lin Ma Hang Road / Ping Che Road	Priority	0.40	0.41
J3	Lin Ma Hang Road / Heung Yuen Wai Highway Slip Road	Roundabout	0.21	0.19
J4	Lin Ma Hang Road / Heung Yuen Wai Highway Slip Road	Priority	0.15	0.10
J5	Sha Tau Kok Road / Ping Che Road	Roundabout	0.41	0.46
J6	Sha Tau Kok Road / Lau Shui Heung Road	Roundabout	0.35	0.38
J7	Sha Tau Kok Road / Lung Ma Road	Roundabout	0.45	0.43
J8	Sha Tau Kok Road / Sui Wan Road	Signalised	41%	49%
J9	Man Kam To Road / Kong Nga Po Road	Priority	0.30	0.32
J10	Jockey Club Road / Po Wan Road	Signalised	53%	66%
J11	Jockey Club Road / Tin Ping Road	Signalised	66%	87%
J12	Po Shek Wu Road / Jockey Club Road	Roundabout	0.44	0.43
J13	Po Shek Wu Road / Po Wan Road	Signalised	43%	23%
J14	Po Shek Wu Road / Choi Yuen Road	Signalised	36%	42%
J15	Lin Ma Hnag Road / Proposed Access Road	Signalised	N.A.	
J16	Sha Tau Kok Road / Fanling Bypass	Roundabout		
J17	Man Kam To Road / Fanling Bypass	Roundabout		
J18	Man Kam To Road / Road L4	Signalised		
J19	Sha Tau Kok Road / Luen On Street	Signalised	65%	74%
J20	Sha Tau Kok Road / Fan Leng Lau Road	Signalised	33%	34%
J21	Sha Tau Kok Road / Jockey Club Road	Roundabout	0.53	0.57
J22	Sha Tau Kok Road / San Wan Road	Roundabout	0.39	0.42
J23	San Wan Road / Fanling Station Road	Signalised	22%	22%
J24	Jockey Club Road / So Kwun Po Road	Signalised	66%	57%
J25	Jockey Club Road / Lung Sum Avenue	Signalised	44%	39%

Notes:

(1) Figures shown represent “Reserve Capacity” (RC) in % for signalized junctions and “Design Flow Capacity” (DFC) ratio for roundabouts and priority junctions.

2.4.5 Results of the analysis indicate that the identified key junctions in the vicinity of the Application Site are currently operating with ample capacity during both AM and PM peak hours in Year 2023.

2.4.6 The road link capacity assessment has also been carried out to examine the volume to capacity (V/C) ratio of the assessed road links. Results of the road link assessment are shown in **Table 2.3.2** below.

Table 2.3.2 Year 2023 Key Link Performance

Link	Type ⁽¹⁾	Configuration	Direction	Capacity	Link Performance ⁽²⁾			
					AM		PM	
					Flow ⁽³⁾	V/C	Flow ⁽³⁾	V/C
L1	RR	6.75m wide Single two-lane carriageway	Two-way	1,160	410	0.36	375	0.33
L2	RR	3.5m wide single-track access road with passing bays	Two-way	600	490	0.82	455	0.76
L3	RT	Dual two-lane carriageway	NB	3,000	885	0.3	780	0.26
			SB	3,000	685	0.23	625	0.21
L4	EX	Dual four-lane carriageway	NB	8,200	6,065	0.74	5,360	0.66
			SB	8,200	5,745	0.71	5,230	0.64
L5	RR	Dual two-lane carriageway	NB	2,800	1,345	0.49	1,420	0.51
			SB	2,800	1,310	0.47	1,550	0.56
L6	PD	Dual two-lane carriageway	NB	2,800	1,080	0.39	960	0.35
			SB	2,800	1,240	0.45	1,190	0.43
L7	PD	Dual two-lane carriageway	NB	2,800	1,295	0.47	1,255	0.45
			SB	2,800	1,460	0.53	1,585	0.57
L8	EX	Dual three-lane carriageway	EB	6,100	4,970	0.82	4,710	0.78
			WB	6,100	4,950	0.82	4,275	0.71
L9	-	10.5m wide Single two-lane carriageway	Two-way	1,800	N.A.			

Notes:

- (1) Abbreviation: EX – Expressway; PD – Primary Distributor; RR – Rural Road; RT – Rural Trunk Road
- (2) A V/C ratio below 1.0 is considered acceptable. A V/C ratio above 1.0 indicates the onset of mild congestion and a V/C ratio between 1.0 and 1.2 would indicate a manageable degree of congestion. A V/C ratio above 1.2 indicates the onset of more serious congestion.
- (3) Figures are rounded to the nearest 5.

2.4.7 Results of the analysis indicate that the performance of identified key road links in the vicinity of the Application Site are considered acceptable during both AM and PM peak hours in Year 2023.

2.5 Existing Public Transport Facilities

- 2.5.1 Currently, the Application Site is only directly served by GMB Route 59K and 59S operating along Lin Ma Hang Road, which is the major feeder service between Sheung Shui Station and Lin Ma Hang / Heung Yuen Wai BCP, serving the residents of private residential developments in the vicinity and the border-crossing passengers.
- 2.5.2 Existing public transport facilities in the vicinity of the Application Site are illustrated in **Figure 2.8** and summarised in **Table 2.4.1** below.

Table 2.4.1 Existing public transport facilities in the vicinity of the Application Site

Route No.	Origin / Destination	Operation Hour	Peak Hour Headway (mins)
Green Minibus Services			
59K	Main Route: Sheung Shui Station – Lin Ma Hang	From Sheung Shui Station 05:45 am - 09:30 pm From Lin Ma Hang 06:15 am - 10:00 pm	15 - 30
	Supplementary Route: Sheung Shui Station – Heung Yuen Wai	From Sheung Shui Station 05:45 am - 08:45 pm From Heung Yuen Wai 06:15 am - 09:15 pm	30
59S	Sheung Shui Station – Heung Yuen Wai BCP	From Sheung Shui Station 06:30 am - 09:00 pm From Heung Yuen Wai BCP 07:15 am – 10:30 pm	3 - 8

- 2.5.3 In summary, the Application Site is only served by limited existing public transport services.
- 2.5.4 To improve the accessibility of the Application Site, it is proposed to provide public transport feeder services and long-haul services with sufficient transport facilities in appropriate locations for the Indicative Scheme in order to minimise the impact to the existing public transport services. Details are further discussed in **Section 4.8**.

3 THE INDICATIVE SCHEME

3.1 Development Schedule

- 3.1.1 The Applicant intends to redevelop the site into Innovation and Technology Hub together with residential, commercial and I&T use.
- 3.1.2 The Indicative Scheme is envisaged to be completed by Year 2028.
- 3.1.3 The proposed development schedule of Indicative Scheme is summarized in **Table 3.1**, and the master layout plan, preliminary layout plans for basement levels and section plans are presented in **Figure 3.1** to **Figure 3.5** respectively.

Table 3.1 Development Schedule

Development Site Area (m ²)	Type	GFA (m ²)	Flat Mix			
			No. of Blocks	Flat Size	No. of Flats	
102,461	Non-Domestic	Office (R&D Centre)	268,780	-		
		Data Centre	86,400			
		Commercial Centre	9,276			
		6-classroom Kindergarten	724			
	Domestic	Private Housing	106,500	5	~26m ²	532
					~33m ²	1,016
					~43m ²	482
					~77m ²	290
		Ancillary Dormitories	63,900	3	~26m ²	336
					~33m ²	660
~43m ²	222					
Club House	3,500 ⁽²⁾	-				

Notes:

(1) Club House is proposed to be exempted from GFA calculation.

3.2 Proposed Self-containment Arrangement

- 3.2.1 Ancillary Dormitories would be provided for application by employees of the I&T Hub (including R&D Centres and Data Centres) to achieve the Self-containment Arrangement. Flats with size < 40m² will be assigned as one-person units while flats with size > 40m² will be assigned as family units.
- 3.2.2 The walking distance and time between AD 1 and R&D 1 is anticipated to be the longest among the Ancillary Dormitories group and Office Developments group, with walking distance of approx. 500m and time of approx. 7 minutes respectively, which is considered a walkable condition and hence appropriate for self-containment assumption.
- 3.2.3 With the intention to develop an international I&T Hub, the proposed development has been designed comprehensively with R&D Centres, Data Centres, Ancillary Dormitories to be resided by IT talents and their families, and Private Residential Towers. The Ancillary Dormitories, which are purpose-built for staff working at the I&H hub, is an integral part of the I&T Hub essential to the operational needs and its overall competitiveness by attracting talent people locally and abroad.

Within the proposed I&T Hub, in addition to job opportunities, there are a Commercial Centre with retail shops and eating places, as well as a kindergarten, fulfilling the daily needs of the employees and their families without the need to travel outside. Sufficient open space (not less than 1m² per tenants of Ancillary Dormitories and residents of the private residential towers) and landscaping areas, including the 10m-wide riverside promenade, have also been provided within the I&T Hub for the enjoyment at all times. These supporting facilities will form a self-contained community where employees living in the Ancillary Dormitories will live, work, and commute within the I&T Hub.

- 3.2.4 With the self-containment arrangement, it is anticipated that the employees living in Dormitories will commute within the Application Site during weekday peak period. The associated parking demand as well as external trip generation and attraction would be low. Therefore, low-end parking provision rate and lower limit trip rate are adopted for one-person units, to avoid over-provision of parking spaces and over-estimation of external trips.
- 3.2.5 Taking into consideration of family members of the employees living in family units, high-end parking provision rate and mean trip rate are adopted for family units for conservative assessment approach.

3.3 Proposed Vehicular and Pedestrian Access Arrangement

- 3.3.1 The Application Site is located at the south of Lin Ma Hang Road near Ping Yuen River. Currently, there is no vehicular access and footpath connecting between the Application Site and the external road network.

Proposed Vehicular Access Road and Footpath

- 3.3.2 In order to provide vehicular and pedestrian access to the Application Site, the existing access road of River Ganges Pumping Station and its Substation is proposed to be widened and extended. A new standard single two-lane carriageway in width of minimum 10.5m with 2.5m-wide footpath on both sides is proposed connecting the Application Site and Lin Ma Hang Road (“Access Road”), with access point relocation of River Ganges Pumping Station and its Substation.

Proposed Signalized Junction of Lin Ma Hang Road / Access Road

- 3.3.3 In addition, signalized junction of Lin Ma Hang Road / Access Road is proposed to cater for the anticipated traffic demand arising from the Indicative Scheme.
- 3.3.4 Access Road will be further widened at junction approaches for providing additional traffic lanes to ensure the sufficient junction capacity. Despite the local road widening of Access Road, the vehicular accesses of River Ganges Pumping Station and its Substation will be maintained.
- 3.3.5 It is proposed to modify the road markings of Lin Ma Hang Road westbound carriageway to provide two traffic lanes at junction. Moreover, to ensure the junction operational performance, further widening of Lin Ma Hang Road eastbound carriageway (* without beyond the Frontier Closed Area Boundary) under the current road works by HyD PWP Item 863TH is also proposed. The slope structure in the middle of Lin Ma Hang Road carriageway between River Ganges Pumping Station and Ping Yuen River constructed under the same road works is proposed to be rearranged to facilitate the right-turn movements from the

Access Road to Lin Ma Hang Road Eastbound and right-turn movement from Lin Ma Hang Road Eastbound to the Access Road.

- 3.3.6 The proposed junction layout and swept path analysis are illustrated in **Figure 3.6** to **Figure 3.9**. The major ingress and egress routes for vehicular traffic approaching and leaving the Application Site are illustrated in **Figure 3.10** and **Figure 3.11** respectively.

3.4 Internal Transport Facilities Provision

- 3.4.1 The internal transport facilities provision for the Indicative Scheme will be provided in accordance with the high-end requirements of Hong Kong Planning Standards and Guidelines (HKPSG) and TD's Departmental Circular No. 6/2012 – Standards for Goods Vehicle Parking and Loading/Unloading for Data Centres (TD Circular No. 6/2012).
- 3.4.2 The internal transport facilities provision for the Indicative Scheme are summarized in **Table 3.4.1** to **Table 3.4.6**.

Table 3.4.1 HKPSG Required Internal Transport Provision for the Proposed Office Development (R&D Centre)

Type of Development	Facilities	HKPSG Requirement	HKPSG Required Provision		Proposed Provision
			Low-end	High-end	
Office (R & D Centre) Total GFA (m ²) 268,780	Private Car Parking	Private Car (5m (L) x 2.5m (W) x 2.4m (H))	921 (incl. accessible car parking space)	1369 (incl. accessible car parking space)	1369
		For the first 15000m ² GFA: 1 car space per 150 – 200 m ² GFA; Above 15000m ² GFA: 1 car space per 200 – 300 m ² GFA			
		Accessible Car Parking (5m (L) x 3.5m (W) x 2.4m (H))			
		6 spaces for total number of car parking spaces above 450	6	6	
	Motorcycle Parking	Motorcycle (2.4m (L) x 1m (W) x 2.4m (H))	47	137	137
		5 to 10% of the total provision for private cars with respect to each type of development should be provided			
	L/UL Bay	1 loading/unloading bay for goods vehicles for every 2000 – 3000 m ² , or part thereof, GFA	90	135	HGV: 88 LGV: 47
		TOTAL			
		LGV Loading/Unloading (7m (L) x 3.5m (W) x 3.6m (H))	59	88	
		HGV Loading/Unloading (11m (L) x 3.5m (W) x 4.7m (H))	31	47	
Lay-by for Taxis and Private Cars	Taxi/Private Car (5m (L) x 2.5m (W) x 2.4m (H))	14	14	14	
	For sites of at least 5000m ² net site area, 1 picking up/setting down lay-by for taxis and private cars for every 20000m ² , or part thereof, GFA.				

Table 3.4.2 HKPSG / TD Circular No. 6/2012 Required Internal Transport Provision for the Proposed Data Centre

Type of Development	Facilities	HKPSG / TD Circular No. 6/2012 Requirement	HKPSG Required Provision		Proposed Provision
			Low-end	High-end	
Data Centre m ² GFA 86,400	Private Car Parking ⁽¹⁾	Private Car (5m (L) x 2.5m (W) x 2.4m (H))	116 (incl. accessible car parking space)	144 (incl. accessible car parking space)	144 (incl. accessible car parking space)
		1 car space per 600 – 750 m ² GFA			
		Accessible Car Parking (5m (L) x 3.5m (W) x 2.4m (H))			
		2 spaces for 51-150 total number of car parking spaces	2	2	
	Motorcycle Parking ⁽¹⁾	Motorcycle (2.4m (L) x 1m (W) x 2.4m (H))	6	15	15
		5 to 10% of the total provision for private cars with respect to each type of development should be provided			
	L/UL Bay ⁽²⁾	For the first 20,000m ² GFA: 1 no. per 3,400 – 3,800 m ² GFA; Above 20,000m ² GFA: 1 no. per 5500 – 6100m ² GFA	17	18	LGV: 12 HGV: 6
		TOTAL			
		Loading/Unloading bays are to be provided as such: 60% for loading / unloading and 40% for parking; 65% are for LGV and 35% are for HGV			
		LGV Loading/Unloading (7m (L) x 3.5m (W) x 3.6m (H))	12	12	
		For L/UL	7	7	
		For Parking	5	5	
		HGV Loading/Unloading (11m (L) x 3.5m (W) x 4.7m (H))	5	6	
		For L/UL	3	4	
For Parking	2	2			
Lay-by for Taxis and Private Cars	Taxi/Private Car (5m (L) x 2.5m (W) x 2.4m (H))	-	-	2 ⁽³⁾	
	-				

Notes:

- (1) In accordance with HKPSG requirements.
- (2) In accordance with TD's Circular No. 6/2012 – Standards for Goods Vehicle Parking and Loading/Unloading for Data Centres.
- (3) There is no requirement of lay-by for taxis and private cars for Data Centre under HKPSG nor TD Circular No. 6/2012, lay-by provision is recommended to cater for operational need.

Table 3.4.3 HKPSG Required Internal Transport Provision for the Proposed Commercial Centre

Type of Development	Facilities	HKPSG Requirement	HKPSG Required Provision		Proposed Provision
			Low-end	High-end	
Commercial Centre m ² GFA 9,406	Private Car Parking	Private Car (5m (L) x 2.5m (W) x 2.4m (H))	31 (incl. accessible car parking space)	62 (incl. accessible car parking space)	62 (incl. accessible car parking space)
		1 car space per 150 - 300 m ² GFA			
		Accessible Car Parking (5m (L) x 3.5m (W) x 2.4m (H))			
		1 space for total number of car parking spaces below 50			
		2 spaces for 51-150 total number of car parking spaces			
	Motorcycle	Motorcycle (2.4m (L) x 1m (W) x 2.4m (H))	2	7	7
		5 to 10% of the total provision for private cars with respect to each type of development should be provided			
	L/UL Bay	1 loading/unloading bay for goods vehicles for every 800 - 1200 m ² , or part thereof, GFA	8	12	LGV: 8 HGV: 4
		TOTAL			
		LGV Loading/Unloading (7m (L) x 3.5m (W) x 3.6m (H))			
HGV Loading/Unloading (11m (L) x 3.5m (W) x 4.7m (H))					

Table 3.4.4 HKPSG Required Internal Transport Provision for the Proposed Kindergarten

Type of Development	Facilities	HKPSG Requirement	HKPSG Required Provision		Proposed Provision
			Low-end	High-end	
Kindergarten No. of Classrooms 6	Private Car Parking	Private Car (5m (L) x 2.5m (W) x 2.4m (H))	0 (incl. accessible car parking space)	2 (incl. accessible car parking space)	2
		0 to 1 car parking space per 4 to 6 classrooms			
		Accessible Car Parking (5m (L) x 3.5m (W) x 2.4m (H))			
	Lay-by for Taxis and Private Cars	Private Car/Taxi (5m (L) x 3.5m (W) x 2.4m (H))	1	2	2
		1 lay-by for taxis and private cars for every 5 to 8 classrooms			
	Lay-by for School Buses	School Bus (12m (L) x 3.5m (W) x 3.8m (H)) (OR mini-bus/nanny van (7m (L) x 3m (W) x 3.3m (H)))	2 (5)	2 (5)	2
A minimum of 2 lay-bys for school buses (OR substituted by 5 lay-bys of size 3m x 7m for mini-bus/nanny van which can provide a total number of seats equivalent to that provided by 2 large school buses)					

Table 3.4.5 HKPSG Required Internal Transport Provision for the Proposed Residential Development

Type of Development	Facilities	HKPSG Requirement		HKPSG Required Provision		Proposed Provision		
				Low-end	High-end			
Private Housing <u>No. of Flats</u> FS≤40m ² : 1,548 40m ² < FS < 70m ² : 482 70m ² < FS < 100m ² : 290 <u>No. of Blocks</u> 5	Private Car Parking	Private Car (Residential) (5m (L) x 2.5m (W) x 2.4m (H))		293 (incl. accessible car parking space)	513 (incl. accessible car parking space)	538 (incl. visitor parking space & accessible car parking space)		
		Global Parking Standard (GPS)					1 car space per 4-7 flats	
		Demand Adjustment Ratio (R1)	Flat Size (FS) (m ² GFA)				FS≤40	0.5
							40<FS≤70	1.2
							70<FS≤100	2.4
							100<FS≤130	4.1
							130<FS≤160	5.5
							FS>160	7
		Accessibility Adjustment Ratio (R2)	Within a 500m-radius of rail station				0.75	
			Outside a 500m-radius of rail station				1	
		Development Intensity Adjustment Ratio (R3)	Domestic Plot Ratio (PR)	0.00<PR≤1.00	1.3			
				1.00<PR≤2.00	1.1			
				2.00<PR≤5.00	1			
				5.00<PR≤8.00	0.9			
				PR>8.00	0.75			
Parking Requirement = GPS x R1 x R2 x R3								
		Private Car (Visitors) (5m (L) x 2.5m (W) x 2.4m (H))		25	25			
		5 visitor spaces per block in addition to the recommendations, or as determined by the Authority						
		Accessible Car Parking (5m (L) x 3.5m (W) x 2.4m (H))		4	6			
		4 spaces for 251-350 total number of car parking spaces						
		6 spaces for total number of car parking spaces above 450						
		TOTAL Private Car Parking (5m (L) x 2.5m (W) x 2.4m (H))		318	538			
				(incl. accessible car parking space)	(incl. accessible car parking space)			
Motorcycle Parking	Motorcycle (2.4m (L) x 1m (W) x 2.4m (H))		16	24	24			
	1 motorcycle parking space per 100-150 flats excluding non-residential elements							
L/UL Bay	HGV Loading/Unloading (11m (L) x 3.5m (W) x 4.7m (H))		5	5	5			
	Minimum of 1 loading/unloading bay for goods vehicles within the site for every 800 flats or part thereof, subject to a minimum of 1 bay for each housing block or as determined by the Authority							

Table 3.4.6 HKPSG Required Internal Transport Provision for the Proposed Ancillary Dormitories

Type of Development	Facilities	HKPSG Requirement		HKPSG Required Provision		Proposed Provision		
				Low-end	High-end			
Ancillary Dormitories <u>No. of Flats⁽¹⁾</u> FS≤40m ² : 996 40m ² < FS <70m ² : 222 70m ² < FS <100m ² : 174 <u>No. of Blocks</u> 3	Private Car Parking	Private Car (Residential) (5m (L) x 2.5m (W) x 2.4m (H))		One-person	One-person	258⁽¹⁾ (incl. visitor parking space & accessible car parking space)		
		Global Parking Standard (GPS)		1 car space per 4-7 flats	<u>Unit</u> 72		<u>Unit</u> 125	
		Demand Adjustment Ratio (R1)	Flat Size (FS) (m ² GFA)	FS≤40	0.5		<u>Family Unit</u> 97	<u>Family Unit</u> 171
				40<FS≤70	1.2			
				70<FS≤100	2.4			
				100<FS≤130	4.1			
				130<FS≤160	5.5			
				FS>160	7			
		Accessibility Adjustment Ratio (R2)	Within a 500m-radius of rail station		0.75		Total 169 (incl. accessible car parking space)	Total 296 (incl. accessible car parking space)
			Outside a 500m-radius of rail station		1			
		Development Intensity Adjustment Ratio (R3)	Domestic Plot Ratio (PR)	0.00<PR≤1.00	1.3		Total 169 (incl. accessible car parking space)	Total 296 (incl. accessible car parking space)
				1.00<PR≤2.00	1.1			
				2.00<PR≤5.00	1			
				5.00<PR≤8.00	0.9			
				PR>8.00	0.75			
Parking Requirement = GPS x R1 x R2 x R3								
Private Car (Visitors) (5m (L) x 2.5m (W) x 2.4m (H))		5 visitor spaces per block in addition to the recommendations, or as determined by the Authority		15	15			
Accessible Car Parking (5m (L) x 3.5m (W) x 2.4m (H))		3 spaces for 151-250 total number of car parking spaces		3	4			
		4 spaces for 251-350 total number of car parking spaces						
TOTAL Private Car Parking (5m (L) x 2.5m (W) x 2.4m (H))				184	311			
				(incl. accessible car parking space)	(incl. accessible car parking space)			
Motorcycle Parking ⁽¹⁾	Motorcycle (2.4m (L) x 1m (W) x 2.4m (H))		<u>Single Flat</u> 7	<u>Single Flat</u> 10	11⁽¹⁾			
	1 motorcycle parking space per 100-150 flats excluding non-residential elements		<u>Family Flat</u> 3	<u>Family Flat</u> 4				
L/UL Bay	HGV Loading/Unloading (11m (L) x 3.5m (W) x 4.7m (H))		3	3	3			
	Minimum of 1 loading/unloading bay for goods vehicles within the site for every 800 flats or part thereof, subject to a minimum of 1 bay for each housing block or as determined by the Authority							

Notes:

(1) As referred to the self-containment arrangement in Section 3.2

3.4.3 The proposed total provision of internal transport facilities of the Indicative Scheme is summarized in **Table 3.4.7** below.

Table 3.4.7 Summary of Proposed Total Internal Transport Facilities Provision

Facilities (L x W H)	Development Use	Proposed Provision
Private Car Parking Space (5m x 2.5m x 2.4m)	Office (R&D Centre)	1,369
	Data Centre	144
	Commercial Centre	62
	Kindergarten	2
	Private Housing	538
	Ancillary Dormitories	258
	Total (incl. visitor parking space & accessible car parking space)	2,373
Accessible Car Parking Space (5m x 3.5m x 2.4m)	Office (R&D Centre)	6
	Data Centre	2
	Commercial Centre	2
	Kindergarten	1
	Private Housing	6
	Ancillary Dormitories	3
	Total	20
Motorcycle Parking Space (2.4m x 1m x 2.4m)	Office (R&D Centre)	137
	Data Centre	15
	Commercial Centre	7
	Private Housing	24
	Ancillary Dormitories	11
	Total	194
LGV Loading/Unloading Bay (7m x 3.5m x 3.6m)	Office (R&D Centre)	88
	Data Centre	12
	Commercial Centre	8
	Total	108
HGV Loading/Unloading Bay (11m x 3.5m x 4.7m)	Office (R&D Centre)	47
	Data Centre	6
	Commercial Centre	4
	Private Housing	5
	Ancillary Dormitories	3
	Total	65
Lay-by for Taxis and Private Cars (5m x 2.5m x 2.4m)	Office (R&D Centre)	14
	Data Centre	2
	Kindergarten	2
	Total	18
Lay-by for School Buses (12m x 3.5m x 3.8m)	Kindergarten	2
	Total	2

- 3.4.4 The proposed internal transport facilities for the Indicative Scheme will be self-contained within the respective site boundary, located on ground floor and basement parking floors of the Indicative Scheme.

Private Car Parking Space Provision

- 3.4.5 A total of 2,373 nos. private car parking spaces (including 20 nos. accessible car parking spaces) as per HKPSG high-end requirements (except one-person unit of Ancillary Dormitories which adopted HKPSG low-end requirements) will be provided in the basement levels, which will be accessed via the car-ramp system of basement of corresponding type of development.

Accessible Car Parking Provision

- 3.4.6 A total of 20 nos. accessible car parking spaces (part of the 2,358 private car parking spaces), as per HKPSG high-end requirements will be provided in the basement levels, which will be accessed via the car-ramp system of basement of corresponding type of development.

Motorcycle Parking Space Provision

- 3.4.7 A total of 194 nos. motorcycle parking spaces as per HKPSG high-end requirements will be provided in the basement levels, which will be accessed via the car-ramp system of basement of corresponding type of development.

Loading / Unloading Bay Provision

- 3.4.8 A total of 108 nos. loading/unloading bays for LGV and 65 nos. loading/unloading bays for HGV as per HKPSG high-end requirement and recommended provision will be provided in both the basement levels and ground floors of corresponding type of development.

Lay-by Provision for Taxis and Private Cars

- 3.4.9 A total of 18 nos. lay-bys for taxis/private cars as per HKPSG high-end requirement and recommended provision will be provided on ground floor of corresponding type of development.

Lay-by Provision for School Buses

- 3.4.10 A total of 2 nos. lay-bys for school buses as per HKPSG high-end requirement will be provided on ground floor of corresponding School.

4 TRAFFIC IMPACT ASSESSMENT

4.1 Trip Generation and Attraction of Indicative Scheme

Data Centre

- 4.1.1 To establish appropriate trip generation and attraction rates for Data Centre of the Indicative Scheme, trip generation survey has been conducted on typical weekdays at various existing data centre developments as summarised in **Table 4.1.1**.

Table 4.1.1 Peak Hour Trip Generation and Attraction at the Surveyed Data Centres

Development		AM Peak		PM Peak	
		Generation	Attraction	Generation	Attraction
NTT Hong Kong Financial Data Centre at 6 Chun Kwang St, Tseung Kwan O (70,000 m ² GFA)	Observed Trips (pcu/hr)	34.1	27.7	17.95	8.1
	Trip Rate (pcu/hr/100 sqm GFA)	0.049	0.040	0.026	0.012
iTech Tower 1 at 28 Pak Tin Par Street, Tsuen Wan (17,652m ² GFA)	Observed Trips (pcu/hr)	2.1	1	2	1
	Trip Rate (pcu/hr/100 sqm GFA)	0.012	0.006	0.011	0.006
iTech Tower 2 at 54-56 Ta Chuen Ping Street, Kwai Chung (9,125m ² GFA)	Observed Trips (pcu/hr)	2.5	3.5	2	0
	Trip Rate (pcu/hr/100 sqm GFA)	0.027	0.038	0.022	0.000
NTT Hong Kong Tai Po Data Centre at 2 Dai Hei Street, Tai Po (19,700 m ² GFA)	Observed Trips (pcu/hr)	9	6.1	7.1	13
	Trip Rate (pcu/hr/100 sqm GFA)	0.046	0.031	0.036	0.066

- 4.1.2 For conservative assessment, the highest of the rates above were adopted for applying to Data Centre of the Indicative Scheme, as shown in **Table 4.1.2** below.

Other types of Developments

- 4.1.3 The likely amount of traffic generation and attraction associated with the Indicative Scheme, except Data Centre, was calculated based on the mean values of ‘Traffic Rates for Residential Development at 95% Confidence Level’ and ‘Traffic Rates for Non-residential Development at 95% Confidence Level’ adopted in the TPDM Vol. 1 Table 1 and Table 2.
- 4.1.4 Public transport feeder service with ancillary transport facilities in appropriate locations, including terminating facilities and en-route bus stops, has been proposed to/from the railway stations and bus interchange as discussed in **Section 4.8**. It is anticipated that the feeder service is significant to enhance the convenience for residents/ employees using public transport services. The Indicative Scheme would be well-served by public transport services to cater for the effect of “remote site”. It is hence considered that “Mean” value is appropriate to be adopted. The adopted rates are shown in **Table 4.1.2** below.

Table 4.1.2 Adopted Trip Generation and Attraction Rates of the Indicative Scheme

Sources	Component		AM Peak		PM Peak	
			Generation	Attraction	Generation	Attraction
In-house surveys	Data Centre (pcu/hr/100 sqm GFA)		0.049	0.040	0.036	0.066
TPDM Vol. 1	Housing	Lower Limit, Average Flat Size 40sqm (pcu/flat/hr)	0.0325	0.0213	0.0196	0.0263
		Mean, Average Flat Size 50sqm (pcu/flat/hr)	0.0622	0.0426	0.0297	0.0401
		Mean, Average Flat Size 60sqm (pcu/flat/hr)	0.0718	0.0425	0.0286	0.0370
		Mean, Average Flat Size 80sqm (pcu/flat/hr)	0.1058	0.0605	0.0426	0.0590
	Office, Mean (pcu/hr/100 sqm GFA)		0.1703	0.2452	0.1573	0.1175
	Retail, Mean (pcu/hr/100 sqm GFA)		0.2296	0.2434	0.3100	0.3563

4.1.5 The peak traffic arriving and leaving the kindergarten are generally observed and occurred before school start time (i.e. 8am) and school finish time (i.e. 5pm) which will not overlap with the daily commuting AM and PM peak hours. For conservative approach, nominal school-related traffic flows 10 pcu/hr have been considered and superimposed on the traffic forecast for the same daily commuting AM and PM peak hours for assessment purpose.

4.1.6 The associated traffic generation and attraction for the Indicative Scheme are summarised in **Table 4.1.3**.

Table 4.1.3 Traffic Generation and Attraction of the Indicative Scheme (pcu/hr)

Type of Development	AM Peak		PM Peak	
	Generation	Attraction	Generation	Attraction
Office (R&D Centre)	305	439	282	211
Data Centre	43	35	32	58
Commercial Centre	22	23	29	34
Kindergarten	10	10	10	10
Private Housing	177	104	71	93
Ancillary Dormitories ⁽¹⁾	65	42	34	46
Additional bus trips ⁽²⁾	50	50	50	50
Total	672	703	508	502

Notes:

(1) As referred to the self-containment arrangement in Section 3.2

(2) Based on the existing bus enhancement proposal by double-decked bus as discussed in Section 4.9

4.1.7 As indicated in table above, the total trips would be around 1,375 pcu/hr and 1,010 pcu/hr (two-way) during the AM and PM peak periods respectively.

4.2 Two-Tier Transport Model

4.2.1 The Indicative Scheme is targeted for completion in Year 2028. In order to assess the traffic impact of the development-related traffic on the adjacent road network, Year 2031 (i.e., 3 years after completion) is adopted as the design year of the study.

4.2.2 In view of the large population intake and the significant forecasted traffic generation and attraction of the Indicative Scheme, two levels of transport models are adopted. The Strategic Transport Model (STM) is at the upper tier. At the lower tier, it contains the Local Area Traffic Model (LATM).

Strategic Transport Model Structure

4.2.3 The STM is a link-based transport model which produces transport demand forecasts at strategic and inter-district levels. It is mainly to estimate the transport demand of the district-to-district movements by different private and public transport modes with respect to the infrastructures of the whole territory.

4.2.4 The STM follows the conventional 4-step modelling approach, comprising trip generation, trip distribution, modal split and trip assignment. The model produces passenger and vehicular flows on the transport network system by time periods of the day. This model offers the advantage to reflect the traffic demand forecasts especially the mode choice with respect to the fundamental assumptions such as the socio-economic and infrastructures.

4.2.5 The strategic and inter-district vehicular demand from the STM forms the primary input to the LATM.

Local Area Traffic Model Structure

4.2.6 The LATM is a junction-based assignment model which stimulates the local area traffic demand at intra-district level. With the incorporation of local area junction characteristics, the LATM is capable of estimating the junction delay and traffic queuing for route choice in assigning the traffic demand in local areas.

4.2.7 The development of LATM adopts the same approach as TD's 2019-based Base District Traffic Model (BDTM) with forecast year of 2031. The LATM is a peak hour trip assignment model which contains two components: (i) the "trip matrix" which specifies the number of AM peak/ PM peak hour trips from zone *i* to zone *j*; and (ii) the "network" which specifies the physical structure of the road links and junctions etc. upon which trips take place. Both the matrix and network are fed into a "route choice" model which allocates trips to "routes" through the network through the model assignment process.

4.2.8 There are three types of vehicles represented in the LATM. They are Private Vehicles (PV), Goods Vehicles (GV) and road-based public transport (PT) services. PV and GV are fed into the model in form of trip matrices, while PT vehicles are fixed route services and pre-loaded to the network.

4.2.9 The LATM matrices are developed from the cordoned matrices extracted from the STM, with the same LATM coverage of the model area. The compatibility between the STM and the LATM is ensured by the control of the external trip ends, which are essentially the link flows of major roads along the cordon. In other words, the LATM is consistent with the STM in terms of the socio-economic, transport infrastructure and road network assumptions.

- 4.2.10 The LATM matrices are developed from the cordoned matrices extracted from the STM, with the same LATM coverage of the model area. The compatibility between the STM and the LATM is ensured by the control of the external trip ends, which are essentially the link flows of major roads along the cordon. In other words, the LATM is consistent with the STM in terms of the socio-economic, transport infrastructure and road network assumptions.
- 4.2.11 Evaluations of link and junction performance for the Traffic Impact Assessment will be conducted based on the traffic forecast result from LATM.

Model Validation

- 4.2.12 As the road network and traffic flow in 2019-based BDTM are only validated to base Year 2019, the LATM has been further validated to latest traffic condition based on the observed traffic flows during peak hours obtained from traffic count survey dated May 2023 on identified key junctions and road links as summarized in Para. 2.4.1 with their locations indicated in Figure 2.1 to Figure 2.4, taking into account the latest traffic aids, junction layouts and method of control in the study area. The validation criteria of base year 2023 LATM adopted in this study is consistent with TD's BDTM.

4.3 Planned/ Committed Developments in North District

- 4.3.1 In addition to the development flow, the traffic generated and attracted by adjacent major planned/committed developments which would anticipatedly induce traffic implication on the identified key junctions/ road links have been taken into account for the traffic forecast.
- 4.3.2 Under the 2019-based BDTM, the major planned / committed developments incorporated in design year 2031 BDTM trip matrices are listed in **Table 4.3.1**.

Table 4.3.1 Planned / Committed Developments in North District under 2019-based BDTM

Type of Development		Ref. Index in BDTM
KTN/ FLN NDA	Various Lots in D.D. 51, D.D. 83, D.D. 95 and D.D. 96 and Adjoining Government Land in Fanling North and Kwu Tung North, New Territories	P18-5-2
	CDA site Hang Tau Tai Po, Kwu Tung South (Y/NE-KTS/13)	P19-5-9 & P19-5-11
	CDA site to the west of Hang Tau Road, Kwu Tung South (Y/NE-KTS/15)	P19-5-3
Public / Subsidised Housing	Sheung Shui Areas 4 and 30	HN10 & HN11
	Ching Ho Estate Extension (Phase 4)	HN21
	Po Shek Wu Road	HN12
	Pak Wo Road (A/FSS/254)	B19-5-5
	Queen's Hill Extension	HN37
Private Housing	Residential Development at Ma Sik Road, Area 18, Fanling Sheung Shui Town Lot No. 262 (<i>Private Housing</i>)	P19-5-10
	Ling Hill (Y/FSS/18)	P19-5-8
Commercial	1 Lun Fat Street	B18-5-7

- 4.3.3 Apart from the major planned / committed developments incorporated in the design year 2031 BDTM trip matrices, the following major planned / committed

developments have been further incorporated into the traffic forecast and summarized in **Table 4.3.2** below.

Table 4.3.2 Planned / Committed Developments in North District

Type of Development		Tentative Completion Year
KTN/ FLN NDA	“CDA(2)” Kam Hang Road, Kwu Tung South (Y/NE-KTS/14)	2025
	Yin Kong CDA (Y/KTN/2)	2026
	“CDA(1)” Lot 2579 in D.D. 92, Kam Hang Road (A/NE-KTS/506)	2027
Public / Subsidised Housing	Fanling Area 15 East Phase 1 & 2 (No. A/FLN/28) ⁽¹⁾	2025/26
	Jockey Club Road	2025/26
	Fanling Area 48	2029
	Ching Hiu Road	2028/29
	Choi Shun Street	2029/30
	San Wan Road	2026/27
	Fanling Area 17 Site A	2031/32
Traditional Housing	“Pok Oi Sing Ping Village” at Ping Che Road, Ta Kwu Ling (No. A/NE-TKL/692)	2024
Private Housing	1 Lun Fat Street (No. A/FSS/282) ⁽²⁾	2025
	Fanling Area 40 (Y/FSS/13)	2027/28
	Sheung Shui Lot 2 RP (Oi Yuen) (Y/FSS/19)	2028
	“R(A)12” at Ma Sik Road (No. A/FSS/294) ⁽³⁾	2029
	Fanling Area 17 Sites B1 and B2	2030/31
Others	North District Hospital Extension	2028
	New Territories East Cultural Centre	2027/28
	Community Health Centre cum Social Welfare Facilities at Pak Wo Road	2024
	Social Welfare Facility (Residential Care Home for the Elderly) and Flat (A/FSS/288)	2031
	Kong Nga Po Police Training Facilities	2026/27

Notes:

- (1) Same site with Planned Development Ref. Index “P18-5-2” incorporated in BDTM. Only additional trip generation/attraction due to the increased nos. of flats from this application are further included in the traffic forecast
- (2) Same site with Planned Development Ref. Index “B18-5-7” incorporated in BDTM. Only additional trip generation/attraction due to the additional land use of private residential development with 119 nos. of flats from this application are further included in the traffic forecast
- (3) Same site with Planned Development Ref. Index “P19-5-8” incorporated in BDTM. Only additional trip generation/attraction due to the increased nos. of flats from this application are further included in the traffic forecast

4.4 Planned/ Committed Junction Improvement Schemes in North District

4.4.1 As North District is undergoing numerous planned large-scale developments, apart from the ongoing road improvements works as aforementioned in **Chapter 2.3**, transportation infrastructures have been planned and anticipated to be completed before the completion of the Indicative Scheme. Associated Road/Junction Improvement works to be completed beyond May 2023 which would anticipatedly induce traffic implication on the identified key junctions/ road links have been taken into account for the traffic forecast and summarised in **Table 4.4.1**.

Table 4.4.1 Planned/ Committed Infrastructures/ Junction Improvement Schemes in North District

Description		Proposed by Project	Tentative Completion Year	
Transports Infrastructures	<p><u>CEDD Project Number 7835CL</u> (Source: https://www.cedd.gov.hk/eng/our-projects/major-projects/index-id-87.html)</p> <ul style="list-style-type: none"> - Construction Fanling Bypass Western Section - Widening of Fanling Highways between Chau Tau and Po Shek Wu Interchange from dual-three lane to dual-four lane - Provision of Po Shek Wu Road Flyover linking Po Shek Wu Road (Po Wan Road – Choi Yuen Road) and Fanling Highway (Kwu Tung Section) WB <p>Construction of local roads for Remaining Phase Development within the KTN/ FLN NDA area</p>		KTN/ FLN NDA	Before 2031
	Po Shek Wu Road/ Po Wan Road (J13)	<ul style="list-style-type: none"> - Lane arrangement of Po Shek Wu Road southbound to be revised for allowing straight-ahead traffic to use three traffic lanes - Lane arrangement of Po Wan Road eastbound to be revised for allowing right-turn traffic to use two traffic lanes - Land arrangement of Po Shek Wu Road northbound to be revised for allowing left-turn traffic to use two traffic lanes - Local widening of Po Wan Road westbound from 1 to 2 lanes 	Kong Nga Po Sheung Shui Areas 4 and 30	Completed
Junction Improvement Schemes	Po Shek Wu Road/ Choi Yuen Road (J14)	<ul style="list-style-type: none"> - Local widening of entry arm of Po Shek Wu Road NB to allow straight-ahead traffic to use three traffic lanes - Po Shek Wu Road Interchange Improvement which provides a flyover to allow the right turning traffic from Po Shek Wu Road SB to Fanling Highway WB to bypass the existing Po Shek Wu Road Interchange - Entry arm of Po Shek Wu Road SB would be narrowed from 5 lanes to 4 lanes 	Kong Nga Po KTN/ FLN NDA	2023 (not yet completed) 2029
	Jockey Club Road/ So Kwun Po Road (J24)	<ul style="list-style-type: none"> - Lane arrangement of Jockey Club Road northbound to be revised for allowing left turn traffic to use two traffic lanes - Method-of-control to be revised for minimising/optimising the intergreen time - Lane arrangement of Ma Sik Road southbound to be revised for allowing three traffic lanes for vehicles to travel straight ahead - Local widening of So Kwun Po Road southbound from 2 to 3 lanes - Local widening with one additional straight-ahead traffic lane on So Kwun Po Road northbound - Local widening of Ma Sik Road northbound from 2 to 3 lanes 	KTN/ FLN NDA Sheung Shui Areas 4 and 30	2023 (not yet completed)
	Jockey Club Road/ Lung Sum Avenue (J25)	<ul style="list-style-type: none"> - Local widening with one additional straight-ahead traffic lane on Jockey Club Road eastbound - Local widening with one additional straight-ahead traffic lane on Lung Sum Avenue northbound 	Kong Nga Po	Completed

4.4.2 The corresponding discussion paper of the planned/ committed junction improvement schemes is attached in **Appendix B**.

4.5 Hong Kong Major Transport Infrastructure Development Blueprint

- 4.5.1 The Government has promulgated the “Hong Kong Major Transport Infrastructure Development Blueprint” (The Blueprint) in December 2023 with a view to meeting the city’s long-term transport and logistics needs up to 2046 and beyond. One of the proposals included in The Blueprint is the additional “Two Railways & One Major Road”, which is related to North District and comprises the Northern Link Eastern Extension (NOLE), the Northeast New Territories Line (NENTL), and the Northern Metropolis Highway (New Territories North New Town Section).
- 4.5.2 NOLE will extend the Northern Link eastward from Kwu Tung Station to Ping Che and is planned connect to NENTL at its terminal. Based on the preliminary alignment illustrated in The Blueprint, NOLE will pass by the southern edge of the Applicate Site without encroaching its boundary. Hence, it is anticipated that the Indicative Scheme will not have interface issue with NOLE, subject to the finalised design of NOLE.
- 4.5.3 On the other hand, with the consideration that there is no information about the station location and the operation year of NOLE, the traffic and transport impact have been assessed with the assumption that NOLE is not yet available at the time of population intake of the Indicative Scheme for conservative approach.

4.6 Assessment Scenarios

- 4.6.1 To evaluate the traffic impact likely to be induced by the traffic associated with the Indicative Scheme, two scenarios are analysed and compared. **Scenario 1** is the Reference Scenario (without the Indicative Scheme) in Year 2031. **Scenario 2** is the Design Scenario (with the Indicative Scheme) in Year 2031.

Scenario 1

Year 2031 Reference Scenario

= Adjusted Year 2031 Two-Tier Transport Model traffic flows

Plus traffic generations of major planned/committed developments in the vicinity not incorporated in 2019-based BDTM

Scenario 2

Year 2031 Design Scenario

= Year 2031 Reference Scenario

Plus trip generation and attraction associated with the Indicative Scheme as indicated in **Table 4.1.3**

- 4.6.2 The forecasted traffic flows for the above two scenarios are presented in **Figure 4.1** to **Figure 4.6**.

4.7 Junction Capacity Assessment

- 4.7.1 Junction capacity assessment was carried out at the identified key junctions for Year 2031 Reference and Design Scenarios. Assessment results are summarized in **Table 4.7.1** below. The detailed junction calculation sheets are attached in **Appendix C**.

Table 4.7.1 Year 2031 Future Junction Performance

Junction	Type	Performance ⁽¹⁾				
		2031 Reference		2031 Design		
		AM	PM	AM	PM	
J1	Lin Ma Hang Road / Man Kam To Road	Priority	0.39	0.47	0.87	0.82
J2	Lin Ma Hang Road / Ping Che Road	Priority	0.57	0.68	1.26	1.09
J3	Lin Ma Hang Road / Heung Yuen Wai Highway Slip Road	Roundabout	0.30	0.31	0.46	0.42
J4	Lin Ma Hang Road / Heung Yuen Wai Highway Slip Road	Priority	0.24	0.18	0.53	0.36
J5	Sha Tau Kok Road / Ping Che Road	Roundabout	0.53	0.58	0.62	0.64
J6	Sha Tau Kok Road / Lau Shui Heung Road	Roundabout	0.48	0.49	0.54	0.53
J7	Sha Tau Kok Road / Lung Ma Road	Roundabout	0.56	0.64	0.59	0.67
J8	Sha Tau Kok Road / Sui Wan Road	Signalised	6%	17%	1%	11%
J9	Man Kam To Road / Kong Nga Po Road	Priority	0.49	0.53	0.63	0.60
J10	Jockey Club Road / Po Wan Road	Signalised	51%	46%	26%	28%
J11	Jockey Club Road / Tin Ping Road	Signalised	52%	53%	28%	39%
J12	Po Shek Wu Road / Jockey Club Road	Roundabout	0.52	0.53	0.64	0.62
J13	Po Shek Wu Road / Po Wan Road ⁽²⁾	Signalised	32%	29%	10%	16%
J14	Po Shek Wu Road / Choi Yuen Road ⁽²⁾	Signalised	33%	38%	21%	31%
J15	Lin Ma Hnag Road / Proposed Access Road	Signalised	-	-	28%	49%
J16	Sha Tau Kok Road / Fanling Bypass	Roundabout	0.56	0.55	0.59	0.59
J17	Man Kam To Road / Fanling Bypass	Roundabout	0.56	0.58	0.73	0.70
J18	Man Kam To Road / Road L4	Signalised	58%	67%	32%	44%
J19	Sha Tau Kok Road / Luen On Street	Signalised	37%	39%	30%	33%
J20	Sha Tau Kok Road / Fan Leng Lau Road	Signalised	31%	28%	29%	26%
J21	Sha Tau Kok Road / Jockey Club Road	Roundabout	0.59	0.65	0.62	0.67
J22	Sha Tau Kok Road / San Wan Road	Roundabout	0.45	0.47	0.47	0.49
J23	San Wan Road / Fanling Station Road	Signalised	10%	10%	7%	8%
J24	Jockey Club Road / So Kwun Po Road	Signalised	33%	36%	31%	34%
J25	Jockey Club Road / Lung Sum Avenue	Signalised	39%	32%	36%	29%

Notes:

- (1) Figures shown represent “Reserve Capacity” (RC) in % for signalized junctions and “Design Flow Capacity” (DFC) ratio for roundabouts and priority junctions.
- (2) With implementation of infrastructures/ junction improvement works as discussed in Section 2.3/ 4.4

4.7.2 The results revealed that all the identified key junctions would operate within capacity with the Indicative Scheme in Year 2031, except J1, J2, J8, J13 and J23.

4.7.3 Considering that the junction capacity for junction J1 – Lin Ma Hang Road / Man Kam To Road would be operated near capacity during AM peak period under Year 2031 Design Scenario, J2 – Lin Ma Hang Road / Ping Che Road would be overloaded during both AM and PM peak period under Year 2031 Design Scenario, J8 – Sha Tau Kok Road / Sui Wan Road would be operated near capacity during AM peak period under both Year 2031 Reference and Design Scenario as well as during PM peak period under Year 2031 Design Scenario, J13 – Po Shek Wu Road / Po Wan Road would be operated near capacity during AM peak period under Year 2031 Design Scenario, and J23 – San Wan Road / Fanling Station Road would be operated near capacity during both AM and PM peak period under both Year 2031 Reference and Design Scenario, improvement proposals have been explored to improve the performance of the junctions.

J1 - Lin Ma Hang Road / Man Kam To Road

4.7.4 Under the existing junction arrangement, Lin Ma Hang Road is currently operated as the minor arm of the priority junction with right and left turning traffic share the same single lane for queuing.

- 4.7.5 It is considered that right turning traffic has a longer average queuing time than left turning traffic to leave the minor arm as right turning traffic requires to wait for major stream traffic of Man Kam To Road both bounds while left turning traffic requires to wait for major arm traffic of Man Kam To Road southbound only. It may cause unnecessary delay for left turning traffic which is anticipated much more significant than right turning traffic upon the commissioning of the Indicative Scheme. As a result, it is proposed to provide a flare lane to allow right and left turning traffic queuing at separate lanes, as presented in **Figure 4.7** with corresponding swept path analysis presented in **Figure 4.8**.

J2 - Lin Ma Hang Road / Ping Che Road

- 4.7.6 Under the existing junction arrangement, Lin Ma Hang Road is currently operated as the minor arm of the priority junction.
- 4.7.7 Upon the commissioning of the Indicative Scheme, it is anticipated that traffic flow on Lin Ma Hang Road will become the major traffic movement of this junction. Therefore, it is proposed to modify the junction configuration by classifying Lin Ma Hang Road and Ping Che Road as the major arm and the minor arm of the junction respectively as presented in **Figure 4.9** to suit the future traffic pattern, with corresponding swept path analysis presented in **Figure 4.10**.

J8 - Sha Tau Kok Road / Sui Wan Road

- 4.7.8 Under the existing Method of Control arrangement (MOC), there is one exclusive stage for right-turn movement from Sha Tau Kok Road NB to Sui Wan Road EB, which limit the green time for straight-ahead movement along Sha Tau Kok Road.
- 4.7.9 Upon the commissioning of the Indicative Scheme as well as the Queen's Hill Extension, it is anticipated that straight-ahead traffic flow along Sha Tau Kok Road will be more significant of this junction. Therefore, it is proposed to improve the junction by, (1) banning of right-turn movements at Sui Wan Road WB, (2) banning of left-turn movements at Sui Wan Road EB, (3) banning of right-turn movements at both Sha Tau Kok Road NB and SB, (4) road marking modification of far-side traffic lane of approaching arm of Sha Tau Kok Road SB to provide a new straight-ahead traffic lane, and (5) road marking modification of Sha Tau Kok Road NB far-side traffic lane and rearrangement of central divider/ traffic island of Sha Tau Kok Road near the concerned junction J8 to provide a new traffic lane of leaving arm of Sha Tau Kok Road SB with approx. 50m weaving length. The proposed junction improvement scheme with proposed MOC is presented in **Figure 4.11**.
- 4.7.10 Affected traffic would use J7 – Sha Tau Kok Road/ Lung Ma Road Roundabout and J16 – Future Sha Tau Kok Road / Fanling Bypass Roundabout for resuming to Sui Wan Road and Sha Tau Kok Road. In view of the detoured traffic volume and travelling distance, the resultant traffic diversion is considered immaterial.

J13 - Po Shek Wu Road / Po Wan Road

- 4.7.11 Alternatively, local widening for exit arm of Po Shek Wu Road NB to allow straight-ahead traffic to use three lanes is proposed. With the consideration that left-turn traffic is much less significant than straight-ahead traffic, it is proposed to rearrange the lane movement to fit in the aforementioned local widening, such that nearside lane will be shared by left-turn traffic and straight-ahead traffic, while 2nd and 3rd lane will allow straight-ahead traffic only.

4.7.12 Furthermore, subsequent to the implementation of local widening of exit arm of Po Shek Wu Road SB, local widening of entry arm of Po Shek Wu Road SB is further proposed such that there would be three exclusive lanes for straight-ahead traffic and one exclusive lanes for left-turn traffic.

4.7.13 The proposed junction improvement scheme is presented in **Figure 4.12**.

J23 - San Wan Road / Fanling Station Road

4.7.14 Under the existing junction arrangement, the nearside lane from San Wan Road EB is exclusively for left-turn traffic. As the corresponding exit arm is only an access road to Cheung Wah Estate, the left-turn traffic flow volume is significantly low and such lane arrangement is not optimised. With the consideration that both straight-ahead traffic and right-turn traffic are the major traffic movement for San Wan Road EB, it is proposed to maintain the existing lane arrangement for right-turn traffic but share the nearside lane for straight-ahead traffic. Lane warning line road marking is further proposed to guide the straight-ahead movement to enhance the vehicular safety. The proposed junction improvement scheme is presented in **Figure 4.13**. corresponding swept path analysis at the junction is presented in **Figure 4.14**.

4.7.15 With the proposed junction improvement / modification, the junction J2, J7, J8, J13, J16 and J23 have been reassessed and the corresponding junction performance is summarized in **Table 4.7.2** below. The detailed junction calculation sheets for the proposed junction improvement schemes are attached in **Appendix D**.

Table 4.7.2 Year 2031 Future Junction Performance – With Junction Improvement / Modification

Junction		Type	2031 Design Performance ⁽¹⁾			
			Without Junction Improvement		With Junction Improvement	
			AM	AM	PM	PM
J1	Lin Ma Hang Road / Man Kam To Road	Priority	0.87	0.82	0.84	0.80
J2	Lin Ma Hang Road / Ping Che Road	Priority	1.26	1.09	0.71	0.65
J7	Sha Tau Kok Road / Lung Ma Road ⁽²⁾	Roundabout	0.59	0.67	0.62	0.71
J8	Sha Tau Kok Road / Sui Wan Road	Signalised	1%	11%	28%	29%
J13	Po Shek Wu Road / Po Wan Road	Signalised	10%	16%	28%	26%
J16	Sha Tau Kok Road / Fanling Bypass ⁽²⁾	Roundabout	0.59	0.59	0.61	0.60
J23	San Wan Road / Fanling Station Road	Signalised	7%	8%	24%	24%

Notes:

(1) Figures shown represent “Reserve Capacity” (RC) in % for signalized junctions and “Design Flow Capacity” (DFC) ratio for priority junctions.

(2) With the proposed junction improvement of J8

4.7.16 The above results revealed that under the Design Scenario in Year 2031, the DFC of J1 would be improved from 0.87 to 0.84 and 0.82 to 0.80 during AM peak and PM peak periods respectively, the DFC of J2 would be improved from 1.26 to 0.71 and 1.09 to 0.65 during AM peak and PM peak periods respectively, the RC of J8 would be improved from 1% to 28% and 11% to 29% during AM peak and PM peak periods respectively, the RC of J13 would be improved from 10% to 28% and 16% to 26% during AM peak and PM peak periods respectively, and the RC of J23 would be improved from 7% to 24% and 8% to 24% during AM peak and PM peak periods respectively.

4.7.17 On the other hand, due to the diverted traffic by the proposed junction modification of J8, the DFC of J7 would be slightly increase from 0.59 to 0.62 and 0.67 to 0.71 during AM peak and PM peak periods respectively, while the DFC of J16 would be slightly increase from 0.59 to 0.61 and 0.59 to 0.60 during AM peak and PM

peak periods respectively. It is hence anticipated that the traffic implication to J7 and J16 associated with the proposed junction modification of J8 is immaterial.

- 4.7.18 With the above improvement proposal, it is anticipated that the performance of junction J1, J2, J8, J13 and J23 would be enhanced, and all junctions would be operated within capacity with the Indicative Scheme in Year 2031.

4.8 Link Capacity Assessment

- 4.8.1 Key road links within the study area are identified and assessed in both Reference and Design scenarios in Design Year 2031. Assessment results are summarised in **Table 4.8.1** below.

Table 4.8.1 Year 2031 Future Link Performance

Link	Type ⁽¹⁾	Configuration	Direction	Capacity	Link Performance ⁽²⁾								
					2031 Reference				2031 Design				
					AM		PM		AM		PM		
					Flow ⁽³⁾	V/C	Flow ⁽³⁾	V/C	Flow ⁽³⁾	V/C	Flow ⁽³⁾	V/C	
L1	Lin Ma Hang Road (near Man Kam To Road junction) ⁽⁴⁾	RR	7.3m wide Single two-lane carriageway	Two-way	1,500	545	0.37	555	0.37	1,240	0.83	1,070	0.72
L2	Lin Ma Hang Road (near Ping Che Road junction) ⁽⁴⁾	RR	7.3m wide Single two-lane carriageway	Two-way	1,500	700	0.47	710	0.48	1,420	0.95	1,250	0.84
L3	Lung Shan Tunnel (Fanling Highway – Sha Tau Kok Road)	RT	Dual two-lane carriageway	NB	3,000	1,380	0.46	980	0.33	1,550	0.52	1,075	0.36
				SB	3,000	1,210	0.41	1,160	0.39	1,345	0.45	1,280	0.43
L4	Fanling Highway (at the south of Lung Shan Tunnel)	EX	Dual four-lane carriageway	NB	8,200	5,155	0.63	6,145	0.75	5,375	0.66	6,280	0.77
				SB	8,200	7,660	0.94	6,470	0.79	7,840	0.96	6,625	0.81
L5	Sha Tau Kok Road (Sui Wan Road – Fanling Bypass)	RR	Dual two-lane carriageway	NB	2,800	1,730	0.62	1,990	0.72	1,835	0.66	2,090	0.75
				SB	2,800	2,045	0.74	1,775	0.64	2,175	0.78	1,855	0.67
L6	Jockey Club Road (Tin Ping Road – Po Shek Wu Road)	PD	Dual two-lane carriageway	NB	2,800	1,135	0.41	1,065	0.39	1,465	0.53	1,320	0.48
				SB	2,800	1,370	0.49	1,415	0.51	1,690	0.61	1,650	0.59
L7	Po Shek Wu Road (Po Wan Road – Choi Yuen Road)	PD	Dual two-lane carriageway	NB	2,800	1,700	0.61	1,655	0.60	1,995	0.72	1,860	0.67
				SB	2,800	1,985	0.71	2,100	0.75	2,250	0.81	2,300	0.83
L8	Fanling Highway (at the west of Po Shek Wu Road Interchange) ⁽⁴⁾	EX	Dual four-lane carriageway	EB	8,200	6,055	0.74	6,060	0.74	6,320	0.78	6,230	0.76
				WB	8,200	5,880	0.72	4,975	0.61	6,120	0.75	5,160	0.63
L9	Proposed Access Road	-	10.5m wide Single two-lane carriageway	Two-way	1,800	-	-	-	-	1,380	0.77	1,010	0.57

Notes:

- (1) Abbreviation: EX – Expressway; PD – Primary Distributor; RR – Rural Road; RT – Rural Trunk Road
- (2) A V/C ratio below 1.0 is considered acceptable. A V/C ratio above 1.0 indicates the onset of mild congestion and a V/C ratio between 1.0 and 1.2 would indicate a manageable degree of congestion. A V/C ratio above 1.2 indicates the onset of more serious congestion.
- (3) Figures are rounded to the nearest 5.
- (4) With implementation of infrastructures/ junction improvement works as discussed in Section 2.3/ 4.4

- 4.8.2 The above results revealed that all key road links assessed will be performing satisfactorily with spare capacity in both Reference and Design scenarios in Year 2031.

4.8.3 Similar to junction performance, due to the diverted traffic by the proposed junction modification of J8, L5 has been reassessed and the corresponding link performance is summarized in **Table 4.8.2** below.

Table 4.8.2 Year 2031 Future Link Performance – With Junction Improvement / Modification

Link	Type (1)	Configuration	Direction	Capacity	2031 Design Performance (2)							
					Without Junction Improvement				With Junction Improvement			
					AM		PM		AM		PM	
					Flow (3)	V/C	Flow (3)	V/C	Flow (3)	V/C	Flow (3)	V/C
L5 Sha Tau Kok Road (Sui Wan Road – Fanling Bypass)	RR	Dual two-lane carriageway	NB	2,800	1,835	0.66	2,090	0.75	1,880	0.68	2,135	0.77
			SB	2,800	2,175	0.78	1,855	0.67	2,220	0.80	1,900	0.68

Notes:

- (1) Abbreviation: EX – Expressway; PD – Primary Distributor; RR – Rural Road; RT – Rural Trunk Road
- (2) A V/C ratio below 1.0 is considered acceptable. A V/C ratio above 1.0 indicates the onset of mild congestion and a V/C ratio between 1.0 and 1.2 would indicate a manageable degree of congestion. A V/C ratio above 1.2 indicates the onset of more serious congestion.
- (3) Figures are rounded to the nearest 5.

4.8.4 The above results revealed that the V/C ratio of Sha Tau Kok Road (Sui Wan Road – Fanling Bypass) Northbound would be slightly increase from 0.66 to 0.68 and 0.75 to 0.77 during AM peak and PM peak periods respectively, while the V/C ratio of Sha Tau Kok Road (Sui Wan Road – Fanling Bypass) Southbound would be slightly increase from 0.78 to 0.80 and 0.67 to 0.68 during AM peak and PM peak periods respectively. It is hence anticipated that the traffic implication to L5 associated with the proposed junction modification of J8 is immaterial.

4.9 Public Transport Assessment

4.9.1 The anticipated population of the Private Housing and family units of the ancillary dormitories of the Indicative Scheme is about 6,264 and 1,070 respectively, while the anticipated working population is 6,207. According to “Travel Characteristics Survey (TCS) 2011” published by Transport Department, the daily mechanised trip rate is 1.83 trips per person, while both morning and evening peak hour accounted for about 12% of the daily trips. It is hence estimated that the Indicative Scheme would induce 1,611 resident passengers / hour (i.e. $7,334 \times 1.83 \times 0.12$) and 1,364 worker passengers / hour (i.e. $6,207 \times 1.83 \times 0.12$) during the peak period. For conservative approach, a factor of 1.2 is further applied on the peak hour passenger trips (i.e. $1,611 \times 1.2 = 1,933$ & $1,364 \times 1.2 = 1,637$) which deems sufficient to consider the unforeseen growth as well as the non-resident / non-worker users of the R&D Centre, Data Centre, Commercial Centre and kindergarten. The anticipated passenger trips in the peak hour is summarized in **Table 4.9.1**.

Table 4.9.1 Passenger Trips Generation / Attraction of the Indicative Scheme during peak period

Development Parameters	Residents	Workers
No. of private residential units & family units in dormitories (1)	2,716 flats	N.A.
Population	7,334 (2)	6,207
Peak Hour Passenger Trips	1,933 pax/hr	1,637 pax/hr

Notes:

- (1) Assuming single flats in dormitories will not generate / attract trips to external road network during daily commuting peaks as discussed in Section 3.2
- (2) Average domestic household size of 2.7 is assumed based on the 2021 Population Census in North District.

4.9.2 The modal split for residents in North District extracted from Table B203 and C204 under District Council District “North” from 2021 Population Census published by Census and Statistics Department is summarised in **Table 4.9.2**.

Table 4.9.2 Main Mode of Transport to Place of Study and Work in North District

Mode of Transport	Place of Study (from B203)	Place of Work (from C204)	Total	
	Persons	Persons	Persons	%
MTR (Local line)	12,118	46,153	58,271	39.0%
Bus	8,238	22,781	31,019	21.0%
On foot only	12,822	11,285	24,107	16.0%
School bus	4,145	-	4,145	3.0%
Public light bus	3,541	7,802	11,343	8.0%
Private car/ Passenger van	3,400	7,887	11,287	7.5%
Company bus/ van	-	3,002	3,002	2.0%
MTR (Light Rail)	-	-	-	-
Taxi	214	711	925	0.5%
Residential coach service	489	580	1,069	0.5%
Ferry/ Vessel	-	18	18	0.0%
Others	888	3,212	4,100	2.5%
Total	45,855	103,431	149,286	100%

4.9.3 With the consideration of the locality of the Application Site, it is assumed that company bus/van, residential coach service, and ferry/vessel are not the available for the residents of the Indicative Scheme, and the associated passenger trips will be evenly distributed into MTR and bus.

4.9.4 On the other hand, in order to minimise the disturbance of the residents from private residential developments in the vicinity as well as the border crossing passengers using the existing GMB 59K and 59S services, it is assumed that public light bus is also not available for the residents of the Indicative Scheme, with the consideration that service enhancement of GMB is not efficient due to its low carrying capacity. The associated passenger trips will be distributed into bus. The adjusted modal split for the Indicative Scheme is summarized in **Table 4.9.3**.

Table 4.9.3 Adjusted Modal Split for resident passengers of the Indicative Scheme

Original Passenger Trip at North District	Adjusted Modal Split for resident passengers of the Indicative Scheme							
	MTR (Local line)	Bus	School bus	Taxi	Private car/ Passenger van	On foot only	Others	Total
MTR (Local line)	58,271							58,271
Franchised Bus		31,019						31,019
On foot only						24,107		24,107
School bus			4,145					4,145
Public light bus		11,343						11,343
Private car/ Passenger van					11,287			11,287
Company bus/ van	1,501	1,501						3,002
MTR (Light Rail)	-	-						-
Taxi				925				925
Residential coach service	535	534						1,069
Ferry/ Vessel	9	9						18
Others							4,100	4,100
Total	60,316	44,406	4,145	925	11,287	24,107	4,100	149,286
Proportion	40.25%	30.25%	3.0%	0.5%	7.5%	16.0%	2.5%	100.0%

4.9.5 With the consideration that school bus would not be available for worker passengers, the 3% school bus modal split would be evenly distributed into MTR and bus similar to the adjustment on modal split for residents. The associated passenger demand for resident passengers and worker passengers of the Indicative Scheme in peak hour is estimated in **Table 4.9.4**.

Table 4.9.4 Estimated Passenger Demand from Indicative Scheme in Peak Hour

Mode of Transport	Residents		Workers	
	Proportion	Passenger Demand (pax/hr)	Proportion	Passenger Demand (pax/hr)
MTR (Local line)	40.25%	778	41.75%	683
Franchised Bus	30.25%	585	31.75%	520
School bus	3.0%	58	-	-
Taxi	0.5%	10	0.5%	8
Private car/ Passenger van	7.5%	145	7.5%	123
On foot only	16.0%	309	16.0%	262
Others	2.5%	48	2.5%	41
Total	100%	1,933	100%	1,637

4.9.6 Although there is no existing franchised bus route operating along the section of Lin Ma Hang Road outside the Application Site, currently there are KMB 73K and KMB 79K operating along Man Kam To Road and Ping Che Road respectively, which are anticipated the major ingress and egress vehicular routes of the Application Site connecting MTR stations and major Bus-Bus Interchange (BBI) in Sheung Shui and Fanling. In order to avoid duplication of public transport services in terms of routings and to better utilise the existing bus resources, the Applicant proposes to extend the services of KMB 73K and KMB 79K to the Application Site instead of introducing new franchised bus routes.

4.9.7 The proposed routings of KMB 73K and KMB 79K are illustrated in **Figure 4.15** and **Figure 4.16** respectively. The proposed bus service extension would act as feeder services which not only cater for MTR passenger demand, but also cater for long-haul bus passenger demand from the Indicative Scheme, by interchanging with existing long-haul bus routes in Sheung Shui BBI and Fanling Station BBI.

4.9.8 The projected travel distance between the Application Site and the nearest Railway Station / BBI (i.e. Sheung Shui Station for KMB 73K and Fanling Station for KMB 79K) of KMB 73K and KMB 79K is approx. 8 km and 14 km respectively. Under the observed average speed of respective bus route as mentioned in **Table 4.9.13**, the projected journey time of KMB 73K is 30 mins, while that of KMB 79K is 62 mins respectively, which is nearly double. It is hence considered the passengers induced by the Indicative Scheme would prefer KMB 73K over KMB 79K. For assessment purpose, it is assumed the nos. of passengers of KMB 73K and KMB 79K would have a same ratio with their projected journey time, hence 2/3 of them taking KMB 73K (i.e. $1,363 \times 2/3 = 909$ for residents, $1,203 \times 2/3 = 802$ for workers) and remaining 1/3 (i.e. $1,363 - 909 = 454$ for residents, $1,203 - 802 = 401$ for workers) taking KMB 79K is derived such that nos. of passengers of KMB 73K would be double to that of KMB 79K.

4.9.9 To identify if there are spare capacity to cope with the passenger demand induced by the Indicative Scheme, current occupancy of KMB 73K and KMB 79K at identified critical bus stops during morning and evening peak periods are surveyed and summarised from **Table 4.9.5** to **Table 4.9.8**, including **Sheung Shui Wai / Po Shek Wu Road Sheung Shui** and Fung Kai No.1 Secondary School for KMB 73K, **Kwan Tei**, Luen Wo Hui Bus Terminus and Fanling Station for KMB 79K.

Table 4.9.5 Observed Bus Occupancy of KMB 73K at Sheung Shui Wai / Po Shek Wu Road Sheung Shui

Hour	Sheung Shui Bound				Man Kam To Bound			
	No. of Bus Trips	Total Capacity*	Total Passengers	Occupancy	No. of Bus Trips	Total Capacity*	Total Passengers	Occupancy
0700 – 0800	3	225	109	48%	4	300	176	59%
0800 – 0900	3	225	86	38%	3	225	135	60%
0900 – 1000	3	225	48	21%	3	225	52	23%
1700 – 1800	3	225	90	40%	3	225	70	31%
1800 – 1900	3	225	112	50%	3	225	96	43%
1900 – 2000	2	150	47	21%	3	225	111	49%

Note:

* Assumed Bus Capacity is 75 passengers per vehicle as single-decked buses are employed

Table 4.9.6 Observed Bus Occupancy of KMB 73K at Fung Kai No.1 Secondary School

Hour	Sheung Shui Bound				Man Kam To Bound			
	No. of Bus Trips	Total Capacity*	Total Passengers	Occupancy	No. of Bus Trips	Total Capacity*	Total Passengers	Occupancy
0700 – 0800	3	225	105	47%	4	300	182	61%
0800 – 0900	3	225	95	42%	3	225	130	58%
0900 – 1000	3	225	41	18%	3	225	59	26%
1700 – 1800	3	225	116	52%	3	225	75	33%
1800 – 1900	3	225	134	60%	3	225	87	39%
1900 – 2000	2	150	41	27%	3	225	102	45%

Note:

* Assumed Bus Capacity is 75 passengers per vehicle as single-decked buses are employed

Table 4.9.7 Observed Bus Occupancy of KMB 79K at Kwan Tei / Luen Wo Hui Bus Terminus

Hour	Sheung Shui Bound (Luen Wo Hui Bus Terminus for AM Peak, Kwan Tei for PM Peak)				Ta Kwu Ling Bound (Luen Wo Hui Bus Terminus)			
	No. of Bus Trips	Total Capacity*	Total Passengers	Occupancy	No. of Bus Trips	Total Capacity*	Total Passengers	Occupancy
0700 – 0800	3	360	135	38%	2	240	69	29%
0800 – 0900	3	360	81	23%	3	360	123	34%
0900 – 1000	3	360	107	30%	3	360	118	33%
1700 – 1800	3	360	129	36%	2	240	94	39%
1800 – 1900	2	240	77	32%	2	240	162	68%
1900 – 2000	2	240	58	24%	3	360	155	43%

Note:

* Assumed Bus Capacity is 120 passengers per vehicle as double-decked buses are employed

Table 4.9.8 Observed Bus Occupancy of KMB 79K at Fanling Station

Hour	Sheung Shui Bound				Ta Kwu Ling Bound			
	No. of Bus Trips	Total Capacity*	Total Passengers	Occupancy	No. of Bus Trips	Total Capacity*	Total Passengers	Occupancy
0700 – 0800	3	360	96	27%	2	240	51	21%
0800 – 0900	3	360	76	21%	3	360	74	21%
0900 – 1000	3	360	74	21%	3	360	59	16%
1700 – 1800	3	360	87	24%	3	360	82	23%
1800 – 1900	2	240	65	27%	3	360	84	23%
1900 – 2000	2	240	37	15%	3	360	172	48%

Note:

* Assumed Bus Capacity is 120 passengers per vehicle as double-decked buses are employed

4.9.10 It is considered that the usage of franchised buses is hugely related to planned population and employment within its catchment area. Reference was hence made to 2019-based Territorial Population and Employment Data Matrix (TPEDM) published by Planning Department. **Table 4.9.9** and **Table 4.9.10** below summarize the estimated and projected population and employment data in 2019, 2026 and 2031 as well as the respective annual average growth rate of Planning Data District (PDD) “Fanling/Sheung Shui” and Sub-region “NENT” which is formed by a number of PDDs, including Fanling/Sheung Shui, Tai Po, Ma On Shan, Sha Tin and Other Area in NENT.

Table 4.9.9 Annual Average Growth Rate of Fanling/Sheung Shui by TPEDM

	2019 Estimates	2026 Projection	2031 Projection	Annual Growth Rate from 2019 to 2031
Population	258,300	274,100	352,350	2.62%
Employment	64,100	66,650	79,400	1.80%
TOTAL	322,400	340,750	431,750	2.46%

Table 4.9.10 Annual Average Growth Rate of NENT by TPEDM

	2019 Estimates	2026 Projection	2031 Projection	Annual Growth Rate from 2019 to 2031
Population	1,316,700	1,431,950	1,547,650	1.36%
Employment	421,000	411,500	438,000	0.33%
TOTAL	1,737,700	1,843,450	1,985,650	1.12%

4.9.11 From the above tables, the average annual growth rate determined from Fanling/Sheung Shui in TPEDM ranges from 1.80% to 2.62% p.a. and that from NENT in TPEDM ranges from 0.33% to 1.36% p.a.. For conservative assessment purpose, the highest growth factor (i.e. +2.62% p.a.) would be applied to the observed highest nos. of franchised bus passengers to forecast the franchised bus passenger demand in Design Year 2031.

4.9.12 The passenger movement of residents and workers from the Indicative Scheme is anticipated having a mutually exclusive characteristic (i.e. during AM peak, the major passenger groups taking public transport to approach the Site would be working population from the proposed R&D Centre, Data Centre, Commercial Centre and Kindergarten living outside, while the major passenger groups taking public transport to leave the Site would be residential population from private housing development and the family members from ancillary dormitories, and vice versa during PM peak period). It is hence considered that the major passenger trips between residential population and working population would not overlap with each other in the perspective of travel direction (i.e. would not take the bus towards the same direction). As such, resident passenger trips would be distributed into KMB 73K (Sheung Shui bound) (i.e. 909 pax/hr) and KMB 79K (Sheung Shui bound) (i.e. 454 pax/hr) respectively while worker passenger trips would be distributed into KMB 73K (Man Kam To bound) (i.e. 802 pax/hr) and KMB 79K (Ta Kwu Ling bound) (i.e. 401 pax/hr) respectively during AM peak, and vice versa during PM peak.

4.9.13 The highest usage of Sheung Shui bound and Man Kam To/Ta Kwu Ling bound during AM peak and PM peak for KMB 73K and KMB 79K is highlighted in **Table 4.9.5** to **Table 4.9.8**. By adopting the growth rate of +2.62% p.a. into the observed highest nos. of passengers, the estimated passengers demand of KMB 73K and KMB 79K in Year 2031 were summarised in **Table 4.9.11**.

Table 4.9.11 Estimated Passenger Demand of KMB 73K and KMB 79K in Year 2031

Bus Route	Peak Period	Direction	2023 Observed Peak Franchised Bus Passenger Demand (pax/hr)	2031 Reference Peak Franchised Bus Passenger Demand (pax/hr)	Additional Public Transport demand by Indicative Scheme (pax/hr) *	2031 Design Peak Franchised Bus Passenger Demand (pax/hr)
KMB 73K	AM	Sheung Shui	109	131	909	1040
		Man Kam To	182	218	802	1020
	PM	Sheung Shui	134	161	802	963
		Man Kam To	111	133	909	1042
KMB 79K	AM	Sheung Shui	135	162	454	616
		Ta Kwu Ling	123	147	401	548
	PM	Sheung Shui	129	155	401	556
		Ta Kwu Ling	172	206	454	660

Note:

* Distributed into specific bound as referred to Para. 4.9.12

4.9.14 Based on the above table, it is anticipated that there would be insufficient spare capacity for both KMB 73K and KMB 79K under their respective existing headway. Hence, it is proposed to enhance the service by employing double-decked bus instead of single-decked bus for KMB 73K and increasing the frequency for both KMB 73K and KMB 79K during morning and evening peak period with the corresponding occupancy as summarised in **Table 4.9.12**. The proposed fleet size associated with the bus enhancement proposal are summarised in **Table 4.9.13**.

Table 4.9.12 Proposed Bus Enhancement and associated occupancy in Year 2031

Bus Route	Peak Period	Direction	Existing Frequency during peak hour (mins)	Proposed Frequency during peak hour (mins)	Proposed No. of Bus Trips during peak hour (bus trips/hr)	Total Capacity* (pax/hr)	2031 Design Peak Franchised Bus Passenger Demand (pax/hr)	Occupancy
KMB 73K	AM	Sheung Shui	15 - 30	4 - 6	12	1,440	1040	72%
		Man Kam To	10 - 20				1020	71%
	PM	Sheung Shui	20 - 25				963	67%
		Man Kam To	20 - 25				1042	72%
KMB 79K	AM	Sheung Shui	15 - 30	6 - 9	8	960	616	64%
		Ta Kwu Ling	30				548	57%
	PM	Sheung Shui	25 - 30				556	58%
		Ta Kwu Ling	25 - 30				660	69%

Note:

* Assumed Bus Capacity is 120 passengers per vehicle

Table 4.9.13 Proposed Fleet Size associated with the Bus Enhancement Proposal

Bus Route	(A) Proposed Average Frequency during peak hour (mins)	(B) Estimated One-way Traveling Distance under the Proposed Service Extension (km)	(C) Observed Average speed (km/h)	(D) (=B)/(C)) Estimated One-way Journey Time (mins)	(E) (=D)/(A) x 2) Proposed Fleet Size
KMB 73K	$(4+6) / 2 = 5$	8	16	30	12
KMB 79K	$(6+9) / 2 = 7.5$	18	13.5	80	22

- 4.9.15 With the proposed bus enhancement of KMB 73K and KMB 79K, it is anticipated that there would be sufficient spare capacities to accommodate the additional passenger demand induced by the Indicative Scheme during morning and evening peak period in year 2031. The associated bus trips have also been distributed into the road network and incorporated into the traffic forecast.
- 4.9.16 Besides, it is proposed to provide transport interchange with 1 no. bus drop-off bay, 4 nos. bus pick-up bays and 12 nos. stacking bays for the proposed existing bus service enhancement underneath the R&D Centre 2, together with taxi stand to accommodate 5 nos. NT taxi and 5 nos. urban taxi and in accordance with TPDM requirement. as illustrated in **Figure 4.17**.
- 4.9.17 Charging-enabling facilities for each bus bay (2.5m(L) x 1.5m(W) x 2.6m(H)) and 4 nos. taxi (2 nos. NT taxi & 2 no. urban taxi, 2.5m(L) x 1.5m(W)) in accordance with EPD requirement, as well as a 237.5m² (47.5m(L) x 5m(W)) integrated structure of staff ancillary facilities for bus operators and passenger facilities such as kiosks and toilets in accordance with TPDM requirement has also been incorporated in the proposed transport interchange.
- 4.9.18 Furthermore, two sets of en-route bus stops would be provided outside the Residential Area and Data Centre in order to enhance the efficiency of the proposed feeder services and long-haul services. It is hence anticipated that the accessibility of the Indicative Scheme is considered acceptable, and the Indicative Scheme would not impose adverse impact to existing PT services.
- 4.9.19 The swept path analysis of 12.8m long bus manoeuvring along the proposed signalized junction of Lin Ma Hang Road / Proposed Access Road is presented from **Figure 3.7** to **Figure 3.9**, while the swept path analysis of 12.8m long bus manoeuvring between the proposed transport interchange and the en-route bus stops is presented in **Figure 4.18**.
- 4.9.20 On the other hand, the swept path analysis of 12.8m long bus manoeuvring along each bus bay and stacking bay is presented from **Figure 4.19** to **Figure 4.23**, while the swept path analysis of 5m long taxi manoeuvring along the taxi stand is presented in **Figure 4.24**.

4.10 Railway Assessment

- 4.10.1 According to the Press Releases dated 6 Nov 2024, from the National Day Golden Week to Chung Yeung Festival in 2024, the weekday patronage for the critical link of East Rail Line (EAL) from 8am to 10am (Tai Wai to Kowloon Tong) and from 5pm to 7pm (Kowloon Tong to Tai Wai) was about 70,100 and 65,600 respectively. [Source: <https://www.info.gov.hk/gia/general/202411/06/P2024110600173.htm?fontSize=1>]
- 4.10.2 From the above statistic and assuming a factor of 1.2 for conservative approach, it could be estimated that the hourly patronage during morning and evening peak would be $70,100 / 2 \times 1.2 = 42,060$ and $65,600 / 2 \times 1.2 = 39,360$ respectively.
- 4.10.3 Similar to franchised buses, it is considered that the usage of EAL is hugely related to planned population and employment within its catchment area, hence the highest growth factor (i.e. +2.62% p.a.) as discussed in Section 4.9.10 and Section

4.9.11 would be applied to the Year 2024 recorded patronage to forecast railway demand in Design Year 2031 for conservative assessment purpose.

4.10.4 The forecasted hourly patronage for the critical link of EAL during morning and evening peak in 2031 would be $42,060 \times (1+2.62\%)^{(2031-2024)} = 50,412$ passengers and $39,360 \times (1+2.62\%)^{(2031-2024)} = 47,176$ passengers respectively.

4.10.5 According to MTR website [Source: https://www.mtr.com.hk/en/corporate/operations/detail_worldclass.html], the existing carrying capacity of EAL during peak period is 62,500 passengers per hour per direction, which is based on 6 persons (standing) per square metre (ppsm). According to Replies to initial and supplementary questions raised by Legislative Council Members in examining the Estimates of Expenditure 2023-24 Reply Serial No. TLB168 [Source: https://www.td.gov.hk/filemanager/en/content_1863/fcq%202023-24%20eng.pdf], the capacity of trains is 2,845 and 2,061 respectively for 6 and 4 ppsm for EAL, which indicates that the carrying capacity under 4 ppsm is 72.4% of that of 6 ppsm, i.e., 45,275. For conservative approach, carrying capacity under 4 ppsm would be adopted, and EAL would be overloaded already regardless of the population intake of the Indicative Scheme, hence enhancement of train frequency would be required.

4.10.6 According to the aforementioned Reply Serial No. TLB168, when train frequency is maximised, the maximum carrying capacity of EAL would increase to 82,500 for 6 ppsm, which is equivalent to $82,500 \times 72.4\% = 59,765$ for 4 ppsm, and the corresponding usage during morning and evening peak hour in 2031 would be $50,412 / 59,765 = 85\%$ and $47,176 / 59,765 = 79\%$, which indicates that there would still be ample capacity of $1 - 85\% = 15\%$ and $1 - 79\% = 21\%$ respectively.

4.10.7 As derived in **Table 4.9.5**, the anticipated resident passenger generated from the Indicative Scheme and worker passenger attracted to Indicative Scheme taking EAL would be 778 passengers towards Admiralty bound and 683 passengers towards Sheung Shui bound per hour respectively, which is equivalent to about 1.3% ($778 / 59,765$) and 1.1% ($683 / 59,765$) of maximum carrying capacity only. With the identified ample capacity of EAL 15% and 21% during morning and evening peak hour, it can be concluded that the MTR passenger demand induced by the Indicative Scheme could be properly catered by EAL under maximum carrying capacity and thus no adverse railway impact would be induced by the Indicative Scheme. The actual frequency enhancement may not be necessary to reach the maximum carrying capacity, subjected to the future operational need.

5 CONCLUSION

5.1 Summary

- 5.1.1 The Application Site is located in Zone with major part in Agriculture (“AGR”), and minor parts in Green Belt (“GB”), Government, Institution or Community (“G/IC”) at Various Lots in D.D.82 & D.D.86, Man Kam To, New Territories.
- 5.1.2 The Applicant proposes amendments to rezone the Application Site with a sizeable site area of about 125,863m² (Development site area of about 102,461m²) into an Innovation and Technology Hub with Ancillary Facilities (the “Indicative Scheme”), subject to a non-domestic gross floor area (GFA) of 365,180m², which consists of R&D Centre with 268,780m² GFA and Data Centre with 86,400m² GFA to nurture the development of I&T industry, as well as a Commercial Centre with 9,276m² to support the daily needs of the working and living population. A kindergarten of 724m² will be provided on the ground floor of Ancillary Dormitories. In addition, there will be a domestic GFA of 170,400m², which consists of Private Residential Blocks providing a total of 2,320 units together with a 3,500m² Clubhouse, and Ancillary Dormitories with 63,900m² which provide 1,392 units for the working population of R&D Centre.
- 5.1.3 A Traffic Impact Assessment (TIA) study was carried out to evaluate the likely traffic impact associated with the Indicative Scheme, in support of the S12A planning application for proposed amendment of plan.
- 5.1.4 This TIA is to examine the impact of traffic induced by the Indicative Scheme on the existing and planned road networks, in particular with respect to the performances of the affected junctions in the vicinity; and present the findings on related traffic and transport issues. Any deficiency would be identified, and improvement proposal would be recommended as necessary to resolve any foreseeable problem from the deficiencies.
- 5.1.5 The proposed provision of internal transport facilities for the subject development is in full compliance with the HKPSG and TD Circular No. 6/2012 requirements, as well as with reference to project with similar use. The proposed internal transport facilities will be provided on ground floor and basement parking floors.
- 5.1.6 In order to assess the future traffic impacts associated with the Proposed Development in year 2031, two levels of transport models are adopted, with the Strategic Transport Model (STM) as the upper tier and the Local Area Traffic Model (LATM) as the lower tier. The STM is a link-based transport model which produces transport demand forecasts at strategic and inter-district levels, while the LATM is a junction-based assignment model which stimulates the local area traffic demand at intra-district level based on the latest available 2019-based Base District Traffic Model (BDTM). The LATM has been further validated to latest traffic condition based on the 2023 observed peak hour traffic on identified key junctions and road links, taking into account the latest traffic aids, junction layouts and method of control in the study area.
- 5.1.7 Traffic impact assessment scenarios were set up to evaluate the associated traffic impact likely to be induced by the Indicative Scheme. **Scenario 1** is the Reference Scenario (without the Indicative Scheme) in Year 2031. **Scenario 2** is the Design Scenario (with the Indicative Scheme) in 2031.

- 5.1.8 The junction assessment results revealed that all identified key junctions would operate within capacity with the Indicative Scheme in Year 2031, except J1 – Lin Ma Hang Road / Man Kam To Road, J2 – Lin Ma Hang Road/ Ping Che Road, J8 – Sha Tau Kok Road/ Sui Wan Road, J13 – Po Shek Wu Road/ Po Wan Road, and J23 – San Wan Road / Fanling Station Road.
- 5.1.9 With the proposed junction improvement at J1, J2, J8, J13 and J23, it is anticipated that the implication to the road network with the Indicative Scheme would be minimal.
- 5.1.10 The road link assessment results revealed that all identified key road links assessed will be performing satisfactorily with spare capacity in both Reference and Design scenarios in Year 2031.
- 5.1.11 The Applicant proposes to enhance the existing bus services of KMB 73K and KMB 79K by employing double-decked bus instead of single-decked bus for KMB 73K and increasing the frequency for both KMB 73K and KMB 79K during morning and evening peak period, together with transport interchange with 1 no. bus drop-off bay, 4 nos. bus pick-up bays and 12 nos. stacking bays as well as 1 no. taxi stand underneath the R&D Centre 2, and two sets of en-route bus stops outside Residential Area and Data Centre in order to enhance the efficiency of the proposed existing bus service enhancement. It is hence anticipated that the accessibility of the Indicative Scheme is considered acceptable, and the Indicative Scheme would not impose adverse impact to existing PT services.

5.2 Conclusion

- 5.2.1 It could be concluded that the Indicative Scheme will not impose adverse traffic impact on the surrounding road network, and thus is feasible from the traffic engineering point of view.

Figures

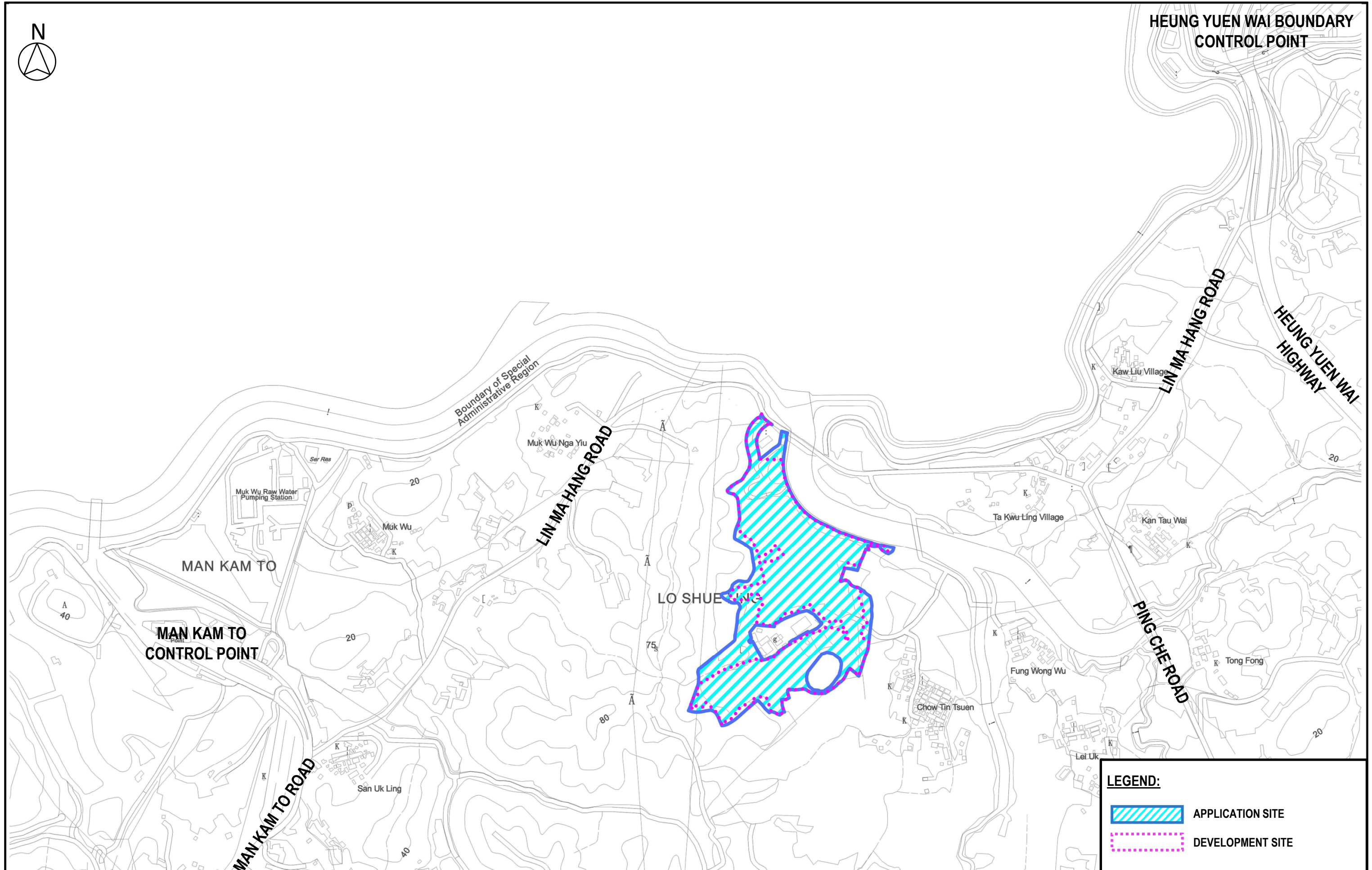
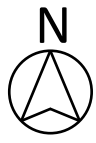

HEUNG YUEN WAI BOUNDARY CONTROL POINT

MAN KAM TO CONTROL POINT

LEGEND:

-  APPLICATION SITE
-  DEVELOPMENT SITE

Job Title **APPLICATION FOR AMENDMENT OF PLAN UNDER SECTION 12A OF THE TOWN PLANNING ORDINANCE (CAP. 131) FOR PROPOSED INNOVATION AND TECHNOLOGY HUB AT VARIOUS LOTS IN D.D. 82 AND D.D. 86 AND ADJOINING GOVERNMENT LAND, MAN KAM TO, NEW TERRITORIES**

FIGURE 1.1

Date	Scale	Drawing Title
FEB 25	NTS	LOCATION OF APPLICATION SITE
Drawn	Job No.	
CKTY	287082-02	

LOCATION OF APPLICATION SITE



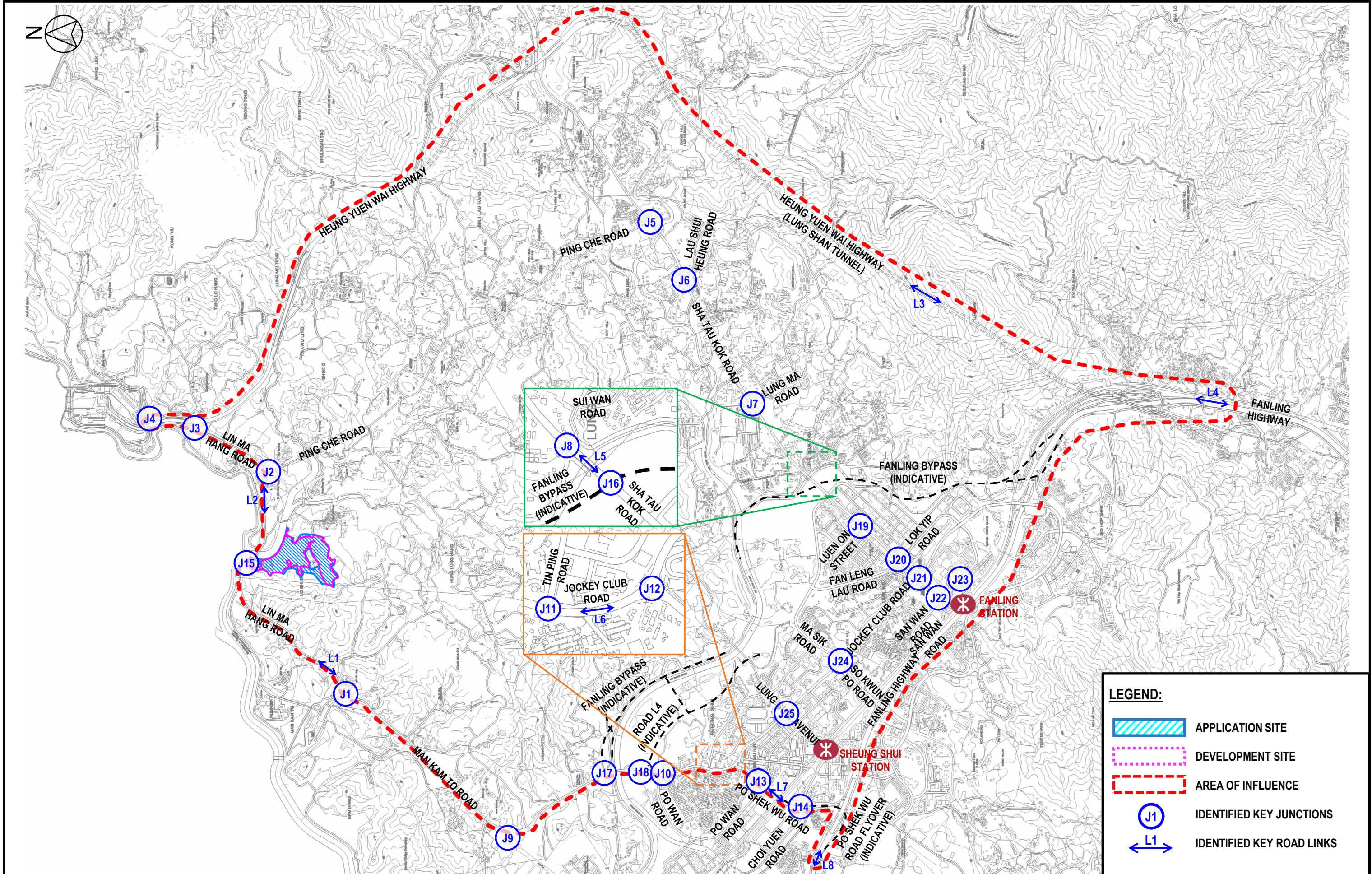

Job Title APPLICATION FOR AMENDMENT OF PLAN UNDER SECTION 12A OF THE TOWN PLANNING ORDINANCE (CAP. 131) FOR PROPOSED INNOVATION AND TECHNOLOGY HUB AT VARIOUS LOTS IN D.D. 82 AND D.D. 86 AND ADJOINING GOVERNMENT LAND, MAN KAM TO, NEW TERRITORIES

FIGURE 2.1

Date	Scale	Drawing Title
FEB 25	NTS	
Drawn	Job No.	
CKTY	287082-02	

LOCATION OF IDENTIFIED KEY JUNCTIONS AND ROAD LINKS IN THE VICINITY OF APPLICATION SITE – OVERVIEW



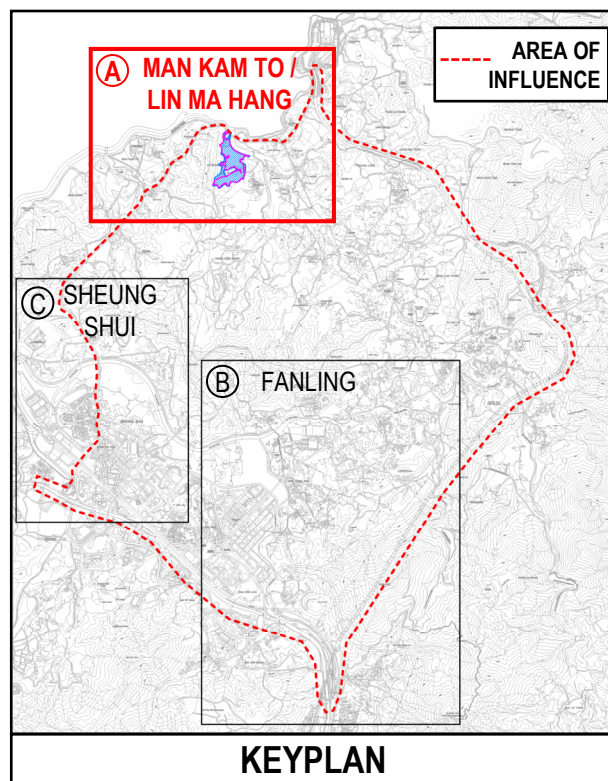



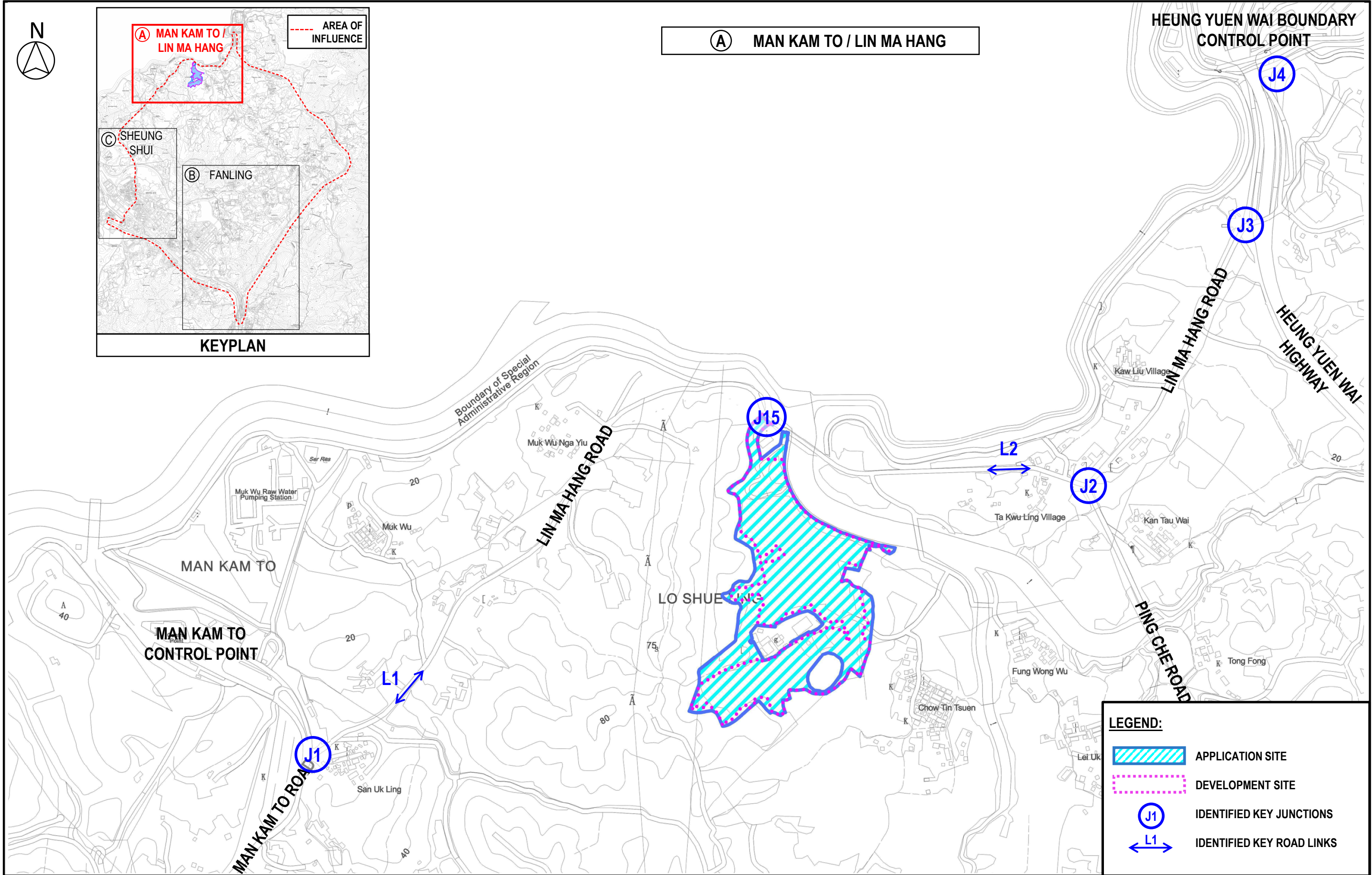

① MAN KAM TO / LIN MA HANG



LEGEND:

-  APPLICATION SITE
-  DEVELOPMENT SITE
-  IDENTIFIED KEY JUNCTIONS
-  IDENTIFIED KEY ROAD LINKS

Job Title: APPLICATION FOR AMENDMENT OF PLAN UNDER SECTION 12A OF THE TOWN PLANNING ORDINANCE (CAP. 131) FOR PROPOSED INNOVATION AND TECHNOLOGY HUB AT VARIOUS LOTS IN D.D. 82 AND D.D. 86 AND ADJOINING GOVERNMENT LAND, MAN KAM TO, NEW TERRITORIES

FIGURE 2.2

Date	Scale	Drawing Title
FEB 25	NTS	
Drawn	Job No.	
CKTY	287082-02	

LOCATION OF IDENTIFIED KEY JUNCTIONS AND ROAD LINKS IN THE VICINITY OF APPLICATION SITE – MAN KAM TO / LIN MA HANG AREA



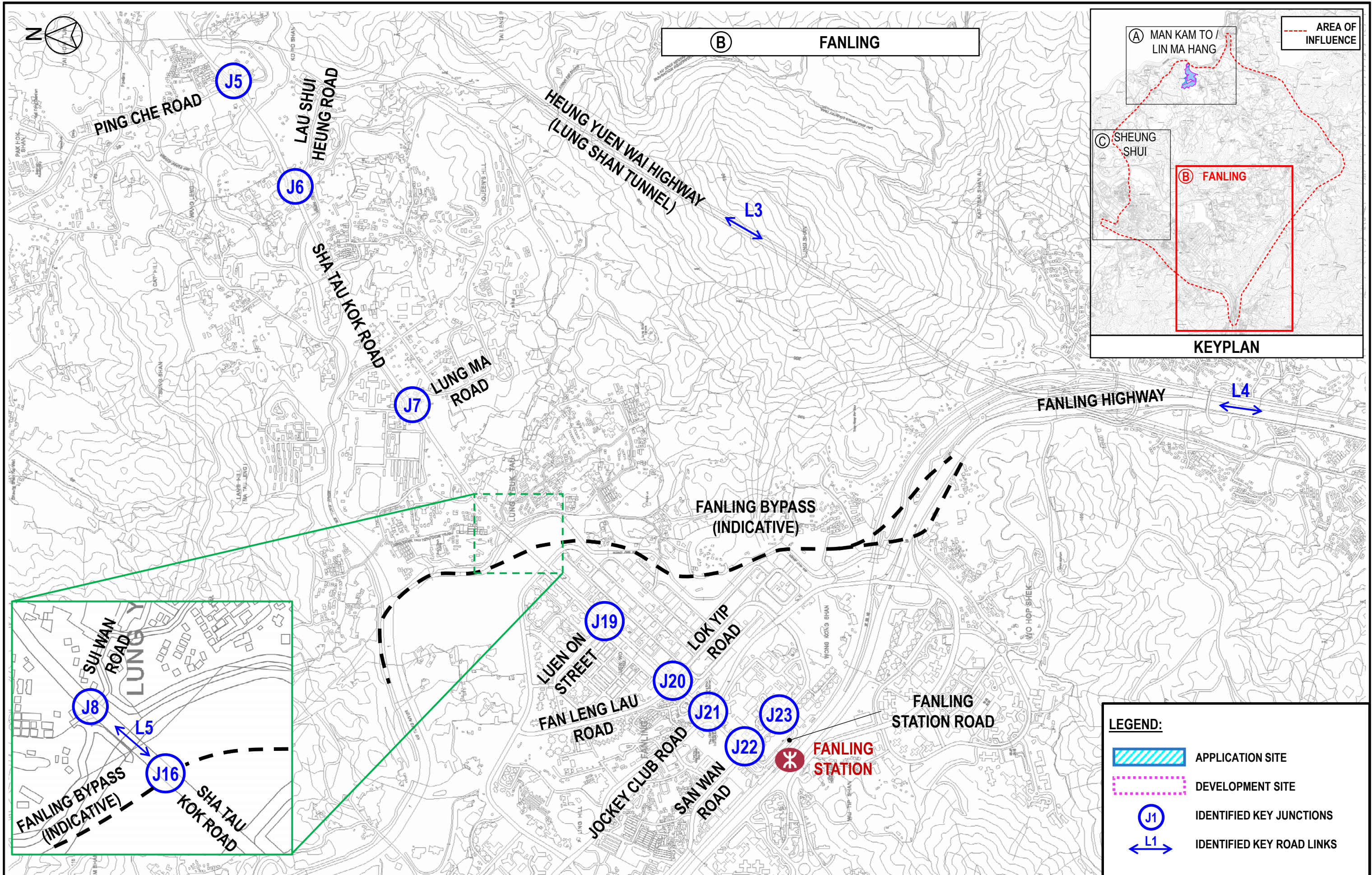

Job Title APPLICATION FOR AMENDMENT OF PLAN UNDER SECTION 12A OF THE TOWN PLANNING ORDINANCE (CAP. 131) FOR PROPOSED INNOVATION AND TECHNOLOGY HUB AT VARIOUS LOTS IN D.D. 82 AND D.D. 86 AND ADJOINING GOVERNMENT LAND, MAN KAM TO, NEW TERRITORIES

FIGURE 2.3

Date	Scale	Drawing Title
FEB 25	NTS	
Drawn	Job No.	
CKTY	287082-02	

LOCATION OF IDENTIFIED KEY JUNCTIONS AND ROAD LINKS IN THE VICINITY OF APPLICATION SITE – FANLING AREA



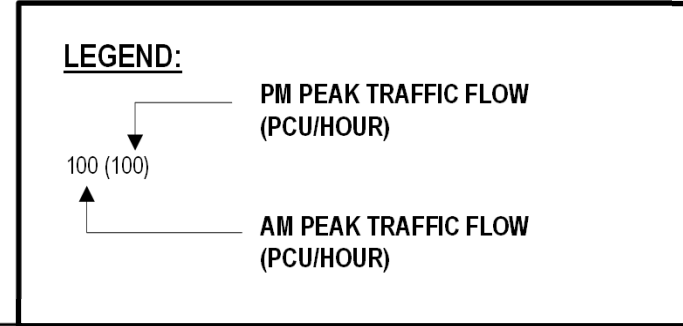
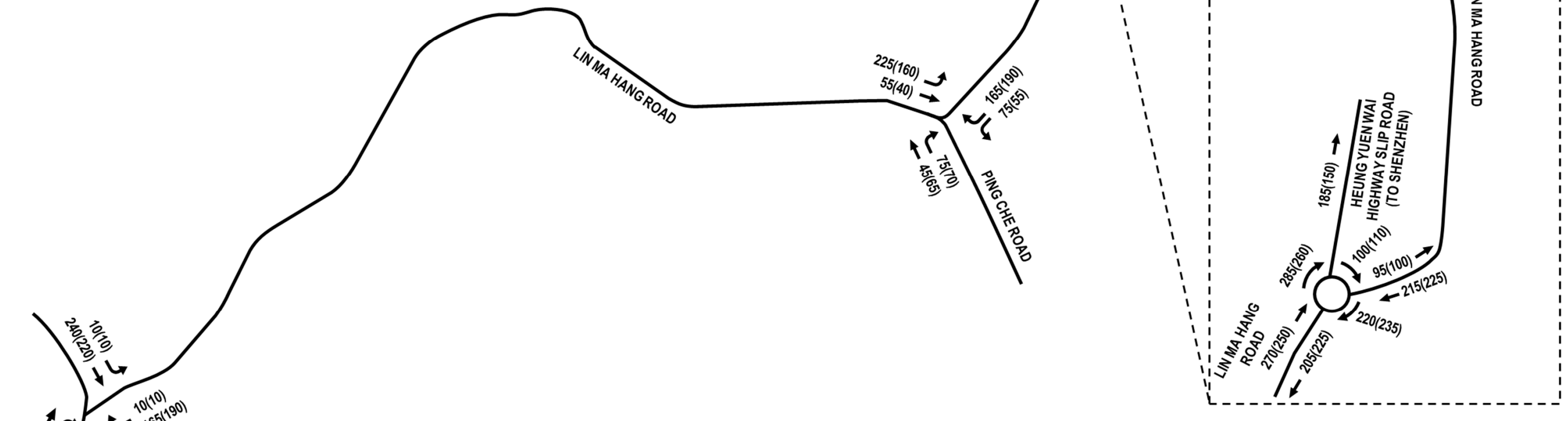
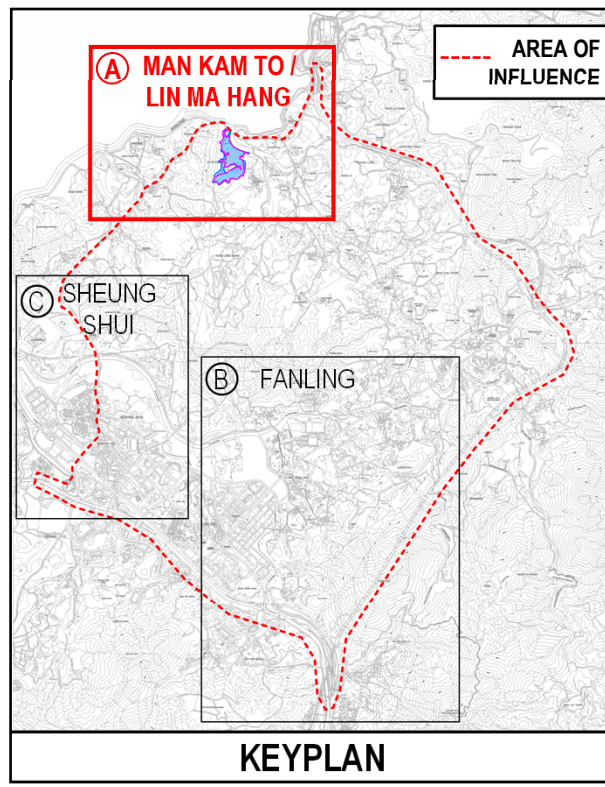

Job Title: APPLICATION FOR AMENDMENT OF PLAN UNDER SECTION 12A OF THE TOWN PLANNING ORDINANCE (CAP. 131) FOR PROPOSED INNOVATION AND TECHNOLOGY HUB AT VARIOUS LOTS IN D.D. 82 AND D.D. 86 AND ADJOINING GOVERNMENT LAND, MAN KAM TO, NEW TERRITORIES

FIGURE 2.5

Date: FEB 25
 Scale: NTS
 Drawn: CKTY
 Job No.: 287082-02

YEAR 2023 EXISTING TRAFFIC FLOW – MAN KAM TO / LIN MA HANG AREA



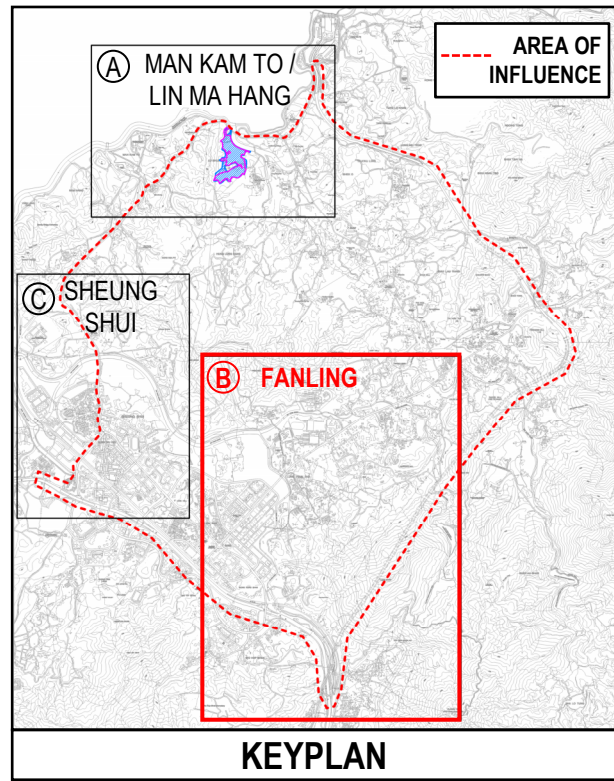
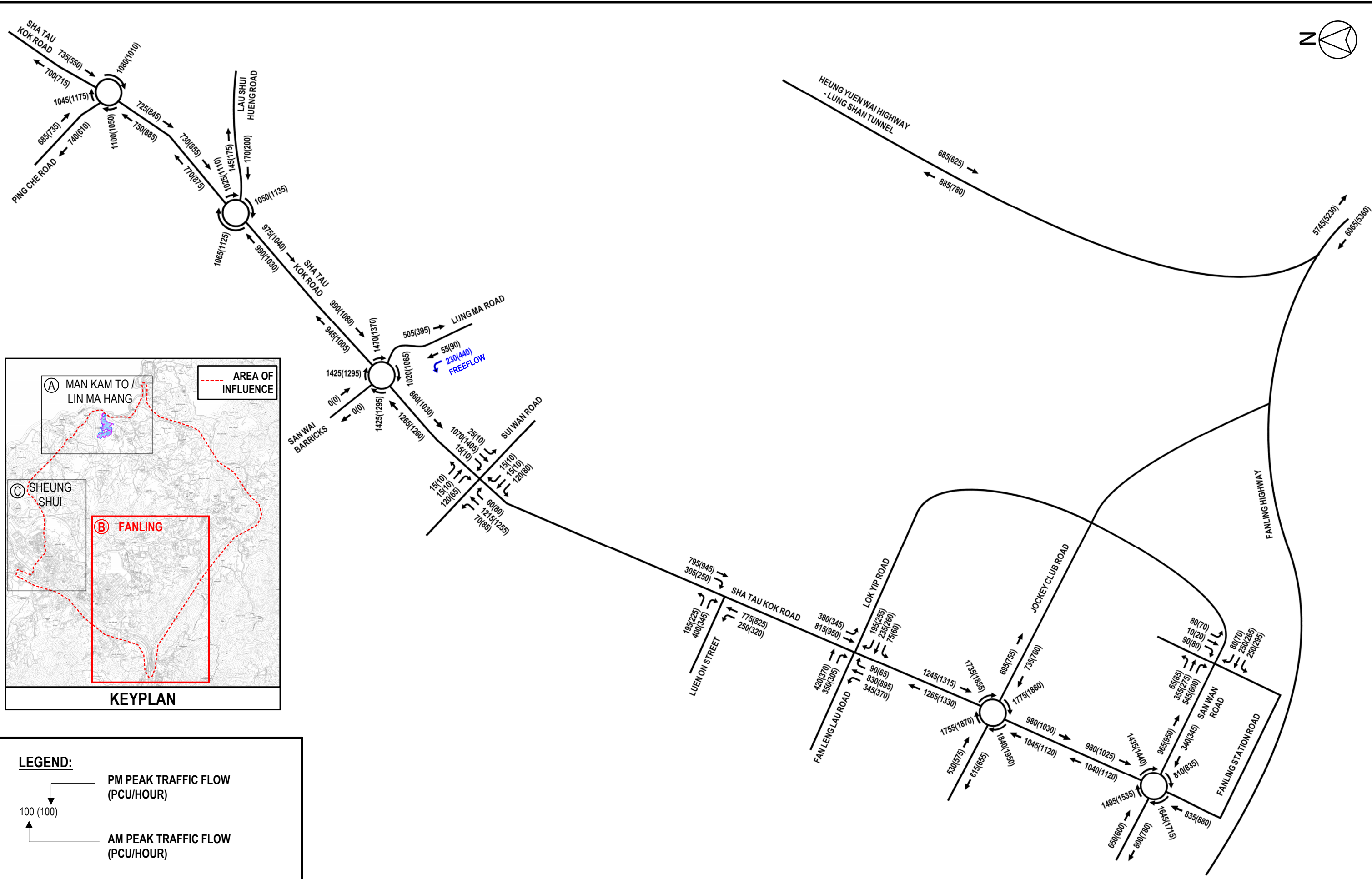

LEGEND:

PM PEAK TRAFFIC FLOW (PCU/HOUR)
 AM PEAK TRAFFIC FLOW (PCU/HOUR)

Job Title APPLICATION FOR AMENDMENT OF PLAN SECTION 12A OF THE TOWN PLANNING ORDINANCE (CAP. 131) FOR PROPOSED INNOVATION AND TECHNOLOGY HUB AT VARIOUS LOTS IN D.D. 82 AND D.D. 86 AND ADJOINING GOVERNMENT LAND, MAN KAM TO, NEW TERRITORIES

FIGURE 2.6

Date	Scale	Drawing Title
FEB 25	NTS	YEAR 2023 EXISTING TRAFFIC FLOW – FANLING AREA
Drawn	Job No.	
CKTY	287082-02	

YEAR 2023 EXISTING TRAFFIC FLOW – FANLING AREA



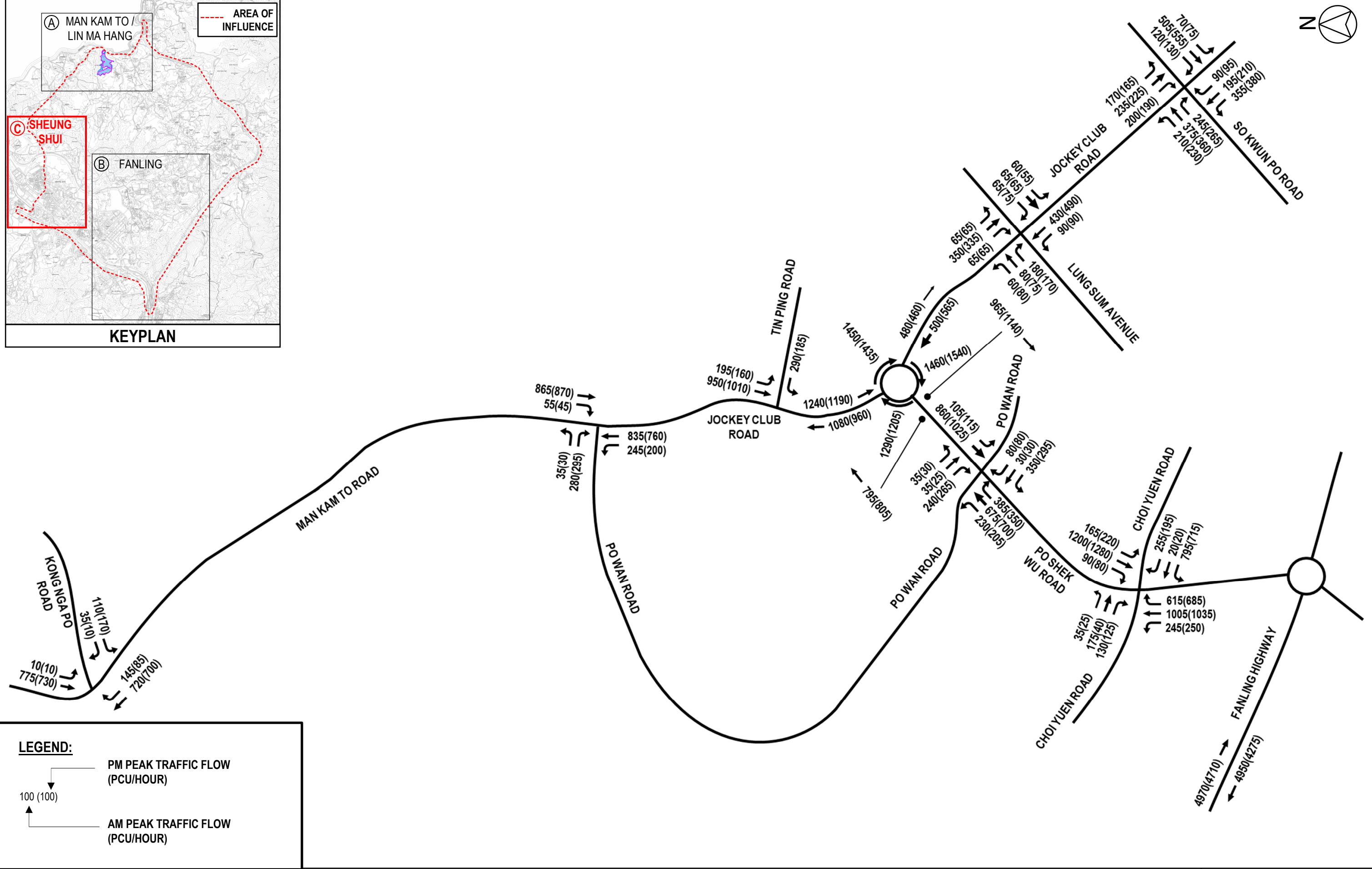
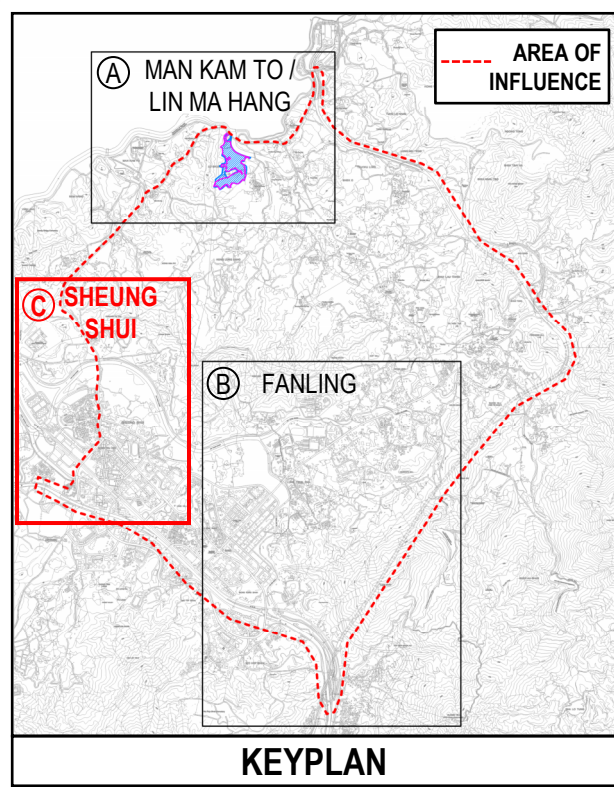

Job Title: APPLICATION FOR AMENDMENT OF PLAN UNDER SECTION 12A OF THE TOWN PLANNING ORDINANCE (CAP. 131) FOR PROPOSED INNOVATION AND TECHNOLOGY HUB AT VARIOUS LOTS IN D.D. 82 AND D.D. 86 AND ADJOINING GOVERNMENT LAND, MAN KAM TO, NEW TERRITORIES

FIGURE 2.7

Date	Scale	Drawing Title
FEB 25	NTS	YEAR 2023 EXISTING TRAFFIC FLOW – SHEUNG SHUI AREA
Drawn	Job No.	
CKTY	287082-02	





HEUNG YUEN WAI BOUNDARY CONTROL POINT

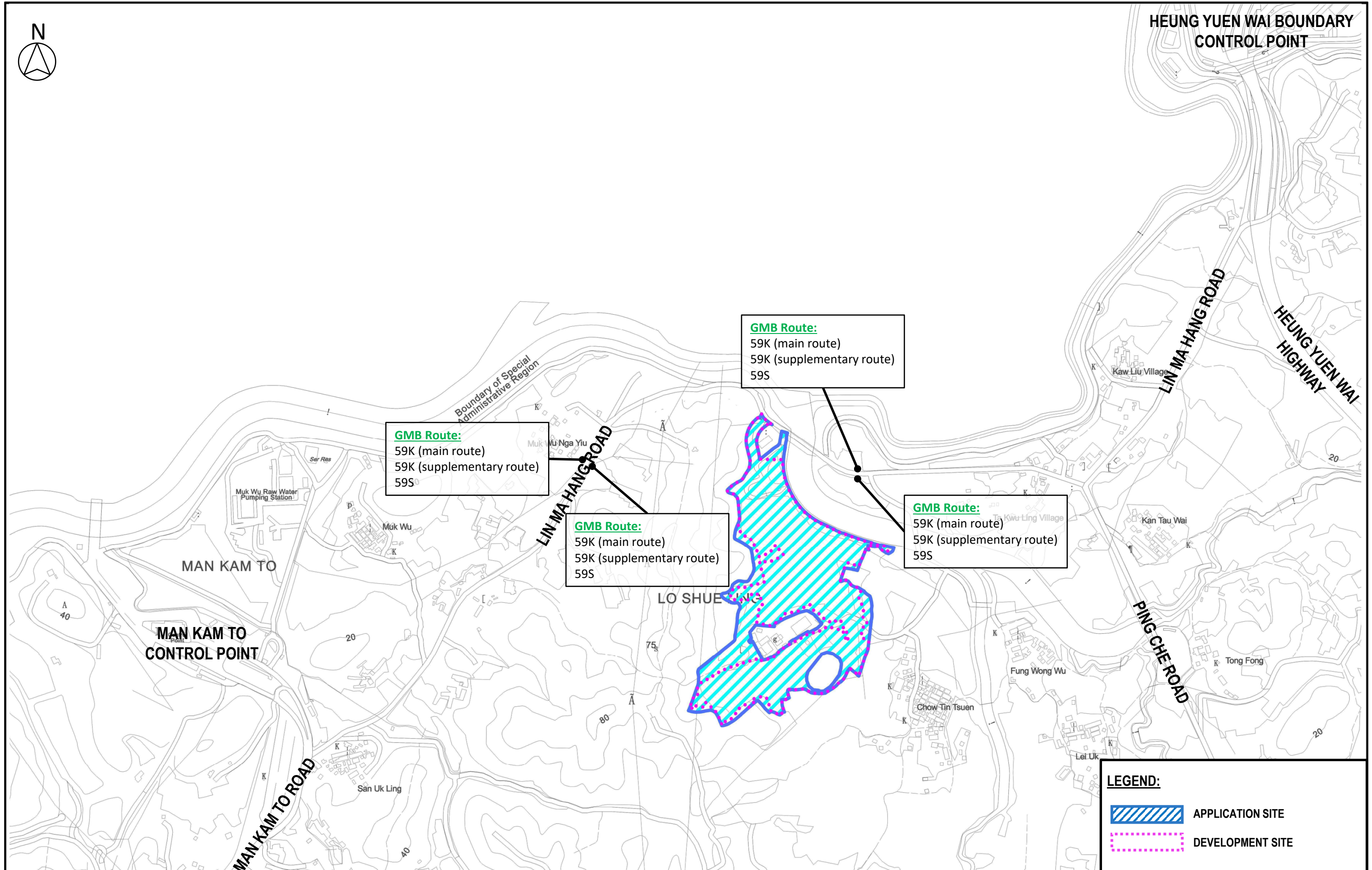

GMB Route:
59K (main route)
59K (supplementary route)
59S

GMB Route:
59K (main route)
59K (supplementary route)
59S

GMB Route:
59K (main route)
59K (supplementary route)
59S

GMB Route:
59K (main route)
59K (supplementary route)
59S

LEGEND:

-  APPLICATION SITE
-  DEVELOPMENT SITE

Job Title **APPLICATION FOR AMENDMENT OF PLAN UNDER SECTION 12A OF THE TOWN PLANNING ORDINANCE (CAP. 131) FOR PROPOSED INNOVATION AND TECHNOLOGY HUB AT VARIOUS LOTS IN D.D. 82 AND D.D. 86 AND ADJOINING GOVERNMENT LAND, MAN KAM TO, NEW TERRITORIES**

FIGURE 2.8

Date **FEB 25** Scale **NTS**

Drawing Title **PUBLIC TRANSPORT FACILITIES IN THE VICINITY OF APPLICATION SITE**

Drawn **CKTY** Job No. **287082-02**



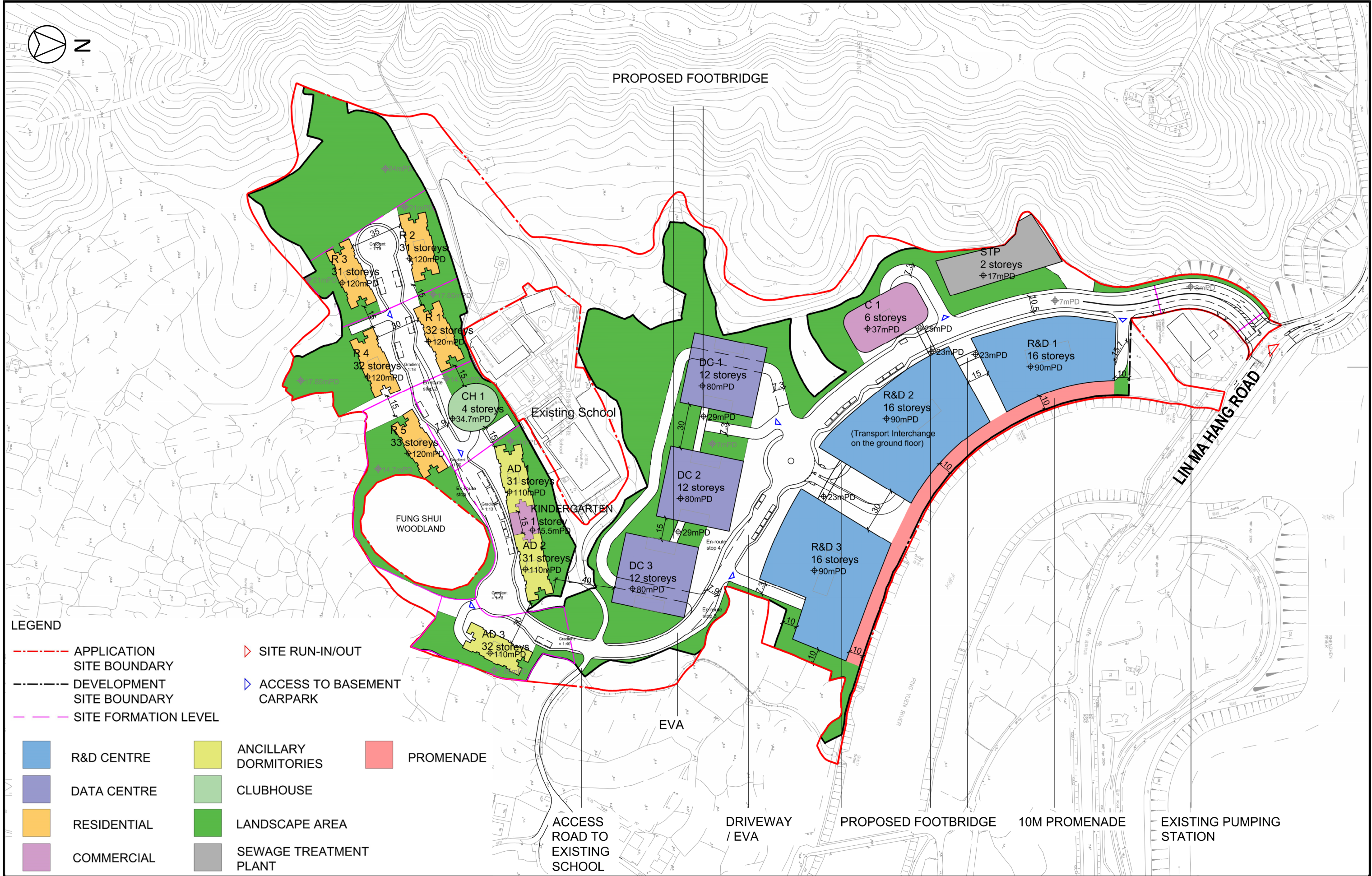

LEGEND

	APPLICATION SITE BOUNDARY		SITE RUN-IN/OUT
	DEVELOPMENT SITE BOUNDARY		ACCESS TO BASEMENT CARPARK
	SITE FORMATION LEVEL		
	R&D CENTRE		ANCILLARY DORMITORIES
	DATA CENTRE		CLUBHOUSE
	RESIDENTIAL		LANDSCAPE AREA
	COMMERCIAL		SEWAGE TREATMENT PLANT
			PROMENADE

Job Title **APPLICATION FOR AMENDMENT OF PLAN UNDER SECTION 12A OF THE TOWN PLANNING ORDINANCE (CAP. 131) FOR PROPOSED INNOVATION AND TECHNOLOGY HUB AT VARIOUS LOTS IN D.D. 82 AND D.D. 86 AND ADJOINING GOVERNMENT LAND, MAN KAM TO, NEW TERRITORIES**

FIGURE 3.1

Date	Scale	Drawing Title
FEB 25	NTS	MASTER LAYOUT PLAN OF INDICATIVE SCHEME
Drawn	Job No.	
CKTY	287082-02	



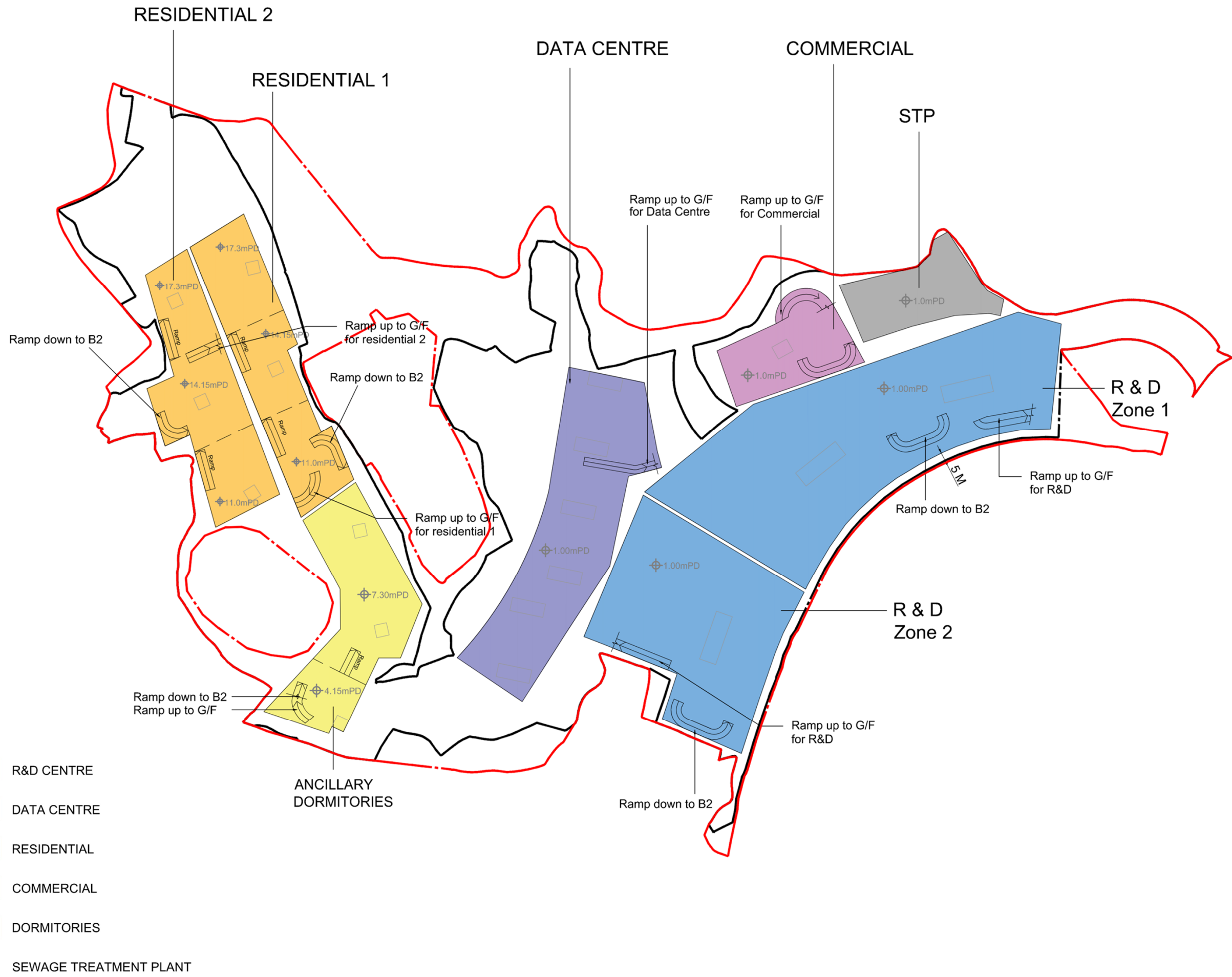
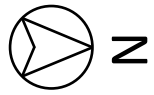

- LEGEND**
- - - APPLICATION SITE BOUNDARY
 - - - DEVELOPMENT SITE BOUNDARY
 - R&D CENTRE
 - DATA CENTRE
 - RESIDENTIAL
 - COMMERCIAL
 - DORMITORIES
 - SEWAGE TREATMENT PLANT

Job Title: **APPLICATION FOR AMENDMENT OF PLAN UNDER SECTION 12A OF THE TOWN PLANNING ORDINANCE (CAP. 131) FOR PROPOSED INNOVATION AND TECHNOLOGY HUB AT VARIOUS LOTS IN D.D. 82 AND D.D. 86 AND ADJOINING GOVERNMENT LAND, MAN KAM TO, NEW TERRITORIES**

FIGURE 3.2

Date	Scale
FEB 25	NTS
Drawn	Job No.
CKTY	287082-02

B1 BASEMENT LEVEL PLAN OF INDICATIVE SCHEME



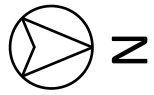

RESIDENTIAL 2

RESIDENTIAL 1

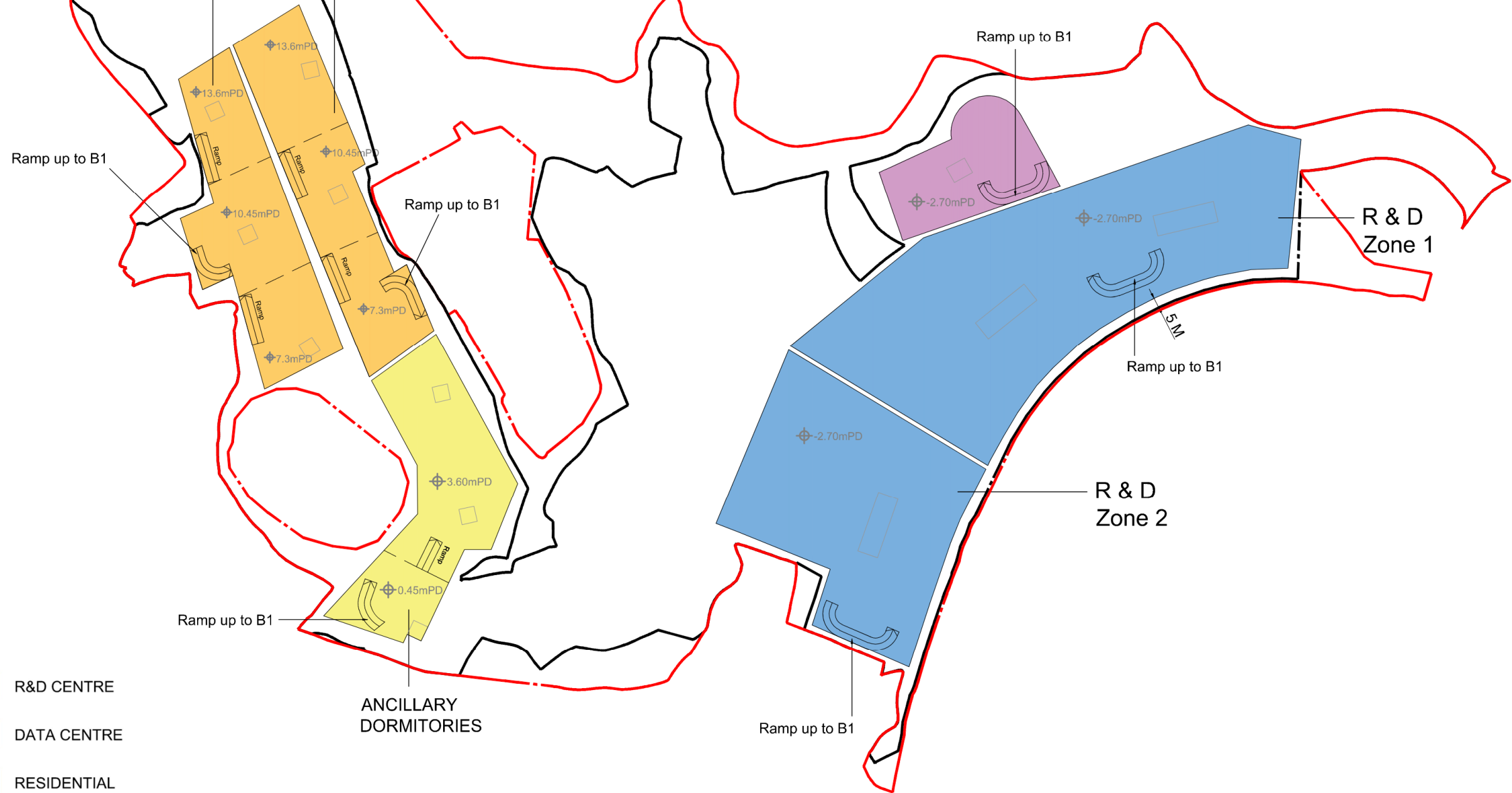

LEGEND

- APPLICATION SITE BOUNDARY
- DEVELOPMENT SITE BOUNDARY
- R&D CENTRE
- DATA CENTRE
- RESIDENTIAL
- COMMERCIAL
- DORMITORIES
- SEWAGE TREATMENT PLANT

Job Title **APPLICATION FOR AMENDMENT OF PLAN UNDER SECTION 12A OF THE TOWN PLANNING ORDINANCE (CAP. 131) FOR PROPOSED INNOVATION AND TECHNOLOGY HUB AT VARIOUS LOTS IN D.D. 82 AND D.D. 86 AND ADJOINING GOVERNMENT LAND, MAN KAM TO, NEW TERRITORIES**

FIGURE 3.3





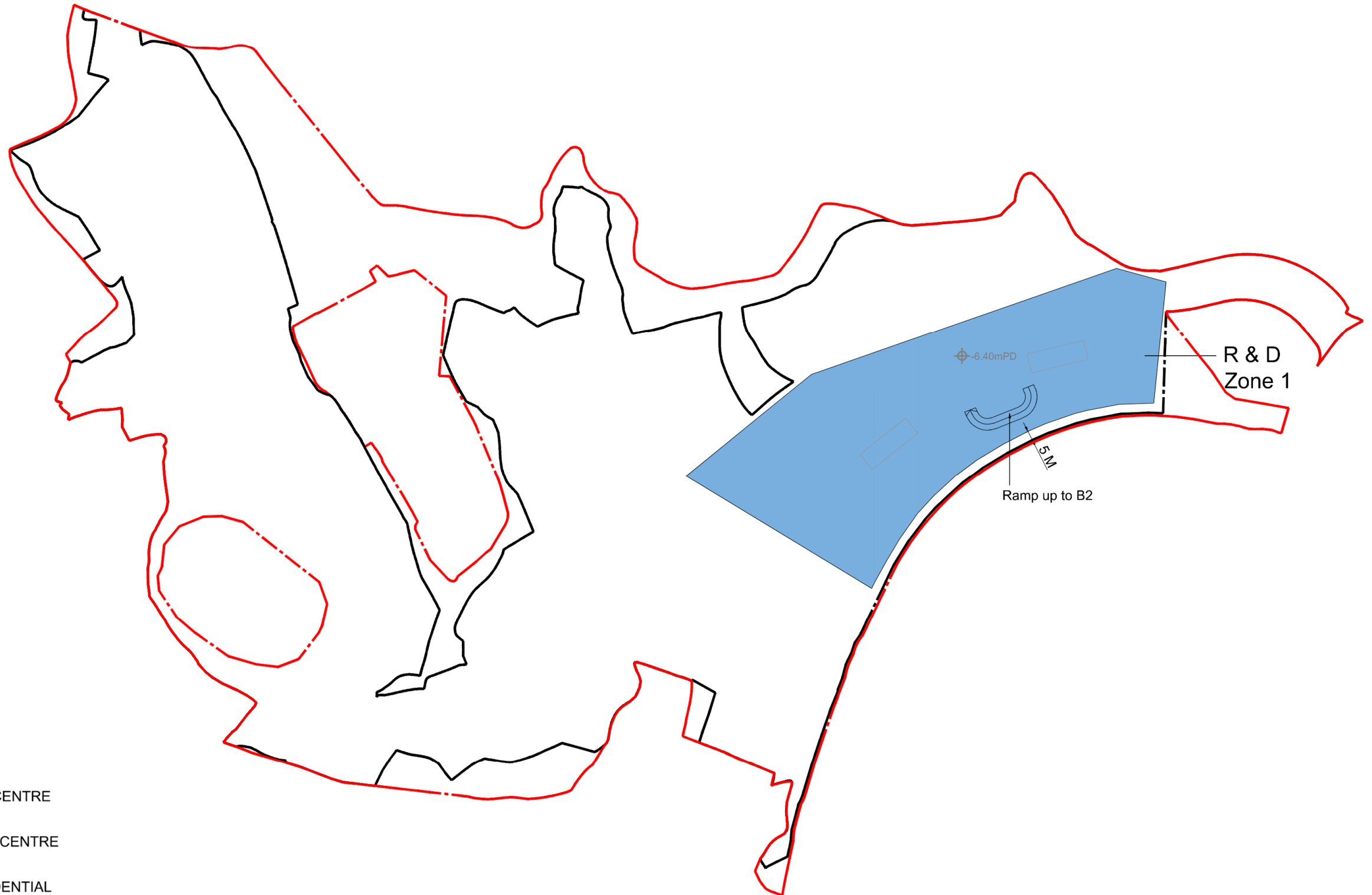
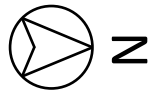

Date **FEB 25**
 Scale **NTS**
 Drawn **CKTY**
 Job No. **287082-02**

B2 BASEMENT LEVEL PLAN OF INDICATIVE SCHEME

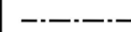



LEGEND

-  APPLICATION SITE BOUNDARY
-  DEVELOPMENT SITE BOUNDARY
-  R&D CENTRE
-  DATA CENTRE
-  RESIDENTIAL
-  COMMERCIAL
-  DORMITORIES
-  SEWAGE TREATMENT PLANT

Job Title APPLICATION FOR AMENDMENT OF PLAN UNDER SECTION 12A OF THE TOWN PLANNING ORDINANCE (CAP. 131) FOR PROPOSED INNOVATION AND TECHNOLOGY HUB AT VARIOUS LOTS IN D.D. 82 AND D.D. 86 AND ADJOINING GOVERNMENT LAND, MAN KAM TO, NEW TERRITORIES

FIGURE 3.4

Date	Scale
FEB 25	NTS
Drawn	Job No.
CKTY	287082-02

Drawing Title
B3 BASEMENT LEVEL PLAN OF INDICATIVE SCHEME



LEGEND

- R&D CENTRE
- DATA CENTRE
- ANCILLARY DORMITORY
- RESIDENTIAL
- COMMERCIAL
- CLUBHOUSE
- SEWAGE TREATMENT PLANT
- TRANSPORT INTERCHANGE

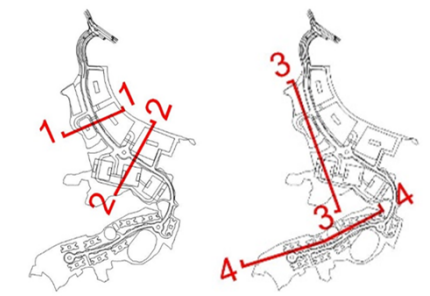

Key Plan

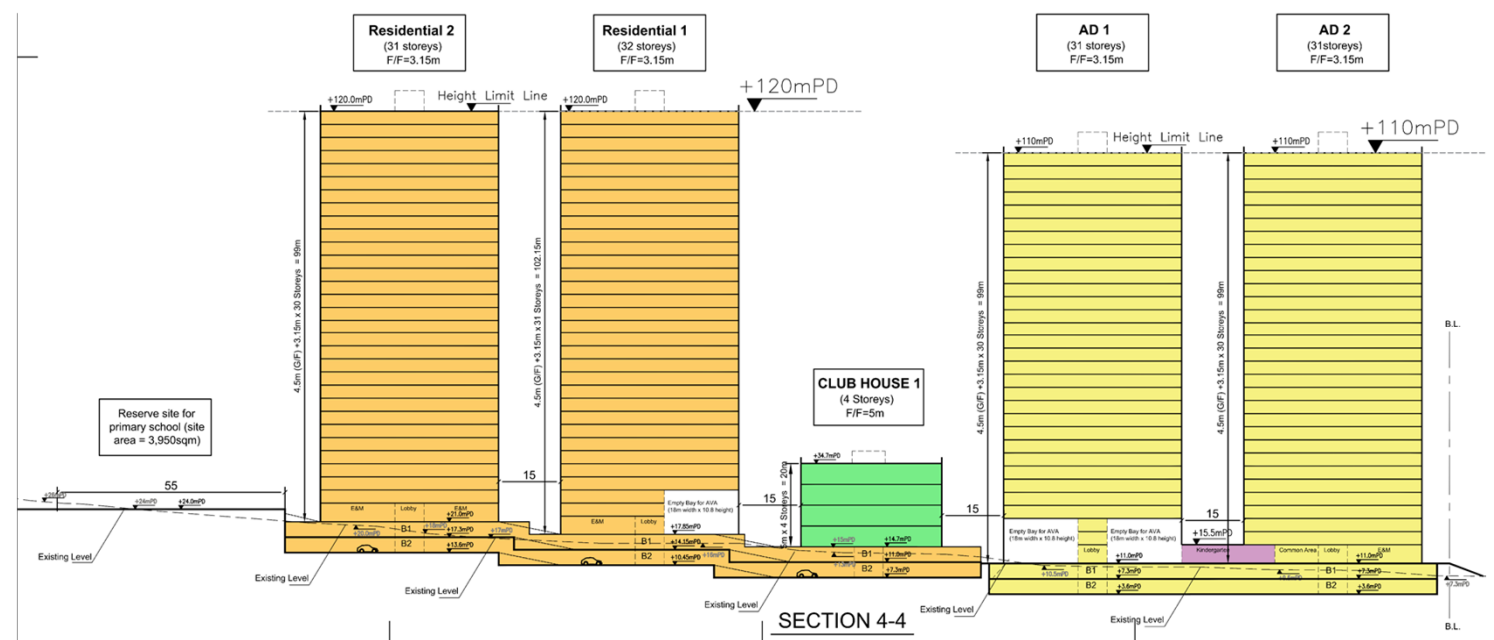
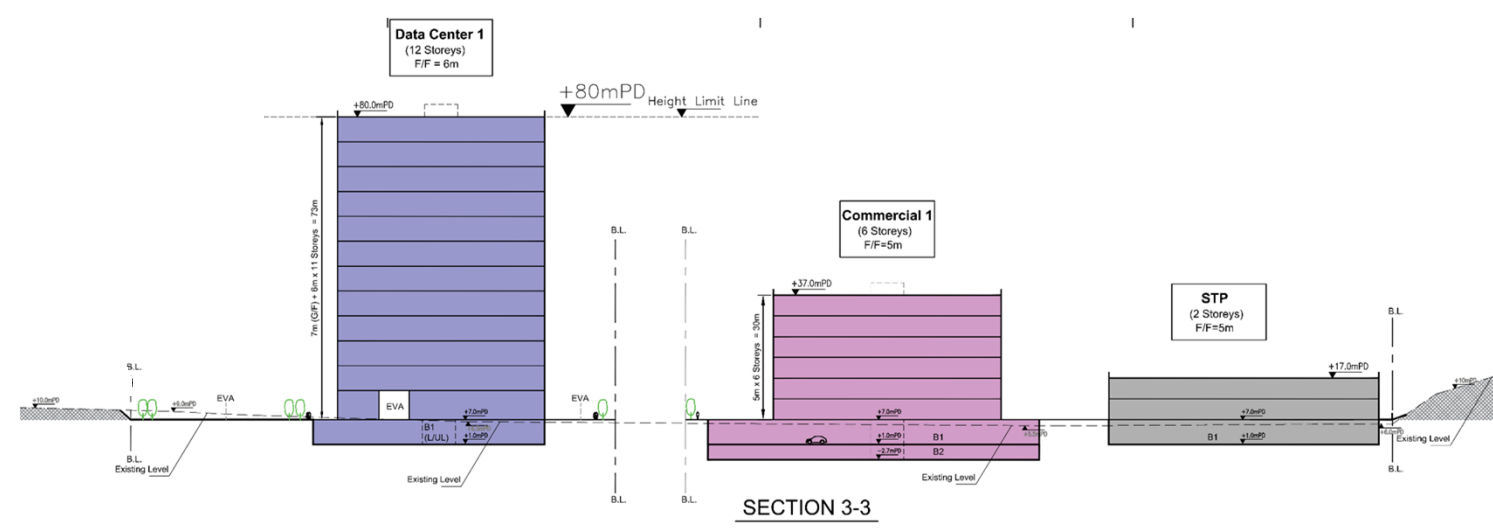
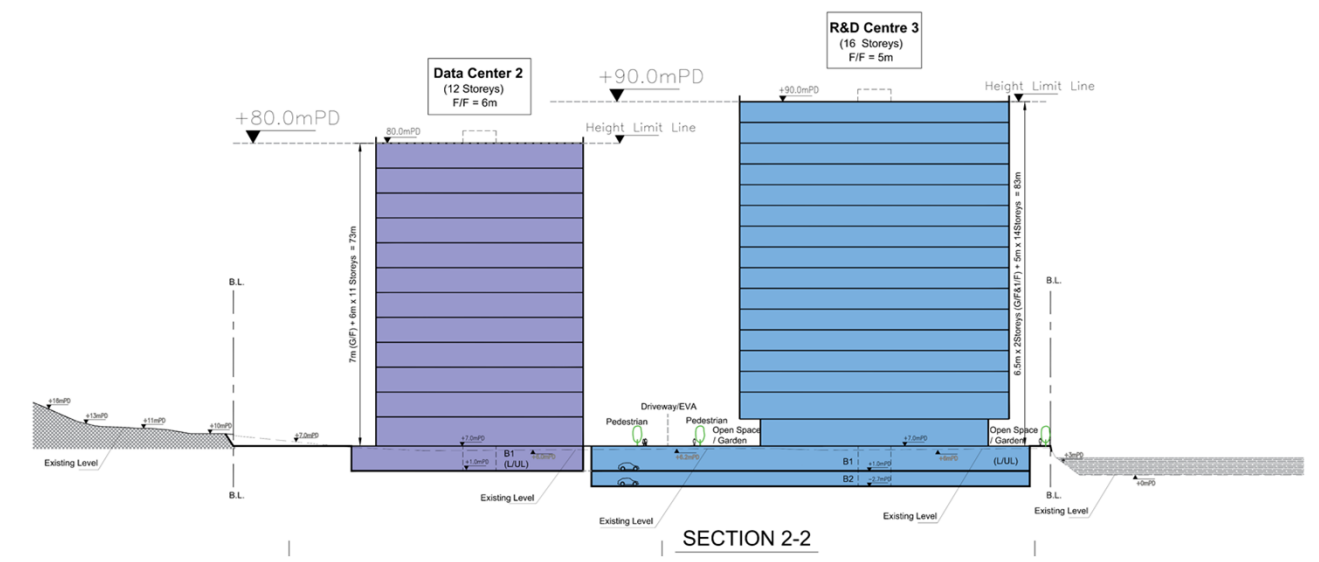
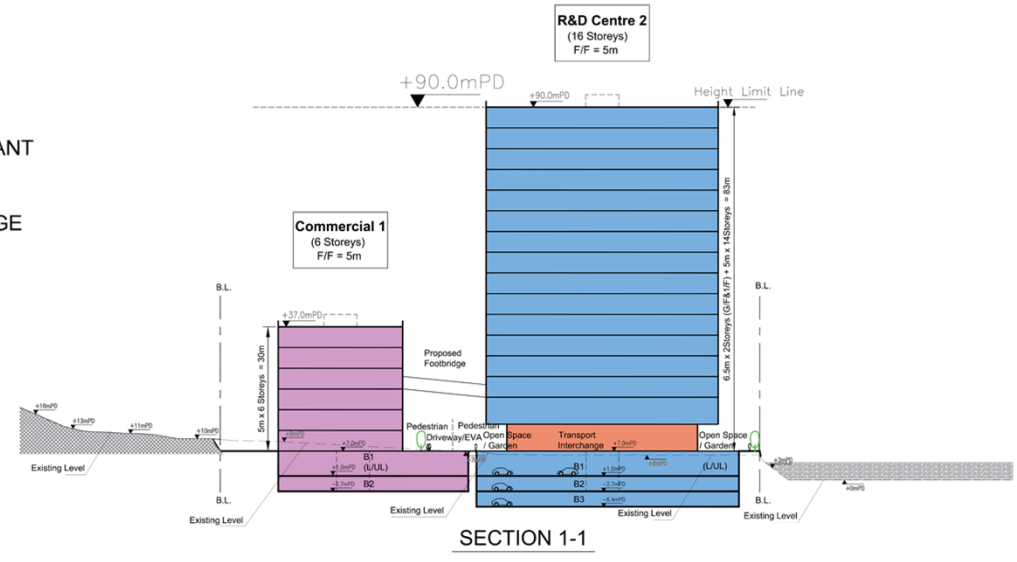

Job Title **APPLICATION FOR AMENDMENT OF PLAN UNDER SECTION 12A OF THE TOWN PLANNING ORDINANCE (CAP. 131) FOR PROPOSED INNOVATION AND TECHNOLOGY HUB AT VARIOUS LOTS IN D.D. 82 AND D.D. 86 AND ADJOINING GOVERNMENT LAND, MAN KAM TO, NEW TERRITORIES**

FIGURE 3.5

Date	Scale	Drawing Title
FEB 25	NTS	SECTION PLAN OF INDICATIVE SCHEME
Drawn	Job No.	
CKTY	287082-02	



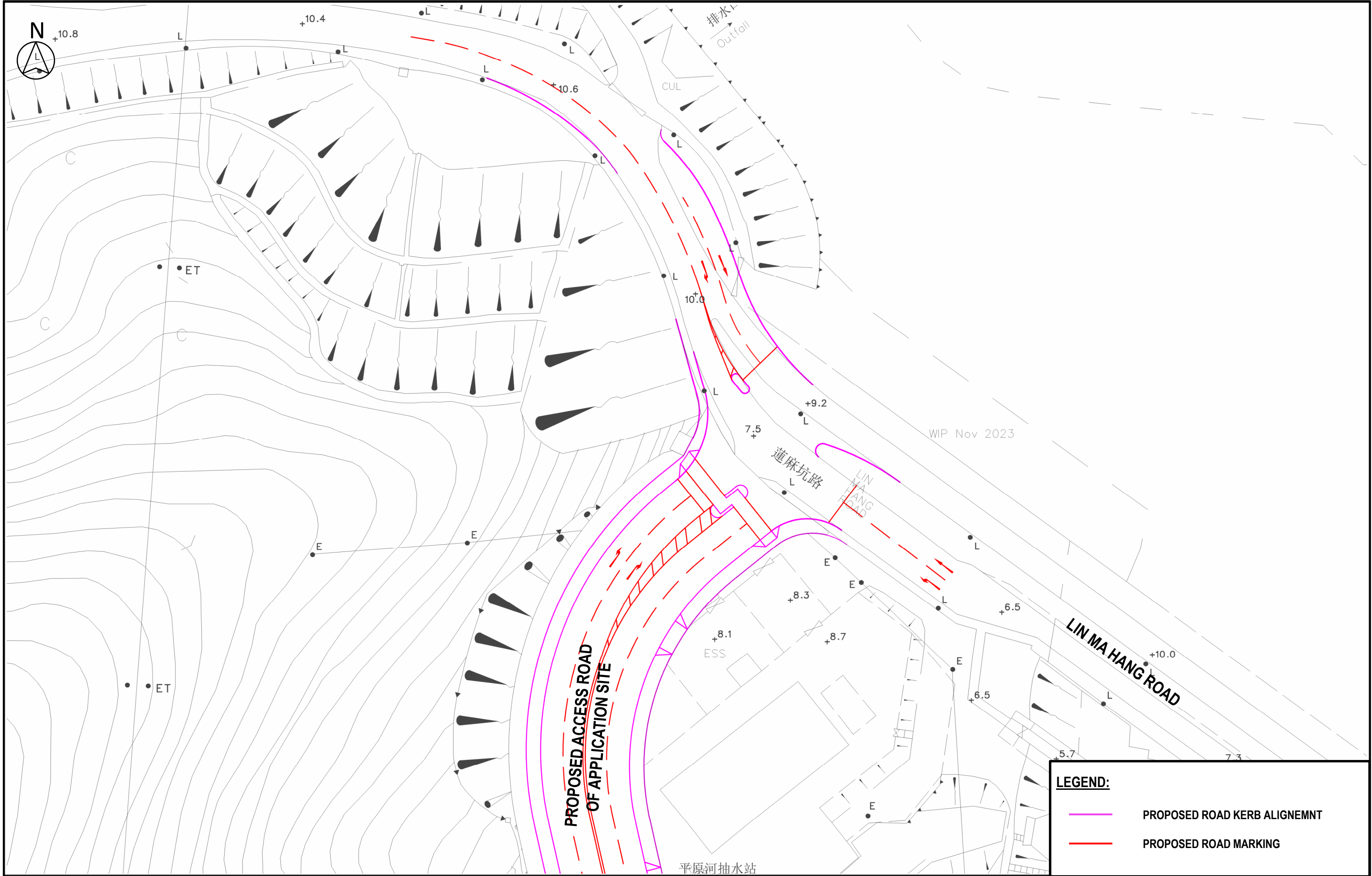

LEGEND:

- PROPOSED ROAD KERB ALIGNMENT
- - - PROPOSED ROAD MARKING

Job Title **APPLICATION FOR AMENDMENT OF PLAN UNDER SECTION 12A OF THE TOWN PLANNING ORDINANCE (CAP. 131) FOR PROPOSED INNOVATION AND TECHNOLOGY HUB AT VARIOUS LOTS IN D.D. 82 AND D.D. 86 AND ADJOINING GOVERNMENT LAND, MAN KAM TO, NEW TERRITORIES**

FIGURE 3.6

Date	Scale	Drawing Title
FEB 25	NTS	PROPOSED ACCESSES ROAD AND SIGNALISED JUNCTION OF INDICATIVE SCHEME
Drawn	Job No.	
CKTY	287082-02	

PROPOSED ACCESSES ROAD AND SIGNALISED JUNCTION OF INDICATIVE SCHEME



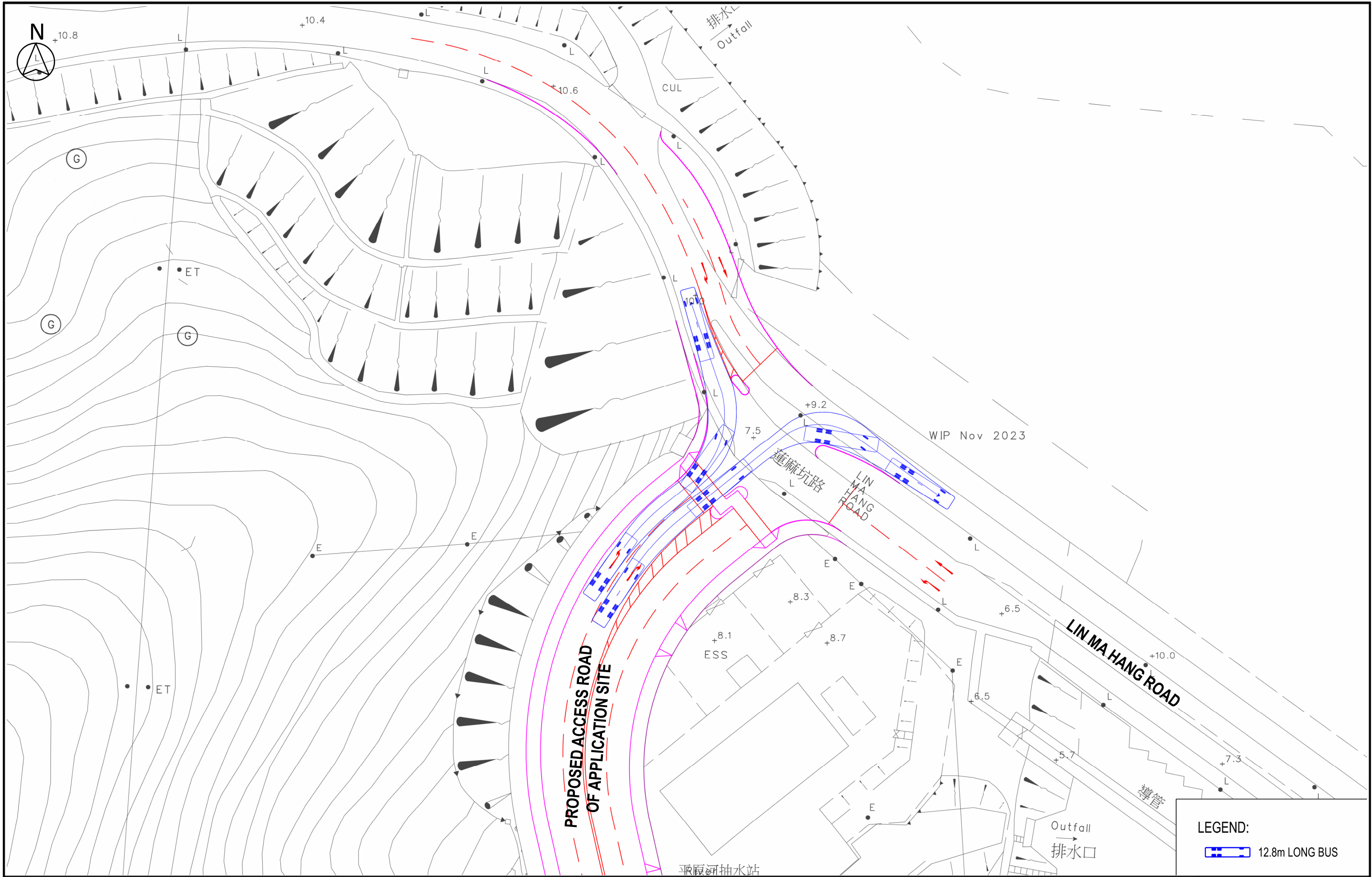

Job Title **APPLICATION FOR AMENDMENT OF PLAN UNDER SECTION 12A OF THE TOWN PLANNING ORDINANCE (CAP. 131) FOR PROPOSED INNOVATION AND TECHNOLOGY HUB AT VARIOUS LOTS IN D.D. 82 AND D.D. 86 AND ADJOINING GOVERNMENT LAND, MAN KAM TO, NEW TERRITORIES**

FIGURE 3.7

Date	Scale
FEB 25	NTS
Drawn	Job No.
CKTY	287082-02

Drawing Title
SWEPT PATH ANALYSIS OF THE PROPOSED ACCESS ROAD AND SIGNALISED JUNCTION OF INDICATIVE SCHEME – PROPOSED ACCESS ROAD



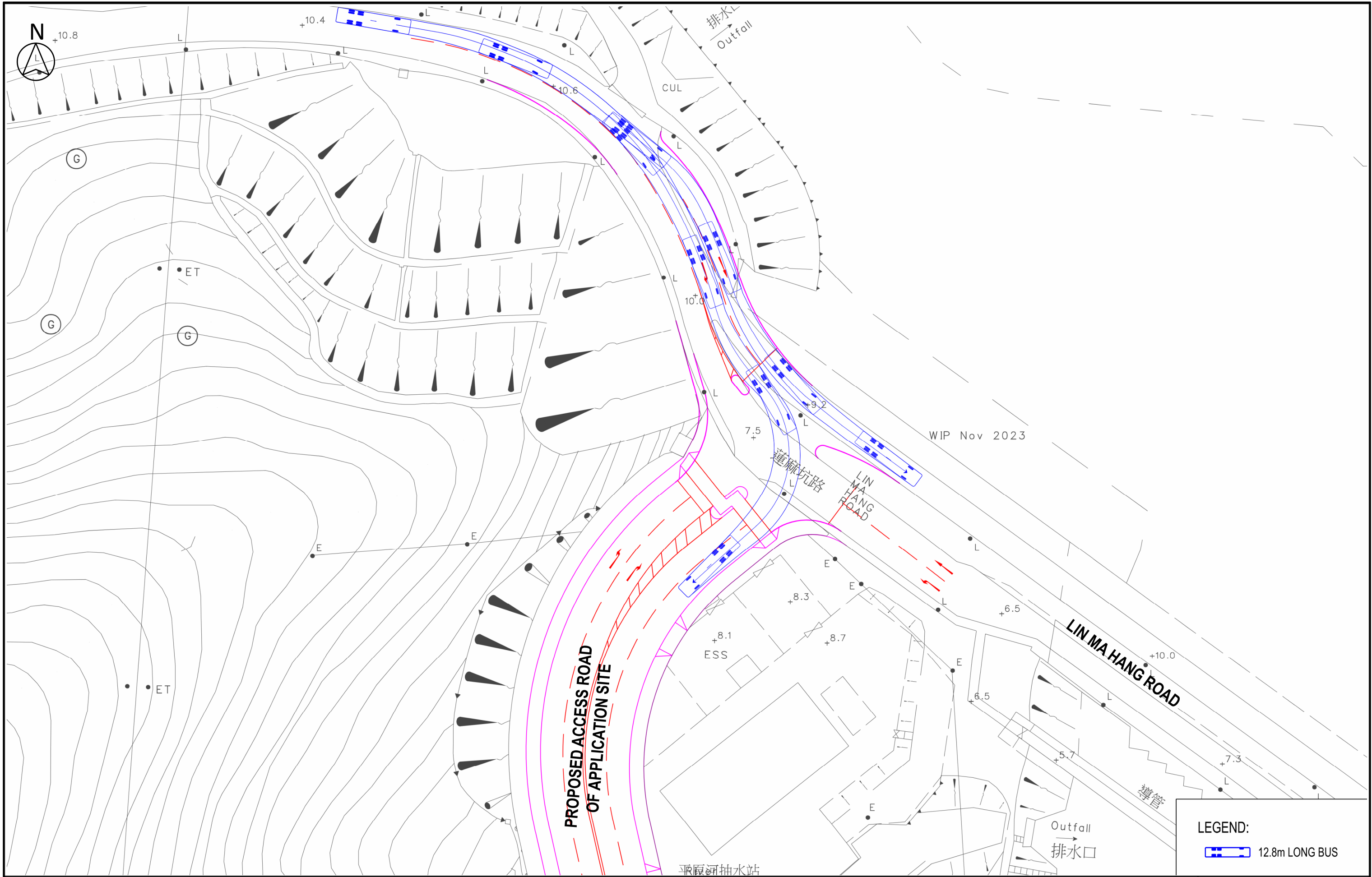

Job Title **APPLICATION FOR AMENDMENT OF PLAN UNDER SECTION 12A OF THE TOWN PLANNING ORDINANCE (CAP. 131) FOR PROPOSED INNOVATION AND TECHNOLOGY HUB AT VARIOUS LOTS IN D.D. 82 AND D.D. 86 AND ADJOINING GOVERNMENT LAND, MAN KAM TO, NEW TERRITORIES**

FIGURE 3.8

Date	Scale
FEB 25	NTS
Drawn	Job No.
CKTY	287082-02

Drawing Title **SWEPT PATH ANALYSIS OF THE PROPOSED ACCESSES ROAD AND SIGNALISED JUNCTION OF INDICATIVE SCHEME – LIN MA HANG ROAD EASTBOUND**



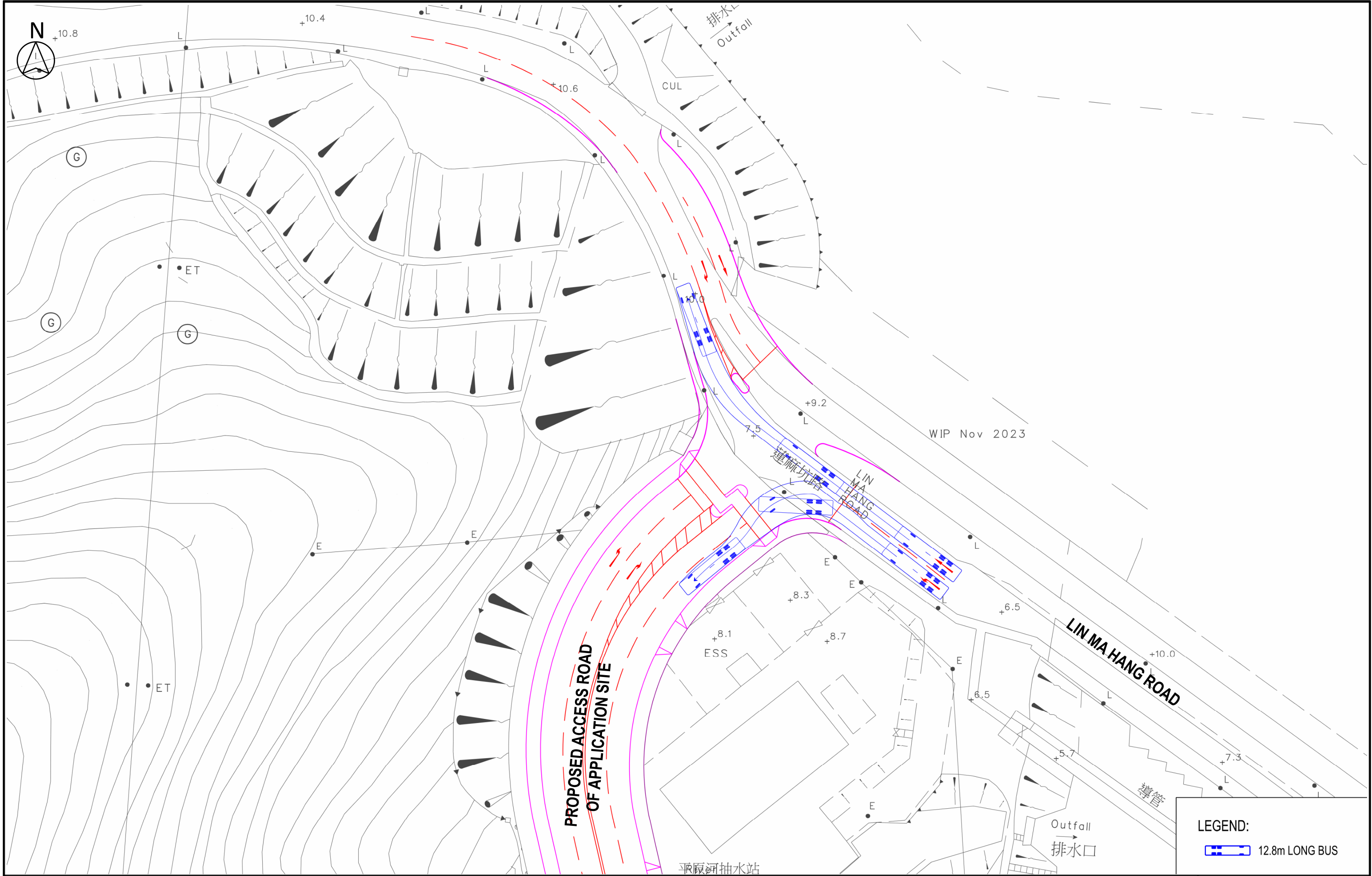

Job Title **APPLICATION FOR AMENDMENT OF PLAN UNDER SECTION 12A OF THE TOWN PLANNING ORDINANCE (CAP. 131) FOR PROPOSED INNOVATION AND TECHNOLOGY HUB AT VARIOUS LOTS IN D.D. 82 AND D.D. 86 AND ADJOINING GOVERNMENT LAND, MAN KAM TO, NEW TERRITORIES**

FIGURE 3.9



Date **FEB 25**
 Scale **NTS**
 Drawn **CKTY**
 Job No. **287082-02**

Drawing Title **SWEPT PATH ANALYSIS OF THE PROPOSED ACCESSES ROAD AND SIGNALISED JUNCTION OF INDICATIVE SCHEME – LIN MA HANG ROAD WESTBOUND**

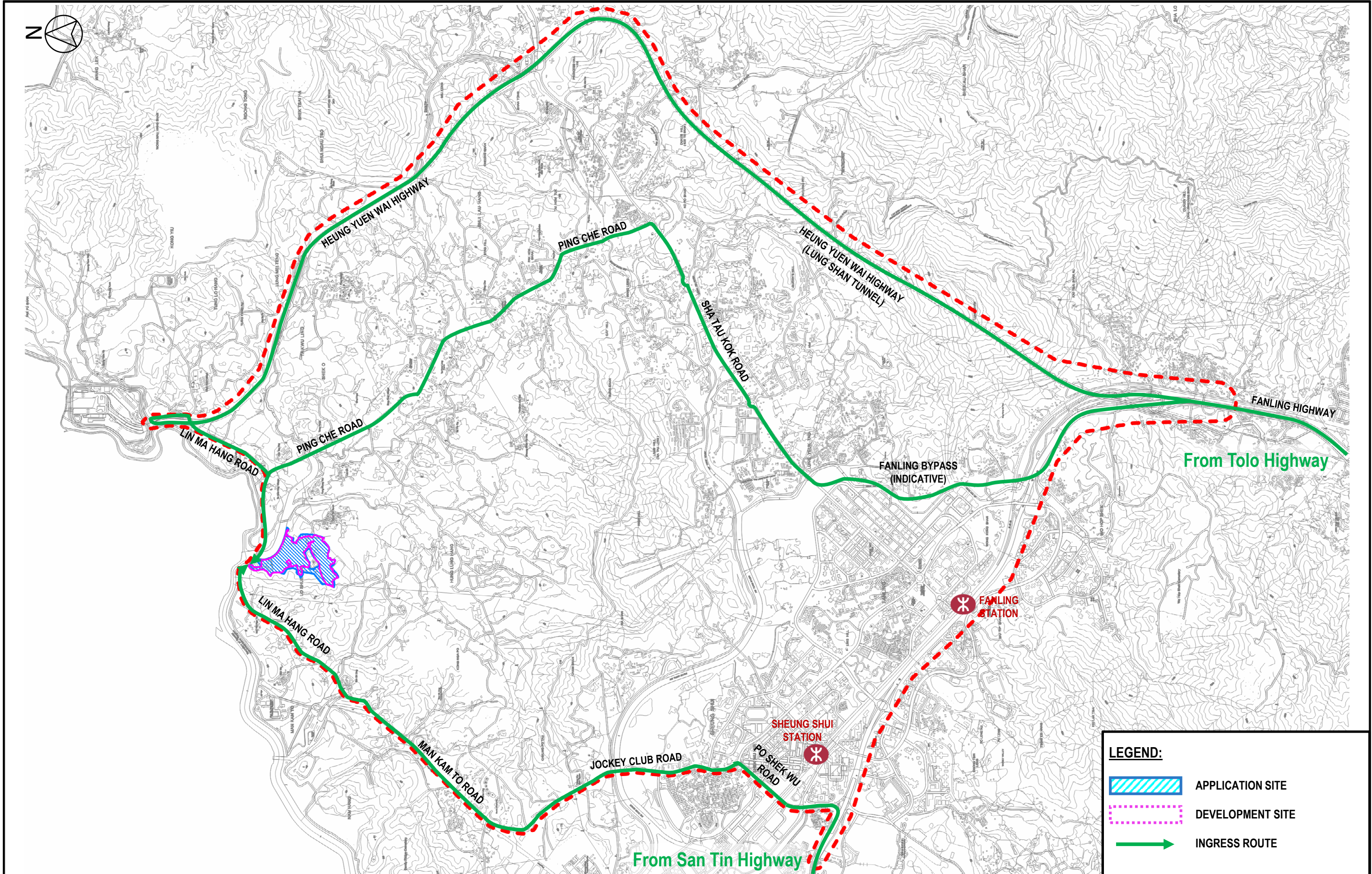



LEGEND:

-  APPLICATION SITE
-  DEVELOPMENT SITE
-  INGRESS ROUTE

Job Title **APPLICATION FOR AMENDMENT OF PLAN UNDER SECTION 12A OF THE TOWN PLANNING ORDINANCE (CAP. 131) FOR PROPOSED INNOVATION AND TECHNOLOGY HUB AT VARIOUS LOTS IN D.D. 82 AND D.D. 86 AND ADJOINING GOVERNMENT LAND, MAN KAM TO, NEW TERRITORIES**

FIGURE 3.10

Date	Scale	Drawing Title
FEB 25	NTS	MAJOR INGRESS VEHICULAR ROUTES OF INDICATIVE SCHEME
Drawn	Job No.	
CKTY	287082-02	



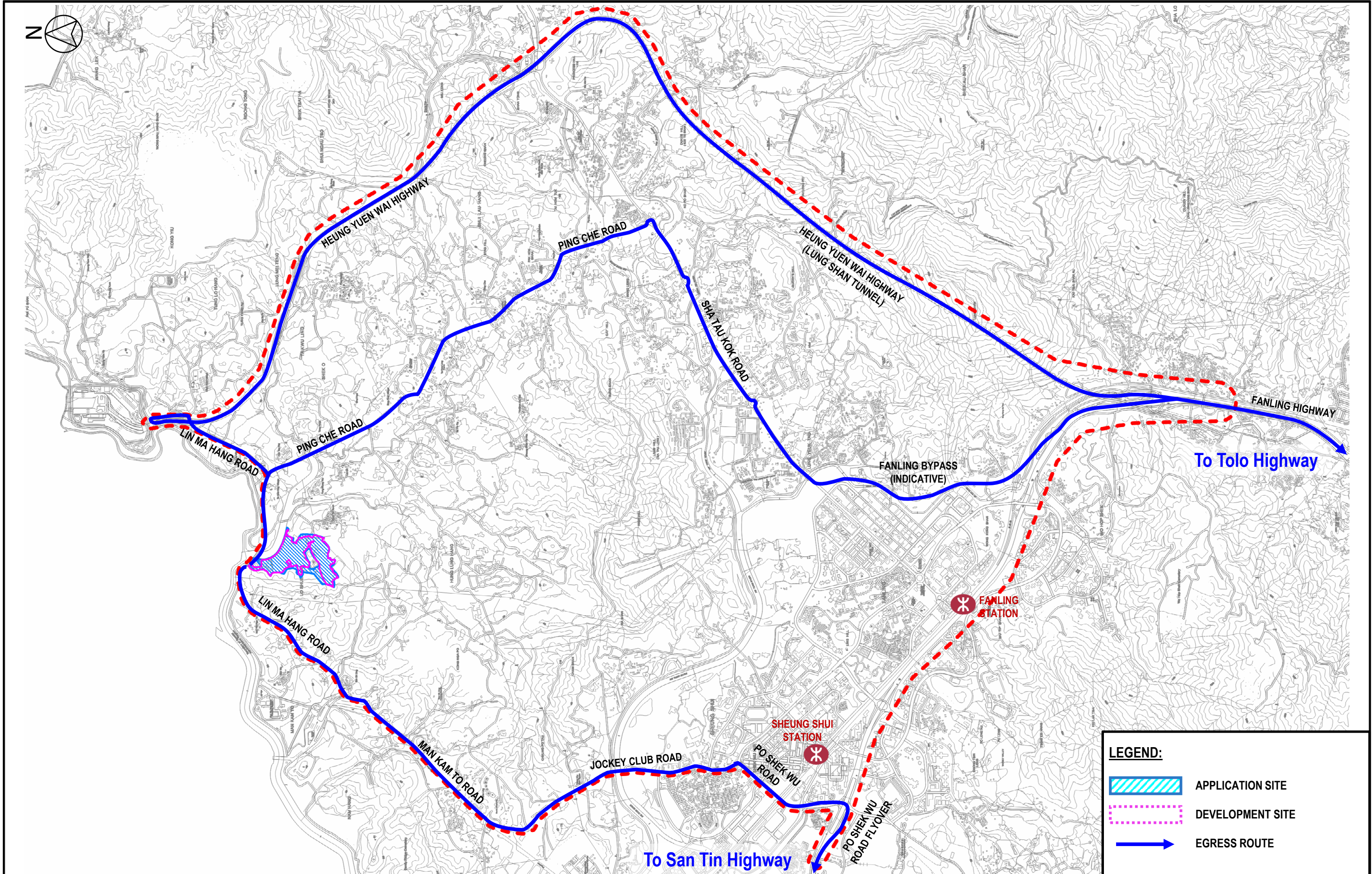

Job Title APPLICATION FOR AMENDMENT OF PLAN UNDER SECTION 12A OF THE TOWN PLANNING ORDINANCE (CAP. 131) FOR PROPOSED INNOVATION AND TECHNOLOGY HUB AT VARIOUS LOTS IN D.D. 82 AND D.D. 86 AND ADJOINING GOVERNMENT LAND, MAN KAM TO, NEW TERRITORIES

FIGURE 3.11

Date	Scale	Drawing Title
FEB 25	NTS	MAJOR EGRESS VEHICULAR ROUTES OF INDICATIVE SCHEME
Drawn	Job No.	
CKTY	287082-02	

MAJOR EGRESS VEHICULAR ROUTES OF INDICATIVE SCHEME

ARUP

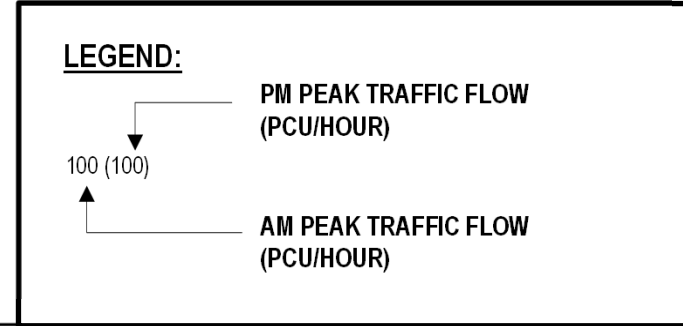
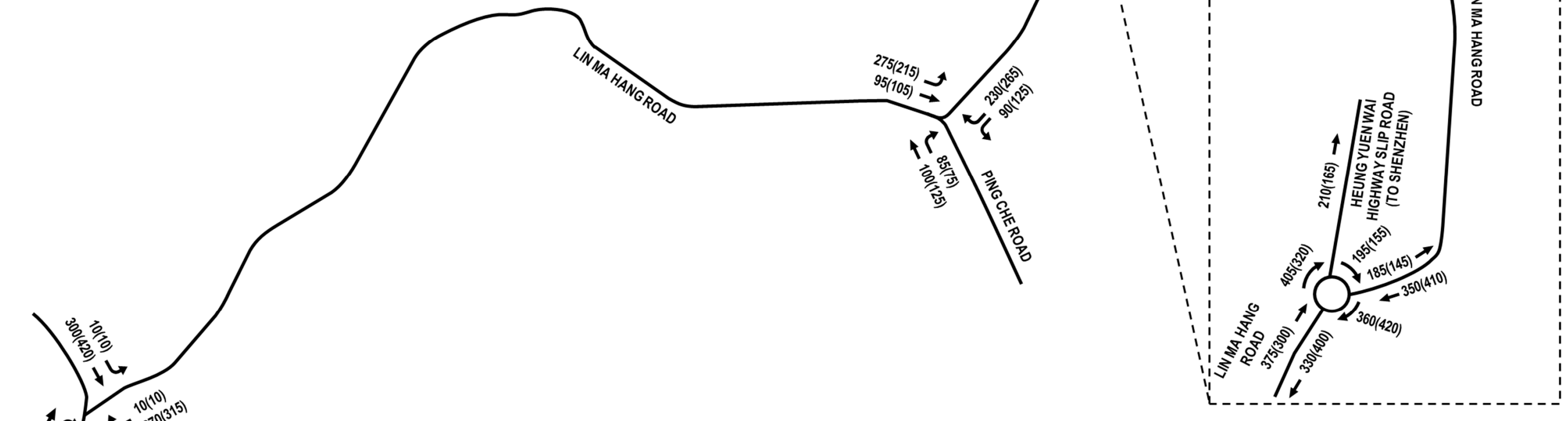
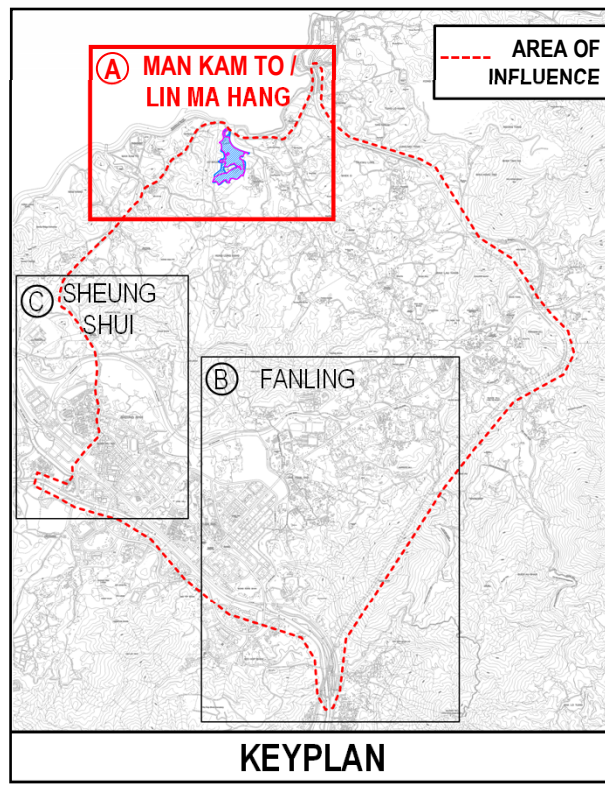

Job Title: APPLICATION FOR AMENDMENT OF PLAN UNDER SECTION 12A OF THE TOWN PLANNING ORDINANCE (CAP. 131) FOR PROPOSED INNOVATION AND TECHNOLOGY HUB AT VARIOUS LOTS IN D.D. 82 AND D.D. 86 AND ADJOINING GOVERNMENT LAND, MAN KAM TO, NEW TERRITORIES

FIGURE 4.1

Date	Scale
FEB 25	NTS
Drawn	Job No.
CKTY	287082-02

YEAR 2031 REFERENCE TRAFFIC FLOW – MAN KAM TO / LIN MA HANG AREA



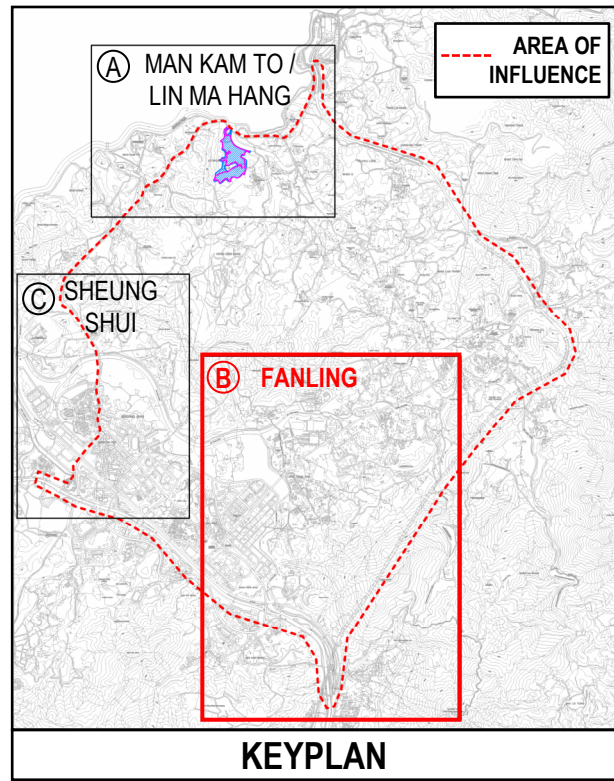
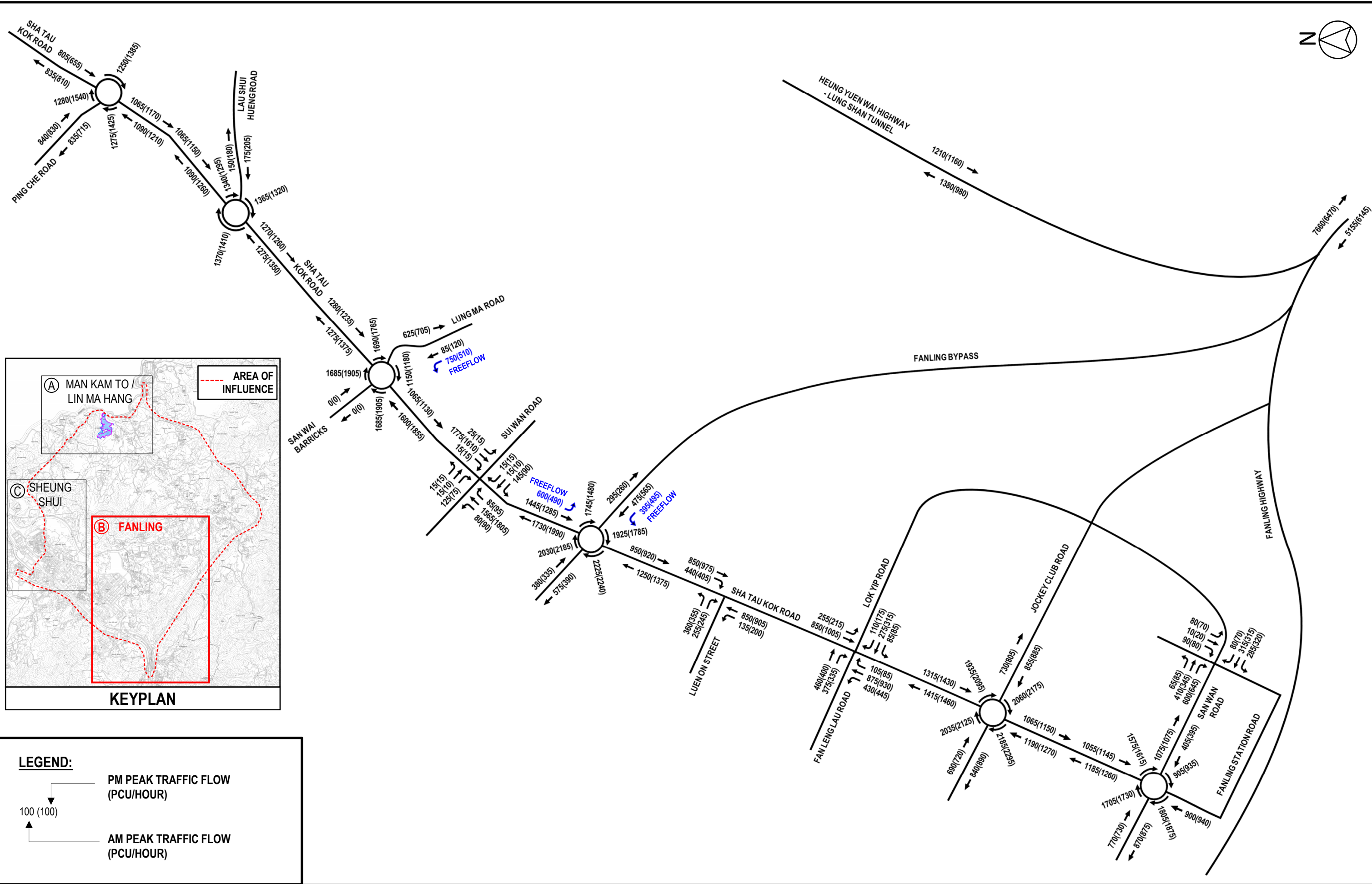

LEGEND:

	PM PEAK TRAFFIC FLOW (PCU/HOUR)
	AM PEAK TRAFFIC FLOW (PCU/HOUR)

100 (100)

Job Title: APPLICATION FOR AMENDMENT OF PLAN UNDER SECTION 12A OF THE TOWN PLANNING ORDINANCE (CAP. 131) FOR PROPOSED INNOVATION AND TECHNOLOGY HUB AT VARIOUS LOTS IN D.D. 82 AND D.D. 86 AND ADJOINING GOVERNMENT LAND, MAN KAM TO, NEW TERRITORIES

FIGURE 4.2

Date	Scale	Drawing Title
FEB 25	NTS	YEAR 2031 REFERENCE TRAFFIC FLOW – FANLING AREA
Drawn	Job No.	
CKTY	287082-02	



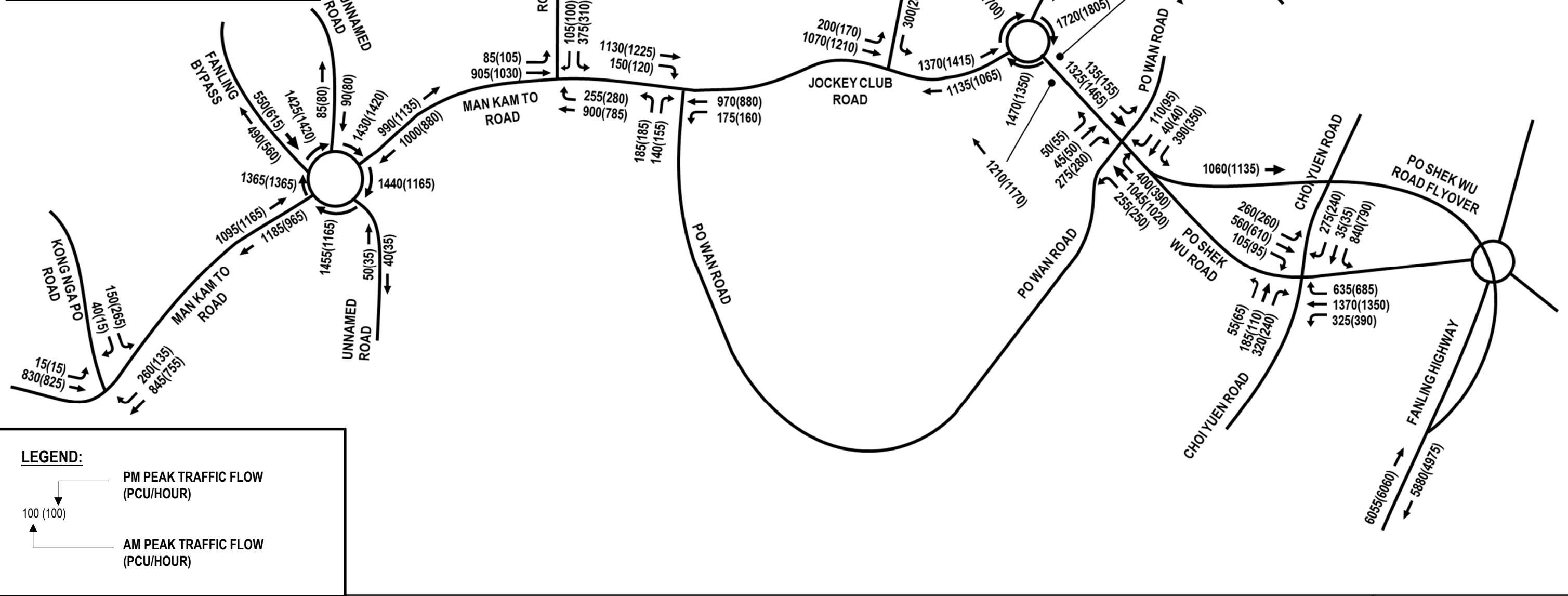
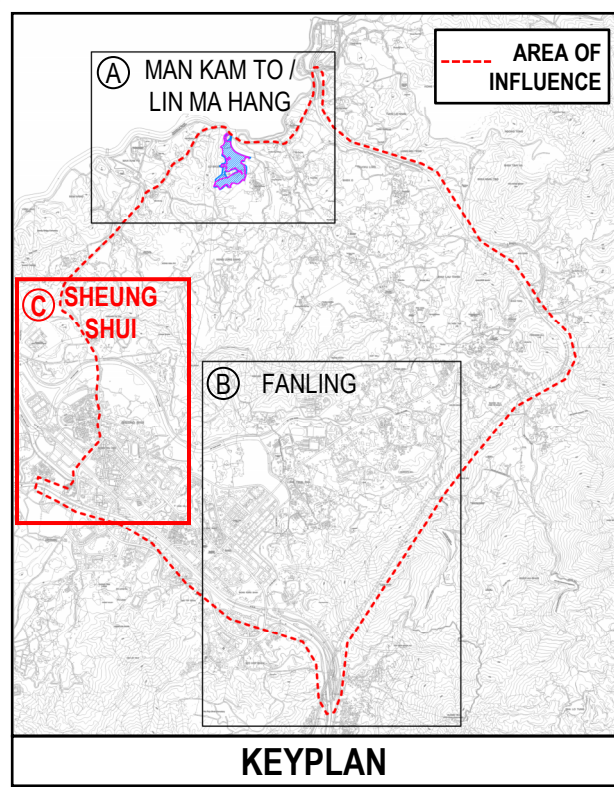

Job Title: APPLICATION FOR AMENDMENT OF PLAN UNDER SECTION 12A OF THE TOWN PLANNING ORDINANCE (CAP. 131) FOR PROPOSED INNOVATION AND TECHNOLOGY HUB AT VARIOUS LOTS IN D.D. 82 AND D.D. 86 AND ADJOINING GOVERNMENT LAND, MAN KAM TO, NEW TERRITORIES

FIGURE 4.3

Date	Scale	Drawing Title
FEB 25	NTS	YEAR 2031 REFERENCE TRAFFIC FLOW – SHEUNG SHUI AREA
Drawn	Job No.	
CKTY	287082-02	

YEAR 2031 REFERENCE TRAFFIC FLOW – SHEUNG SHUI AREA



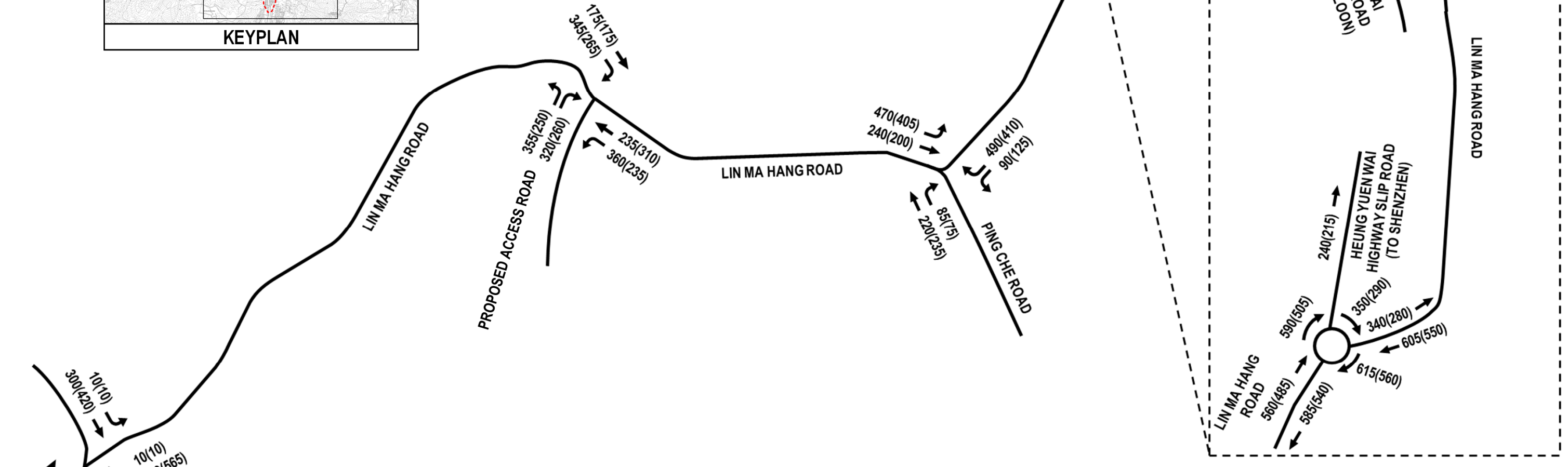
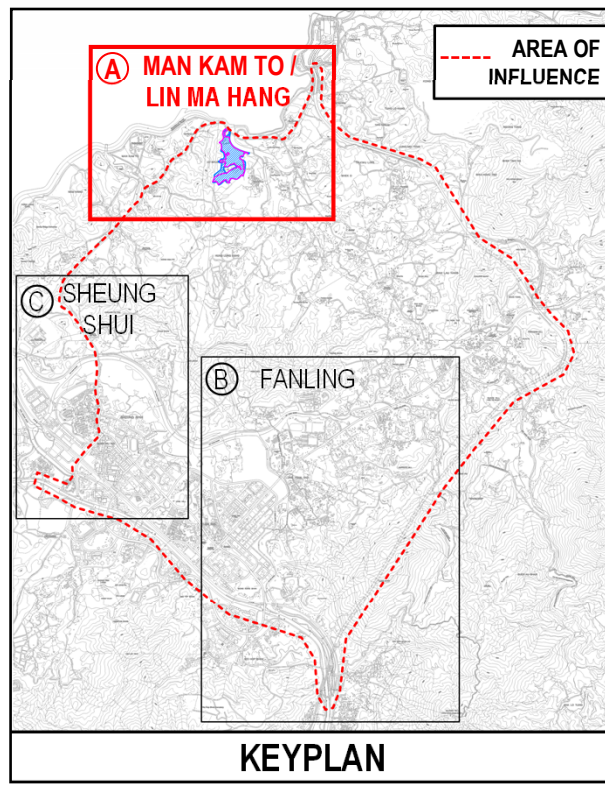

LEGEND:

PM PEAK TRAFFIC FLOW (PCU/HOUR)
 AM PEAK TRAFFIC FLOW (PCU/HOUR)

100 (100)

Job Title: APPLICATION FOR AMENDMENT OF PLAN UNDER SECTION 12A OF THE TOWN PLANNING ORDINANCE (CAP. 131) FOR PROPOSED INNOVATION AND TECHNOLOGY HUB AT VARIOUS LOTS IN D.D. 82 AND D.D. 86 AND ADJOINING GOVERNMENT LAND, MAN KAM TO, NEW TERRITORIES

FIGURE 4.4

Date	Scale	Drawing Title
FEB 25	NTS	YEAR 2031 DESIGN TRAFFIC FLOW – MAN KAM TO / LIN MA HANG AREA
Drawn	Job No.	
CKTY	287082-02	



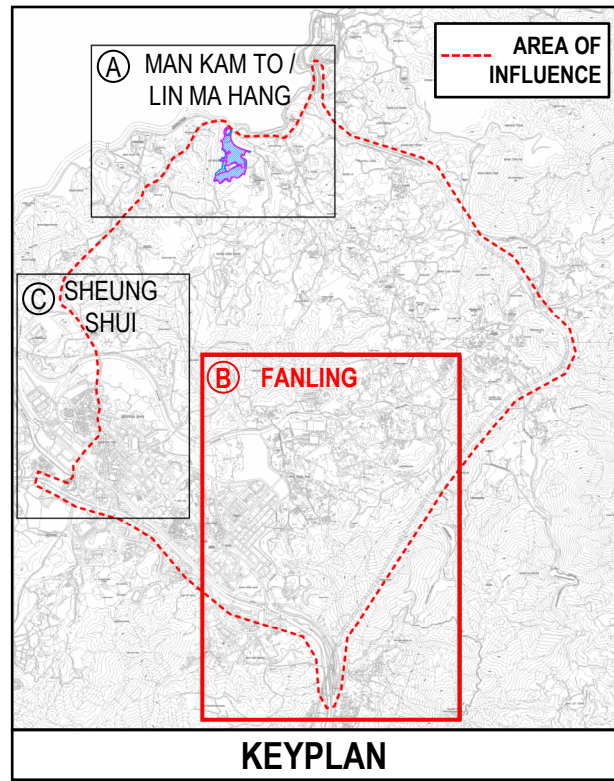

Job Title: APPLICATION FOR AMENDMENT OF PLAN UNDER SECTION 12A OF THE TOWN PLANNING ORDINANCE (CAP. 131) FOR PROPOSED INNOVATION AND TECHNOLOGY HUB AT VARIOUS LOTS IN D.D. 82 AND D.D. 86 AND ADJOINING GOVERNMENT LAND, MAN KAM TO, NEW TERRITORIES

FIGURE 4.5

Date	Scale	Drawing Title
FEB 25	NTS	YEAR 2031 DESIGN TRAFFIC FLOW – FANLING AREA
Drawn	Job No.	
CKTY	287082-02	

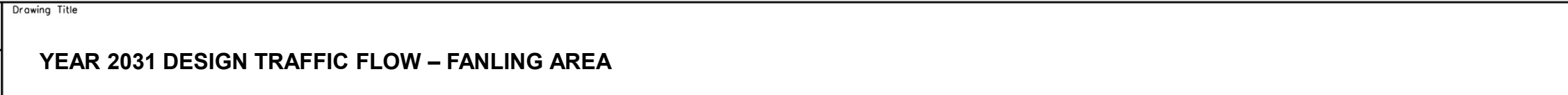

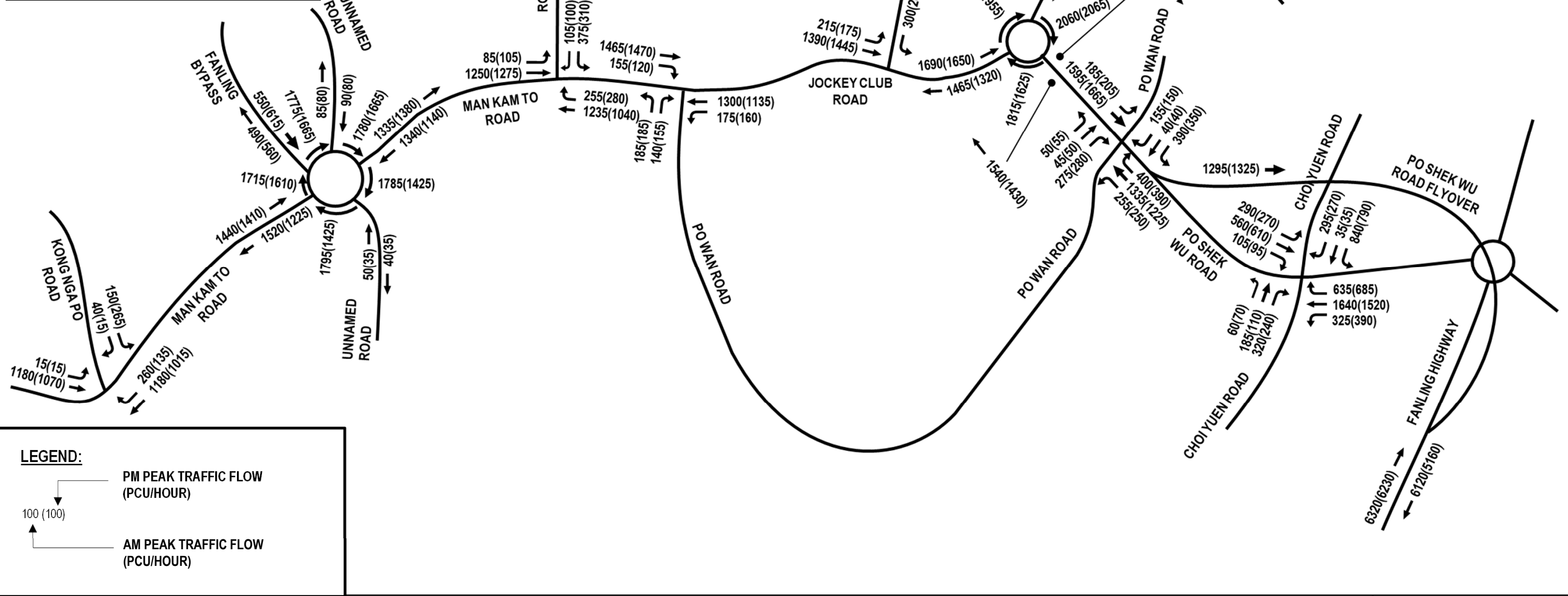
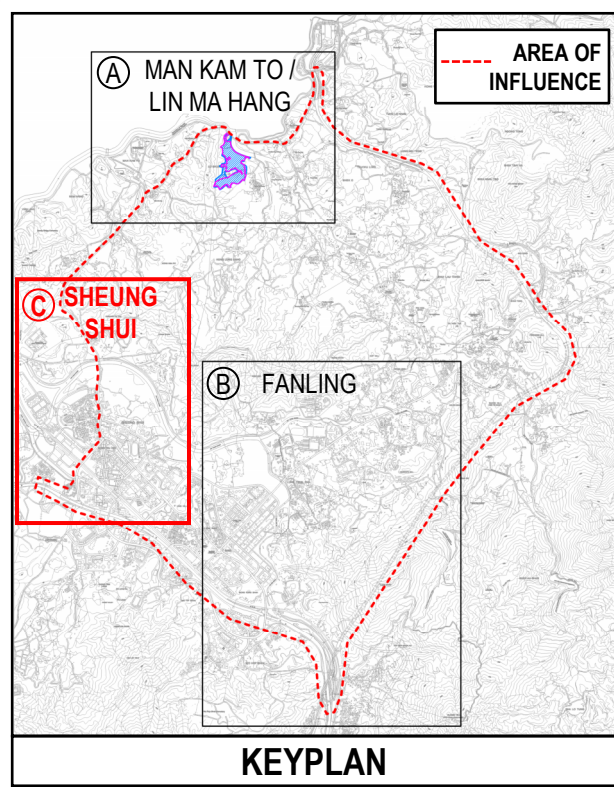

Job Title: APPLICATION FOR AMENDMENT OF PLAN UNDER SECTION 12A OF THE TOWN PLANNING ORDINANCE (CAP. 131) FOR PROPOSED INNOVATION AND TECHNOLOGY HUB AT VARIOUS LOTS IN D.D. 82 AND D.D. 86 AND ADJOINING GOVERNMENT LAND, MAN KAM TO, NEW TERRITORIES

FIGURE 4.6

Date	Scale	Drawing Title
FEB 25	NTS	YEAR 2031 DESIGN TRAFFIC FLOW – SHEUNG SHUI AREA
Drawn	Job No.	
CKTY	287082-02	



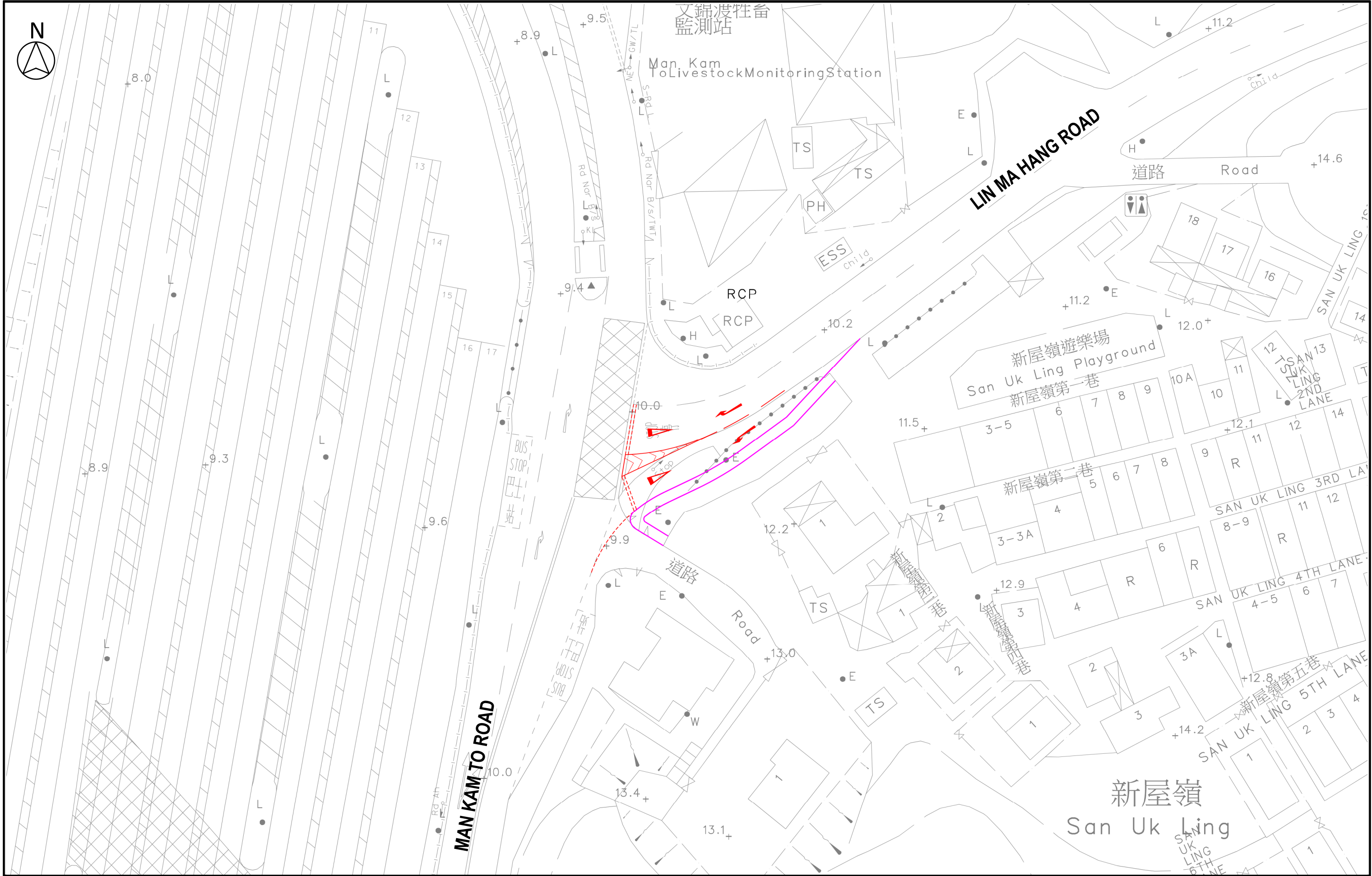

Job Title **APPLICATION FOR AMENDMENT OF PLAN UNDER SECTION 12A OF THE TOWN PLANNING ORDINANCE (CAP. 131) FOR PROPOSED INNOVATION AND TECHNOLOGY HUB AT VARIOUS LOTS IN D.D. 82 AND D.D. 86 AND ADJOINING GOVERNMENT LAND, MAN KAM TO, NEW TERRITORIES**

FIGURE 4.7

Date	Scale	Drawing Title
FEB 25	NTS	PROPOSED JUNCTION MODIFICATION FOR J1 – LIN MA HANG ROAD / MAN KAM TO ROAD
Drawn	Job No.	
CKTY	287082-02	

PROPOSED JUNCTION MODIFICATION FOR J1 – LIN MA HANG ROAD / MAN KAM TO ROAD

ARUP

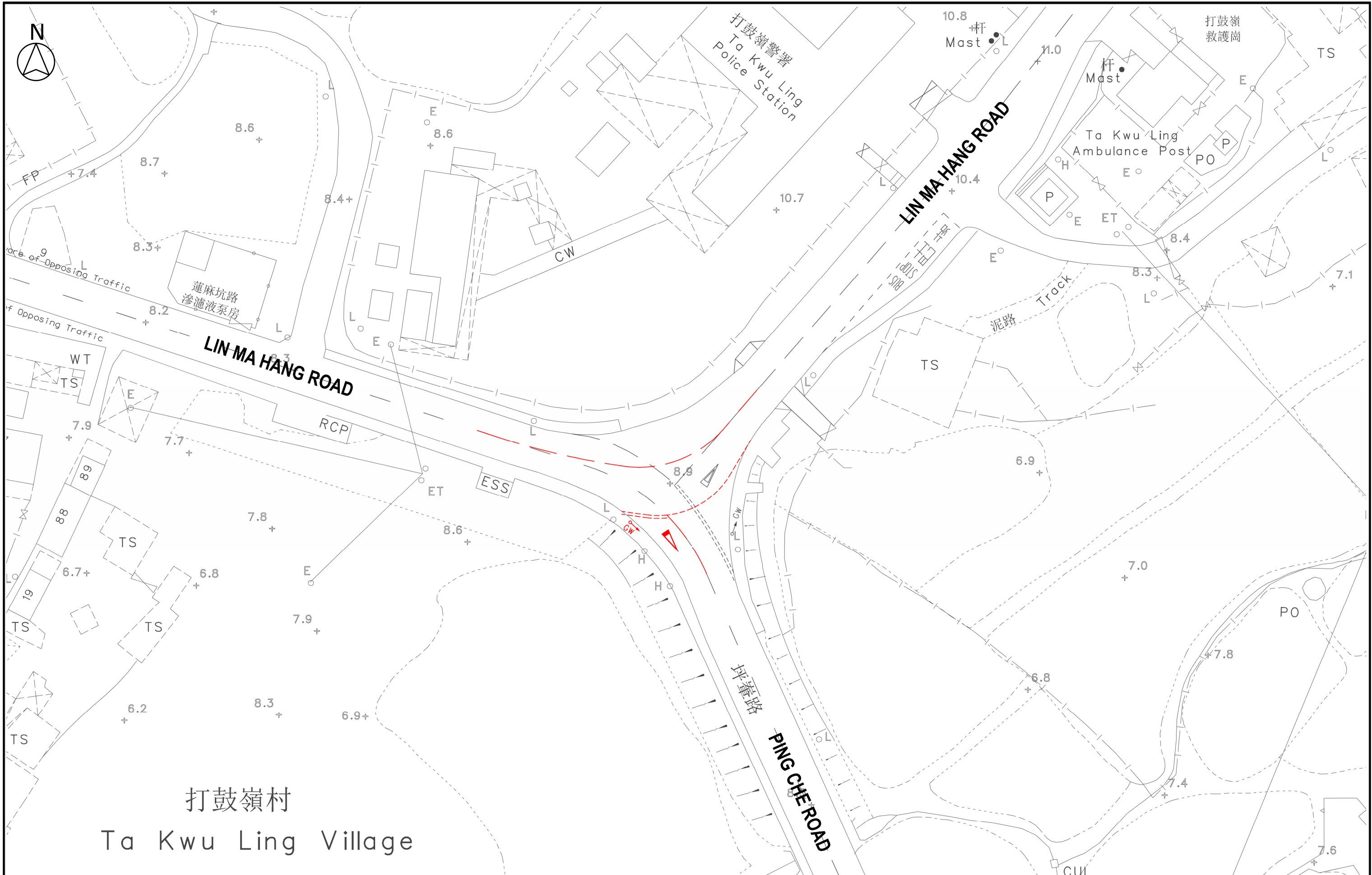

Job Title **APPLICATION FOR AMENDMENT OF PLAN UNDER SECTION 12A OF THE TOWN PLANNING ORDINANCE (CAP. 131) FOR PROPOSED INNOVATION AND TECHNOLOGY HUB AT VARIOUS LOTS IN D.D. 82 AND D.D. 86 AND ADJOINING GOVERNMENT LAND, MAN KAM TO, NEW TERRITORIES**

FIGURE 4.9

Date	Scale
FEB 25	NTS
Drawn	Job No.
CKTY	287082-02

Drawing Title **PROPOSED JUNCTION MODIFICATION FOR J2 - LIN MA HANG ROAD / PING CHE ROAD**



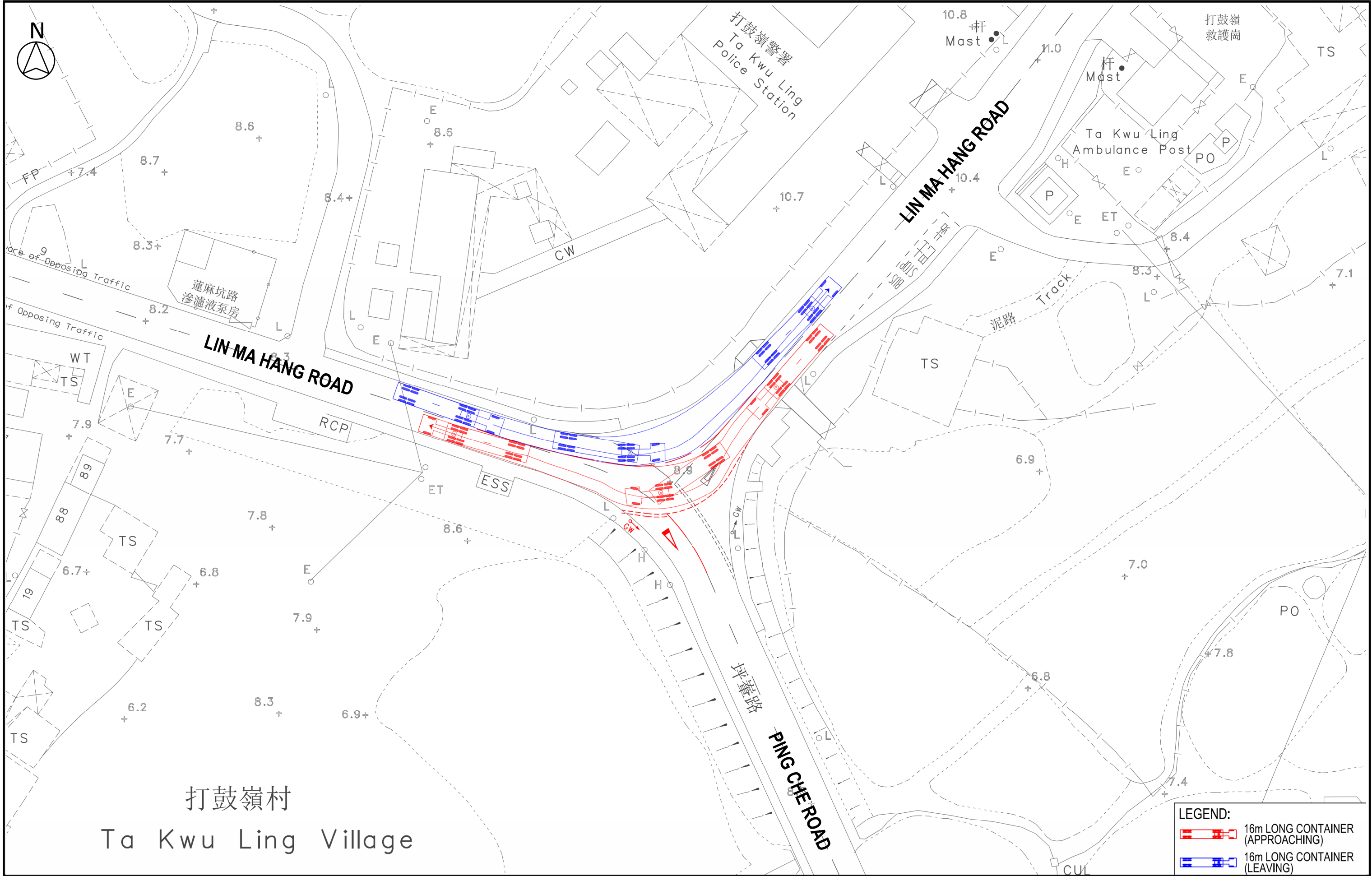

LEGEND:

- 16m LONG CONTAINER (APPROACHING)
- 16m LONG CONTAINER (LEAVING)

Job Title **APPLICATION FOR AMENDMENT OF PLAN UNDER SECTION 12A OF THE TOWN PLANNING ORDINANCE (CAP. 131) FOR PROPOSED INNOVATION AND TECHNOLOGY HUB AT VARIOUS LOTS IN D.D. 82 AND D.D. 86 AND ADJOINING GOVERNMENT LAND, MAN KAM TO, NEW TERRITORIES**

FIGURE 4.10

Date	Scale
FEB 25	NTS
Drawn	Job No.
CKTY	287082-02

Drawing Title **SWEPT PATH ANALYSIS OF PROPOSED JUNCTION MODIFICATION FOR J2 – LIN MA HANG ROAD / PING CHE ROAD**



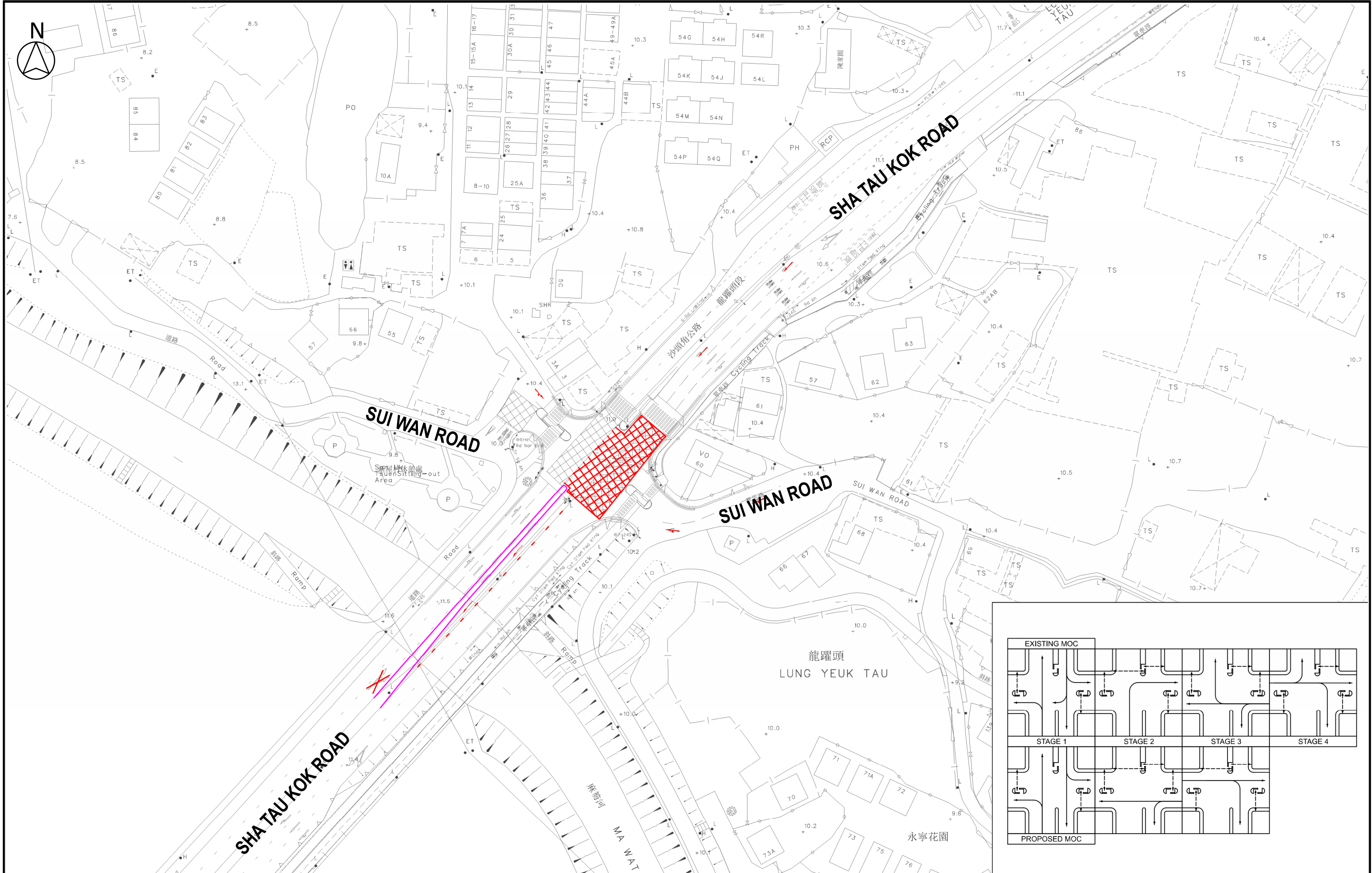

Job Title **APPLICATION FOR AMENDMENT OF PLAN UNDER SECTION 12A OF THE TOWN PLANNING ORDINANCE (CAP. 131) FOR PROPOSED INNOVATION AND TECHNOLOGY HUB AT VARIOUS LOTS IN D.D. 82 AND D.D. 86 AND ADJOINING GOVERNMENT LAND, MAN KAM TO, NEW TERRITORIES**

FIGURE 4.11

Date **FEB 25**
 Scale **NTS**
 Drawn **CKTY**
 Job No. **287082-02**

Drawing Title **PROPOSED JUNCTION MODIFICATION FOR J8 – SHA TAU KOK ROAD / SUI WAN ROAD**



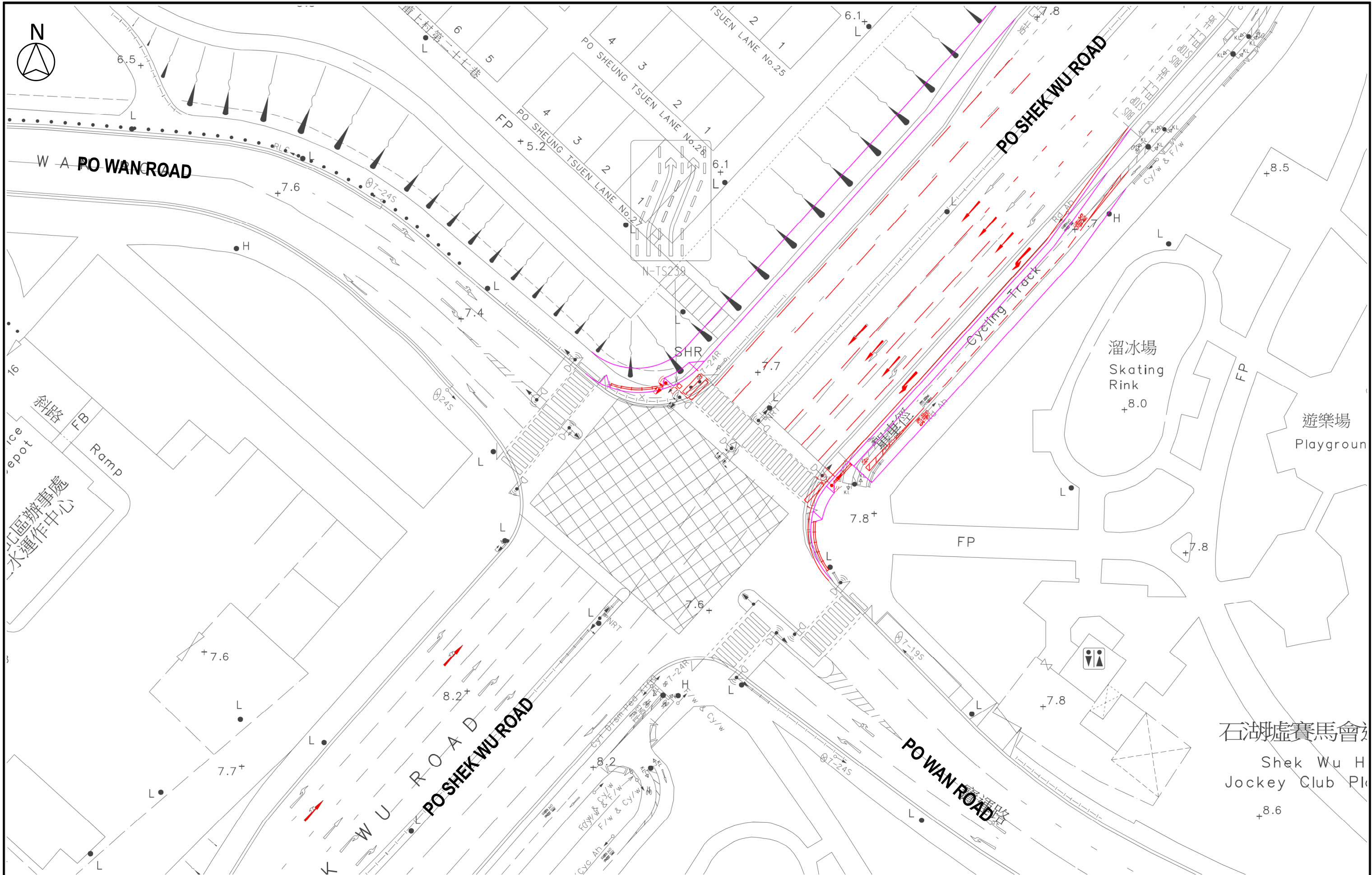

Job Title **APPLICATION FOR AMENDMENT OF PLAN UNDER SECTION 12A OF THE TOWN PLANNING ORDINANCE (CAP. 131) FOR PROPOSED INNOVATION AND TECHNOLOGY HUB AT VARIOUS LOTS IN D.D. 82 AND D.D. 86 AND ADJOINING GOVERNMENT LAND, MAN KAM TO, NEW TERRITORIES**

FIGURE 4.12

Date	Scale
FEB 25	NTS
Drawn	Job No.
CKTY	287082-02

Drawing Title **PROPOSED JUNCTION MODIFICATION FOR J13 – PO SHEK WU ROAD / PO WAN ROAD**



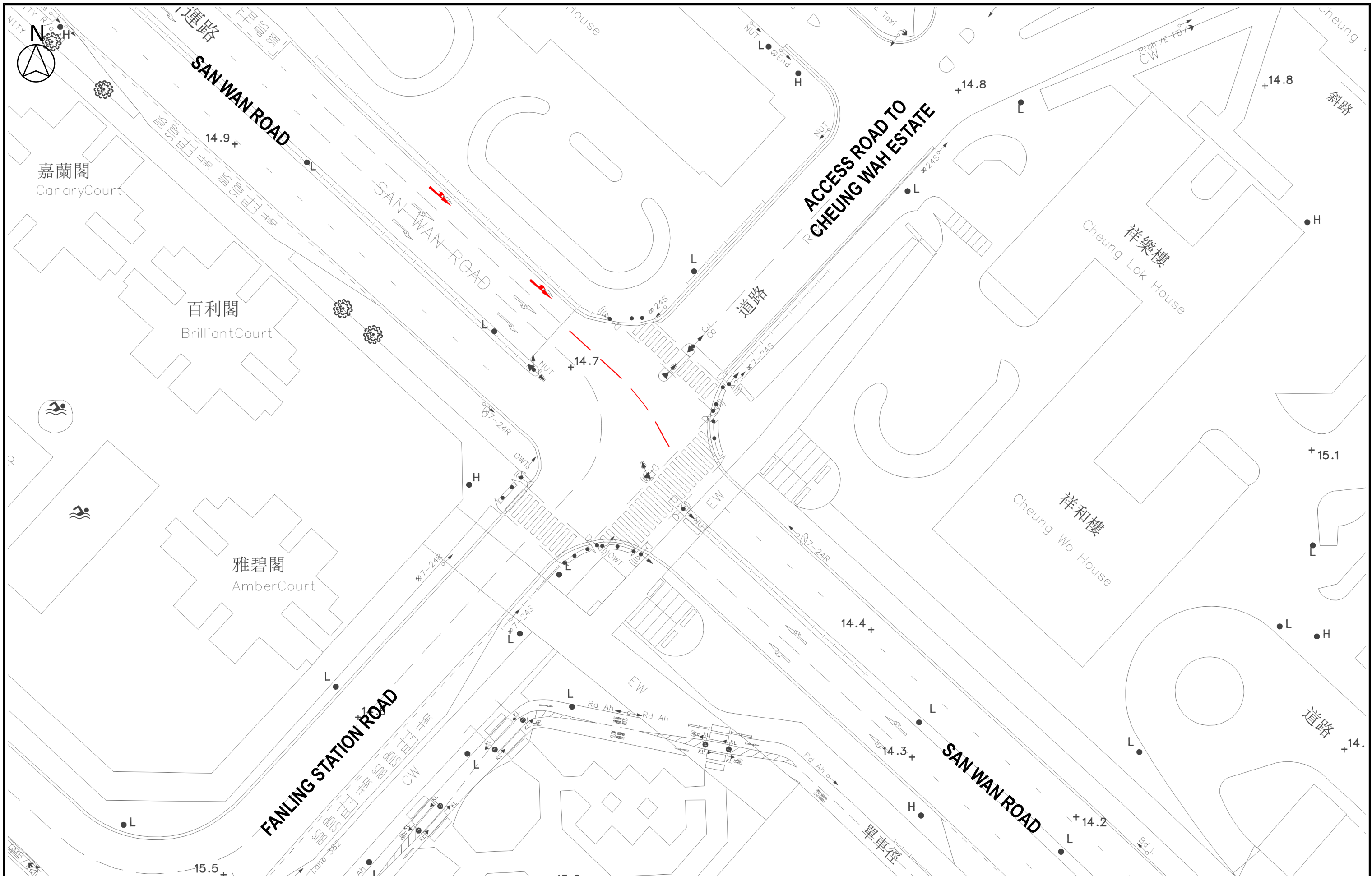



Job Title **APPLICATION FOR AMENDMENT OF PLAN UNDER SECTION 12A OF THE TOWN PLANNING ORDINANCE (CAP. 131) FOR PROPOSED INNOVATION AND TECHNOLOGY HUB AT VARIOUS LOTS IN D.D. 82 AND D.D. 86 AND ADJOINING GOVERNMENT LAND, MAN KAM TO, NEW TERRITORIES**

FIGURE 4.13

Date	Scale	Drawing Title
FEB 25	NTS	PROPOSED JUNCTION MODIFICATION FOR J23 – SAN WAN ROAD / FANLING STATION ROAD
Drawn	Job No.	
CKTY	287082-02	

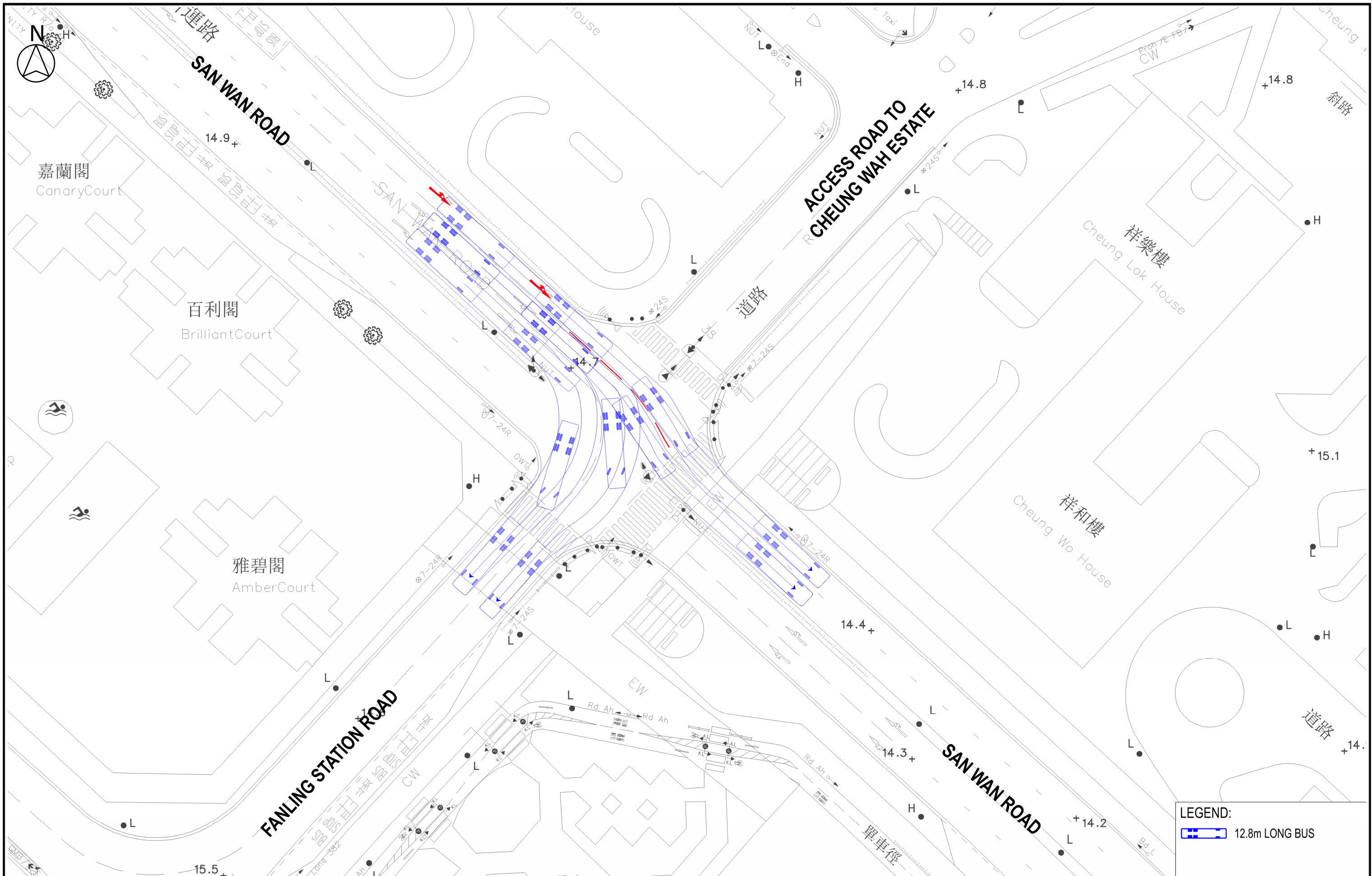



LEGEND:
 12.8m LONG BUS

Job Title **APPLICATION FOR AMENDMENT OF PLAN UNDER SECTION 12A OF THE TOWN PLANNING ORDINANCE (CAP. 131) FOR PROPOSED INNOVATION AND TECHNOLOGY HUB AT VARIOUS LOTS IN D.D. 82 AND D.D. 86 AND ADJOINING GOVERNMENT LAND, MAN KAM TO, NEW TERRITORIES**

FIGURE 4.14

Date	Scale
FEB 25	NTS
Drawn	Job No.
CKTY	287082-02

Drawing Title
SWEPT PATH ANALYSIS OF PROPOSED JUNCTION MODIFICATION FOR J23 – SAN WAN ROAD / FANLING STATION ROAD

ARUP

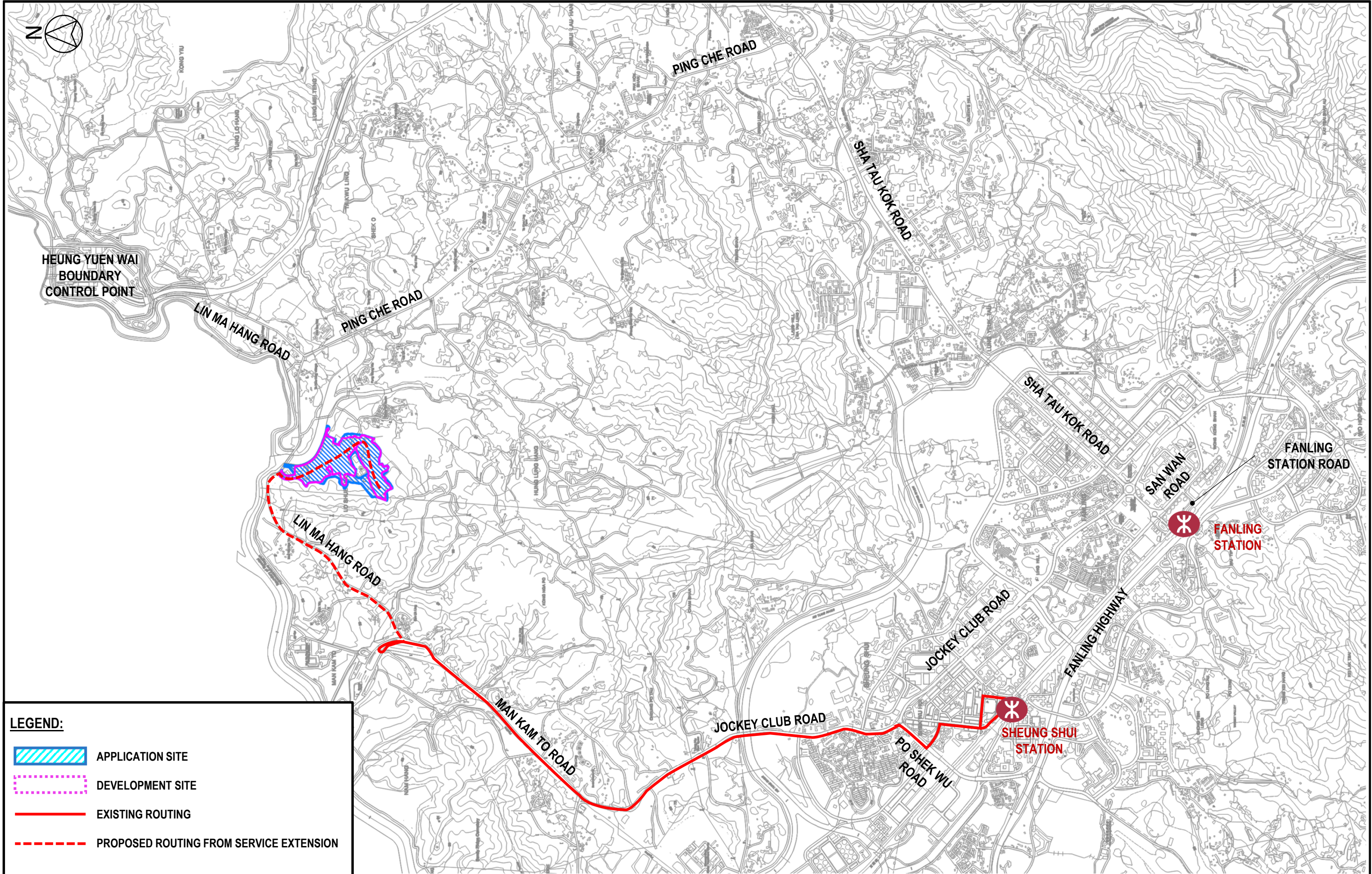

Job Title **APPLICATION FOR AMENDMENT OF PLAN UNDER SECTION 12A OF THE TOWN PLANNING ORDINANCE (CAP. 131) FOR PROPOSED INNOVATION AND TECHNOLOGY HUB AT VARIOUS LOTS IN D.D. 82 AND D.D. 86 AND ADJOINING GOVERNMENT LAND, MAN KAM TO, NEW TERRITORIES**

FIGURE 4.15

Date	Scale	Drawing Title
FEB 25	NTS	PROPOSED ROUTING OF KMB 73K FOR SERVICE EXTENSION TO THE APPLICATION SITE
Drawn	Job No.	
CKTY	287082-02	



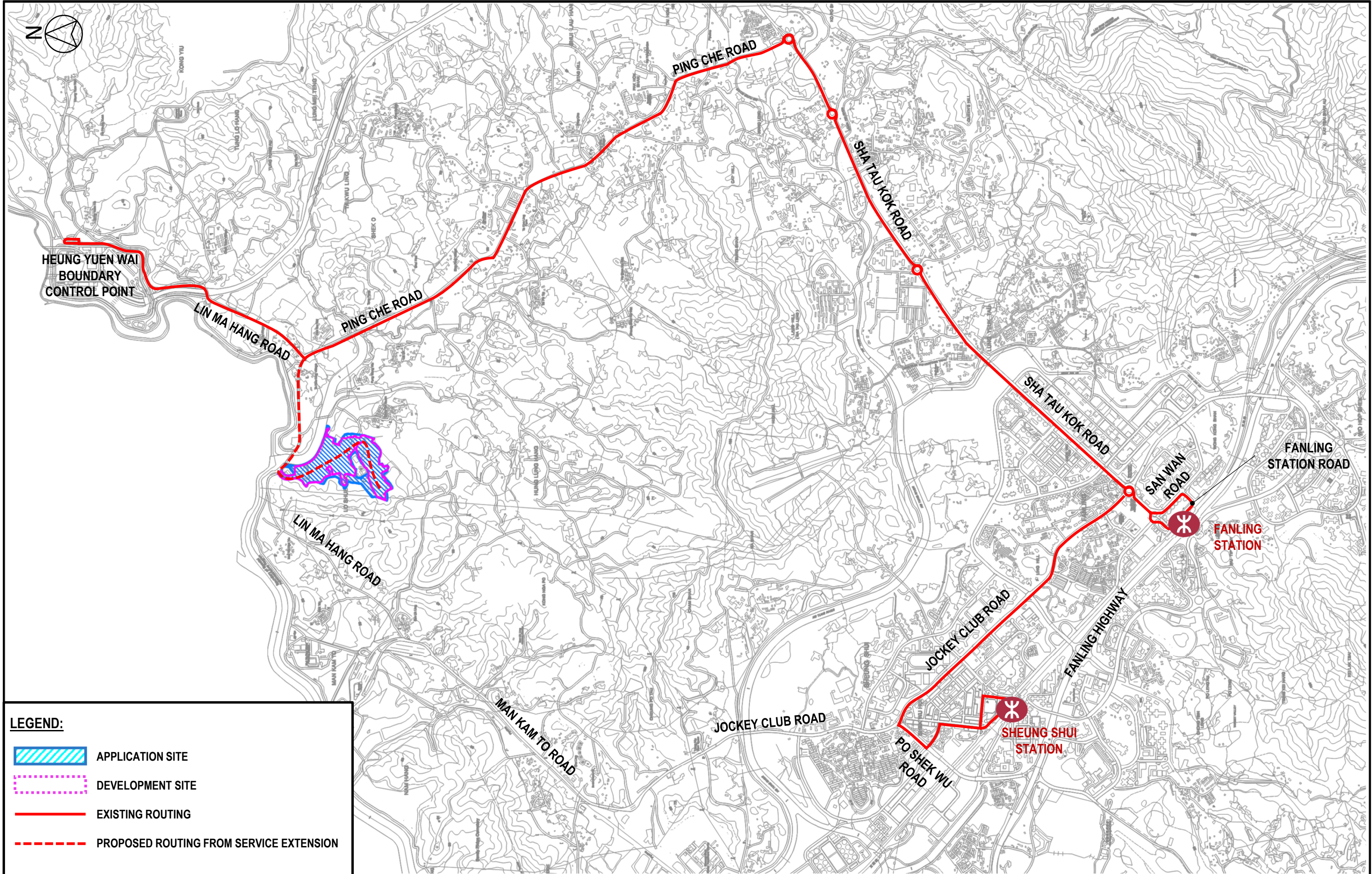

Job Title **APPLICATION FOR AMENDMENT OF PLAN UNDER SECTION 12A OF THE TOWN PLANNING ORDINANCE (CAP. 131) FOR PROPOSED INNOVATION AND TECHNOLOGY HUB AT VARIOUS LOTS IN D.D. 82 AND D.D. 86 AND ADJOINING GOVERNMENT LAND, MAN KAM TO, NEW TERRITORIES**

FIGURE 4.16

Date	Scale	Drawing Title
FEB 25	NTS	PROPOSED ROUTING OF KMB 79K FOR SERVICE EXTENSION TO THE APPLICATION SITE
Drawn	Job No.	
CKTY	287082-02	



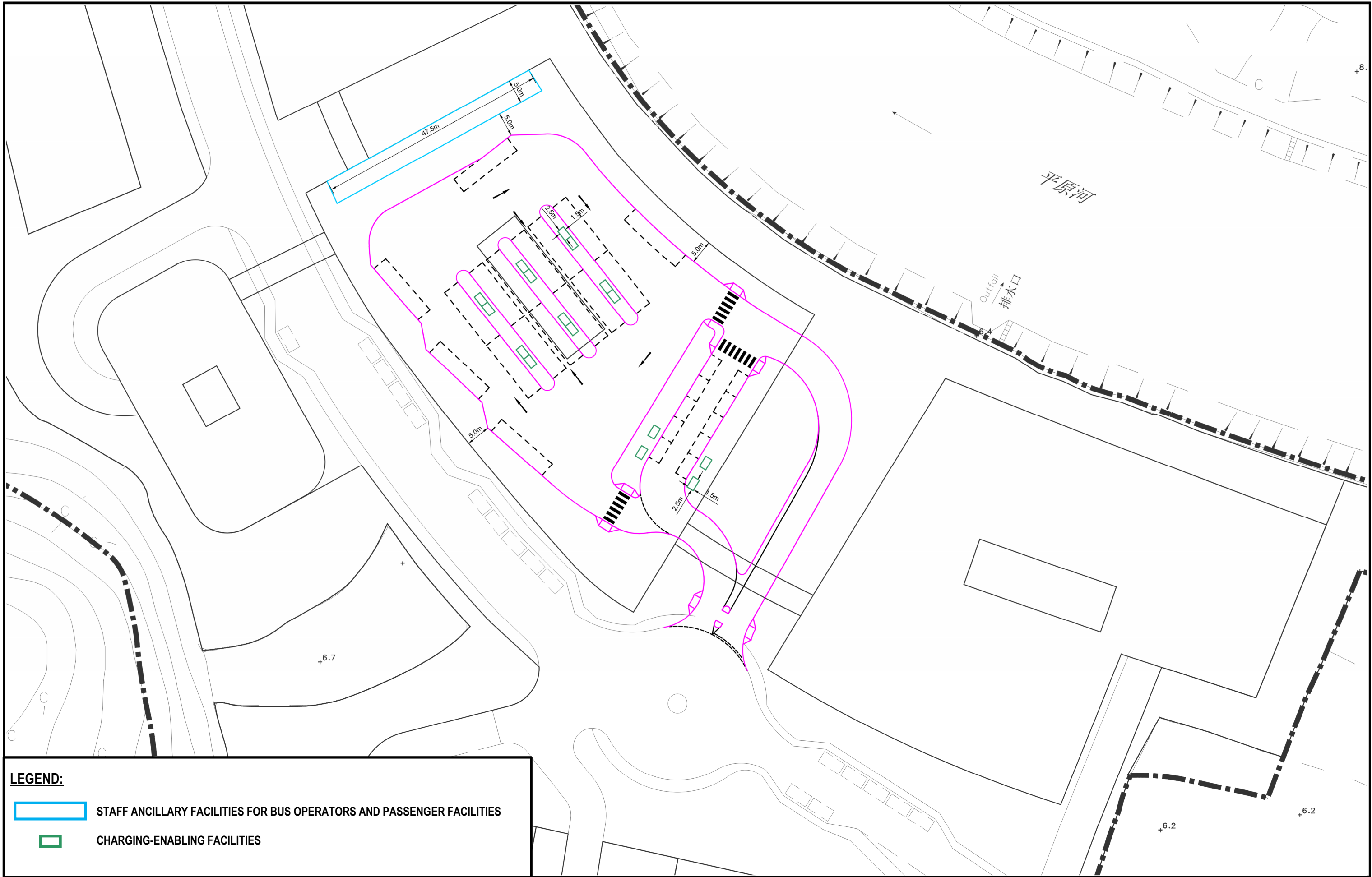

LEGEND:

- STAFF ANCILLARY FACILITIES FOR BUS OPERATORS AND PASSENGER FACILITIES
- CHARGING-ENABLING FACILITIES

Job Title **APPLICATION FOR AMENDMENT OF PLAN UNDER SECTION 12A OF THE TOWN PLANNING ORDINANCE (CAP. 131) FOR PROPOSED INNOVATION AND TECHNOLOGY HUB AT VARIOUS LOTS IN D.D. 82 AND D.D. 86 AND ADJOINING GOVERNMENT LAND, MAN KAM TO, NEW TERRITORIES**

FIGURE 4.17

Date	Scale
FEB 25	NTS
Drawn	Job No.
CKTY	287082-02

PROPOSED LAYOUT OF TERMINATING FACILITIES



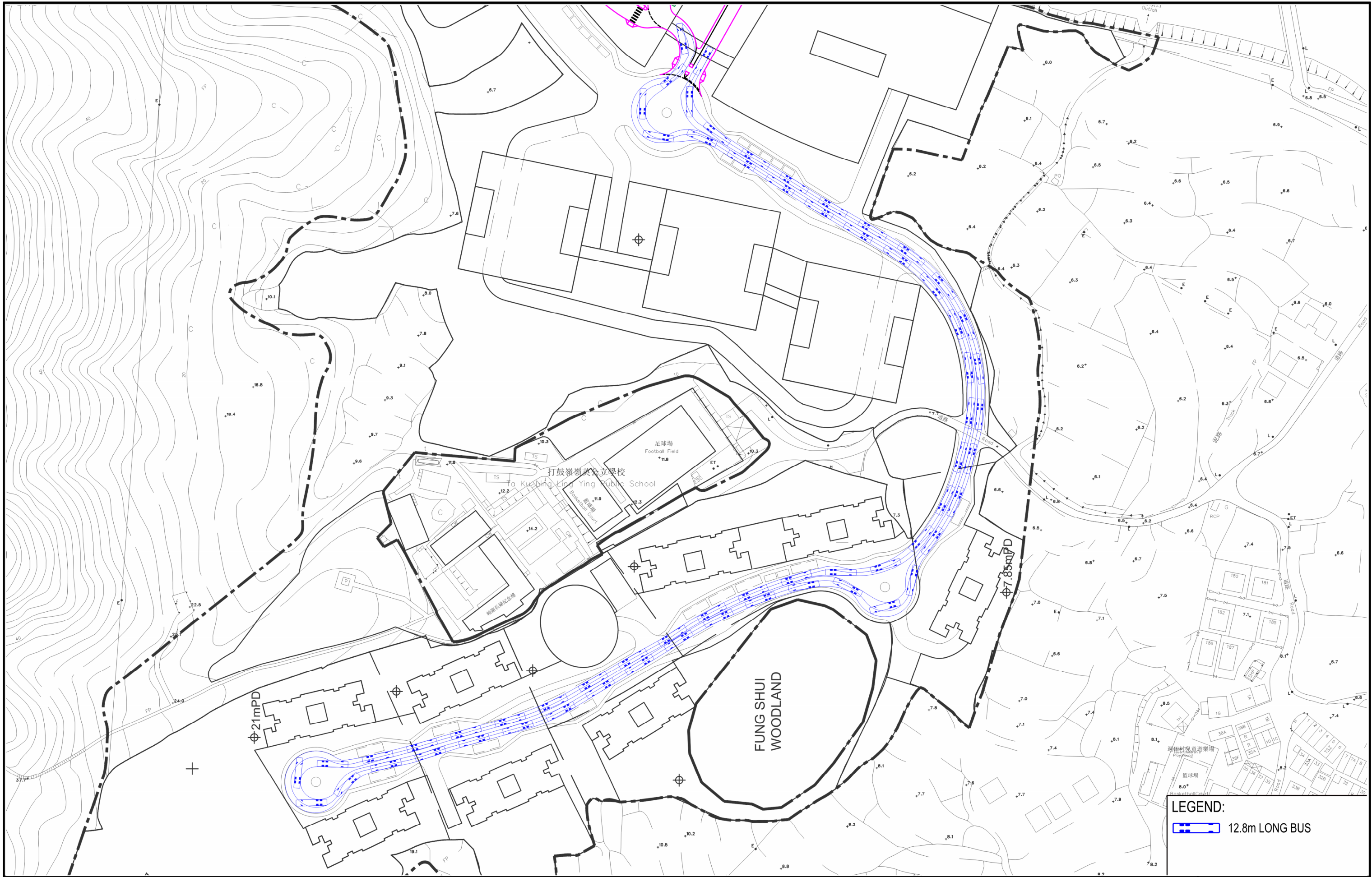

LEGEND:
 12.8m LONG BUS

Job Title **APPLICATION FOR AMENDMENT OF PLAN UNDER SECTION 12A OF THE TOWN PLANNING ORDINANCE (CAP. 131) FOR PROPOSED INNOVATION AND TECHNOLOGY HUB AT VARIOUS LOTS IN D.D. 82 AND D.D. 86 AND ADJOINING GOVERNMENT LAND, MAN KAM TO, NEW TERRITORIES**

FIGURE 4.18

Date	Scale	Drawing Title
FEB 25	NTS	SWEPT PATH ANALYSIS OF 12.8m LONG BUS BETWEEN THE PROPOSED TRANSPORT INTERCHANGE AND THE EN-ROUTE BUS STOPS
Drawn	Job No.	
CKTY	287082-02	

SWEPT PATH ANALYSIS OF 12.8m LONG BUS BETWEEN THE PROPOSED TRANSPORT INTERCHANGE AND THE EN-ROUTE BUS STOPS

ARUP

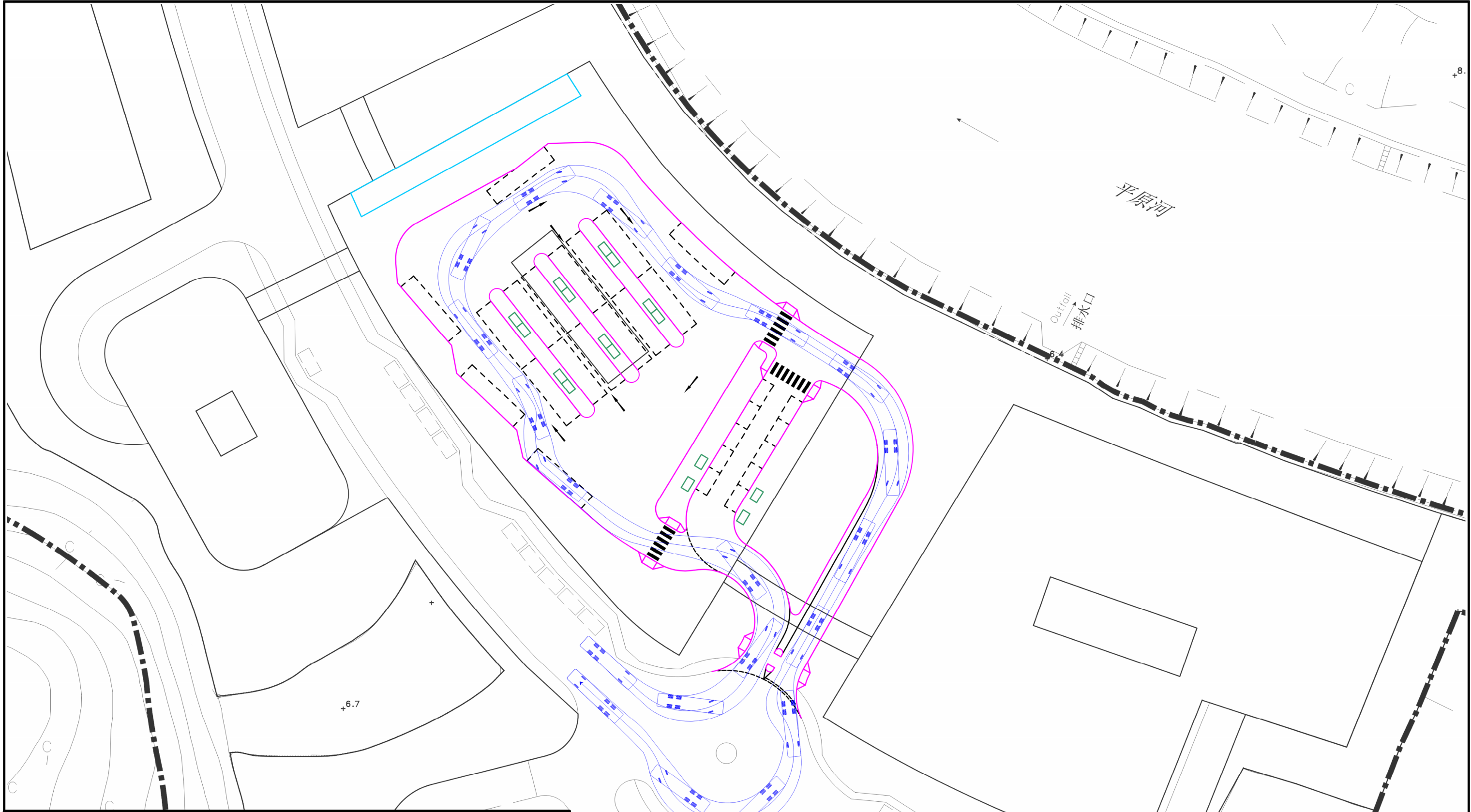

LEGEND:

- STAFF ANCILLARY FACILITIES FOR BUS OPERATORS AND PASSENGER FACILITIES
- CHARGING-ENABLING FACILITIES

LEGEND:

- 12.8m LONG BUS

Job Title: APPLICATION FOR AMENDMENT OF PLAN UNDER SECTION 12A OF THE TOWN PLANNING ORDINANCE (CAP. 131) FOR PROPOSED INNOVATION AND TECHNOLOGY HUB AT VARIOUS LOTS IN D.D. 82 AND D.D. 86 AND ADJOINING GOVERNMENT LAND, MAN KAM TO, NEW TERRITORIES

FIGURE 4.19

Date	Scale	Drawing Title
FEB 25	NTS	SWEPT PATH ANALYSIS OF 12.8m LONG BUS FROM INTERNAL DRIVEWAY APPROACHING BUS DROP-OFF BAY
Drawn	Job No.	
CKTY	287082-02	

SWEPT PATH ANALYSIS OF 12.8m LONG BUS FROM INTERNAL DRIVEWAY APPROACHING BUS DROP-OFF BAY



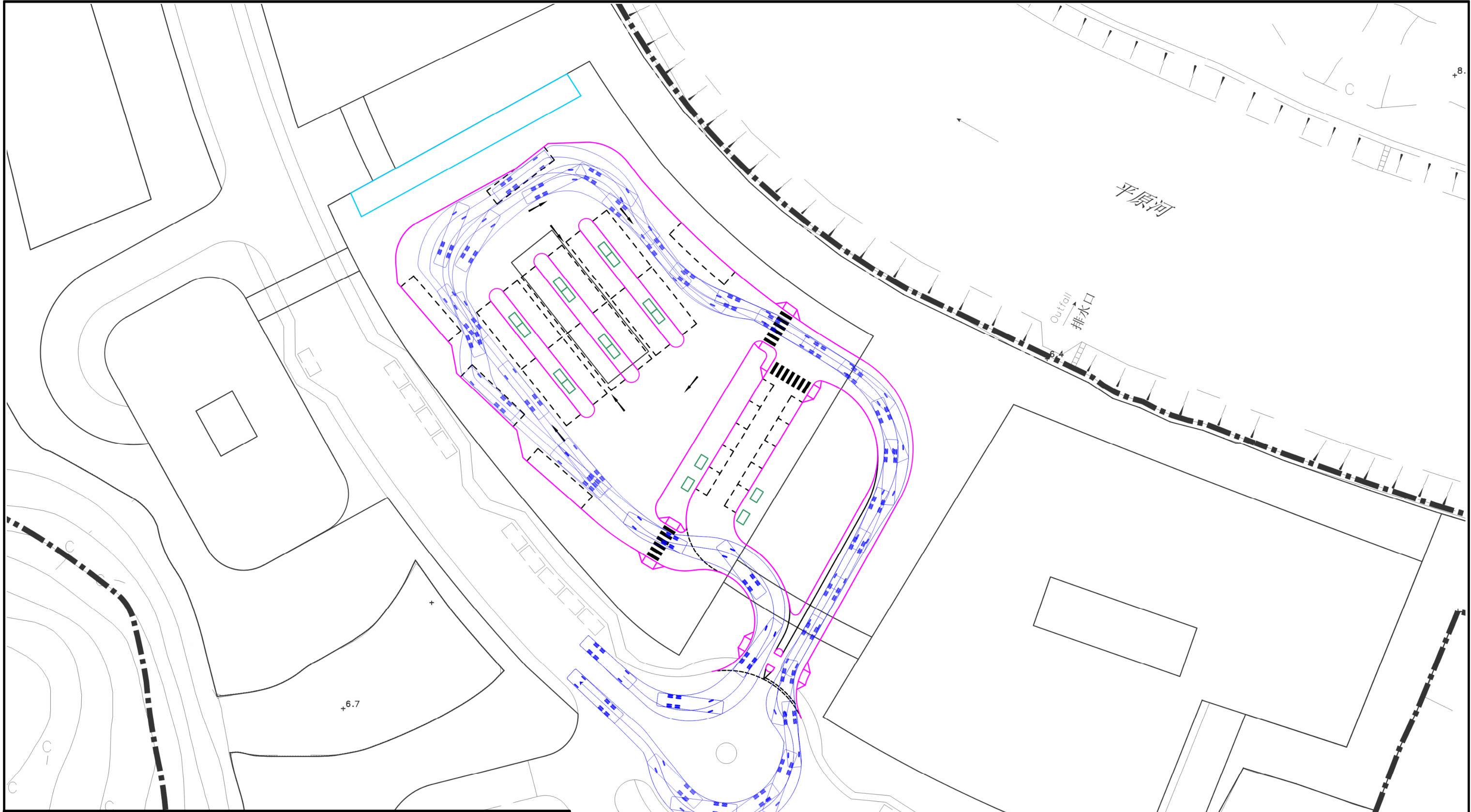

LEGEND:

- STAFF ANCILLARY FACILITIES FOR BUS OPERATORS AND PASSENGER FACILITIES
- CHARGING-ENABLING FACILITIES

LEGEND:

- 12.8m LONG BUS

Job Title **APPLICATION FOR AMENDMENT OF PLAN UNDER SECTION 12A OF THE TOWN PLANNING ORDINANCE (CAP. 131) FOR PROPOSED INNOVATION AND TECHNOLOGY HUB AT VARIOUS LOTS IN D.D. 82 AND D.D. 86 AND ADJOINING GOVERNMENT LAND, MAN KAM TO, NEW TERRITORIES**

FIGURE 4.20

Date	Scale
FEB 25	NTS
Drawn	Job No.
CKTY	287082-02

SWEPT PATH ANALYSIS OF 12.8m LONG BUS FROM INTERNAL DRIVEWAY APPROACHING BUS PICK-UP BAY 1, 3



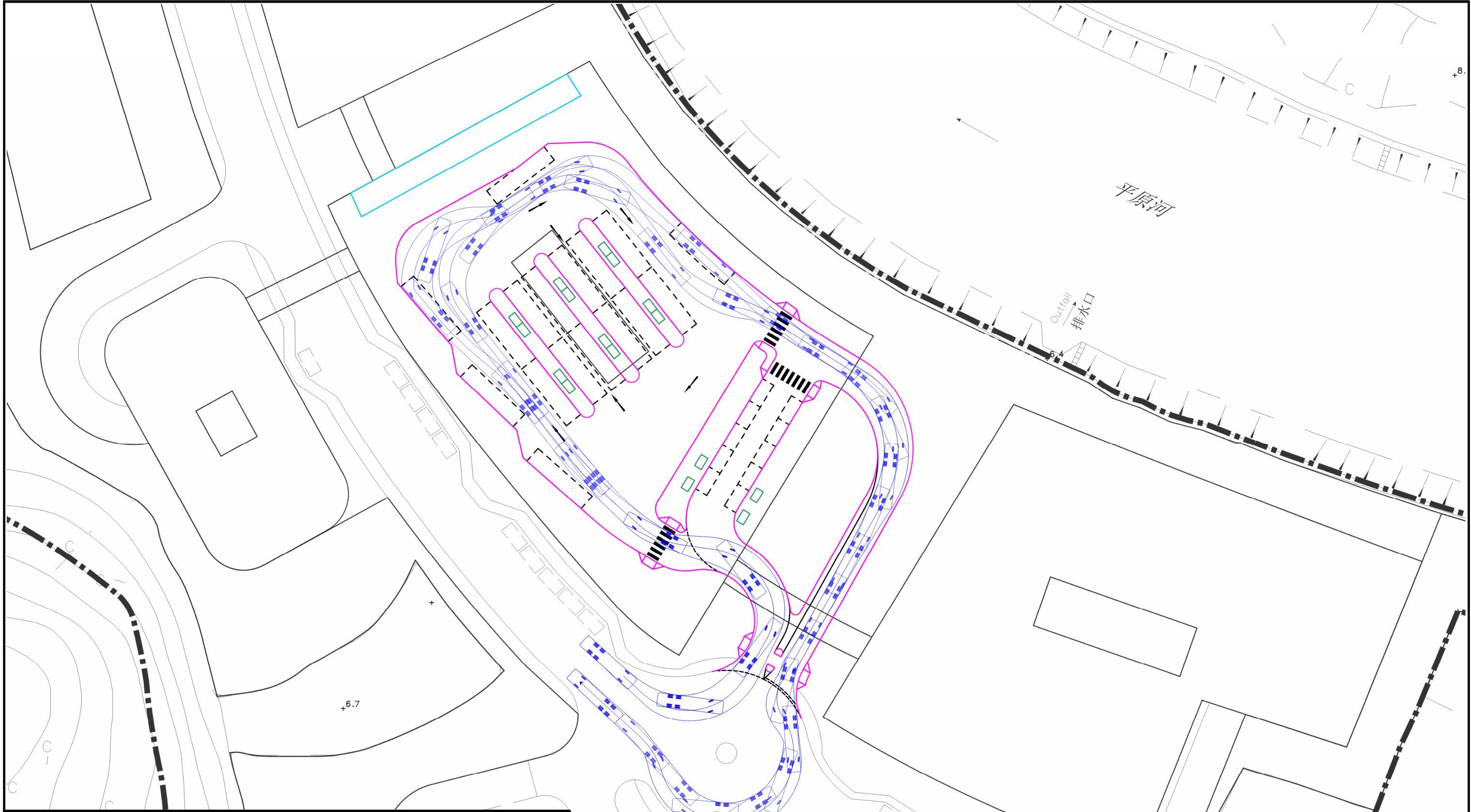

LEGEND:

- STAFF ANCILLARY FACILITIES FOR BUS OPERATORS AND PASSENGER FACILITIES
- CHARGING-ENABLING FACILITIES

LEGEND:

- 12.8m LONG BUS

Job Title **APPLICATION FOR AMENDMENT OF PLAN UNDER SECTION 12A OF THE TOWN PLANNING ORDINANCE (CAP. 131) FOR PROPOSED INNOVATION AND TECHNOLOGY HUB AT VARIOUS LOTS IN D.D. 82 AND D.D. 86 AND ADJOINING GOVERNMENT LAND, MAN KAM TO, NEW TERRITORIES**

FIGURE 4.21

Date	Scale
FEB 25	NTS
Drawn	Job No.
CKTY	287082-02

Drawing Title

SWEPT PATH ANALYSIS OF 12.8m LONG BUS FROM INTERNAL DRIVEWAY APPROACHING BUS PICK-UP BAY 2, 4



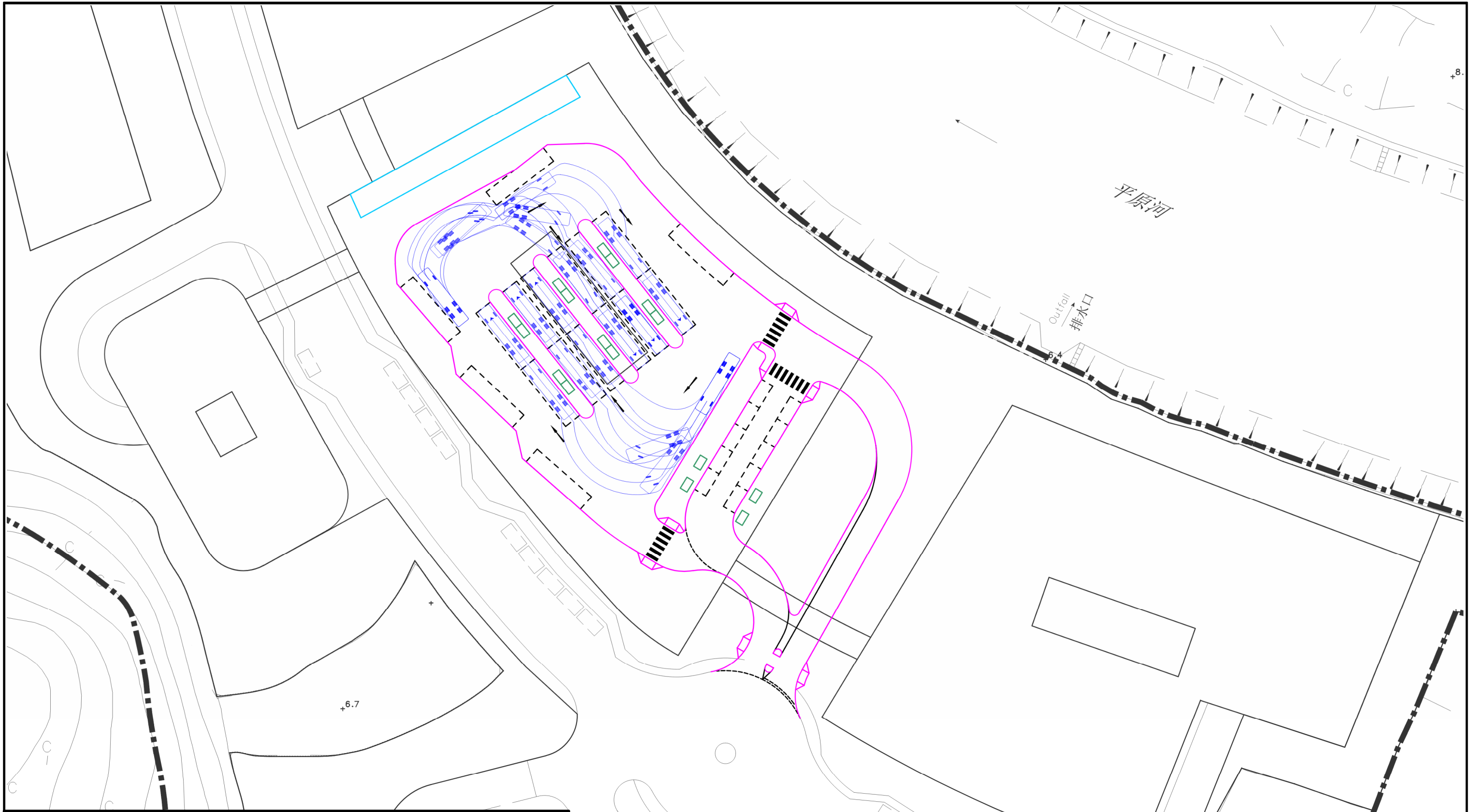

LEGEND:

- STAFF ANCILLARY FACILITIES FOR BUS OPERATORS AND PASSENGER FACILITIES
- CHARGING-ENABLING FACILITIES

LEGEND:

- 12.8m LONG BUS

Job Title: APPLICATION FOR AMENDMENT OF PLAN UNDER SECTION 12A OF THE TOWN PLANNING ORDINANCE (CAP. 131) FOR PROPOSED INNOVATION AND TECHNOLOGY HUB AT VARIOUS LOTS IN D.D. 82 AND D.D. 86 AND ADJOINING GOVERNMENT LAND, MAN KAM TO, NEW TERRITORIES

FIGURE 4.22

Date	Scale
FEB 25	NTS
Drawn	Job No.
CKTY	287082-02

SWEPT PATH ANALYSIS OF 12.8m LONG BUS APPROACHING BUS STACKING AREA



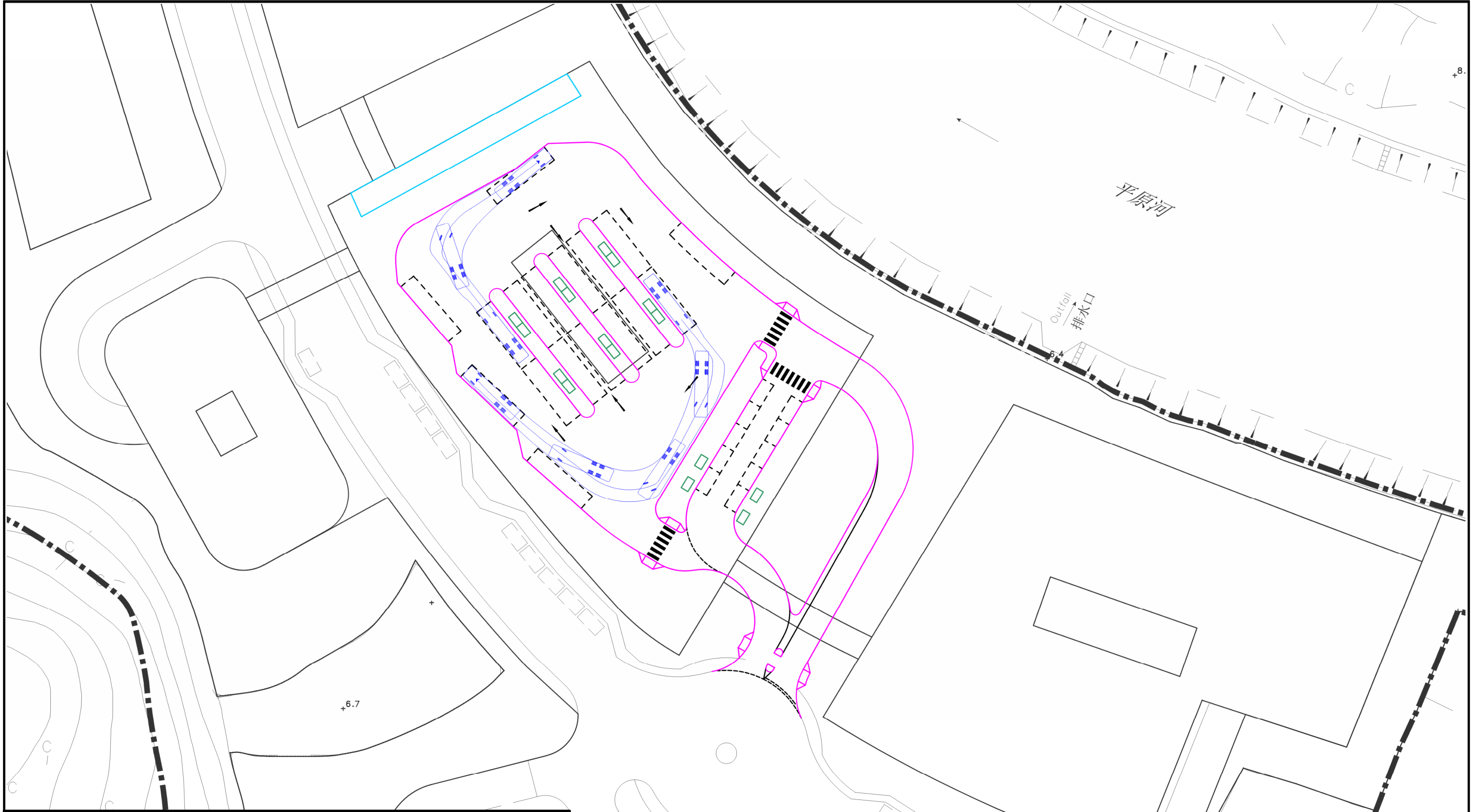

LEGEND:

- STAFF ANCILLARY FACILITIES FOR BUS OPERATORS AND PASSENGER FACILITIES
- CHARGING-ENABLING FACILITIES

LEGEND:

- 12.8m LONG BUS

Job Title **APPLICATION FOR AMENDMENT OF PLAN UNDER SECTION 12A OF THE TOWN PLANNING ORDINANCE (CAP. 131) FOR PROPOSED INNOVATION AND TECHNOLOGY HUB AT VARIOUS LOTS IN D.D. 82 AND D.D. 86 AND ADJOINING GOVERNMENT LAND, MAN KAM TO, NEW TERRITORIES**

FIGURE 4.23

Date	Scale	Drawing Title
FEB 25	NTS	SWEPT PATH ANALYSIS OF 12.8m LONG BUS FROM BUS STACKING AREA APPROACHING BUS PICK-UP BAY 1, 3
Drawn	Job No.	
CKTY	287082-02	

SWEPT PATH ANALYSIS OF 12.8m LONG BUS FROM BUS STACKING AREA APPROACHING BUS PICK-UP BAY 1, 3



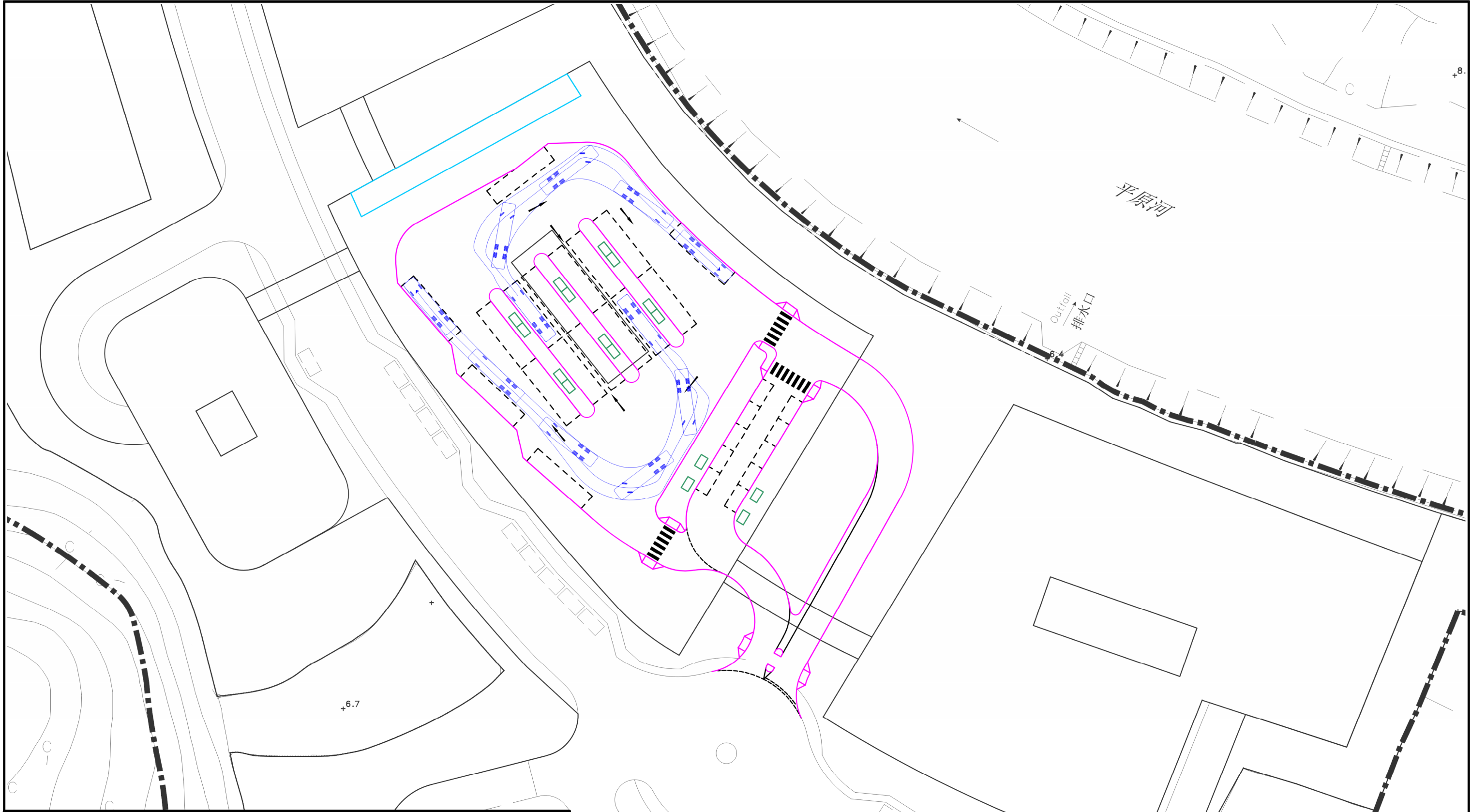

LEGEND:

- STAFF ANCILLARY FACILITIES FOR BUS OPERATORS AND PASSENGER FACILITIES
- CHARGING-ENABLING FACILITIES

LEGEND:

- 12.8m LONG BUS

Job Title **APPLICATION FOR AMENDMENT OF PLAN UNDER SECTION 12A OF THE TOWN PLANNING ORDINANCE (CAP. 131) FOR PROPOSED INNOVATION AND TECHNOLOGY HUB AT VARIOUS LOTS IN D.D. 82 AND D.D. 86 AND ADJOINING GOVERNMENT LAND, MAN KAM TO, NEW TERRITORIES**

FIGURE 4.24

Date	Scale
FEB 25	NTS
Drawn	Job No.
CKTY	287082-02

Drawing Title

SWEPT PATH ANALYSIS OF 12.8m LONG BUS FROM BUS STACKING AREA APPROACHING BUS PICK-UP BAY 2, 4



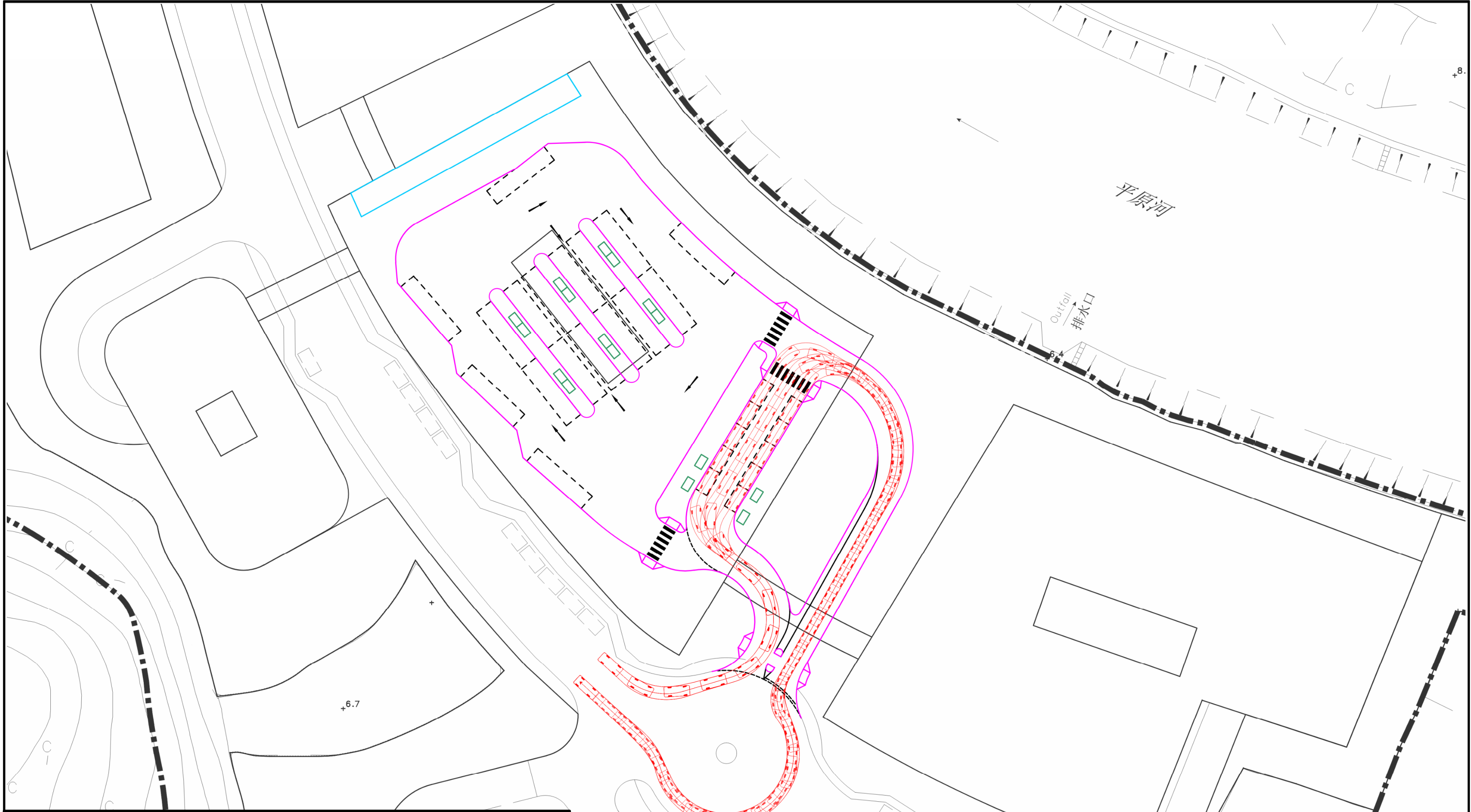

LEGEND:

- STAFF ANCILLARY FACILITIES FOR BUS OPERATORS AND PASSENGER FACILITIES
- CHARGING-ENABLING FACILITIES

LEGEND:

- 5m LONG TAXI

Job Title **APPLICATION FOR AMENDMENT OF PLAN UNDER SECTION 12A OF THE TOWN PLANNING ORDINANCE (CAP. 131) FOR PROPOSED INNOVATION AND TECHNOLOGY HUB AT VARIOUS LOTS IN D.D. 82 AND D.D. 86 AND ADJOINING GOVERNMENT LAND, MAN KAM TO, NEW TERRITORIES**

FIGURE 4.25

Date **FEB 25**
 Scale **NTS**
 Drawn **CKTY**
 Job No. **287082-02**

Drawing Title **SWEPT PATH ANALYSIS OF 5m LONG TAXI ON TAXI STANDS**



Appendix A

Existing Road Improvement Works under Construction

Widening Part of Lin Ma Hang Road (Man Kam To Road to Ping Yuen River) – under CEDD project number 5758CL

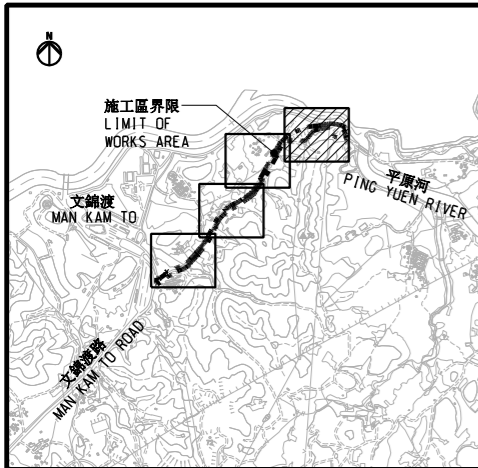

位置圖
LOCATION PLAN
比例 SCALE A1 1:20000

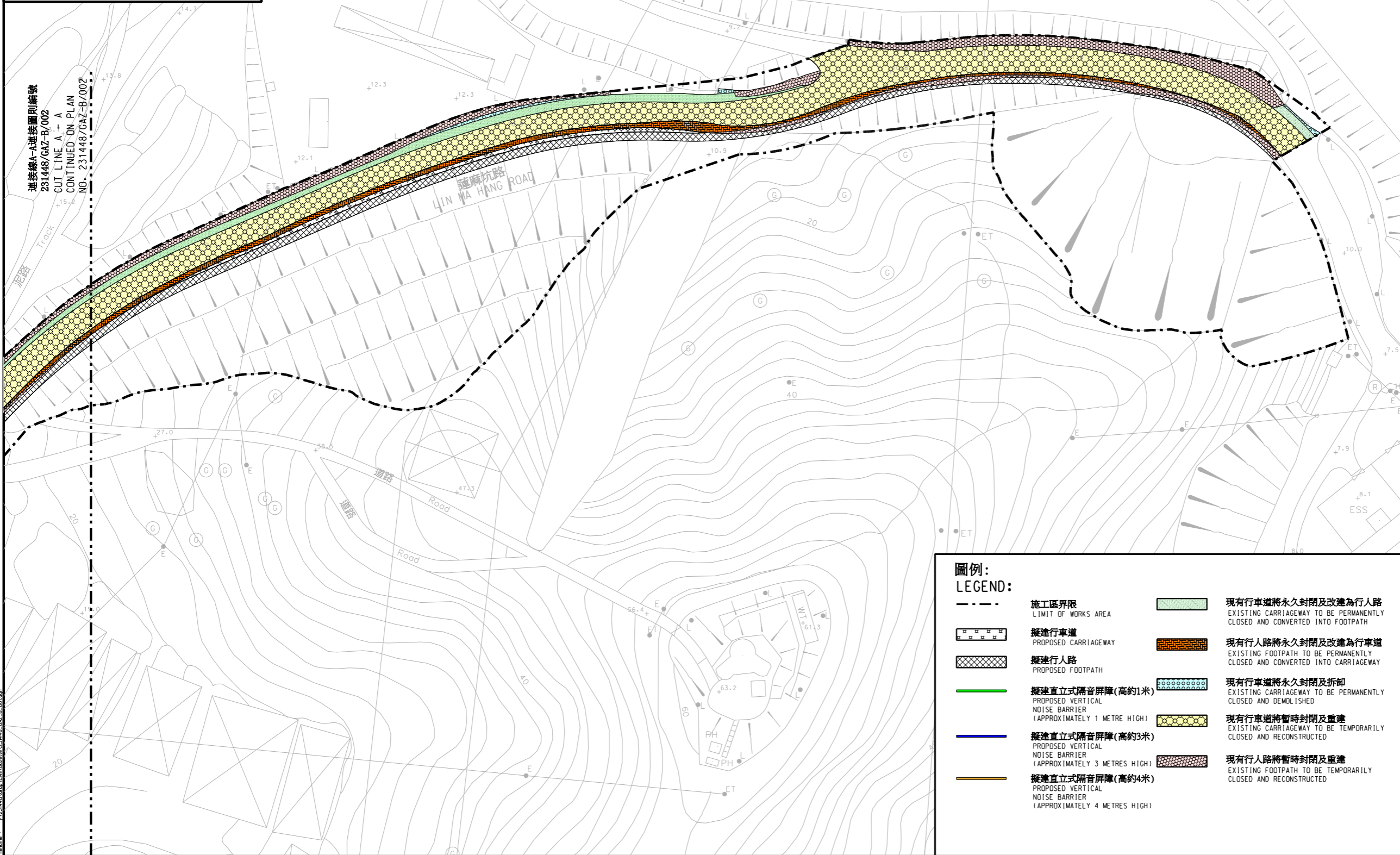

連接線A-A連接圖則編號
231448/GAZ-B/002
CUT LINE A - A
CONTINUED ON PLAN
NO. 231448/GAZ-B/002

- 註
NOTE:
- 除在其他方面指定外，全部以米為量度單位。
ALL DIMENSIONS ARE IN METRES UNLESS OTHERWISE STATED.
 - 所有水平均為約數，以米為單位，並在香港水平基準以上(+)或以下(-)。
ALL LEVELS ARE APPROXIMATE VALUES AND IN METRES ABOVE (+) OR BELOW (-) HONG KONG PRINCIPAL DATUM.
 - 如有需要，施工區界限內現有行車道及行人路或會分階段暫時封閉。
SECTIONS OF THE EXISTING CARRIAGEWAYS AND FOOTPATHS WITHIN THE LIMIT OF WORKS AREA MAY BE TEMPORARILY CLOSED IN PHASES AS AND WHEN REQUIRED.

工程名稱 PROJECT TITLE
工務計劃項目第5758CL號
沙嶺墳場興建骨灰龕、火葬場及有關設施
的土地平整及相關基建工程
- 擴闊部份蓮麻坑路
PWP ITEM NO. 5758CL
SITE FORMATION AND ASSOCIATED
INFRASTRUCTURAL WORKS FOR DEVELOPMENT
OF COLUMBARIUM, CREMATORIUM AND RELATED
FACILITIES AT SANDY RIDGE CEMETERY
- WIDENING PART OF LIN MA HANG ROAD

圖則名稱 PLAN TITLE
根據《道路(工程、使用及補償)條例》(第370章)
而在憲報公布之圖則
PLAN FOR GAZETTING UNDER
ROADS (WORKS, USE AND COMPENSATION)
ORDINANCE (CHAPTER 370)

圖則編號 PLAN NO. 231448/GAZ-B/001
比例 SCALE 1:500 @ A1

辦事處 OFFICE
土木工程處 土地工程處
LAND WORKS DIVISION
CIVIL ENGINEERING OFFICE



圖例:
LEGEND:

---	施工區界限 LIMIT OF WORKS AREA	[Green hatched box]	現有行車道將永久封閉及改建為行人路 EXISTING CARRIAGEWAY TO BE PERMANENTLY CLOSED AND CONVERTED INTO FOOTPATH
[Blue hatched box]	擬建行車道 PROPOSED CARRIAGEWAY	[Orange hatched box]	現有行人路將永久封閉及改建為行車道 EXISTING FOOTPATH TO BE PERMANENTLY CLOSED AND CONVERTED INTO CARRIAGEWAY
[Cross-hatched box]	擬建行人路 PROPOSED FOOTPATH	[Blue dashed line]	現有行車道將永久封閉及拆卸 EXISTING CARRIAGEWAY TO BE PERMANENTLY CLOSED AND DEMOLISHED
[Green solid line]	擬建直立式隔音屏障(高約1米) PROPOSED VERTICAL NOISE BARRIER (APPROXIMATELY 1 METRE HIGH)	[Yellow hatched box]	現有行車道將暫時封閉及重建 EXISTING CARRIAGEWAY TO BE TEMPORARILY CLOSED AND RECONSTRUCTED
[Blue solid line]	擬建直立式隔音屏障(高約3米) PROPOSED VERTICAL NOISE BARRIER (APPROXIMATELY 3 METRES HIGH)	[Brown hatched box]	現有行人路將暫時封閉及重建 EXISTING FOOTPATH TO BE TEMPORARILY CLOSED AND RECONSTRUCTED
[Yellow solid line]	擬建直立式隔音屏障(高約4米) PROPOSED VERTICAL NOISE BARRIER (APPROXIMATELY 4 METRES HIGH)		

Printed by: 2/12/2015
File No: 231448/GAZ-B/001

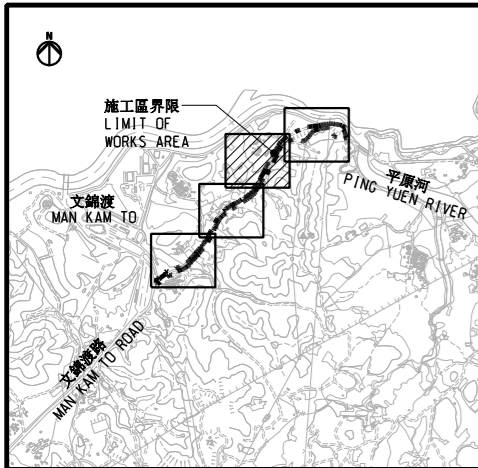

位置圖
LOCATION PLAN
比例 SCALE A1 1:20000

圖例:
LEGEND:

	施工區界限 LIMIT OF WORKS AREA		現有行車道將永久封閉及改建為行人路 EXISTING CARRIAGEWAY TO BE PERMANENTLY CLOSED AND CONVERTED INTO FOOTPATH
	擬建行車道 PROPOSED CARRIAGEWAY		現有行人路將永久封閉及改建為行車道 EXISTING FOOTPATH TO BE PERMANENTLY CLOSED AND CONVERTED INTO CARRIAGEWAY
	擬建行人路 PROPOSED FOOTPATH		現有行車道將永久封閉及拆卸 EXISTING CARRIAGEWAY TO BE PERMANENTLY CLOSED AND DEMOLISHED
	擬建直立式隔音屏障(高約1米) PROPOSED VERTICAL NOISE BARRIER (APPROXIMATELY 1 METRE HIGH)		現有行車道將暫時封閉及重建 EXISTING CARRIAGEWAY TO BE TEMPORARILY CLOSED AND RECONSTRUCTED
	擬建直立式隔音屏障(高約3米) PROPOSED VERTICAL NOISE BARRIER (APPROXIMATELY 3 METRES HIGH)		現有行人路將暫時封閉及重建 EXISTING FOOTPATH TO BE TEMPORARILY CLOSED AND RECONSTRUCTED
	擬建直立式隔音屏障(高約4米) PROPOSED VERTICAL NOISE BARRIER (APPROXIMATELY 4 METRES HIGH)		

Widening Part of Lin Ma Hang Road (Man Kam To Road to Ping Yuen River) – under CEDD project number 5758CL

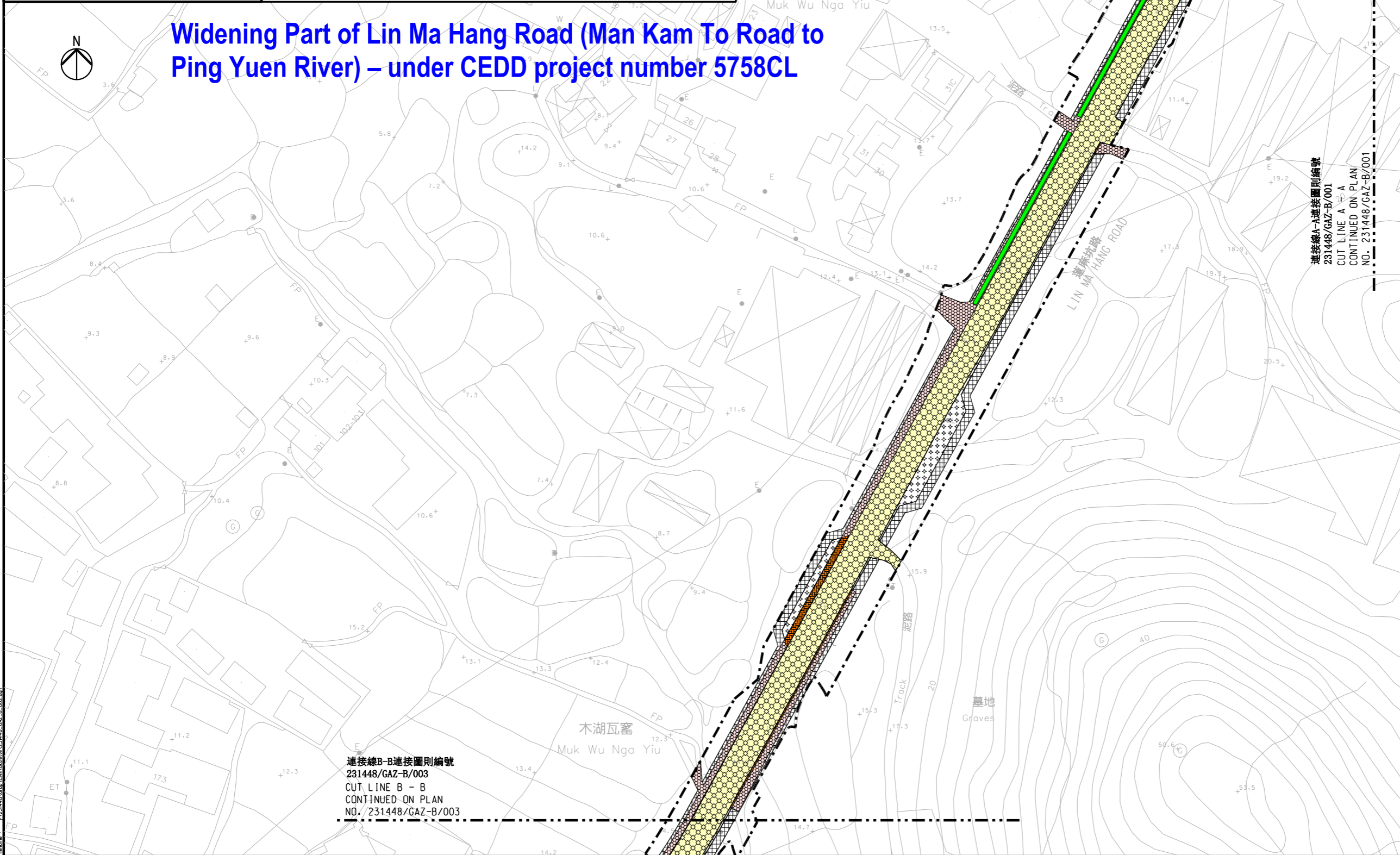

連接線B-B連接圖則編號
231448/GAZ-B/003
CUT LINE B - B
CONTINUED ON PLAN
NO. 231448/GAZ-B/003

連接線A-A連接圖則編號
231448/GAZ-B/001
CUT LINE A - A
CONTINUED ON PLAN
NO. 231448/GAZ-B/001

註
NOTE:

- 除在其他方面指定外，全部以米為量度單位。
ALL DIMENSIONS ARE IN METRES UNLESS OTHERWISE STATED.
- 所有水平均為約數，以米為單位，並在香港水平基準以上(+)或以下(-)。
ALL LEVELS ARE APPROXIMATE VALUES AND IN METRES ABOVE (+) OR BELOW (-) HONG KONG PRINCIPAL DATUM.
- 如有需要，施工區界限內現有行車道及行人路或會分階段暫時封閉。
SECTIONS OF THE EXISTING CARRIAGEWAYS AND FOOTPATHS WITHIN THE LIMIT OF WORKS AREA MAY BE TEMPORARILY CLOSED IN PHASES AS AND WHEN REQUIRED.

工程名稱 PROJECT TITLE 工務計劃項目第5758CL號 沙墳墳場興建骨灰龕、火葬場及有關設施 的土地平整及相關基建工程 - 擴闊部份蓮麻坑路	
PWP ITEM NO. 5758CL SITE FORMATION AND ASSOCIATED INFRASTRUCTURAL WORKS FOR DEVELOPMENT OF COLUMBARIUM, CREMATORIUM AND RELATED FACILITIES AT SANDY RIDGE CEMETERY - WIDENING PART OF LIN MA HANG ROAD	
圖則名稱 PLAN TITLE 根據《道路(工程、使用及補償)條例》(第370章) 而在憲報公布之圖則 PLAN FOR GAZETTING UNDER ROADS(WORKS, USE AND COMPENSATION) ORDINANCE (CHAPTER 370)	
圖則編號 PLAN NO.	比例 SCALE
231448/GAZ-B/002	1:500 @ A1
辦事處 OFFICE 土木工程處 土地工程部 LAND WORKS DIVISION CIVIL ENGINEERING OFFICE	
土木工程拓展署 CIVIL ENGINEERING AND DEVELOPMENT DEPARTMENT	

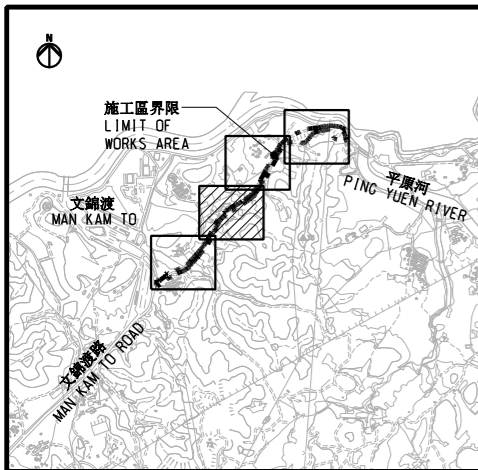

位置圖
LOCATION PLAN
比例 SCALE A1 1:20000

圖例:
LEGEND:

	施工區界限 LIMIT OF WORKS AREA		現有行車道將永久封閉及改建為行人路 EXISTING CARRIAGEWAY TO BE PERMANENTLY CLOSED AND CONVERTED INTO FOOTPATH
	擬建行車道 PROPOSED CARRIAGEWAY		現有行人路將永久封閉及改建為行車道 EXISTING FOOTPATH TO BE PERMANENTLY CLOSED AND CONVERTED INTO CARRIAGEWAY
	擬建行人路 PROPOSED FOOTPATH		現有行車道將永久封閉及拆卸 EXISTING CARRIAGEWAY TO BE PERMANENTLY CLOSED AND DEMOLISHED
	擬建直立式隔音屏障(高約1米) PROPOSED VERTICAL NOISE BARRIER (APPROXIMATELY 1 METRE HIGH)		現有行車道將暫時封閉及重建 EXISTING CARRIAGEWAY TO BE TEMPORARILY CLOSED AND RECONSTRUCTED
	擬建直立式隔音屏障(高約3米) PROPOSED VERTICAL NOISE BARRIER (APPROXIMATELY 3 METRES HIGH)		現有行人路將暫時封閉及重建 EXISTING FOOTPATH TO BE TEMPORARILY CLOSED AND RECONSTRUCTED
	擬建直立式隔音屏障(高約4米) PROPOSED VERTICAL NOISE BARRIER (APPROXIMATELY 4 METRES HIGH)		

Widening Part of Lin Ma Hang Road (Man Kam To Road to Ping Yuen River) – under CEDD project number 5758CL

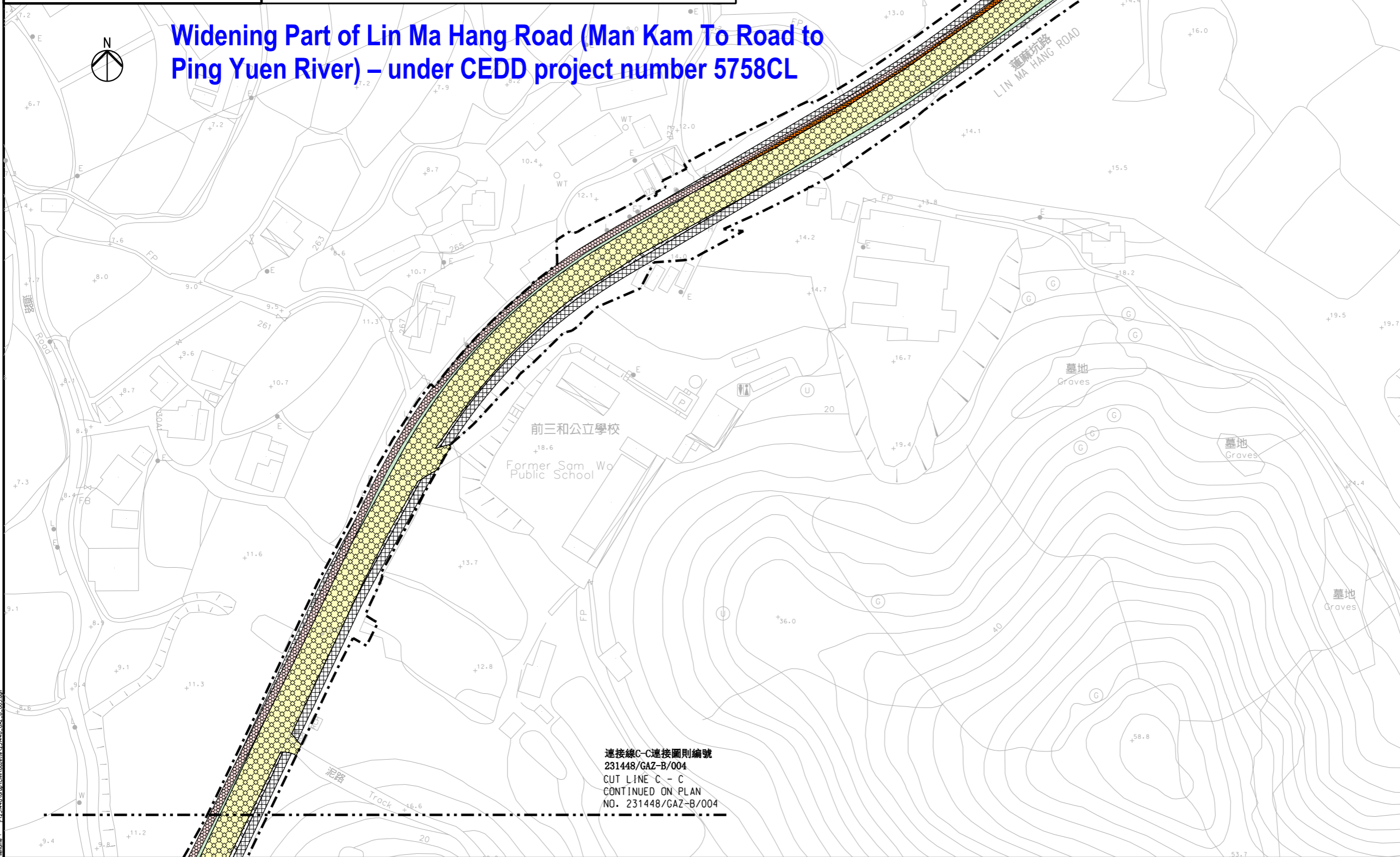

註
NOTE:

- 除在其他方面指定外，全部以米為量度單位。
ALL DIMENSIONS ARE IN METRES UNLESS OTHERWISE STATED.
- 所有水平均為約數，以米為單位，並在香港水平基準以上(+)或以下(-)。
ALL LEVELS ARE APPROXIMATE VALUES AND IN METRES ABOVE (+) OR BELOW (-) HONG KONG PRINCIPAL DATUM.
- 如有需要，施工區界限內現有行車道及行人路或會分階段暫時封閉。
SECTIONS OF THE EXISTING CARRIAGEWAYS AND FOOTPATHS WITHIN THE LIMIT OF WORKS AREA MAY BE TEMPORARILY CLOSED IN PHASES AS AND WHEN REQUIRED.

工程名稱 PROJECT TITLE 工務計劃項目第5758CL號 沙墳墳場興建骨灰龕、火葬場及有關設施 的土地平整及相關基建工程 - 擴闊部份蓮麻坑路	
PWP ITEM NO. 5758CL SITE FORMATION AND ASSOCIATED INFRASTRUCTURAL WORKS FOR DEVELOPMENT OF COLUMBARIUM, CREMATORIUM AND RELATED FACILITIES AT SANDY RIDGE CEMETERY - WIDENING PART OF LIN MA HANG ROAD	
圖則名稱 PLAN TITLE 根據《道路(工程、使用及補償)條例》(第370章) 而在憲報公布之圖則 PLAN FOR GAZETTING UNDER ROADS(WORKS, USE AND COMPENSATION) ORDINANCE (CHAPTER 370)	
圖則編號 PLAN NO.	比例 SCALE
231448/GAZ-B/003	1:500 @ A1
辦事處 OFFICE 土木工程處 土地工程處 LAND WORKS DIVISION CIVIL ENGINEERING OFFICE	
土木工程拓展署 CIVIL ENGINEERING AND DEVELOPMENT DEPARTMENT	

Prepared by: 2/12/2015
 File name: I:\231448\Map\Gazette\231448_GAZ_B_003.dwg

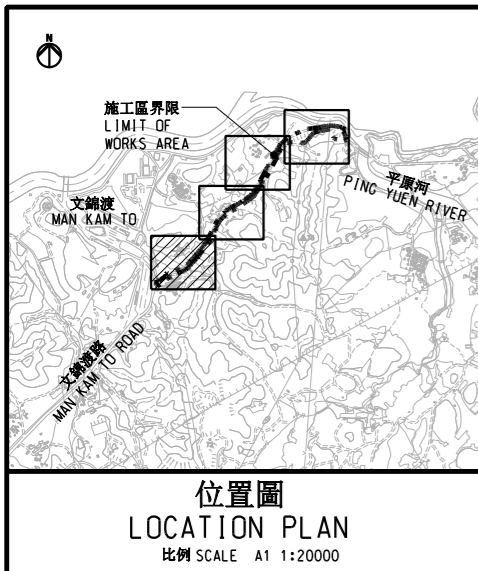

圖例:
LEGEND:

	施工區界限 LIMIT OF WORKS AREA		現有行車道將永久封閉及改建為行人路 EXISTING CARRIAGEWAY TO BE PERMANENTLY CLOSED AND CONVERTED INTO FOOTPATH
	擬建行車道 PROPOSED CARRIAGEWAY		現有行人路將永久封閉及改建為行車道 EXISTING FOOTPATH TO BE PERMANENTLY CLOSED AND CONVERTED INTO CARRIAGEWAY
	擬建行人路 PROPOSED FOOTPATH		現有行車道將永久封閉及拆卸 EXISTING CARRIAGEWAY TO BE PERMANENTLY CLOSED AND DEMOLISHED
	擬建直立式隔音屏障(高約1米) PROPOSED VERTICAL NOISE BARRIER (APPROXIMATELY 1 METRE HIGH)		現有行車道將暫時封閉及重建 EXISTING CARRIAGEWAY TO BE TEMPORARILY CLOSED AND RECONSTRUCTED
	擬建直立式隔音屏障(高約3米) PROPOSED VERTICAL NOISE BARRIER (APPROXIMATELY 3 METRES HIGH)		現有行人路將暫時封閉及重建 EXISTING FOOTPATH TO BE TEMPORARILY CLOSED AND RECONSTRUCTED
	擬建直立式隔音屏障(高約4米) PROPOSED VERTICAL NOISE BARRIER (APPROXIMATELY 4 METRES HIGH)		

連接線C-C連接圖則編號
231448/GAZ-B/003
CUT LINE C - C
CONTINUED ON PLAN
NO. 231448/GAZ-B/003

Widening Part of Lin Ma Hang Road (Man Kam To Road to Ping Yuen River) – under CEDD project number 5758CL

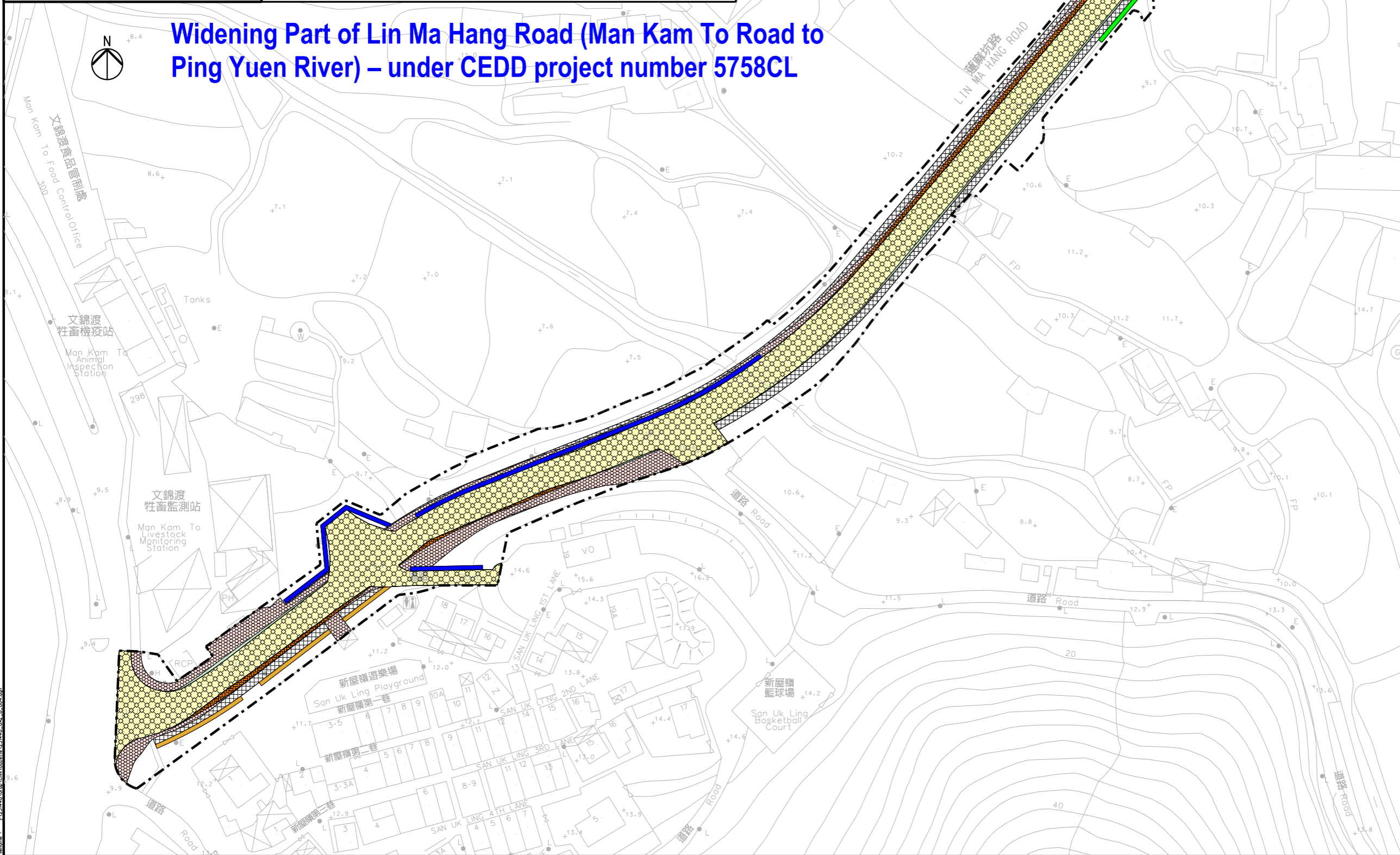

註
NOTE:

- 除在其他方面指定外，全部以米為量度單位。
ALL DIMENSIONS ARE IN METRES UNLESS OTHERWISE STATED.
- 所有水平均為約數，以米為單位，並在香港水平基準以上(+)或以下(-)。
ALL LEVELS ARE APPROXIMATE VALUES AND IN METRES ABOVE (+) OR BELOW (-) HONG KONG PRINCIPAL DATUM.
- 如有需要，施工區界限內現有行車道及行人路或會分階段暫時封閉。
SECTIONS OF THE EXISTING CARRIAGEWAYS AND FOOTPATHS WITHIN THE LIMIT OF WORKS AREA MAY BE TEMPORARILY CLOSED IN PHASES AS AND WHEN REQUIRED.

工程名稱 PROJECT TITLE
工務計劃項目第5758CL號
沙嶺墳場興建骨灰龕、火葬場及有關設施
的土地平整及相關基建工程
- 擴闊部份蓮麻坑路

PWP ITEM NO. 5758CL
SITE FORMATION AND ASSOCIATED
INFRASTRUCTURAL WORKS FOR DEVELOPMENT
OF COLUMBARIUM, CREMATORIUM AND RELATED
FACILITIES AT SANDY RIDGE CEMETERY
- WIDENING PART OF LIN MA HANG ROAD

圖則名稱 PLAN TITLE
根據《道路(工程、使用及補償)條例》(第370章)
而在憲報公布之圖則

PLAN FOR GAZETTING UNDER
ROADS(WORKS, USE AND COMPENSATION)
ORDINANCE (CHAPTER 370)

圖則編號 PLAN NO. 231448/GAZ-B/004
比例 SCALE 1:500 @ A1

辦事處 OFFICE
土木工程處 土地工程處
LAND WORKS DIVISION
CIVIL ENGINEERING OFFICE



Prepared by: 2/12/2015
 Drawn by: 1/2/2016
 Checked by: 2/12/2015

Widening of western section of Lin Ma Hang Road between Ping Yuen River and Ping Che Road – under HyD PWP Item 863TH

附件一
(兩張中的第一張)

ENCLOSURE 1
(SHEET 1 OF 2)

0 mm

100

200



索引圖 KEY PLAN
比例 SCALE 1:10000

平原河抽水站
RIVER GANGES
PUMPING STATION

現有行車橋
EXISTING VEHICULAR BRIDGE

蓮麻坑路
LIN MA HANG ROAD

平原河
PING YUEN RIVER

打鼓嶺村
TA KWU LING
VILLAGE

簡頭圍
KAN TAU WAI

坪輦路
PING CHE ROAD

圖例 LEGEND:

- 施工區界限
WORKS BOUNDARY
- 擬重建/擴闊的道路
PROPOSED RECONSTRUCTION /
WIDENING OF ROAD
- 擬重建的行人路
PROPOSED RECONSTRUCTION
OF FOOTPATH
- 擬建行車橋
PROPOSED CONSTRUCTION OF
VEHICLE BRIDGE
- 擬建斜坡
PROPOSED SLOPE
- 擋土牆
RETAINING WALL

0 100 200 m
1:4 000 SCALE BAR

圖則名稱 plan title

工務計劃項目第6863TH號蓮麻坑路西段(平原河至坪輦路)擴闊工程 - 平面圖

PWP ITEM NO. 6863TH WIDENING OF WESTERN SECTION OF LIN MA HANG ROAD
BETWEEN PING YUEN RIVER AND PING CHE ROAD - LAYOUT PLAN

圖則編號 plan no.

HMW6863TH-SK0007

比例 scale

1:4000 或圖示
Or As Shown

© 版權所有 COPYRIGHT RESERVED



HIGHWAYS
DEPARTMENT
HONG KONG
路
政
署

Widening of western section of Lin Ma Hang Road between Ping Yuen River and Ping Che Road – under HyD PWP Item 863TH

附件一
(兩張中的第二張)

ENCLOSURE 1
(SHEET 2 OF 2)

0 mm

100

200

現有單線行車道
供作西行行車道
EXISTING SINGLE
LANE CARRIAGEWAY
FOR FUTURE
WESTBOUND TRAFFIC

擬建單線行車道
供作東行行車道
PROPOSED SINGLE
LANE CARRIAGEWAY
FOR FUTURE
EASTBOUND TRAFFIC

擬建緊急/公用設施通道
PROPOSED EMERGENCY/
UTILITIES ACCESS

現有行人路
EXISTING
FOOTPATH

擬建主圍網
PROPOSED PRIMARY
BOUNDARY
FENCE

現有行車橋
EXISTING
VEHICULAR
BRIDGE

擬建防欄
PROPOSED
SECURITY
FENCE

擬建行車橋
PROPOSED
VEHICULAR
BRIDGE

平原河
PING YUEN RIVER

橫切面 SECTION 1-1

施工區界限
WORKS BOUNDARY

擬建西行行車道
PROPOSED
WESTBOUND
CARRIAGEWAY

擬建東行行車道
PROPOSED
EASTBOUND
CARRIAGEWAY

擬建行人路
PROPOSED
FOOTPATH

擬建行人路
PROPOSED
FOOTPATH

擬建7.3米
雙線雙程行車道
PROPOSED 7.3m
TWO-LANE TWO-WAY
CARRIAGEWAY

橫切面 SECTION 2-2

圖則名稱 plan title

工務計劃項目第6863TH號蓮麻坑路西段(平原河至坪輦路)擴闊工程 - 切面圖

PWP ITEM NO. 6863TH WIDENING OF WESTERN SECTION OF LIN MA HANG ROAD
BETWEEN PING YUEN RIVER AND PING CHE ROAD - SECTIONS

圖則編號 plan no.

HMW6863TH-SK0008

比例 scale

示意圖
DIAGRAMMATIC

© 版權所有 COPYRIGHT RESERVED



HIGHWAYS
DEPARTMENT
HONG KONG

路
政
署
香
港

圖例
LEGEND:

-  粉嶺北新發展區界線
BOUNDARY OF FANLING NORTH NEW DEVELOPMENT AREA
-  擬議工程項目範圍
PROPOSED WORKS BOUNDARY
-  擬議道路工程 (包括合適的噪音緩減設施及基礎設施)
PROPOSED ROAD WORKS (WITH APPROPRIATE NOISE MITIGATION MEASURES AND INFRASTRUCTURE WORKS)
-  擬議地盤平整 (包括合適的基礎設施)
PROPOSED SITE FORMATION (WITH APPROPRIATE INFRASTRUCTURE WORKS)
-  擬議重置北區臨時農產品批發市場
PROPOSED REPROVISIONING OF NORTH DISTRICT TEMPORARY WHOLESALE MARKET FOR AGRICULTURAL PRODUCTS
-  擬議粉嶺北污水泵房
PROPOSED FANLING NORTH SEWAGE PUMPING STATION
-  擬議重置安樂門街遊樂場
PROPOSED REPROVISIONING OF ON LOK MUN STREET PLAYGROUND
-  擬議擴建及提升石湖墟污水處理廠
PROPOSED EXPANSION AND UPGRADING OF SHEK WU HUI SEWAGE TREATMENT WORKS

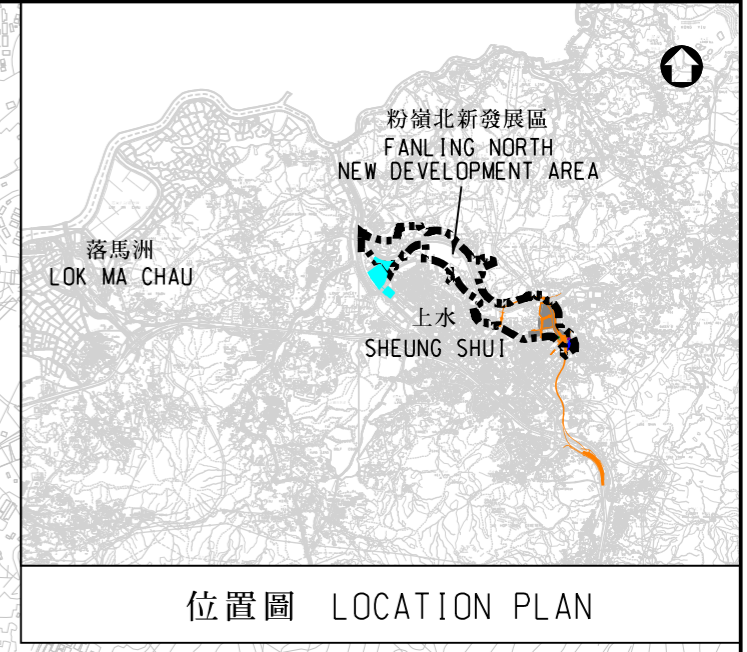
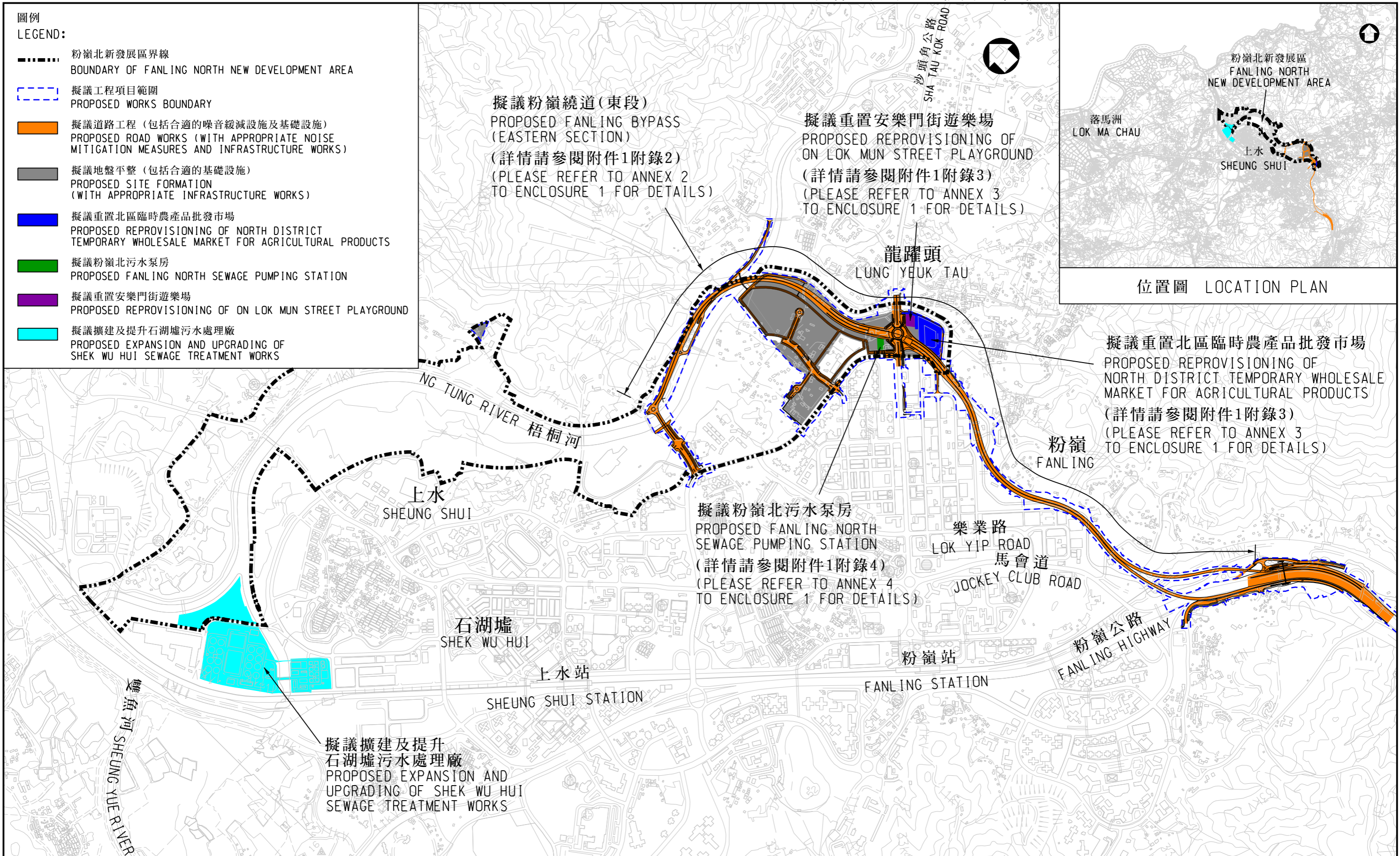

位置圖 LOCATION PLAN

工務計劃項目第747CL號
古洞北新發展區及粉嶺北新發展區前期地盤平整和基礎設施工程-平面圖 (粉嶺北新發展區)
PWP ITEM NO. 747CL
ADVANCE SITE FORMATION AND INFRASTRUCTURE WORKS FOR KWU TUNG NORTH NEW DEVELOPMENT AREA AND FANLING NORTH NEW DEVELOPMENT AREA-
LAYOUT PLAN (FANLING NORTH NEW DEVELOPMENT AREA)

**Construction of Fanling Bypass (Eastern Section) –
under CEDD project number 7747CL**

Appendix B

Planned / Committed Infrastructures in North District

LEGEND:

- BOUNDARY OF KWU TUNG NORTH NEW DEVELOPMENT AREA

- PWP ITEM NO. 828CL - REMAINING PHASE OF SITE FORMATION AND ENGINEERING INFRASTRUCTURE WORKS AT KWU TUNG NORTH NEW DEVELOPMENT AREA AND FANLING NORTH NEW DEVELOPMENT AREA (REMAINING PHASE WORKS)

- PWP ITEM NOS. 747CL & 759CL - ADVANCE WORKS AND FIRST STAGE WORKS FOR DEVELOPMENT AT KWU TUNG NORTH NEW DEVELOPMENT AREA AND FANLING NORTH NEW DEVELOPMENT AREA (FIRST PHASE WORKS)

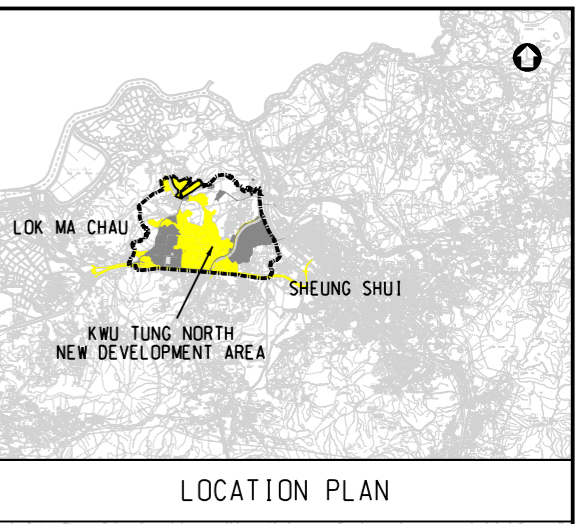
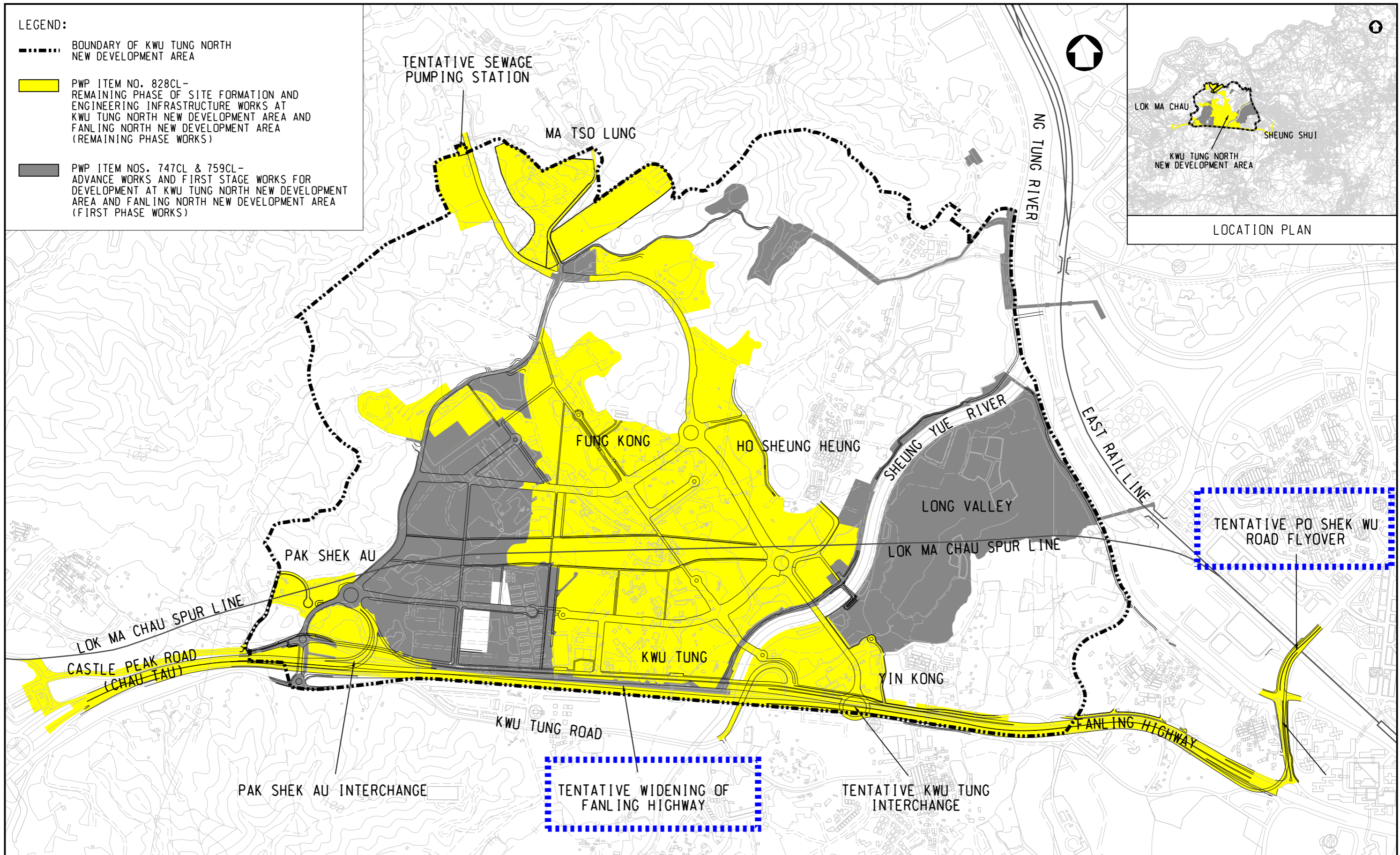

圖則名稱 drawing title PHASING OF THE DEVELOPMENT OF KWU TUNG NORTH AND FANLING NORTH NEW DEVELOPMENT AREAS - LAYOUT PLAN (KWU TUNG NORTH NEW DEVELOPMENT AREA)	繪圖 drawn	簽署 initial	日期 date	項目編號 item no.	辦事處 office 北拓展處 NORTH DEVELOPMENT OFFICE 土木工程拓展署 CIVIL ENGINEERING AND DEVELOPMENT DEPARTMENT
	W K LAU		04.04.19		
	核對 checked	簽署 initial	日期 date	比例 scale	
P Y MAK		04.04.19	1:12 000 (A3)		
核准 approved	簽署 initial	日期 date	圖則編號 drawing no.		
F O HO		04.04.19	CDNKFNZ0117		

LEGEND:

- BOUNDARY OF FANLING NORTH NEW DEVELOPMENT AREA

- PWP ITEM NO. 828CL - REMAINING PHASE OF SITE FORMATION AND ENGINEERING INFRASTRUCTURE WORKS AT KWU TUNG NORTH NEW DEVELOPMENT AREA AND FANLING NORTH NEW DEVELOPMENT AREA (REMAINING PHASE WORKS)

- PWP ITEM NOS. 747CL & 759CL - ADVANCE WORKS AND FIRST STAGE WORKS FOR DEVELOPMENT AT KWU TUNG NORTH NEW DEVELOPMENT AREA AND FANLING NORTH NEW DEVELOPMENT AREA (FIRST PHASE WORKS)

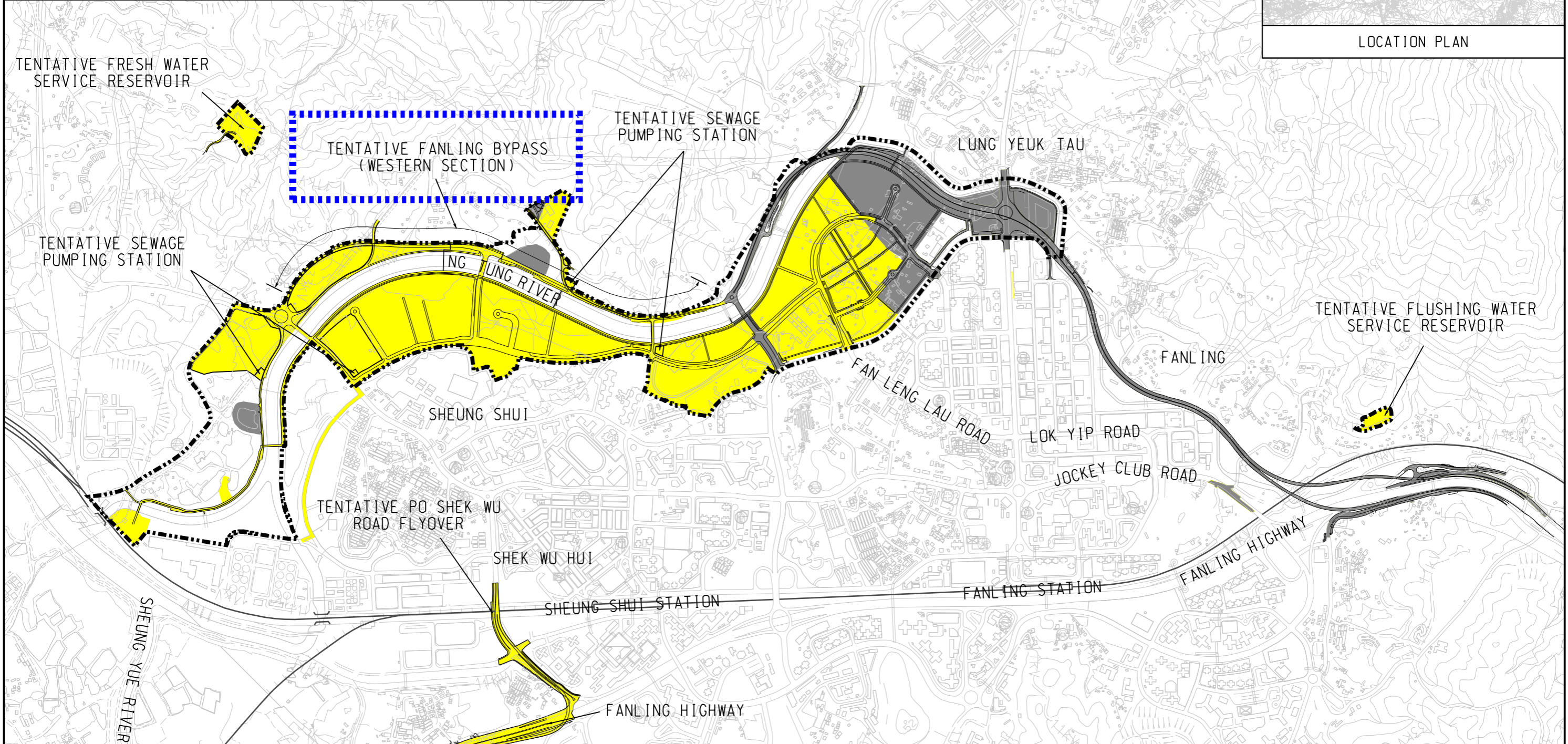
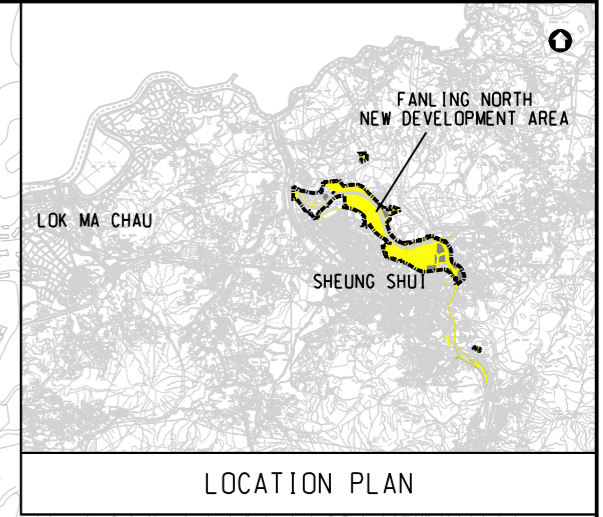

圖則名稱 drawing title PHASING OF THE DEVELOPMENT OF KWU TUNG NORTH AND FANLING NORTH NEW DEVELOPMENT AREAS - LAYOUT PLAN (FANLING NORTH NEW DEVELOPMENT AREA)	繪圖 drawn	簽署 initial	日期 date	項目編號 item no.	辦事處 office 北拓展處 NORTH DEVELOPMENT OFFICE 土木工程拓展署 CIVIL ENGINEERING AND DEVELOPMENT DEPARTMENT
	W K LAU		04.04.19		
	核對 checked	簽署 initial	日期 date	比例 scale	
P Y MAK		04.04.19	1:15 000 (A3)		
核准 approved	簽署 initial	日期 date	圖則編號 drawing no.		
F O HO		04.04.19	CDNKFNZ0118		

Summary of Junction Improvement Schemes

Junction		Description	Proposed by Project	Anticipated Implementation Schedule	Plan No.
J2	Po Shek Wu Road/ Po Wan Road	- Lane arrangement of Po Shek Wu Road southbound to be revised for allowing straight-ahead traffic to use three traffic lanes	Kong Nga Po	2023	H-6b
		- Lane arrangement of Po Wan Road eastbound to be revised for allowing right-turn traffic to use two traffic lanes			
		- Land arrangement of Po Shek Wu Road northbound to be revised for allowing left-turn traffic to use two traffic lanes	Sheung Shui Areas 4 and 30 (junction improvement works to be incorporated in Kong Nga Po project)	2023	H-6b
		- Local widening of Po Wan Road westbound from 1 to 2 lanes			
J3	Po Shek Wu Road/ Choi Yuen Road	- Lane arrangement of Choi Yuen Road westbound to be revised for providing two left-turn lanes	Queen's Hill	Completed	H-6c
		- Local widening of Po Shek Wu Road northbound to allow straight-ahead traffic to use three traffic lanes	Kong Nga Po	2023	H-6d
		- Po Shek Wu Road Interchange Improvement which provides a flyover to allow the right turning traffic from Po Shek Wu Road southbound to Fanling Highway westbound to bypass the existing Po Shek Wu Road Interchange	Kwu Tung North and Fanling North New Development Area (NDA)	2029	H-6e
		- Po Shek Wu Road southbound would be narrowed from 5 lanes to 4 lanes			

Junction	Description	Proposed by Project	Anticipated Implementation Schedule	Plan No.
J5	<ul style="list-style-type: none"> - Lane arrangement of Lung Sum Avenue northbound/southbound to be revised for allowing straight-ahead traffic to use two traffic lanes - Widening Lung Sum Avenue northbound by narrowing the central median of Lung Sum Avenue 	Queen's Hill	2021	H-6f
	<ul style="list-style-type: none"> - Local widening with one additional straight-ahead traffic lane on Jockey Club Road eastbound - Local widening with one additional straight-ahead traffic lane on Lung Sum Avenue northbound 	Kong Nga Po	2023	H-6g
J6	<ul style="list-style-type: none"> - Lane arrangement of Jockey Club Road northbound to be revised for allowing left turn traffic to use two traffic lanes - Method-of-control to be revised for minimising/optimising the intergreen time - Lane arrangement of Ma Sik Road southbound to be revised for allowing three traffic lanes for vehicles to travel straight ahead - Local widening of So Kwun Po Road southbound from 2 to 3 lanes 	Kwu Tung North and Fanling NDA	2023	H-6h

Junction	Description	Proposed by Project	Anticipated Implementation Schedule	Plan No.	
	<ul style="list-style-type: none"> - Local widening with one additional straight-ahead traffic lane on So Kwun Po Road northbound - Local widening of Ma Sik Road northbound from 2 to 3 lanes 	Sheung Shui Areas 4 and 30 (junction improvement works to be incorporated in Kwu Tung North and Fanling NDA project)	2023	H-6h	
J7	So Kwun Po Road Interchange	<ul style="list-style-type: none"> - Local widening of southbound approach arm of So Kwun Po Road for a smoother entrance to the elevated roundabout 	Queen's Hill	2021	H-6i
		<ul style="list-style-type: none"> - New infrastructure to connect the northern and southern side of Fanling Highway 	Subject to further study	n.a	n.a.
J8	Po Shek Wu Road Interchange	<ul style="list-style-type: none"> - Local widening of southbound approach arm of Po Shek Wu Road to 10m to have two traffic lanes when approaching the roundabout 	Queen's Hill	2021	H-6j
		<ul style="list-style-type: none"> - Local widening of the entry arm of Fanling Highway westbound slip road from existing two lanes to three lanes 	Kong Nga Po	2023	H-6k
		<ul style="list-style-type: none"> - Local widening section of southbound of Po Shek Wu Road between Choi Yuen Road and Po Shek Wu Road Interchange 	Sheung Shui Areas 4 and 30	2023/24	H-6l
		<ul style="list-style-type: none"> - Po Shek Wu Road Interchange Improvement which provides a flyover to allow the right turning traffic from Po Shek Wu Road southbound to Fanling Highway westbound to bypass the existing Po Shek Wu Road Interchange 	Kwu Tung North and Fanling NDA	2029	H-6e

Appendix C

Junction Calculation Sheets

PROJECT NO: 287082 DESIGNED BY:

J1 - Lin Ma Hang Road / Man Kam To Road

J1_2023_EXT_AM

DATE : 16/12/2024 FILENAME :

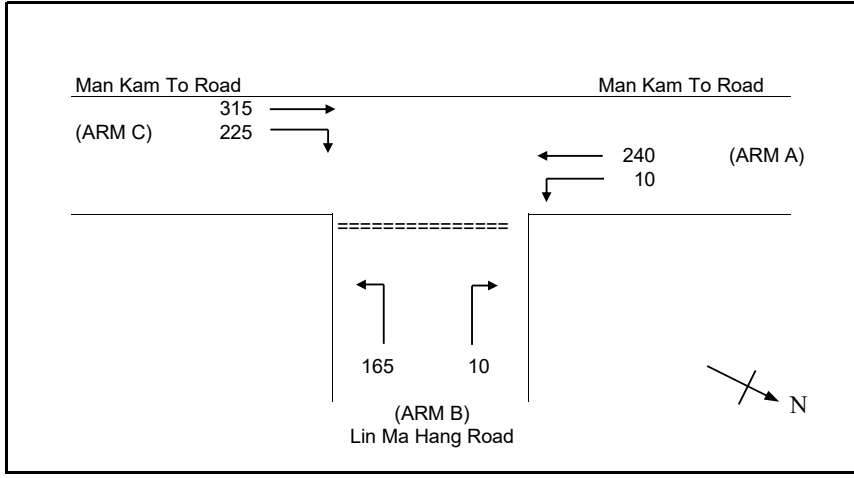

- NOTES : (GEOMETRIC INPUT DATA)
- W = MAJOR ROAD WIDTH (6-20m) (minor road turn left only, 2W)
 - W cr = CENTRAL RESERVE WIDTH (0m, 1.2-9m)
 - W b-a = LANE WIDTH AVAILABLE TO VEHICLE WAITING IN STREAM b-a (0m, 2.2-5m)
 - W b-c = LANE WIDTH AVAILABLE TO VEHICLE WAITING IN STREAM b-c (2.2-5m)
 - W c-b = LANE WIDTH AVAILABLE TO VEHICLE WAITING IN STREAM c-b (0m, 2.2-5m)
 - VI b-a = VISIBILITY TO THE LEFT FOR VEHICLES WAITING IN STREAM b-a (0-250m)
 - Vr b-a = VISIBILITY TO THE RIGHT FOR VEHICLES WAITING IN STREAM b-a (0-250)
 - Vr b-c = VISIBILITY TO THE RIGHT FOR VEHICLES WAITING IN STREAM b-c (0-250)
 - Vr c-b = VISIBILITY TO THE RIGHT FOR VEHICLES WAITING IN STREAM c-b (0-250)
 - D = STREAM-SPECIFIC B-A
 - E = STREAM-SPECIFIC B-C
 - F = STREAM-SPECIFIC C-B
 - Y = (1-0.0345W)

GEOMETRIC DETAILS:

MAJOR ROAD (ARM A)
 W = 12.50 (metres)
 W cr = 0.00 (metres)
 q a-b = 10 (pcu/hr)
 q a-c = 240 (pcu/hr)

MAJOR ROAD (ARM C)
 W c-b = 5.00 (metres)
 Vr c-b = 100 (metres)
 q c-a = 315 (pcu/hr)
 q c-b = 225 (pcu/hr)

MINOR ROAD (ARM B)
 W b-a = 4.50 (metres)
 W b-c = 4.50 (metres)
 VI b-a = 80 (metres)
 Vr b-a = 125 (metres)
 Vr b-c = 125 (metres)
 q b-a = 10 (pcu/hr)
 q b-c = 165 (pcu/hr)

GEOMETRIC FACTORS :

D = 1.04
 E = 1.08
 F = 1.11
 Y = 0.57

THE CAPACITY OF MOVEMENT :

Q b-a = 487
 Q b-c = 753
 Q c-b = 767
 Q b-ac = 730

TOTAL FLOW = 965 (PCU/HR)

COMPARISON OF DESIGN FLOW TO CAPACITY:

DFC b-a = 0.02
 DFC b-c = 0.22
 DFC c-b = 0.29
 DFC b-ac = 0.24

CRITICAL DFC = 0.29

PROJECT NO: 287082 DESIGNED BY:

J1 - Lin Ma Hang Road / Man Kam To Road

J1_2023_EXT_PM

DATE : 16/12/2024 FILENAME :

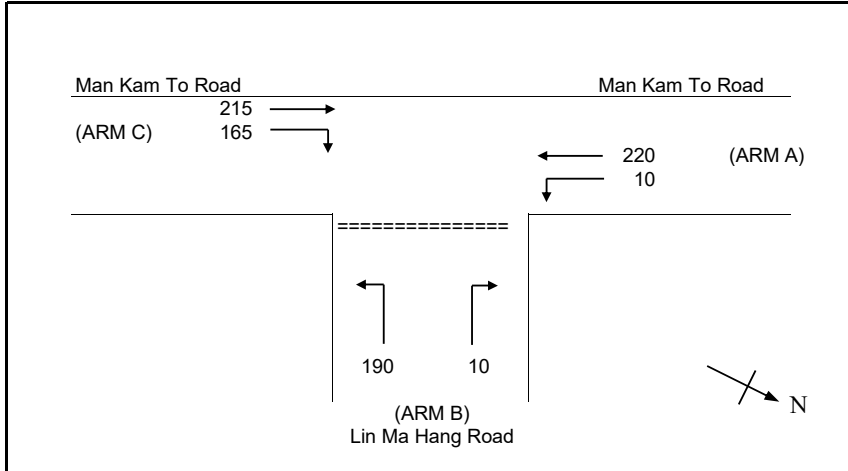

NOTES : (GEOMETRIC INPUT DATA)

- W = MAJOR ROAD WIDTH (6-20m) (minor road turn left only, 2W)
- W cr = CENTRAL RESERVE WIDTH (0m, 1.2-9m)
- W b-a = LANE WIDTH AVAILABLE TO VEHICLE WAITING IN STREAM b-a (0m, 2.2-5m)
- W b-c = LANE WIDTH AVAILABLE TO VEHICLE WAITING IN STREAM b-c (2.2-5m)
- W c-b = LANE WIDTH AVAILABLE TO VEHICLE WAITING IN STREAM c-b (0m, 2.2-5m)
- VI b-a = VISIBILITY TO THE LEFT FOR VEHICLES WAITING IN STREAM b-a (0-250m)
- Vr b-a = VISIBILITY TO THE RIGHT FOR VEHICLES WAITING IN STREAM b-a (0-250)
- Vr b-c = VISIBILITY TO THE RIGHT FOR VEHICLES WAITING IN STREAM b-c (0-250)
- Vr c-b = VISIBILITY TO THE RIGHT FOR VEHICLES WAITING IN STREAM c-b (0-250)
- D = STREAM-SPECIFIC B-A
- E = STREAM-SPECIFIC B-C
- F = STREAM-SPECIFIC C-B
- Y = (1-0.0345W)

GEOMETRIC DETAILS:

MAJOR ROAD (ARM A)
 W = 12.50 (metres)
 W cr = 0.00 (metres)
 q a-b = 10 (pcu/hr)
 q a-c = 220 (pcu/hr)

MAJOR ROAD (ARM C)
 W c-b = 5.00 (metres)
 Vr c-b = 100 (metres)
 q c-a = 215 (pcu/hr)
 q c-b = 165 (pcu/hr)

MINOR ROAD (ARM B)
 W b-a = 4.50 (metres)
 W b-c = 4.50 (metres)
 VI b-a = 80 (metres)
 Vr b-a = 125 (metres)
 Vr b-c = 125 (metres)
 q b-a = 10 (pcu/hr)
 q b-c = 190 (pcu/hr)

GEOMETRIC FACTORS :

D = 1.04
 E = 1.08
 F = 1.11
 Y = 0.57

THE CAPACITY OF MOVEMENT :

Q b-a = 524
 Q b-c = 758
 Q c-b = 772
 Q b-ac = 741

TOTAL FLOW = 810 (PCU/HR)

COMPARISON OF DESIGN FLOW TO CAPACITY:

DFC b-a = 0.02
 DFC b-c = 0.25
 DFC c-b = 0.21
 DFC b-ac = 0.27

CRITICAL DFC = 0.27

PROJECT NO: 287082 DESIGNED BY:

J1 - Lin Ma Hang Road / Man Kam To Road

J1_2031_REF_AM

DATE : 16/12/2024 FILENAME :

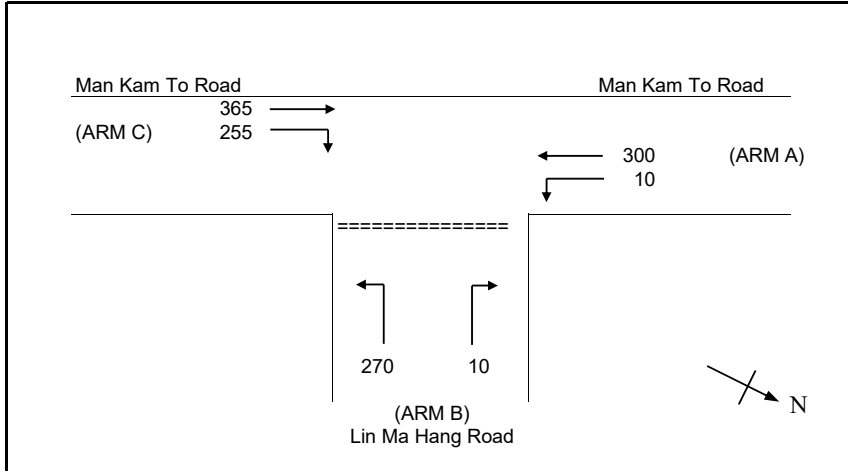

NOTES : (GEOMETRIC INPUT DATA)

- W = MAJOR ROAD WIDTH (6-20m) (minor road turn left only, 2W)
- W cr = CENTRAL RESERVE WIDTH (0m, 1.2-9m)
- W b-a = LANE WIDTH AVAILABLE TO VEHICLE WAITING IN STREAM b-a (0m, 2.2-5m)
- W b-c = LANE WIDTH AVAILABLE TO VEHICLE WAITING IN STREAM b-c (2.2-5m)
- W c-b = LANE WIDTH AVAILABLE TO VEHICLE WAITING IN STREAM c-b (0m, 2.2-5m)
- VI b-a = VISIBILITY TO THE LEFT FOR VEHICLES WAITING IN STREAM b-a (0-250m)
- Vr b-a = VISIBILITY TO THE RIGHT FOR VEHICLES WAITING IN STREAM b-a (0-250)
- Vr b-c = VISIBILITY TO THE RIGHT FOR VEHICLES WAITING IN STREAM b-c (0-250)
- Vr c-b = VISIBILITY TO THE RIGHT FOR VEHICLES WAITING IN STREAM c-b (0-250)
- D = STREAM-SPECIFIC B-A
- E = STREAM-SPECIFIC B-C
- F = STREAM-SPECIFIC C-B
- Y = (1-0.0345W)

GEOMETRIC DETAILS:

MAJOR ROAD (ARM A)
 W = 12.50 (metres)
 W cr = 0.00 (metres)
 q a-b = 10 (pcu/hr)
 q a-c = 300 (pcu/hr)

MAJOR ROAD (ARM C)
 W c-b = 5.00 (metres)
 Vr c-b = 100 (metres)
 q c-a = 365 (pcu/hr)
 q c-b = 255 (pcu/hr)

MINOR ROAD (ARM B)
 W b-a = 4.50 (metres)
 W b-c = 4.50 (metres)
 VI b-a = 80 (metres)
 Vr b-a = 125 (metres)
 Vr b-c = 125 (metres)
 q b-a = 10 (pcu/hr)
 q b-c = 270 (pcu/hr)

GEOMETRIC FACTORS :

D = 1.04
 E = 1.08
 F = 1.11
 Y = 0.57

THE CAPACITY OF MOVEMENT :

Q b-a = 458
 Q b-c = 740
 Q c-b = 753
 Q b-ac = 724

TOTAL FLOW = 1210 (PCU/HR)

COMPARISON OF DESIGN FLOW TO CAPACITY:

DFC b-a = 0.03
 DFC b-c = 0.37
 DFC c-b = 0.34
 DFC b-ac = 0.39

CRITICAL DFC = 0.39

PROJECT NO: 287082 DESIGNED BY:

J1 - Lin Ma Hang Road / Man Kam To Road

J1_2031_REF_PM

DATE : 16/12/2024 FILENAME :

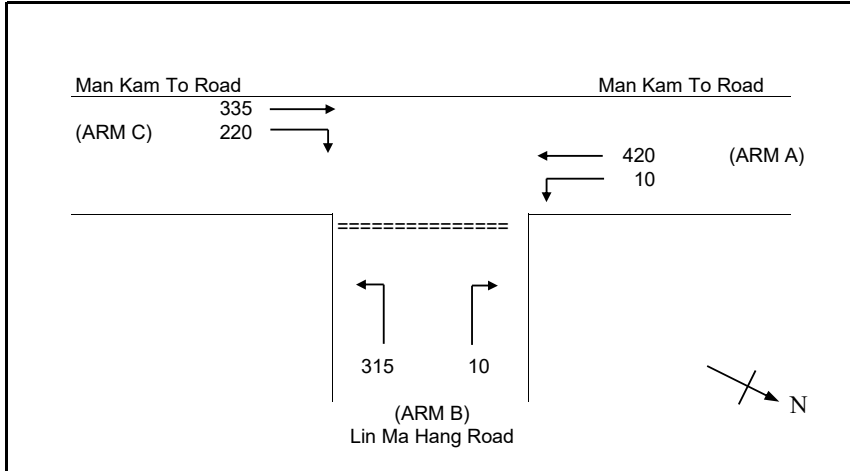

NOTES : (GEOMETRIC INPUT DATA)

- W = MAJOR ROAD WIDTH (6-20m) (minor road turn left only, 2W)
- W cr = CENTRAL RESERVE WIDTH (0m, 1.2-9m)
- W b-a = LANE WIDTH AVAILABLE TO VEHICLE WAITING IN STREAM b-a (0m, 2.2-5m)
- W b-c = LANE WIDTH AVAILABLE TO VEHICLE WAITING IN STREAM b-c (2.2-5m)
- W c-b = LANE WIDTH AVAILABLE TO VEHICLE WAITING IN STREAM c-b (0m, 2.2-5m)
- VI b-a = VISIBILITY TO THE LEFT FOR VEHICLES WAITING IN STREAM b-a (0-250m)
- Vr b-a = VISIBILITY TO THE RIGHT FOR VEHICLES WAITING IN STREAM b-a (0-250)
- Vr b-c = VISIBILITY TO THE RIGHT FOR VEHICLES WAITING IN STREAM b-c (0-250)
- Vr c-b = VISIBILITY TO THE RIGHT FOR VEHICLES WAITING IN STREAM c-b (0-250)
- D = STREAM-SPECIFIC B-A
- E = STREAM-SPECIFIC B-C
- F = STREAM-SPECIFIC C-B
- Y = (1-0.0345W)

GEOMETRIC DETAILS:

MAJOR ROAD (ARM A)
 W = 12.50 (metres)
 W cr = 0.00 (metres)
 q a-b = 10 (pcu/hr)
 q a-c = 420 (pcu/hr)

MAJOR ROAD (ARM C)
 W c-b = 5.00 (metres)
 Vr c-b = 100 (metres)
 q c-a = 335 (pcu/hr)
 q c-b = 220 (pcu/hr)

MINOR ROAD (ARM B)
 W b-a = 4.50 (metres)
 W b-c = 4.50 (metres)
 VI b-a = 80 (metres)
 Vr b-a = 125 (metres)
 Vr b-c = 125 (metres)
 q b-a = 10 (pcu/hr)
 q b-c = 315 (pcu/hr)

GEOMETRIC FACTORS :

D = 1.04
 E = 1.08
 F = 1.11
 Y = 0.57

THE CAPACITY OF MOVEMENT :

Q b-a = 447
 Q b-c = 713
 Q c-b = 726
 Q b-ac = 700

TOTAL FLOW = 1310 (PCU/HR)

COMPARISON OF DESIGN FLOW TO CAPACITY:

DFC b-a = 0.03
 DFC b-c = 0.45
 DFC c-b = 0.31
 DFC b-ac = 0.47

CRITICAL DFC = 0.47

PROJECT NO: 287082 DESIGNED BY:

J1 - Lin Ma Hang Road / Man Kam To Road

J1_2031_DES_AM

DATE : 16/12/2024 FILENAME :

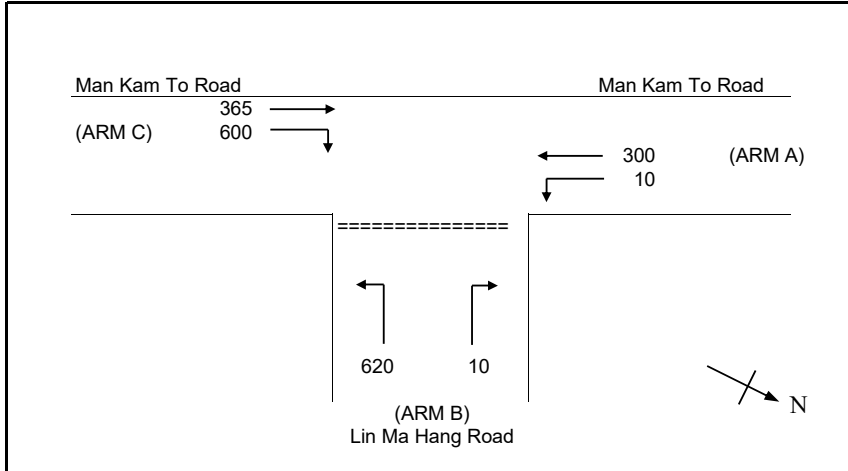

NOTES : (GEOMETRIC INPUT DATA)

- W = MAJOR ROAD WIDTH (6-20m) (minor road turn left only, 2W)
- W cr = CENTRAL RESERVE WIDTH (0m, 1.2-9m)
- W b-a = LANE WIDTH AVAILABLE TO VEHICLE WAITING IN STREAM b-a (0m, 2.2-5m)
- W b-c = LANE WIDTH AVAILABLE TO VEHICLE WAITING IN STREAM b-c (2.2-5m)
- W c-b = LANE WIDTH AVAILABLE TO VEHICLE WAITING IN STREAM c-b (0m, 2.2-5m)
- VI b-a = VISIBILITY TO THE LEFT FOR VEHICLES WAITING IN STREAM b-a (0-250m)
- Vr b-a = VISIBILITY TO THE RIGHT FOR VEHICLES WAITING IN STREAM b-a (0-250)
- Vr b-c = VISIBILITY TO THE RIGHT FOR VEHICLES WAITING IN STREAM b-c (0-250)
- Vr c-b = VISIBILITY TO THE RIGHT FOR VEHICLES WAITING IN STREAM c-b (0-250)
- D = STREAM-SPECIFIC B-A
- E = STREAM-SPECIFIC B-C
- F = STREAM-SPECIFIC C-B
- Y = (1-0.0345W)

GEOMETRIC DETAILS:

MAJOR ROAD (ARM A)
 W = 12.50 (metres)
 W cr = 0.00 (metres)
 q a-b = 10 (pcu/hr)
 q a-c = 300 (pcu/hr)

MAJOR ROAD (ARM C)
 W c-b = 5.00 (metres)
 Vr c-b = 100 (metres)
 q c-a = 365 (pcu/hr)
 q c-b = 600 (pcu/hr)

MINOR ROAD (ARM B)
 W b-a = 4.50 (metres)
 W b-c = 4.50 (metres)
 VI b-a = 80 (metres)
 Vr b-a = 125 (metres)
 Vr b-c = 125 (metres)
 q b-a = 10 (pcu/hr)
 q b-c = 620 (pcu/hr)

GEOMETRIC FACTORS :

D = 1.04
 E = 1.08
 F = 1.11
 Y = 0.57

THE CAPACITY OF MOVEMENT :

Q b-a = 352
 Q b-c = 740
 Q c-b = 753
 Q b-ac = 727

TOTAL FLOW = 1905 (PCU/HR)

COMPARISON OF DESIGN FLOW TO CAPACITY:

DFC b-a = 0.03
 DFC b-c = 0.84
 DFC c-b = 0.80
 DFC b-ac = 0.87

CRITICAL DFC = 0.87

PROJECT NO: 287082 DESIGNED BY:

J1 - Lin Ma Hang Road / Man Kam To Road

J1_2031_DES_PM

DATE : 16/12/2024 FILENAME :

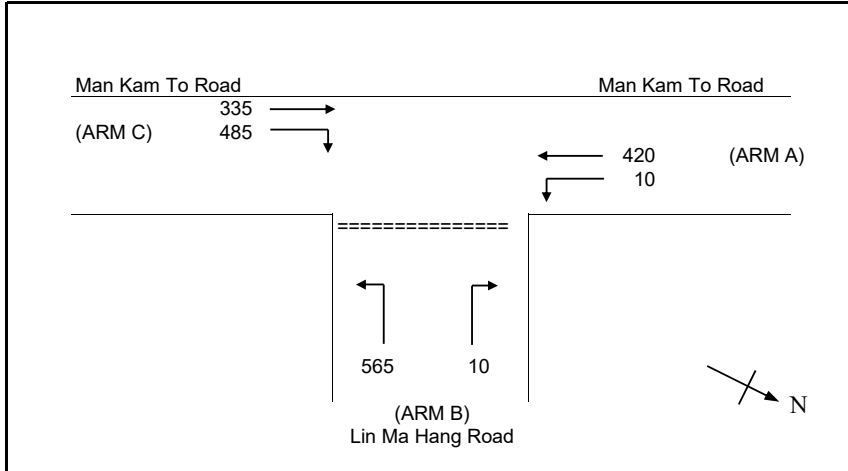

NOTES : (GEOMETRIC INPUT DATA)

- W = MAJOR ROAD WIDTH (6-20m) (minor road turn left only, 2W)
- W cr = CENTRAL RESERVE WIDTH (0m, 1.2-9m)
- W b-a = LANE WIDTH AVAILABLE TO VEHICLE WAITING IN STREAM b-a (0m, 2.2-5m)
- W b-c = LANE WIDTH AVAILABLE TO VEHICLE WAITING IN STREAM b-c (2.2-5m)
- W c-b = LANE WIDTH AVAILABLE TO VEHICLE WAITING IN STREAM c-b (0m, 2.2-5m)
- VI b-a = VISIBILITY TO THE LEFT FOR VEHICLES WAITING IN STREAM b-a (0-250m)
- Vr b-a = VISIBILITY TO THE RIGHT FOR VEHICLES WAITING IN STREAM b-a (0-250)
- Vr b-c = VISIBILITY TO THE RIGHT FOR VEHICLES WAITING IN STREAM b-c (0-250)
- Vr c-b = VISIBILITY TO THE RIGHT FOR VEHICLES WAITING IN STREAM c-b (0-250)
- D = STREAM-SPECIFIC B-A
- E = STREAM-SPECIFIC B-C
- F = STREAM-SPECIFIC C-B
- Y = (1-0.0345W)

GEOMETRIC DETAILS:

MAJOR ROAD (ARM A)
 W = 12.50 (metres)
 W cr = 0.00 (metres)
 q a-b = 10 (pcu/hr)
 q a-c = 420 (pcu/hr)

MAJOR ROAD (ARM C)
 W c-b = 5.00 (metres)
 Vr c-b = 100 (metres)
 q c-a = 335 (pcu/hr)
 q c-b = 485 (pcu/hr)

MINOR ROAD (ARM B)
 W b-a = 4.50 (metres)
 W b-c = 4.50 (metres)
 VI b-a = 80 (metres)
 Vr b-a = 125 (metres)
 Vr b-c = 125 (metres)
 q b-a = 10 (pcu/hr)
 q b-c = 565 (pcu/hr)

GEOMETRIC FACTORS :

D = 1.04
 E = 1.08
 F = 1.11
 Y = 0.57

THE CAPACITY OF MOVEMENT :

Q b-a = 366
 Q b-c = 713
 Q c-b = 726
 Q b-ac = 701

TOTAL FLOW = 1825 (PCU/HR)

COMPARISON OF DESIGN FLOW TO CAPACITY:

DFC b-a = 0.03
 DFC b-c = 0.80
 DFC c-b = 0.67
 DFC b-ac = 0.82

CRITICAL DFC = 0.82

PROJECT NO: 287082 DESIGNED BY:

J2 - Lin Ma Hang Road / Ping Che Road

J2_2023_EXT_AM

DATE : 16/12/2024 FILENAME :

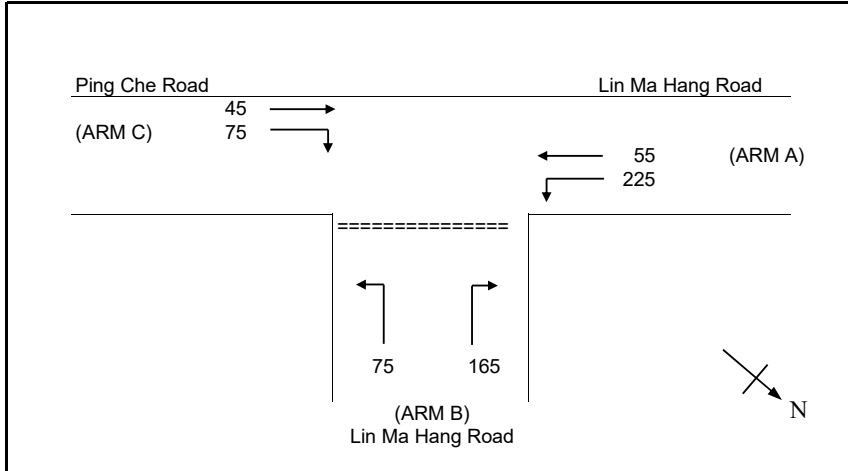

NOTES : (GEOMETRIC INPUT DATA)

- W = MAJOR ROAD WIDTH (6-20m) (minor road turn left only, 2W)
- W cr = CENTRAL RESERVE WIDTH (0m, 1.2-9m)
- W b-a = LANE WIDTH AVAILABLE TO VEHICLE WAITING IN STREAM b-a (0m, 2.2-5m)
- W b-c = LANE WIDTH AVAILABLE TO VEHICLE WAITING IN STREAM b-c (2.2-5m)
- W c-b = LANE WIDTH AVAILABLE TO VEHICLE WAITING IN STREAM c-b (0m, 2.2-5m)
- VI b-a = VISIBILITY TO THE LEFT FOR VEHICLES WAITING IN STREAM b-a (0-250m)
- Vr b-a = VISIBILITY TO THE RIGHT FOR VEHICLES WAITING IN STREAM b-a (0-250)
- Vr b-c = VISIBILITY TO THE RIGHT FOR VEHICLES WAITING IN STREAM b-c (0-250)
- Vr c-b = VISIBILITY TO THE RIGHT FOR VEHICLES WAITING IN STREAM c-b (0-250)
- D = STREAM-SPECIFIC B-A
- E = STREAM-SPECIFIC B-C
- F = STREAM-SPECIFIC C-B
- Y = (1-0.0345W)

GEOMETRIC DETAILS:

MAJOR ROAD (ARM A)
 W = 7.00 (metres)
 W cr = 0.00 (metres)
 q a-b = 225 (pcu/hr)
 q a-c = 55 (pcu/hr)

MAJOR ROAD (ARM C)
 W c-b = 3.30 (metres)
 Vr c-b = 100 (metres)
 q c-a = 45 (pcu/hr)
 q c-b = 75 (pcu/hr)

MINOR ROAD (ARM B)
 W b-a = 3.50 (metres)
 W b-c = 4.50 (metres)
 VI b-a = 200 (metres)
 Vr b-a = 100 (metres)
 Vr b-c = 100 (metres)
 q b-a = 165 (pcu/hr)
 q b-c = 75 (pcu/hr)

GEOMETRIC FACTORS :

D = 1
 E = 1.06
 F = 0.95
 Y = 0.76

THE CAPACITY OF MOVEMENT :

Q b-a = 548
 Q b-c = 748
 Q c-b = 634
 Q b-ac = 598

TOTAL FLOW = 640 (PCU/HR)

COMPARISON OF DESIGN FLOW TO CAPACITY:

DFC b-a = 0.30
 DFC b-c = 0.10
 DFC c-b = 0.12
 DFC b-ac = 0.40

CRITICAL DFC = 0.40

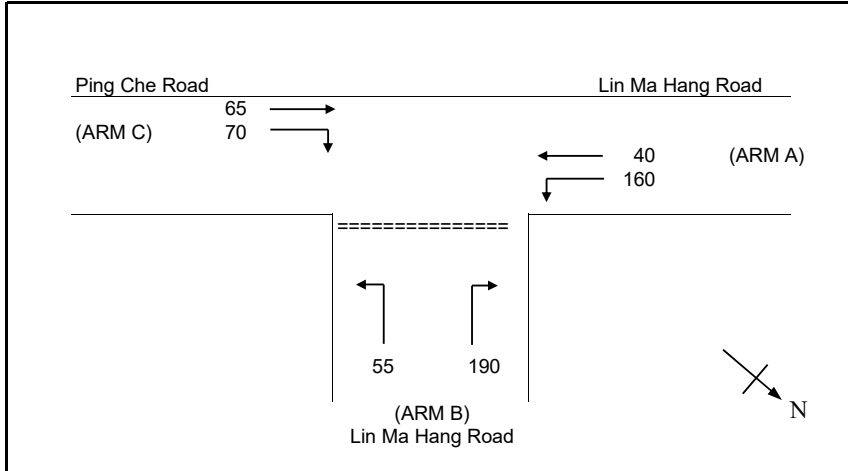

NOTES : (GEOMETRIC INPUT DATA)

- W = MAJOR ROAD WIDTH (6-20m) (minor road turn left only, 2W)
- W cr = CENTRAL RESERVE WIDTH (0m, 1.2-9m)
- W b-a = LANE WIDTH AVAILABLE TO VEHICLE WAITING IN STREAM b-a (0m, 2.2-5m)
- W b-c = LANE WIDTH AVAILABLE TO VEHICLE WAITING IN STREAM b-c (2.2-5m)
- W c-b = LANE WIDTH AVAILABLE TO VEHICLE WAITING IN STREAM c-b (0m, 2.2-5m)
- VI b-a = VISIBILITY TO THE LEFT FOR VEHICLES WAITING IN STREAM b-a (0-250m)
- Vr b-a = VISIBILITY TO THE RIGHT FOR VEHICLES WAITING IN STREAM b-a (0-250)
- Vr b-c = VISIBILITY TO THE RIGHT FOR VEHICLES WAITING IN STREAM b-c (0-250)
- Vr c-b = VISIBILITY TO THE RIGHT FOR VEHICLES WAITING IN STREAM c-b (0-250)
- D = STREAM-SPECIFIC B-A
- E = STREAM-SPECIFIC B-C
- F = STREAM-SPECIFIC C-B
- Y = (1-0.0345W)

GEOMETRIC DETAILS:

MAJOR ROAD (ARM A)

- W = 7.00 (metres)
- W cr = 0.00 (metres)
- q a-b = 160 (pcu/hr)
- q a-c = 40 (pcu/hr)

MAJOR ROAD (ARM C)

- W c-b = 3.30 (metres)
- Vr c-b = 100 (metres)
- q c-a = 65 (pcu/hr)
- q c-b = 70 (pcu/hr)

MINOR ROAD (ARM B)

- W b-a = 3.50 (metres)
- W b-c = 4.50 (metres)
- VI b-a = 200 (metres)
- Vr b-a = 100 (metres)
- Vr b-c = 100 (metres)
- q b-a = 190 (pcu/hr)
- q b-c = 55 (pcu/hr)

GEOMETRIC FACTORS :

- D = 1
- E = 1.06
- F = 0.95
- Y = 0.76

THE CAPACITY OF MOVEMENT :

- Q b-a = 558
- Q b-c = 760
- Q c-b = 655
- Q b-ac = 593

TOTAL FLOW = 580 (PCU/HR)

COMPARISON OF DESIGN FLOW TO CAPACITY:

- DFC b-a = 0.34
- DFC b-c = 0.07
- DFC c-b = 0.11
- DFC b-ac = 0.41

CRITICAL DFC = 0.41

PROJECT NO: 287082 DESIGNED BY:

J2 - Lin Ma Hang Road / Ping Che Road

J2_2031_REF_AM

DATE : 16/12/2024 FILENAME :

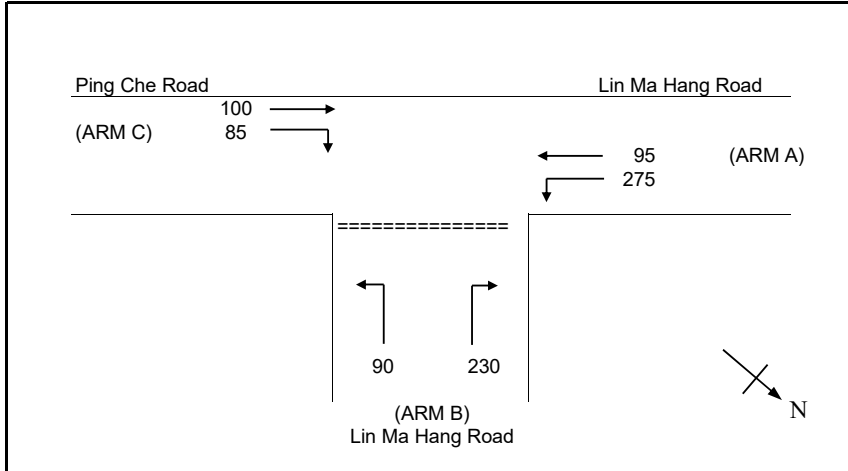

NOTES : (GEOMETRIC INPUT DATA)

- W = MAJOR ROAD WIDTH (6-20m) (minor road turn left only, 2W)
- W cr = CENTRAL RESERVE WIDTH (0m, 1.2-9m)
- W b-a = LANE WIDTH AVAILABLE TO VEHICLE WAITING IN STREAM b-a (0m, 2.2-5m)
- W b-c = LANE WIDTH AVAILABLE TO VEHICLE WAITING IN STREAM b-c (2.2-5m)
- W c-b = LANE WIDTH AVAILABLE TO VEHICLE WAITING IN STREAM c-b (0m, 2.2-5m)
- VI b-a = VISIBILITY TO THE LEFT FOR VEHICLES WAITING IN STREAM b-a (0-250m)
- Vr b-a = VISIBILITY TO THE RIGHT FOR VEHICLES WAITING IN STREAM b-a (0-250)
- Vr b-c = VISIBILITY TO THE RIGHT FOR VEHICLES WAITING IN STREAM b-c (0-250)
- Vr c-b = VISIBILITY TO THE RIGHT FOR VEHICLES WAITING IN STREAM c-b (0-250)
- D = STREAM-SPECIFIC B-A
- E = STREAM-SPECIFIC B-C
- F = STREAM-SPECIFIC C-B
- Y = (1-0.0345W)

GEOMETRIC DETAILS:

MAJOR ROAD (ARM A)
 W = 7.00 (metres)
 W cr = 0.00 (metres)
 q a-b = 275 (pcu/hr)
 q a-c = 95 (pcu/hr)

MAJOR ROAD (ARM C)
 W c-b = 3.30 (metres)
 Vr c-b = 100 (metres)
 q c-a = 100 (pcu/hr)
 q c-b = 85 (pcu/hr)

MINOR ROAD (ARM B)
 W b-a = 3.50 (metres)
 W b-c = 4.50 (metres)
 VI b-a = 200 (metres)
 Vr b-a = 100 (metres)
 Vr b-c = 100 (metres)
 q b-a = 230 (pcu/hr)
 q b-c = 90 (pcu/hr)

GEOMETRIC FACTORS :

D = 1
 E = 1.06
 F = 0.95
 Y = 0.76

THE CAPACITY OF MOVEMENT :

Q b-a = 518
 Q b-c = 730
 Q c-b = 611
 Q b-ac = 564

TOTAL FLOW = 875 (PCU/HR)

COMPARISON OF DESIGN FLOW TO CAPACITY:

DFC b-a = 0.45
 DFC b-c = 0.13
 DFC c-b = 0.14
 DFC b-ac = 0.57

CRITICAL DFC = 0.57

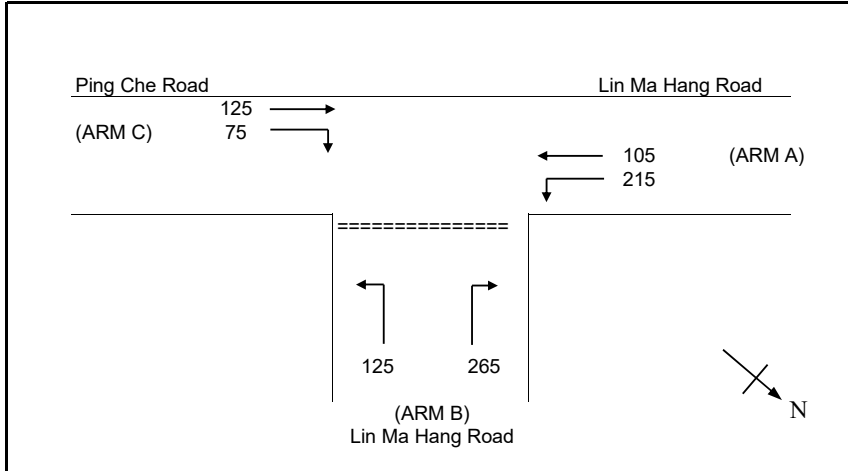

NOTES : (GEOMETRIC INPUT DATA)

- W = MAJOR ROAD WIDTH (6-20m) (minor road turn left only, 2W)
- W cr = CENTRAL RESERVE WIDTH (0m, 1.2-9m)
- W b-a = LANE WIDTH AVAILABLE TO VEHICLE WAITING IN STREAM b-a (0m, 2.2-5m)
- W b-c = LANE WIDTH AVAILABLE TO VEHICLE WAITING IN STREAM b-c (2.2-5m)
- W c-b = LANE WIDTH AVAILABLE TO VEHICLE WAITING IN STREAM c-b (0m, 2.2-5m)
- VI b-a = VISIBILITY TO THE LEFT FOR VEHICLES WAITING IN STREAM b-a (0-250m)
- Vr b-a = VISIBILITY TO THE RIGHT FOR VEHICLES WAITING IN STREAM b-a (0-250)
- Vr b-c = VISIBILITY TO THE RIGHT FOR VEHICLES WAITING IN STREAM b-c (0-250)
- Vr c-b = VISIBILITY TO THE RIGHT FOR VEHICLES WAITING IN STREAM c-b (0-250)
- D = STREAM-SPECIFIC B-A
- E = STREAM-SPECIFIC B-C
- F = STREAM-SPECIFIC C-B
- Y = (1-0.0345W)

GEOMETRIC DETAILS:

MAJOR ROAD (ARM A)
 W = 7.00 (metres)
 W cr = 0.00 (metres)
 q a-b = 215 (pcu/hr)
 q a-c = 105 (pcu/hr)

MAJOR ROAD (ARM C)
 W c-b = 3.30 (metres)
 Vr c-b = 100 (metres)
 q c-a = 125 (pcu/hr)
 q c-b = 75 (pcu/hr)

MINOR ROAD (ARM B)
 W b-a = 3.50 (metres)
 W b-c = 4.50 (metres)
 VI b-a = 200 (metres)
 Vr b-a = 100 (metres)
 Vr b-c = 100 (metres)
 q b-a = 265 (pcu/hr)
 q b-c = 125 (pcu/hr)

GEOMETRIC FACTORS :

D = 1
 E = 1.06
 F = 0.95
 Y = 0.76

THE CAPACITY OF MOVEMENT :

Q b-a = 522
 Q b-c = 734
 Q c-b = 624
 Q b-ac = 575

TOTAL FLOW = 910 (PCU/HR)

COMPARISON OF DESIGN FLOW TO CAPACITY:

DFC b-a = 0.51
 DFC b-c = 0.18
 DFC c-b = 0.13
 DFC b-ac = 0.68

CRITICAL DFC = 0.68

PROJECT NO: 287082 DESIGNED BY:

J2 - Lin Ma Hang Road / Ping Che Road

J2_2031_DES_AM

DATE : 16/12/2024 FILENAME :

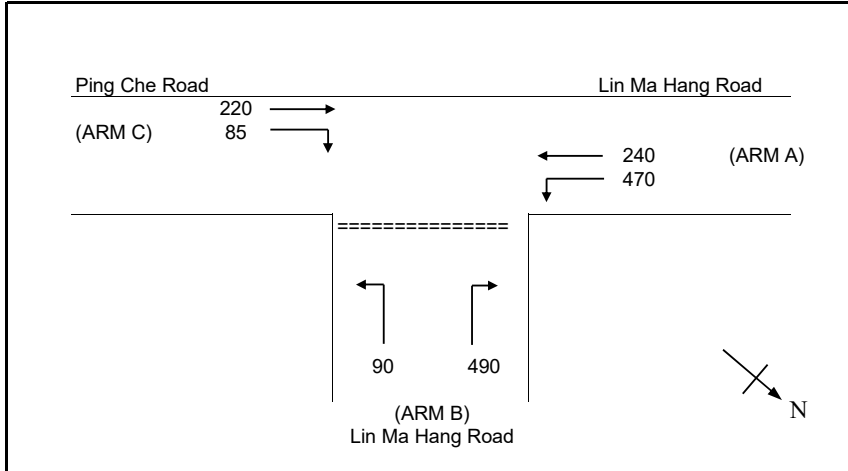

NOTES : (GEOMETRIC INPUT DATA)

- W = MAJOR ROAD WIDTH (6-20m) (minor road turn left only, 2W)
- W cr = CENTRAL RESERVE WIDTH (0m, 1.2-9m)
- W b-a = LANE WIDTH AVAILABLE TO VEHICLE WAITING IN STREAM b-a (0m, 2.2-5m)
- W b-c = LANE WIDTH AVAILABLE TO VEHICLE WAITING IN STREAM b-c (2.2-5m)
- W c-b = LANE WIDTH AVAILABLE TO VEHICLE WAITING IN STREAM c-b (0m, 2.2-5m)
- VI b-a = VISIBILITY TO THE LEFT FOR VEHICLES WAITING IN STREAM b-a (0-250m)
- Vr b-a = VISIBILITY TO THE RIGHT FOR VEHICLES WAITING IN STREAM b-a (0-250)
- Vr b-c = VISIBILITY TO THE RIGHT FOR VEHICLES WAITING IN STREAM b-c (0-250)
- Vr c-b = VISIBILITY TO THE RIGHT FOR VEHICLES WAITING IN STREAM c-b (0-250)
- D = STREAM-SPECIFIC B-A
- E = STREAM-SPECIFIC B-C
- F = STREAM-SPECIFIC C-B
- Y = (1-0.0345W)

GEOMETRIC DETAILS:

MAJOR ROAD (ARM A)

W = 7.00 (metres)
 W cr = 0.00 (metres)
 q a-b = 470 (pcu/hr)
 q a-c = 240 (pcu/hr)

MAJOR ROAD (ARM C)

W c-b = 3.30 (metres)
 Vr c-b = 100 (metres)
 q c-a = 220 (pcu/hr)
 q c-b = 85 (pcu/hr)

MINOR ROAD (ARM B)

W b-a = 3.50 (metres)
 W b-c = 4.50 (metres)
 VI b-a = 200 (metres)
 Vr b-a = 100 (metres)
 Vr b-c = 100 (metres)
 q b-a = 490 (pcu/hr)
 q b-c = 90 (pcu/hr)

GEOMETRIC FACTORS :

D = 1
 E = 1.06
 F = 0.95
 Y = 0.76

THE CAPACITY OF MOVEMENT :

Q b-a = 436
 Q b-c = 665
 Q c-b = 521
 Q b-ac = 461

TOTAL FLOW = 1595 (PCU/HR)

COMPARISON OF DESIGN FLOW TO CAPACITY:

DFC b-a = 1.13
 DFC b-c = 0.14
 DFC c-b = 0.17
 DFC b-ac = 1.26

CRITICAL DFC = 1.26

PROJECT NO: 287082 DESIGNED BY:

J2 - Lin Ma Hang Road / Ping Che Road

J2_2031_DES_PM

DATE : 16/12/2024 FILENAME :

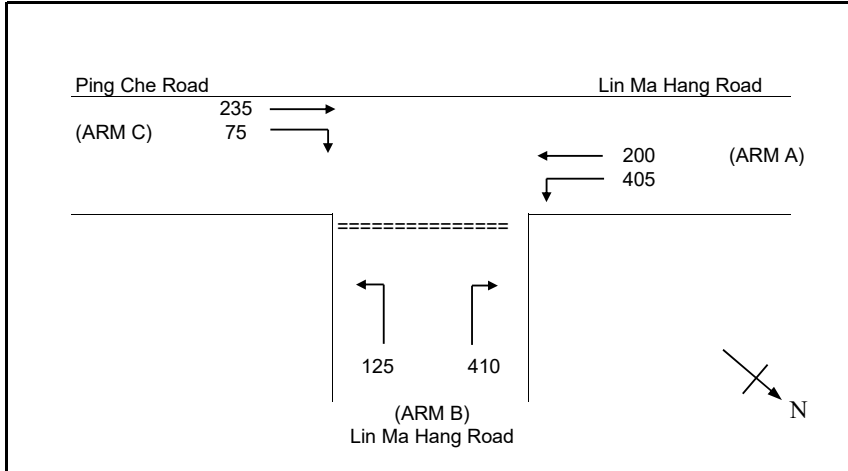

NOTES : (GEOMETRIC INPUT DATA)

- W = MAJOR ROAD WIDTH (6-20m) (minor road turn left only, 2W)
- W cr = CENTRAL RESERVE WIDTH (0m, 1.2-9m)
- W b-a = LANE WIDTH AVAILABLE TO VEHICLE WAITING IN STREAM b-a (0m, 2.2-5m)
- W b-c = LANE WIDTH AVAILABLE TO VEHICLE WAITING IN STREAM b-c (2.2-5m)
- W c-b = LANE WIDTH AVAILABLE TO VEHICLE WAITING IN STREAM c-b (0m, 2.2-5m)
- VI b-a = VISIBILITY TO THE LEFT FOR VEHICLES WAITING IN STREAM b-a (0-250m)
- Vr b-a = VISIBILITY TO THE RIGHT FOR VEHICLES WAITING IN STREAM b-a (0-250)
- Vr b-c = VISIBILITY TO THE RIGHT FOR VEHICLES WAITING IN STREAM b-c (0-250)
- Vr c-b = VISIBILITY TO THE RIGHT FOR VEHICLES WAITING IN STREAM c-b (0-250)
- D = STREAM-SPECIFIC B-A
- E = STREAM-SPECIFIC B-C
- F = STREAM-SPECIFIC C-B
- Y = (1-0.0345W)

GEOMETRIC DETAILS:

MAJOR ROAD (ARM A)
 W = 7.00 (metres)
 W cr = 0.00 (metres)
 q a-b = 405 (pcu/hr)
 q a-c = 200 (pcu/hr)

MAJOR ROAD (ARM C)
 W c-b = 3.30 (metres)
 Vr c-b = 100 (metres)
 q c-a = 235 (pcu/hr)
 q c-b = 75 (pcu/hr)

MINOR ROAD (ARM B)
 W b-a = 3.50 (metres)
 W b-c = 4.50 (metres)
 VI b-a = 200 (metres)
 Vr b-a = 100 (metres)
 Vr b-c = 100 (metres)
 q b-a = 410 (pcu/hr)
 q b-c = 125 (pcu/hr)

GEOMETRIC FACTORS :

D = 1
 E = 1.06
 F = 0.95
 Y = 0.76

THE CAPACITY OF MOVEMENT :

Q b-a = 456
 Q b-c = 685
 Q c-b = 549
 Q b-ac = 495

TOTAL FLOW = 1450 (PCU/HR)

COMPARISON OF DESIGN FLOW TO CAPACITY:

DFC b-a = 0.90
 DFC b-c = 0.19
 DFC c-b = 0.14
 DFC b-ac = 1.09

CRITICAL DFC = 1.09

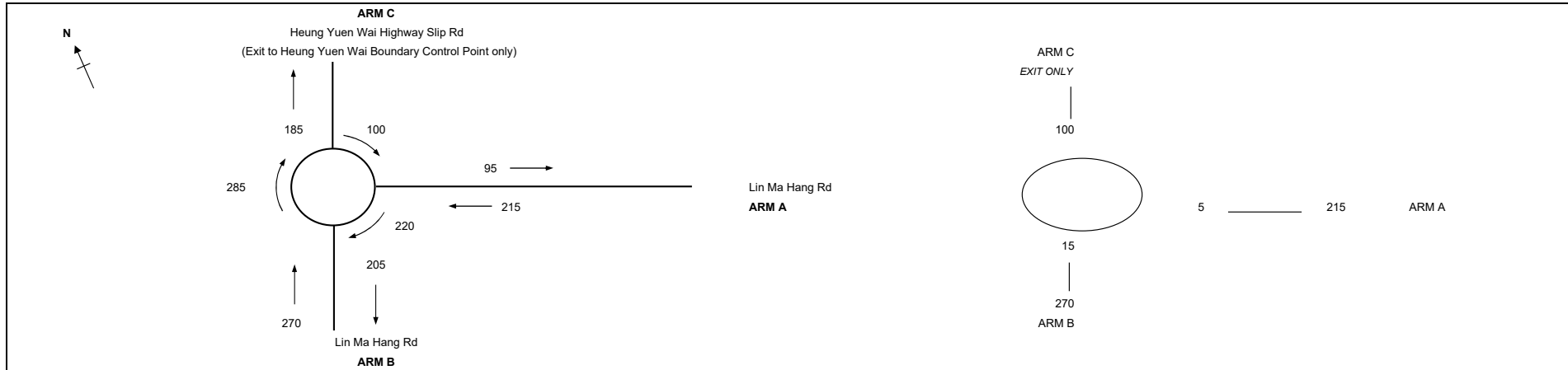

ARM	A	B
INPUT PARAMETERS:		
V = Approach half width (m)	3.65	3.65
E = Entry width (m)	4.00	4.00
L = Effective length of flare (m)	10	10
R = Entry radius (m)	100	45
D = Inscribed circle diameter (m)	25	25
A = Entry angle (degree)	10	15
Q = Entry flow (pcu/h)	215	270
Qc = Circulating flow across entry (pcu/h)	5	15
OUTPUT PARAMETERS:		
S = Sharpness of flare = 1.6(E-V)/L	0.06	0.06
K = 1-0.00347(A-30)-0.978(1/R-0.05)	1.11	1.08
X2 = $V + ((E-V)/(1+2S))$	3.96	3.96
M = $EXP((D-60)/10)$	0.03	0.03
F = 303*X2	1201	1201
Td = 1+(0.5/(1+M))	1.49	1.49
Fc = 0.21*Td(1+0.2*X2)	0.56	0.56
Qe = K(F-Fc*Qc)	1329	1287
DFC = Design flow/Capacity = Q/Qe	0.16	0.21
Total In Sum =		485 PCU
DFC of Critical Approach =		0.21

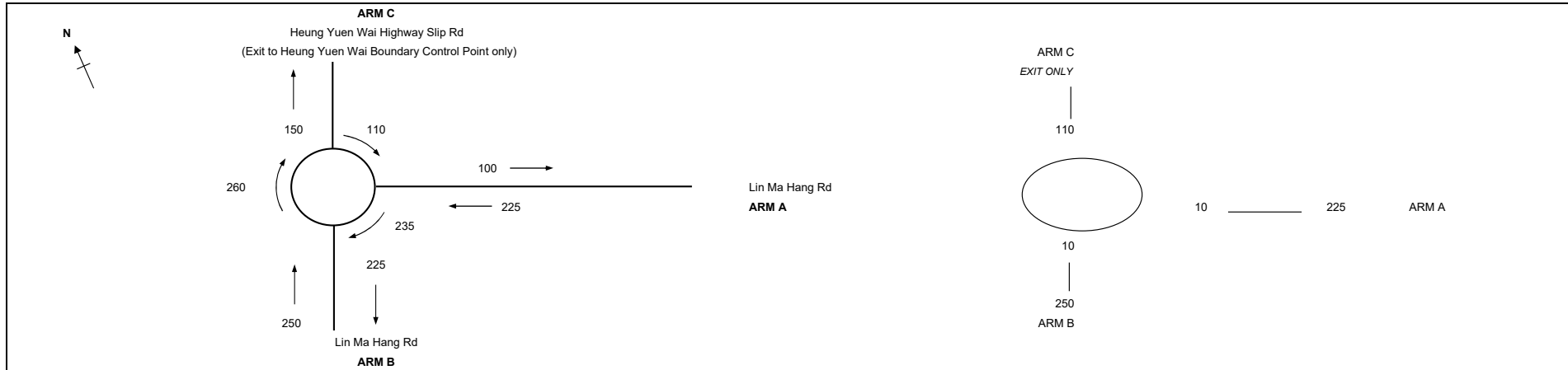

ARM	A	B
INPUT PARAMETERS:		
V = Approach half width (m)	3.65	3.65
E = Entry width (m)	4.00	4.00
L = Effective length of flare (m)	10	10
R = Entry radius (m)	100	45
D = Inscribed circle diameter (m)	25	25
A = Entry angle (degree)	10	15
Q = Entry flow (pcu/h)	225	250
Qc = Circulating flow across entry (pcu/h)	10	10
OUTPUT PARAMETERS:		
S = Sharpness of flare = $1.6(E-V)/L$	0.06	0.06
K = $1-0.00347(A-30)-0.978(1/R-0.05)$	1.11	1.08
X2 = $V + ((E-V)/(1+2S))$	3.96	3.96
M = $EXP((D-60)/10)$	0.03	0.03
F = $303 \times X2$	1201	1201
Td = $1+(0.5/(1+M))$	1.49	1.49
Fc = $0.21 \times Td(1+0.2 \times X2)$	0.56	0.56
Qe = $K(F-Fc \times Qc)$	1325	1290
DFC = Design flow/Capacity = Q/Qe	0.17	0.19
Total In Sum =		475 PCU
DFC of Critical Approach =		0.19

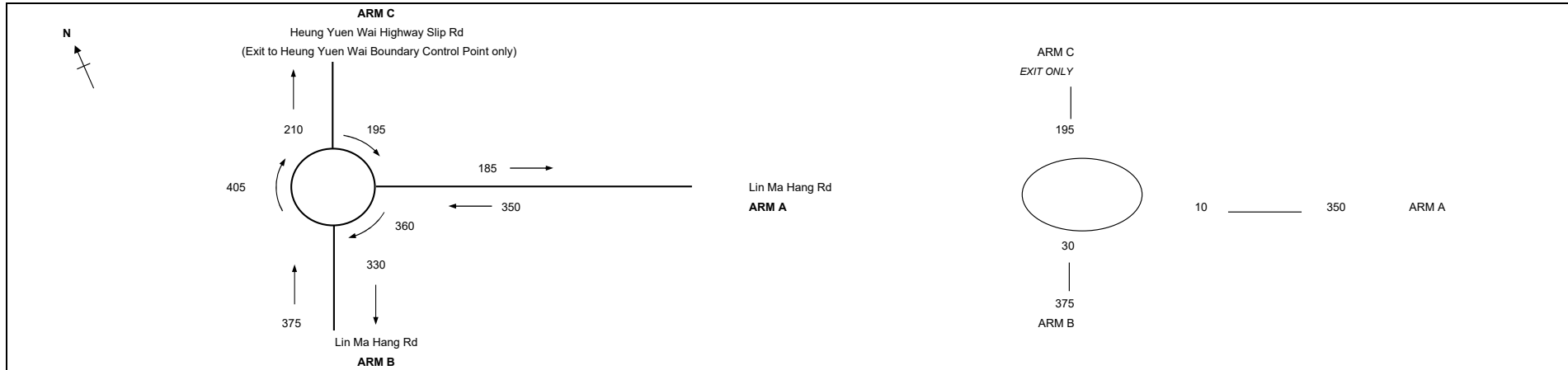

ARM	A	B
INPUT PARAMETERS:		
V = Approach half width (m)	3.65	3.65
E = Entry width (m)	4.00	4.00
L = Effective length of flare (m)	10	10
R = Entry radius (m)	100	45
D = Inscribed circle diameter (m)	25	25
A = Entry angle (degree)	10	15
Q = Entry flow (pcu/h)	350	375
Qc = Circulating flow across entry (pcu/h)	10	30
OUTPUT PARAMETERS:		
S = Sharpness of flare = 1.6(E-V)/L	0.06	0.06
K = 1-0.00347(A-30)-0.978(1/R-0.05)	1.11	1.08
X2 = $V + ((E-V)/(1+2S))$	3.96	3.96
M = $EXP((D-60)/10)$	0.03	0.03
F = 303*X2	1201	1201
Td = 1+(0.5/(1+M))	1.49	1.49
Fc = 0.21*Td(1+0.2*X2)	0.56	0.56
Qe = K(F-Fc*Qc)	1325	1278
DFC = Design flow/Capacity = Q/Qe	0.27	0.30
Total In Sum =		725 PCU
DFC of Critical Approach =		0.30

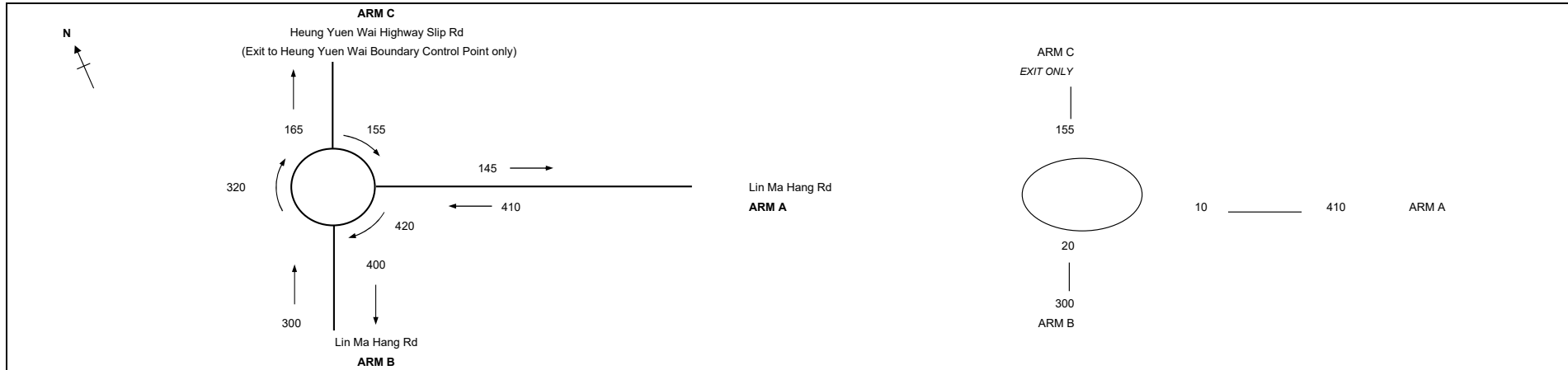

ARM	A	B
INPUT PARAMETERS:		
V = Approach half width (m)	3.65	3.65
E = Entry width (m)	4.00	4.00
L = Effective length of flare (m)	10	10
R = Entry radius (m)	100	45
D = Inscribed circle diameter (m)	25	25
A = Entry angle (degree)	10	15
Q = Entry flow (pcu/h)	410	300
Qc = Circulating flow across entry (pcu/h)	10	20
OUTPUT PARAMETERS:		
S = Sharpness of flare = 1.6(E-V)/L	0.06	0.06
K = 1-0.00347(A-30)-0.978(1/R-0.05)	1.11	1.08
X2 = $V + ((E-V)/(1+2S))$	3.96	3.96
M = $EXP((D-60)/10)$	0.03	0.03
F = 303*X2	1201	1201
Td = 1+(0.5/(1+M))	1.49	1.49
Fc = 0.21*Td(1+0.2*X2)	0.56	0.56
Qe = K(F-Fc*Qc)	1325	1284
DFC = Design flow/Capacity = Q/Qe	0.31	0.24
Total In Sum =		710 PCU
DFC of Critical Approach =		0.31

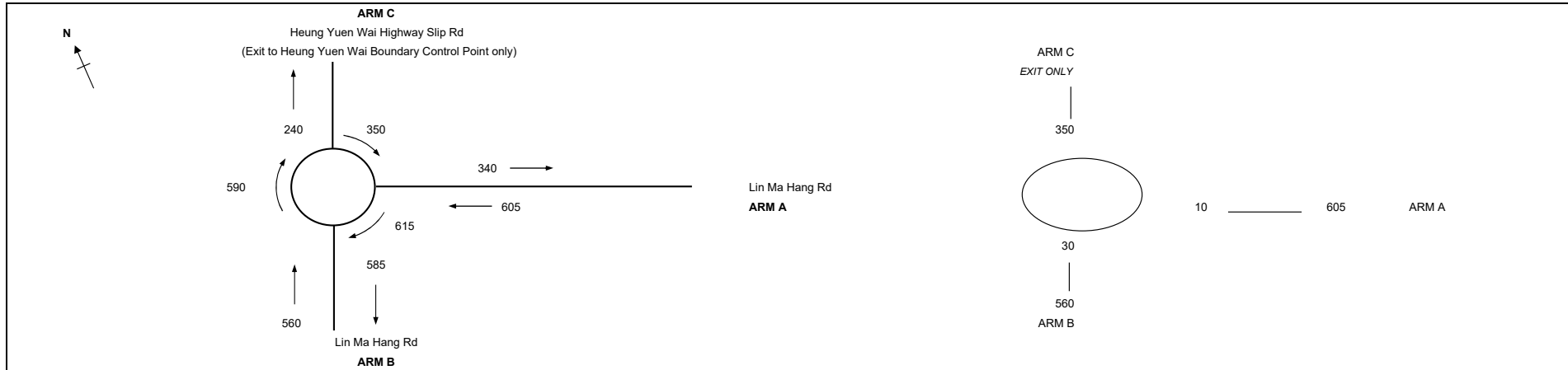

ARM	A	B
INPUT PARAMETERS:		
V = Approach half width (m)	3.65	3.65
E = Entry width (m)	4.00	4.00
L = Effective length of flare (m)	10	10
R = Entry radius (m)	100	45
D = Inscribed circle diameter (m)	25	25
A = Entry angle (degree)	10	15
Q = Entry flow (pcu/h)	605	560
Qc = Circulating flow across entry (pcu/h)	10	30
OUTPUT PARAMETERS:		
S = Sharpness of flare = 1.6(E-V)/L	0.06	0.06
K = 1-0.00347(A-30)-0.978(1/R-0.05)	1.11	1.08
X2 = V + ((E-V)/(1+2S))	3.96	3.96
M = EXP((D-60)/10)	0.03	0.03
F = 303*X2	1201	1201
Td = 1+(0.5/(1+M))	1.49	1.49
Fc = 0.21*Td(1+0.2*X2)	0.56	0.56
Qe = K(F-Fc*Qc)	1325	1278
DFC = Design flow/Capacity = Q/Qe	0.46	0.44
Total In Sum =		1165 PCU
DFC of Critical Approach =		0.46

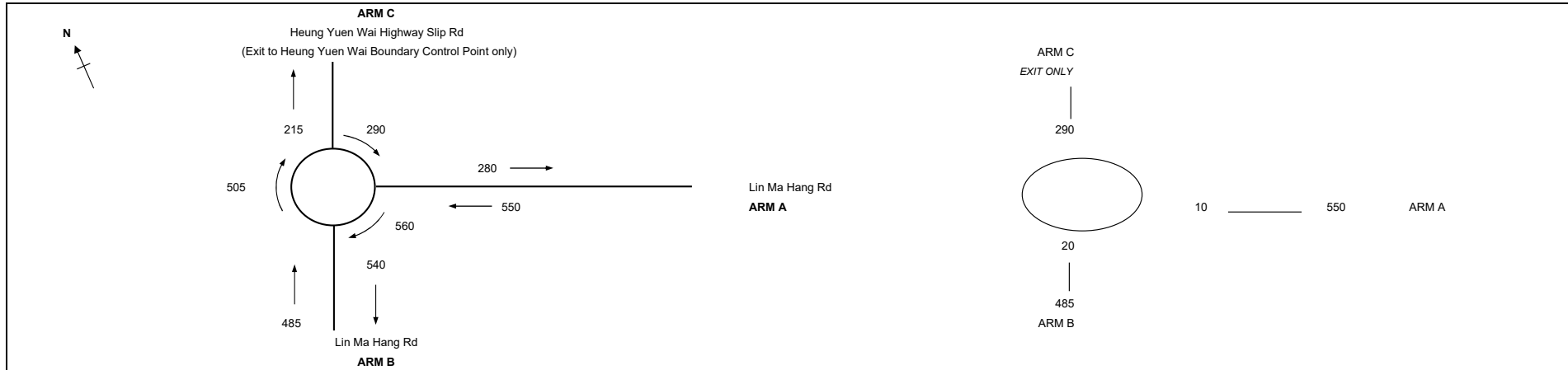

ARM	A	B
INPUT PARAMETERS:		
V = Approach half width (m)	3.65	3.65
E = Entry width (m)	4.00	4.00
L = Effective length of flare (m)	10	10
R = Entry radius (m)	100	45
D = Inscribed circle diameter (m)	25	25
A = Entry angle (degree)	10	15
Q = Entry flow (pcu/h)	550	485
Qc = Circulating flow across entry (pcu/h)	10	20
OUTPUT PARAMETERS:		
S = Sharpness of flare = $1.6(E-V)/L$	0.06	0.06
K = $1-0.00347(A-30)-0.978(1/R-0.05)$	1.11	1.08
X2 = $V + ((E-V)/(1+2S))$	3.96	3.96
M = $EXP((D-60)/10)$	0.03	0.03
F = $303 \times X2$	1201	1201
Td = $1+(0.5/(1+M))$	1.49	1.49
Fc = $0.21 \times Td(1+0.2 \times X2)$	0.56	0.56
Qe = $K(F-Fc \times Qc)$	1325	1284
DFC = Design flow/Capacity = Q/Qe	0.42	0.38
Total In Sum =		1035 PCU
DFC of Critical Approach =		0.42

PROJECT NO: 287082 DESIGNED BY:

J4 - Lin Ma Hang Road / Heung Yuen Wai Highway Slip Road

J4_2023_EXT_AM

DATE : 16/12/2024 FILENAME :

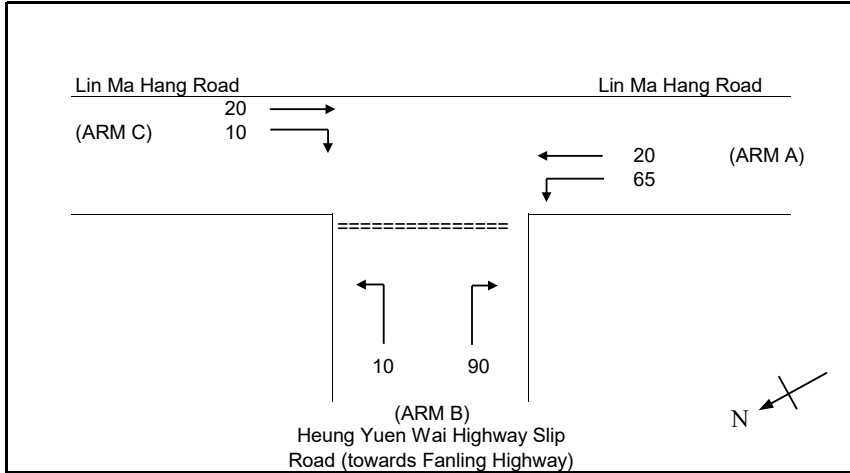

NOTES : (GEOMETRIC INPUT DATA)

- W = MAJOR ROAD WIDTH (6-20m) (minor road turn left only, 2W)
- W cr = CENTRAL RESERVE WIDTH (0m, 1.2-9m)
- W b-a = LANE WIDTH AVAILABLE TO VEHICLE WAITING IN STREAM b-a (0m, 2.2-5m)
- W b-c = LANE WIDTH AVAILABLE TO VEHICLE WAITING IN STREAM b-c (2.2-5m)
- W c-b = LANE WIDTH AVAILABLE TO VEHICLE WAITING IN STREAM c-b (0m, 2.2-5m)
- VI b-a = VISIBILITY TO THE LEFT FOR VEHICLES WAITING IN STREAM b-a (0-250m)
- Vr b-a = VISIBILITY TO THE RIGHT FOR VEHICLES WAITING IN STREAM b-a (0-250)
- Vr b-c = VISIBILITY TO THE RIGHT FOR VEHICLES WAITING IN STREAM b-c (0-250)
- Vr c-b = VISIBILITY TO THE RIGHT FOR VEHICLES WAITING IN STREAM c-b (0-250)
- D = STREAM-SPECIFIC B-A
- E = STREAM-SPECIFIC B-C
- F = STREAM-SPECIFIC C-B
- Y = (1-0.0345W)

GEOMETRIC DETAILS:

MAJOR ROAD (ARM A)
 W = 7.30 (metres)
 W cr = 0.00 (metres)
 q a-b = 65 (pcu/hr)
 q a-c = 20 (pcu/hr)

MAJOR ROAD (ARM C)
 W c-b = 3.65 (metres)
 Vr c-b = 50 (metres)
 q c-a = 20 (pcu/hr)
 q c-b = 10 (pcu/hr)

MINOR ROAD (ARM B)
 W b-a = 5.00 (metres)
 W b-c = 5.00 (metres)
 VI b-a = 100 (metres)
 Vr b-a = 100 (metres)
 Vr b-c = 100 (metres)
 q b-a = 90 (pcu/hr)
 q b-c = 10 (pcu/hr)

GEOMETRIC FACTORS :

D = 1.07
 E = 1.11
 F = 0.94
 Y = 0.75

THE CAPACITY OF MOVEMENT :

Q b-a = 652
 Q b-c = 811
 Q c-b = 676
 Q b-ac = 665

TOTAL FLOW = 215 (PCU/HR)

COMPARISON OF DESIGN FLOW TO CAPACITY:

DFC b-a = 0.14
 DFC b-c = 0.01
 DFC c-b = 0.01
 DFC b-ac = 0.15

CRITICAL DFC = 0.15

PROJECT NO: 287082 DESIGNED BY:

J4 - Lin Ma Hang Road / Heung Yuen Wai Highway Slip Road

J4_2023_EXT_PM

DATE : 16/12/2024 FILENAME :

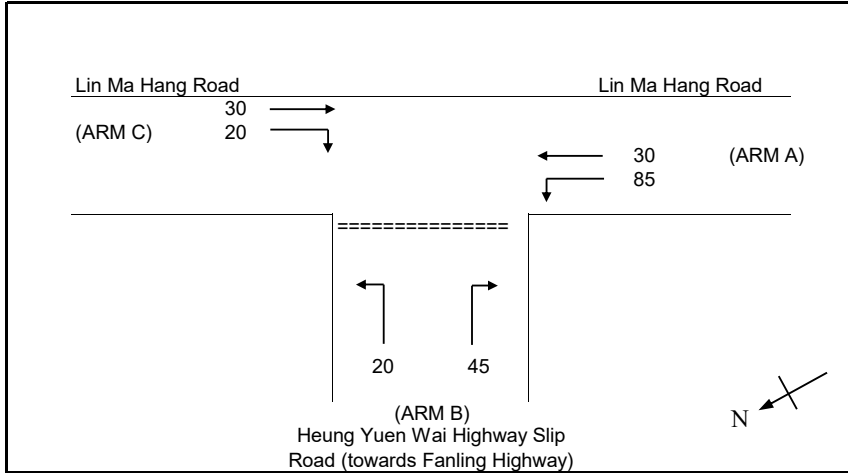

NOTES : (GEOMETRIC INPUT DATA)

- W = MAJOR ROAD WIDTH (6-20m) (minor road turn left only, 2W)
- W cr = CENTRAL RESERVE WIDTH (0m, 1.2-9m)
- W b-a = LANE WIDTH AVAILABLE TO VEHICLE WAITING IN STREAM b-a (0m, 2.2-5m)
- W b-c = LANE WIDTH AVAILABLE TO VEHICLE WAITING IN STREAM b-c (2.2-5m)
- W c-b = LANE WIDTH AVAILABLE TO VEHICLE WAITING IN STREAM c-b (0m, 2.2-5m)
- VI b-a = VISIBILITY TO THE LEFT FOR VEHICLES WAITING IN STREAM b-a (0-250m)
- Vr b-a = VISIBILITY TO THE RIGHT FOR VEHICLES WAITING IN STREAM b-a (0-250)
- Vr b-c = VISIBILITY TO THE RIGHT FOR VEHICLES WAITING IN STREAM b-c (0-250)
- Vr c-b = VISIBILITY TO THE RIGHT FOR VEHICLES WAITING IN STREAM c-b (0-250)
- D = STREAM-SPECIFIC B-A
- E = STREAM-SPECIFIC B-C
- F = STREAM-SPECIFIC C-B
- Y = (1-0.0345W)

GEOMETRIC DETAILS:

MAJOR ROAD (ARM A)
 W = 7.30 (metres)
 W cr = 0.00 (metres)
 q a-b = 85 (pcu/hr)
 q a-c = 30 (pcu/hr)

MAJOR ROAD (ARM C)
 W c-b = 3.65 (metres)
 Vr c-b = 50 (metres)
 q c-a = 30 (pcu/hr)
 q c-b = 20 (pcu/hr)

MINOR ROAD (ARM B)
 W b-a = 5.00 (metres)
 W b-c = 5.00 (metres)
 VI b-a = 100 (metres)
 Vr b-a = 100 (metres)
 Vr b-c = 100 (metres)
 q b-a = 45 (pcu/hr)
 q b-c = 20 (pcu/hr)

GEOMETRIC FACTORS :

D = 1.07
 E = 1.11
 F = 0.94
 Y = 0.75

THE CAPACITY OF MOVEMENT :

Q b-a = 641
 Q b-c = 805
 Q c-b = 669
 Q b-ac = 684

TOTAL FLOW = 230 (PCU/HR)

COMPARISON OF DESIGN FLOW TO CAPACITY:

DFC b-a = 0.07
 DFC b-c = 0.02
 DFC c-b = 0.03
 DFC b-ac = 0.10

CRITICAL DFC = 0.10

PROJECT NO: 287082 DESIGNED BY:

J4 - Lin Ma Hang Road / Heung Yuen Wai Highway Slip Road

J4_2031_REF_AM

DATE : 16/12/2024 FILENAME :

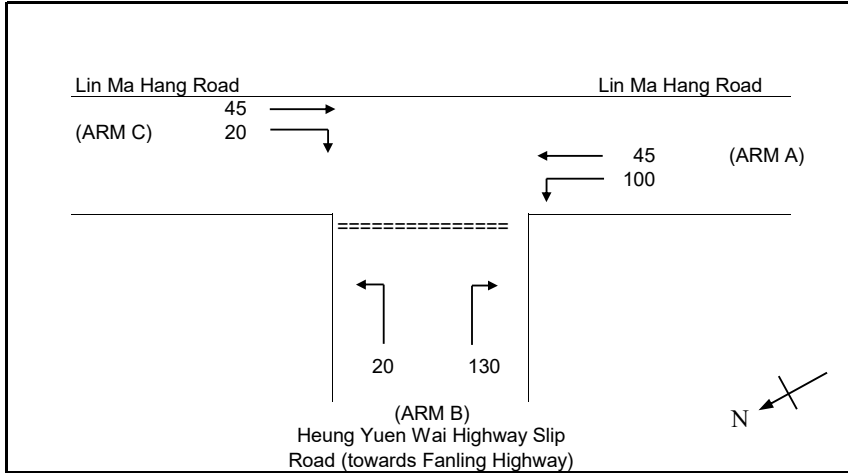

NOTES : (GEOMETRIC INPUT DATA)

- W = MAJOR ROAD WIDTH (6-20m) (minor road turn left only, 2W)
- W cr = CENTRAL RESERVE WIDTH (0m, 1.2-9m)
- W b-a = LANE WIDTH AVAILABLE TO VEHICLE WAITING IN STREAM b-a (0m, 2.2-5m)
- W b-c = LANE WIDTH AVAILABLE TO VEHICLE WAITING IN STREAM b-c (2.2-5m)
- W c-b = LANE WIDTH AVAILABLE TO VEHICLE WAITING IN STREAM c-b (0m, 2.2-5m)
- VI b-a = VISIBILITY TO THE LEFT FOR VEHICLES WAITING IN STREAM b-a (0-250m)
- Vr b-a = VISIBILITY TO THE RIGHT FOR VEHICLES WAITING IN STREAM b-a (0-250)
- Vr b-c = VISIBILITY TO THE RIGHT FOR VEHICLES WAITING IN STREAM b-c (0-250)
- Vr c-b = VISIBILITY TO THE RIGHT FOR VEHICLES WAITING IN STREAM c-b (0-250)
- D = STREAM-SPECIFIC B-A
- E = STREAM-SPECIFIC B-C
- F = STREAM-SPECIFIC C-B
- Y = (1-0.0345W)

GEOMETRIC DETAILS:

MAJOR ROAD (ARM A)
 W = 7.30 (metres)
 W cr = 0.00 (metres)
 q a-b = 100 (pcu/hr)
 q a-c = 45 (pcu/hr)

MAJOR ROAD (ARM C)
 W c-b = 3.65 (metres)
 Vr c-b = 50 (metres)
 q c-a = 45 (pcu/hr)
 q c-b = 20 (pcu/hr)

MINOR ROAD (ARM B)
 W b-a = 5.00 (metres)
 W b-c = 5.00 (metres)
 VI b-a = 100 (metres)
 Vr b-a = 100 (metres)
 Vr b-c = 100 (metres)
 q b-a = 130 (pcu/hr)
 q b-c = 20 (pcu/hr)

GEOMETRIC FACTORS :

D = 1.07
 E = 1.11
 F = 0.94
 Y = 0.75

THE CAPACITY OF MOVEMENT :

Q b-a = 632
 Q b-c = 799
 Q c-b = 661
 Q b-ac = 650

TOTAL FLOW = 360 (PCU/HR)

COMPARISON OF DESIGN FLOW TO CAPACITY:

DFC b-a = 0.21
 DFC b-c = 0.03
 DFC c-b = 0.04
 DFC b-ac = 0.24

CRITICAL DFC = 0.24

PROJECT NO: 287082 DESIGNED BY:

J4 - Lin Ma Hang Road / Heung Yuen Wai Highway Slip Road

J4_2031_REF_PM

DATE : 16/12/2024 FILENAME :

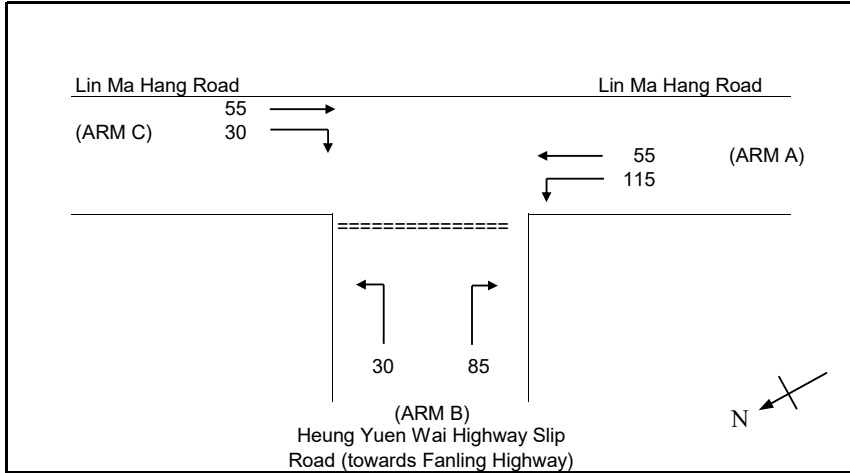

NOTES : (GEOMETRIC INPUT DATA)

- W = MAJOR ROAD WIDTH (6-20m) (minor road turn left only, 2W)
- W cr = CENTRAL RESERVE WIDTH (0m, 1.2-9m)
- W b-a = LANE WIDTH AVAILABLE TO VEHICLE WAITING IN STREAM b-a (0m, 2.2-5m)
- W b-c = LANE WIDTH AVAILABLE TO VEHICLE WAITING IN STREAM b-c (2.2-5m)
- W c-b = LANE WIDTH AVAILABLE TO VEHICLE WAITING IN STREAM c-b (0m, 2.2-5m)
- VI b-a = VISIBILITY TO THE LEFT FOR VEHICLES WAITING IN STREAM b-a (0-250m)
- Vr b-a = VISIBILITY TO THE RIGHT FOR VEHICLES WAITING IN STREAM b-a (0-250)
- Vr b-c = VISIBILITY TO THE RIGHT FOR VEHICLES WAITING IN STREAM b-c (0-250)
- Vr c-b = VISIBILITY TO THE RIGHT FOR VEHICLES WAITING IN STREAM c-b (0-250)
- D = STREAM-SPECIFIC B-A
- E = STREAM-SPECIFIC B-C
- F = STREAM-SPECIFIC C-B
- Y = (1-0.0345W)

GEOMETRIC DETAILS:

MAJOR ROAD (ARM A)
 W = 7.30 (metres)
 W cr = 0.00 (metres)
 q a-b = 115 (pcu/hr)
 q a-c = 55 (pcu/hr)

MAJOR ROAD (ARM C)
 W c-b = 3.65 (metres)
 Vr c-b = 50 (metres)
 q c-a = 55 (pcu/hr)
 q c-b = 30 (pcu/hr)

MINOR ROAD (ARM B)
 W b-a = 5.00 (metres)
 W b-c = 5.00 (metres)
 VI b-a = 100 (metres)
 Vr b-a = 100 (metres)
 Vr b-c = 100 (metres)
 q b-a = 85 (pcu/hr)
 q b-c = 30 (pcu/hr)

GEOMETRIC FACTORS :

D = 1.07
 E = 1.11
 F = 0.94
 Y = 0.75

THE CAPACITY OF MOVEMENT :

Q b-a = 621
 Q b-c = 794
 Q c-b = 655
 Q b-ac = 658

TOTAL FLOW = 370 (PCU/HR)

COMPARISON OF DESIGN FLOW TO CAPACITY:

DFC b-a = 0.14
 DFC b-c = 0.04
 DFC c-b = 0.05
 DFC b-ac = 0.18

CRITICAL DFC = 0.18

PROJECT NO: 287082 DESIGNED BY:

J4 - Lin Ma Hang Road / Heung Yuen Wai Highway Slip Road

J4_2031_DES_AM

DATE : 16/12/2024 FILENAME :

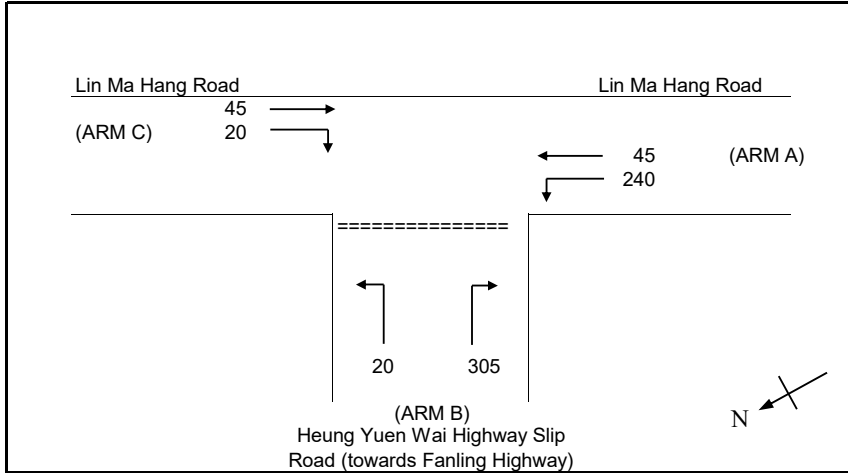

NOTES : (GEOMETRIC INPUT DATA)

- W = MAJOR ROAD WIDTH (6-20m) (minor road turn left only, 2W)
- W cr = CENTRAL RESERVE WIDTH (0m, 1.2-9m)
- W b-a = LANE WIDTH AVAILABLE TO VEHICLE WAITING IN STREAM b-a (0m, 2.2-5m)
- W b-c = LANE WIDTH AVAILABLE TO VEHICLE WAITING IN STREAM b-c (2.2-5m)
- W c-b = LANE WIDTH AVAILABLE TO VEHICLE WAITING IN STREAM c-b (0m, 2.2-5m)
- VI b-a = VISIBILITY TO THE LEFT FOR VEHICLES WAITING IN STREAM b-a (0-250m)
- Vr b-a = VISIBILITY TO THE RIGHT FOR VEHICLES WAITING IN STREAM b-a (0-250)
- Vr b-c = VISIBILITY TO THE RIGHT FOR VEHICLES WAITING IN STREAM b-c (0-250)
- Vr c-b = VISIBILITY TO THE RIGHT FOR VEHICLES WAITING IN STREAM c-b (0-250)
- D = STREAM-SPECIFIC B-A
- E = STREAM-SPECIFIC B-C
- F = STREAM-SPECIFIC C-B
- Y = (1-0.0345W)

GEOMETRIC DETAILS:

MAJOR ROAD (ARM A)
 W = 7.30 (metres)
 W cr = 0.00 (metres)
 q a-b = 240 (pcu/hr)
 q a-c = 45 (pcu/hr)

MAJOR ROAD (ARM C)
 W c-b = 3.65 (metres)
 Vr c-b = 50 (metres)
 q c-a = 45 (pcu/hr)
 q c-b = 20 (pcu/hr)

MINOR ROAD (ARM B)
 W b-a = 5.00 (metres)
 W b-c = 5.00 (metres)
 VI b-a = 100 (metres)
 Vr b-a = 100 (metres)
 Vr b-c = 100 (metres)
 q b-a = 305 (pcu/hr)
 q b-c = 20 (pcu/hr)

GEOMETRIC FACTORS :

D = 1.07
 E = 1.11
 F = 0.94
 Y = 0.75

THE CAPACITY OF MOVEMENT :

Q b-a = 615
 Q b-c = 782
 Q c-b = 625
 Q b-ac = 623

TOTAL FLOW = 675 (PCU/HR)

COMPARISON OF DESIGN FLOW TO CAPACITY:

DFC b-a = 0.50
 DFC b-c = 0.03
 DFC c-b = 0.04
 DFC b-ac = 0.53

CRITICAL DFC = 0.53

PROJECT NO: 287082 DESIGNED BY:

J4 - Lin Ma Hang Road / Heung Yuen Wai Highway Slip Road

J4_2031_DES_PM

DATE : 16/12/2024 FILENAME :

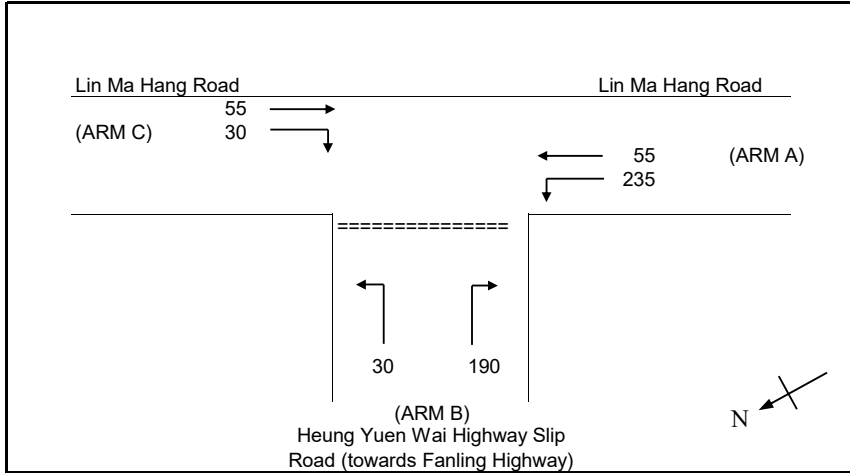

NOTES : (GEOMETRIC INPUT DATA)

- W = MAJOR ROAD WIDTH (6-20m) (minor road turn left only, 2W)
- W cr = CENTRAL RESERVE WIDTH (0m, 1.2-9m)
- W b-a = LANE WIDTH AVAILABLE TO VEHICLE WAITING IN STREAM b-a (0m, 2.2-5m)
- W b-c = LANE WIDTH AVAILABLE TO VEHICLE WAITING IN STREAM b-c (2.2-5m)
- W c-b = LANE WIDTH AVAILABLE TO VEHICLE WAITING IN STREAM c-b (0m, 2.2-5m)
- VI b-a = VISIBILITY TO THE LEFT FOR VEHICLES WAITING IN STREAM b-a (0-250m)
- Vr b-a = VISIBILITY TO THE RIGHT FOR VEHICLES WAITING IN STREAM b-a (0-250)
- Vr b-c = VISIBILITY TO THE RIGHT FOR VEHICLES WAITING IN STREAM b-c (0-250)
- Vr c-b = VISIBILITY TO THE RIGHT FOR VEHICLES WAITING IN STREAM c-b (0-250)
- D = STREAM-SPECIFIC B-A
- E = STREAM-SPECIFIC B-C
- F = STREAM-SPECIFIC C-B
- Y = (1-0.0345W)

GEOMETRIC DETAILS:

MAJOR ROAD (ARM A)
 W = 7.30 (metres)
 W cr = 0.00 (metres)
 q a-b = 235 (pcu/hr)
 q a-c = 55 (pcu/hr)

MAJOR ROAD (ARM C)
 W c-b = 3.65 (metres)
 Vr c-b = 50 (metres)
 q c-a = 55 (pcu/hr)
 q c-b = 30 (pcu/hr)

MINOR ROAD (ARM B)
 W b-a = 5.00 (metres)
 W b-c = 5.00 (metres)
 VI b-a = 100 (metres)
 Vr b-a = 100 (metres)
 Vr b-c = 100 (metres)
 q b-a = 190 (pcu/hr)
 q b-c = 30 (pcu/hr)

GEOMETRIC FACTORS :

D = 1.07
 E = 1.11
 F = 0.94
 Y = 0.75

THE CAPACITY OF MOVEMENT :

Q b-a = 607
 Q b-c = 780
 Q c-b = 624
 Q b-ac = 626

TOTAL FLOW = 595 (PCU/HR)

COMPARISON OF DESIGN FLOW TO CAPACITY:

DFC b-a = 0.32
 DFC b-c = 0.04
 DFC c-b = 0.05
 DFC b-ac = 0.36

CRITICAL DFC = 0.36

J5 - Sha Tau Kok Road / Ping Che Road

J5_2023_EXT_AM

DATE 16/12/2024

PROJECT NO. 287082

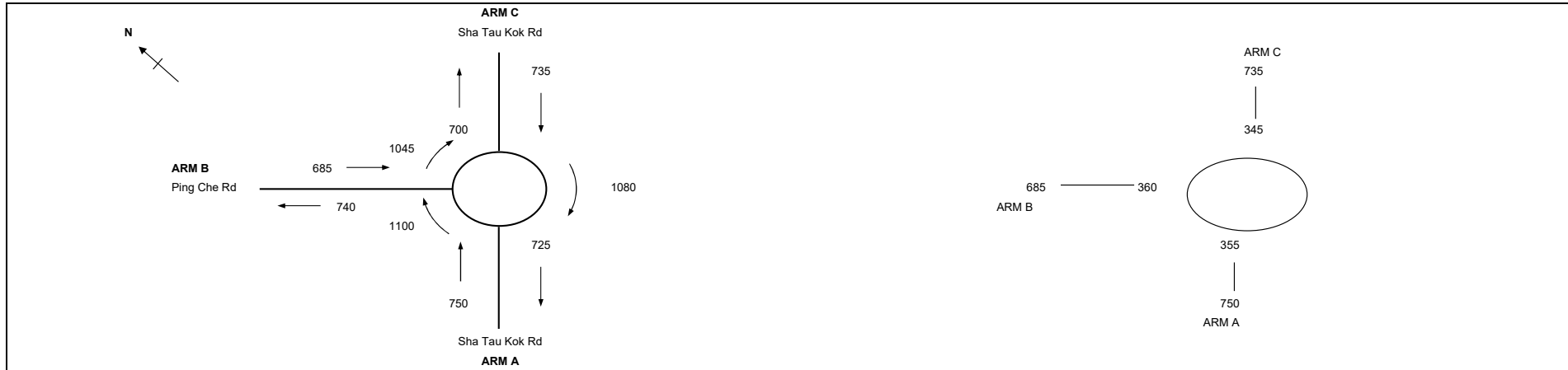

ARM	A	B	C
INPUT PARAMETERS:			
V = Approach half width (m)	7.30	5.50	7.30
E = Entry width (m)	9.00	8.50	9.00
L = Effective length of flare (m)	5	5	5
R = Entry radius (m)	40	15	40
D = Inscribed circle diameter (m)	50	50	50
A = Entry angle (degree)	20	40	25
Q = Entry flow (pcu/h)	750	685	735
Qc = Circulating flow across entry (pcu/h)	355	360	345
OUTPUT PARAMETERS:			
S = Sharpness of flare = 1.6(E-V)/L	0.54	0.96	0.54
K = 1-0.00347(A-30)-0.978(1/R-0.05)	1.06	0.95	1.04
X2 = V + ((E-V)/(1+2S))	8.11	6.53	8.11
M = EXP((D-60)/10)	0.37	0.37	0.37
F = 303*X2	2459	1978	2459
Td = 1+(0.5/(1+M))	1.37	1.37	1.37
Fc = 0.21*Td(1+0.2*X2)	0.75	0.66	0.75
Qe = K(F-Fc*Qc)	2321	1651	2291
DFC = Design flow/Capacity = Q/Qe	0.32	0.41	0.32
Total In Sum =			2170 PCU
DFC of Critical Approach =			0.41

J5 - Sha Tau Kok Road / Ping Che Road

J5_2023_EXT_PM

DATE 16/12/2024

PROJECT NO. 287082

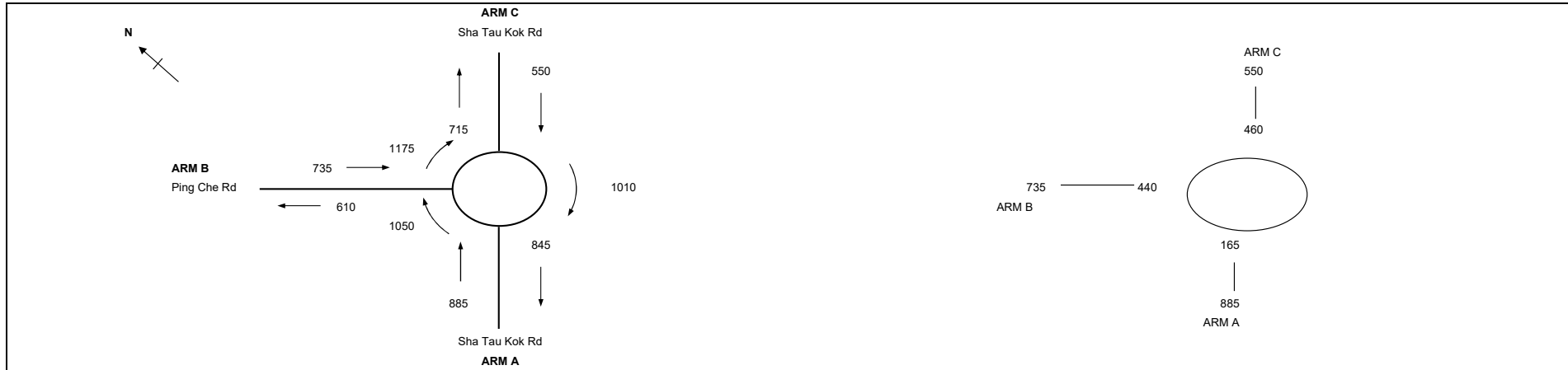

ARM	A	B	C
INPUT PARAMETERS:			
V = Approach half width (m)	7.30	5.50	7.30
E = Entry width (m)	9.00	8.50	9.00
L = Effective length of flare (m)	5	5	5
R = Entry radius (m)	40	15	40
D = Inscribed circle diameter (m)	50	50	50
A = Entry angle (degree)	20	40	25
Q = Entry flow (pcu/h)	885	735	550
Qc = Circulating flow across entry (pcu/h)	165	440	460
OUTPUT PARAMETERS:			
S = Sharpness of flare = 1.6(E-V)/L	0.54	0.96	0.54
K = 1-0.00347(A-30)-0.978(1/R-0.05)	1.06	0.95	1.04
X2 = V + ((E-V)/(1+2S))	8.11	6.53	8.11
M = EXP((D-60)/10)	0.37	0.37	0.37
F = 303*X2	2459	1978	2459
Td = 1+(0.5/(1+M))	1.37	1.37	1.37
Fc = 0.21*Td(1+0.2*X2)	0.75	0.66	0.75
Qe = K(F-Fc*Qc)	2473	1601	2201
DFC = Design flow/Capacity = Q/Qe	0.36	0.46	0.25
		Total In Sum =	2170 PCU
		DFC of Critical Approach =	0.46

J5 - Sha Tau Kok Road / Ping Che Road

J5_2031_REF_AM

DATE 16/12/2024

PROJECT NO. 287082

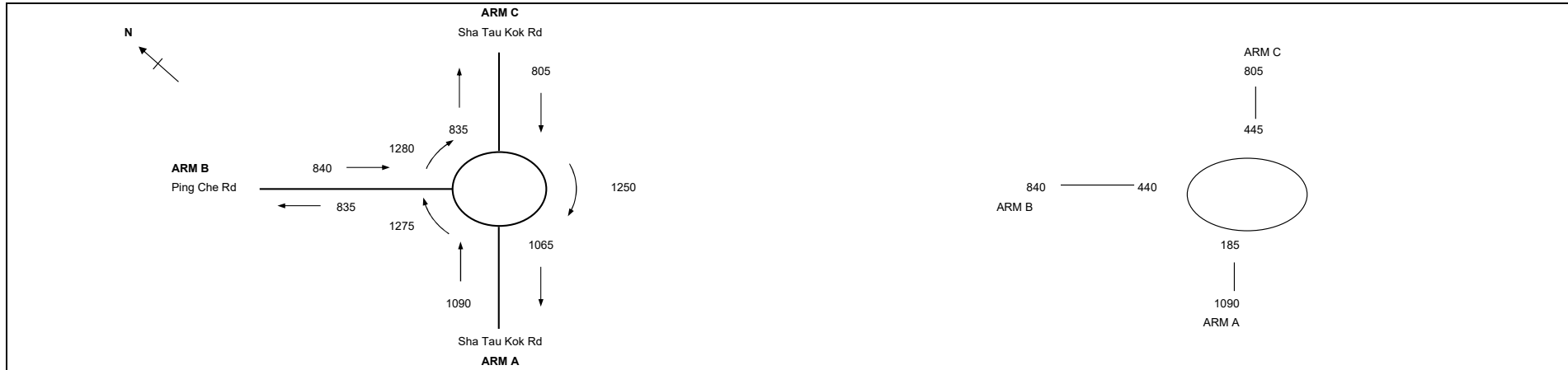

ARM	A	B	C		
INPUT PARAMETERS:					
V =	Approach half width (m)	7.30	5.50	7.30	
E =	Entry width (m)	9.00	8.50	9.00	
L =	Effective length of flare (m)	5	5	5	
R =	Entry radius (m)	40	15	40	
D =	Inscribed circle diameter (m)	50	50	50	
A =	Entry angle (degree)	20	40	25	
Q =	Entry flow (pcu/h)	1090	840	805	
Qc =	Circulating flow across entry (pcu/h)	185	440	445	
OUTPUT PARAMETERS:					
S =	Sharpness of flare = $1.6(E-V)/L$	0.54	0.96	0.54	
K =	$1-0.00347(A-30)-0.978(1/R-0.05)$	1.06	0.95	1.04	
X2 =	$V + ((E-V)/(1+2S))$	8.11	6.53	8.11	
M =	$EXP((D-60)/10)$	0.37	0.37	0.37	
F =	$303 \times X2$	2459	1978	2459	
Td =	$1+(0.5/(1+M))$	1.37	1.37	1.37	
Fc =	$0.21 \times Td(1+0.2 \times X2)$	0.75	0.66	0.75	
Qe =	$K(F-Fc \times Qc)$	2457	1601	2213	
DFC =	Design flow/Capacity = Q/Qe	0.45	0.53	0.37	
Total In Sum =					2735 PCU
DFC of Critical Approach =					0.53

J5 - Sha Tau Kok Road / Ping Che Road

J5_2031_REF_PM

DATE 16/12/2024

PROJECT NO. 287082

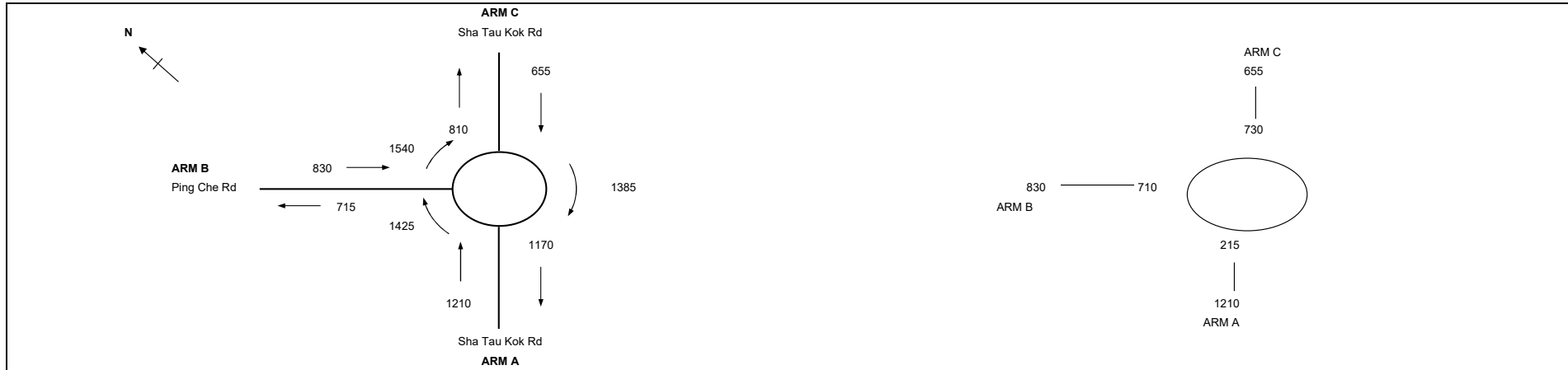

ARM	A	B	C
INPUT PARAMETERS:			
V = Approach half width (m)	7.30	5.50	7.30
E = Entry width (m)	9.00	8.50	9.00
L = Effective length of flare (m)	5	5	5
R = Entry radius (m)	40	15	40
D = Inscribed circle diameter (m)	50	50	50
A = Entry angle (degree)	20	40	25
Q = Entry flow (pcu/h)	1210	830	655
Qc = Circulating flow across entry (pcu/h)	215	710	730
OUTPUT PARAMETERS:			
S = Sharpness of flare = 1.6(E-V)/L	0.54	0.96	0.54
K = 1-0.00347(A-30)-0.978(1/R-0.05)	1.06	0.95	1.04
X2 = V + ((E-V)/(1+2S))	8.11	6.53	8.11
M = EXP((D-60)/10)	0.37	0.37	0.37
F = 303*X2	2459	1978	2459
Td = 1+(0.5/(1+M))	1.37	1.37	1.37
Fc = 0.21*Td(1+0.2*X2)	0.75	0.66	0.75
Qe = K(F-Fc*Qc)	2433	1431	1989
DFC = Design flow/Capacity = Q/Qe	0.50	0.58	0.33
Total In Sum =			2695 PCU
DFC of Critical Approach =			0.58

J5 - Sha Tau Kok Road / Ping Che Road

J5_2031_DES_AM

DATE 16/12/2024

PROJECT NO. 287082

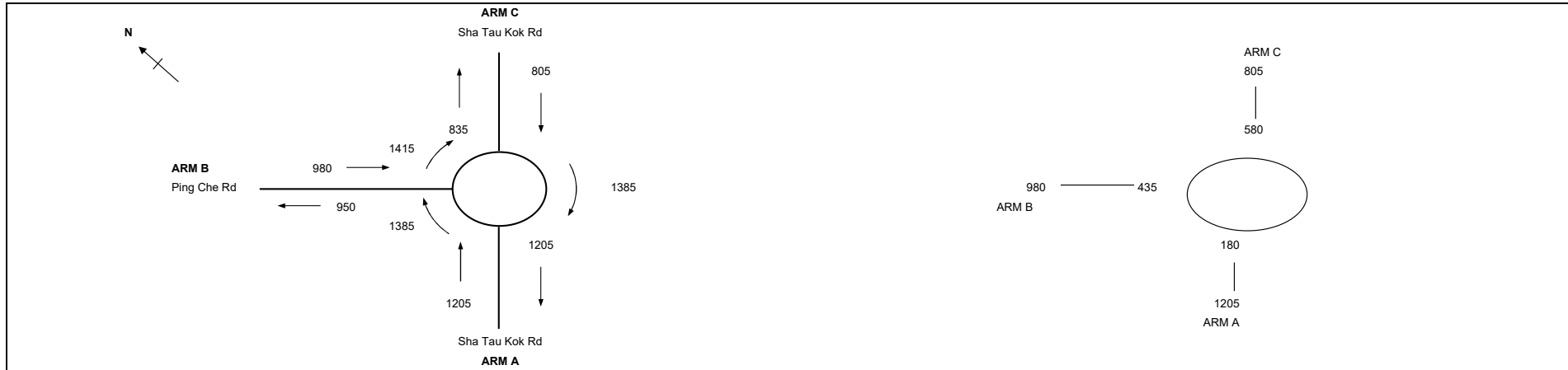

ARM	A	B	C		
INPUT PARAMETERS:					
V = Approach half width (m)	7.30	5.50	7.30		
E = Entry width (m)	9.00	8.50	9.00		
L = Effective length of flare (m)	5	5	5		
R = Entry radius (m)	40	15	40		
D = Inscribed circle diameter (m)	50	50	50		
A = Entry angle (degree)	20	40	25		
Q = Entry flow (pcu/h)	1205	980	805		
Qc = Circulating flow across entry (pcu/h)	180	435	580		
OUTPUT PARAMETERS:					
S = Sharpness of flare = 1.6(E-V)/L	0.54	0.96	0.54		
K = 1-0.00347(A-30)-0.978(1/R-0.05)	1.06	0.95	1.04		
X2 = V + ((E-V)/(1+2S))	8.11	6.53	8.11		
M = EXP((D-60)/10)	0.37	0.37	0.37		
F = 303*X2	2459	1978	2459		
Td = 1+(0.5/(1+M))	1.37	1.37	1.37		
Fc = 0.21*Td(1+0.2*X2)	0.75	0.66	0.75		
Qe = K(F-Fc*Qc)	2461	1604	2107		
DFC = Design flow/Capacity = Q/Qe	0.49	0.62	0.39		
				Total In Sum =	2990 PCU
				DFC of Critical Approach =	0.62

J5 - Sha Tau Kok Road / Ping Che Road

J5_2031_DES_PM

DATE 16/12/2024

PROJECT NO. 287082

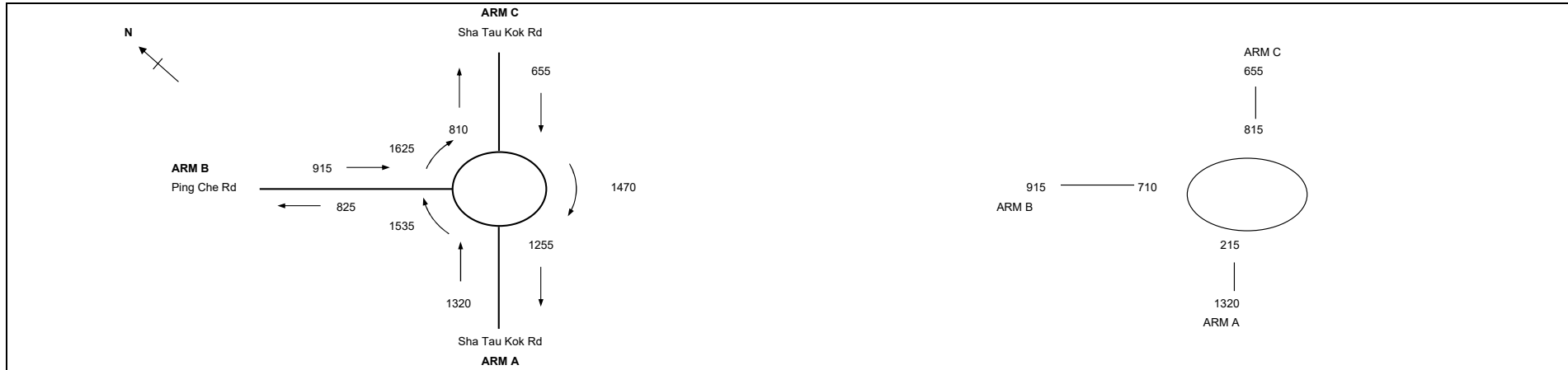

ARM	A	B	C	
INPUT PARAMETERS:				
V =	Approach half width (m)	7.30	5.50	7.30
E =	Entry width (m)	9.00	8.50	9.00
L =	Effective length of flare (m)	5	5	5
R =	Entry radius (m)	40	15	40
D =	Inscribed circle diameter (m)	50	50	50
A =	Entry angle (degree)	20	40	25
Q =	Entry flow (pcu/h)	1320	915	655
Qc =	Circulating flow across entry (pcu/h)	215	710	815
OUTPUT PARAMETERS:				
S =	Sharpness of flare = 1.6(E-V)/L	0.54	0.96	0.54
K =	1-0.00347(A-30)-0.978(1/R-0.05)	1.06	0.95	1.04
X2 =	V + ((E-V)/(1+2S))	8.11	6.53	8.11
M =	EXP((D-60)/10)	0.37	0.37	0.37
F =	303*X2	2459	1978	2459
Td =	1+(0.5/(1+M))	1.37	1.37	1.37
Fc =	0.21*Td(1+0.2*X2)	0.75	0.66	0.75
Qe =	K(F-Fc*Qc)	2433	1431	1923
DFC =	Design flow/Capacity = Q/Qe	0.55	0.64	0.35
Total In Sum =				2890 PCU
DFC of Critical Approach =				0.64

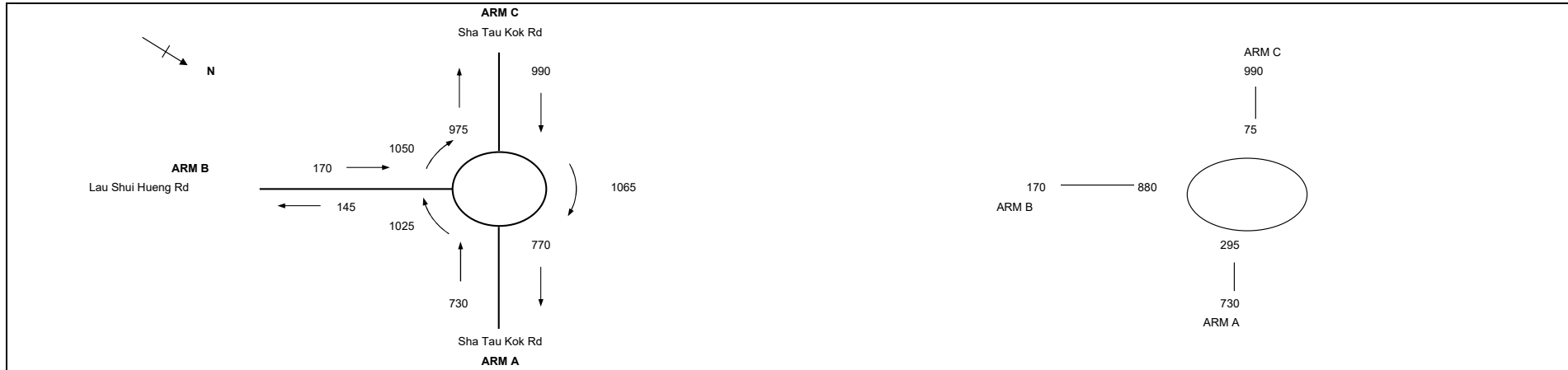

ARM	A	B	C
INPUT PARAMETERS:			
V = Approach half width (m)	7.30	3.30	7.30
E = Entry width (m)	9.00	5.00	9.00
L = Effective length of flare (m)	15	5	15
R = Entry radius (m)	15	80	80
D = Inscribed circle diameter (m)	50	50	50
A = Entry angle (degree)	40	25	10
Q = Entry flow (pcu/h)	730	170	990
Qc = Circulating flow across entry (pcu/h)	295	880	75
OUTPUT PARAMETERS:			
S = Sharpness of flare = $1.6(E-V)/L$	0.18	0.54	0.18
K = $1-0.00347(A-30)-0.978(1/R-0.05)$	0.95	1.05	1.11
X2 = $V + ((E-V)/(1+2S))$	8.55	4.11	8.55
M = $EXP((D-60)/10)$	0.37	0.37	0.37
F = $303 \times X2$	2590	1247	2590
Td = $1+(0.5/(1+M))$	1.37	1.37	1.37
Fc = $0.21 \times Td(1+0.2 \times X2)$	0.78	0.52	0.78
Qe = $K(F-Fc \times Qc)$	2240	829	2800
DFC = Design flow/Capacity = Q/Qe	0.33	0.21	0.35
Total In Sum =		1890	PCU
DFC of Critical Approach =		0.35	

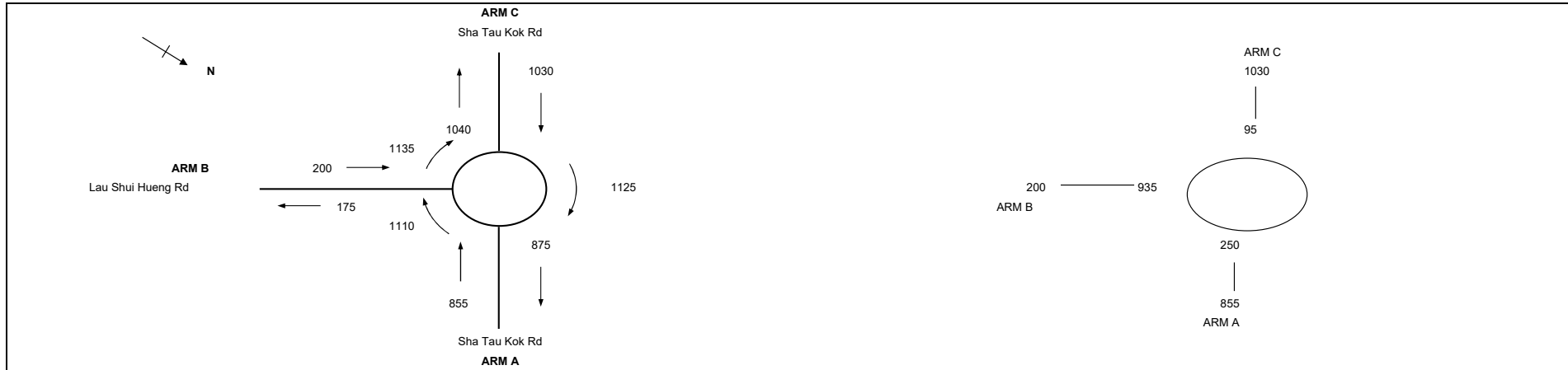

ARM	A	B	C		
INPUT PARAMETERS:					
V	= Approach half width (m)	7.30	3.30	7.30	
E	= Entry width (m)	9.00	5.00	9.00	
L	= Effective length of flare (m)	15	5	15	
R	= Entry radius (m)	15	80	80	
D	= Inscribed circle diameter (m)	50	50	50	
A	= Entry angle (degree)	40	25	10	
Q	= Entry flow (pcu/h)	855	200	1030	
Qc	= Circulating flow across entry (pcu/h)	250	935	95	
OUTPUT PARAMETERS:					
S	= Sharpness of flare = 1.6(E-V)/L	0.18	0.54	0.18	
K	= 1-0.00347(A-30)-0.978(1/R-0.05)	0.95	1.05	1.11	
X2	= V + ((E-V)/(1+2S))	8.55	4.11	8.55	
M	= EXP((D-60)/10)	0.37	0.37	0.37	
F	= 303*X2	2590	1247	2590	
Td	= 1+(0.5/(1+M))	1.37	1.37	1.37	
Fc	= 0.21*Td(1+0.2*X2)	0.78	0.52	0.78	
Qe	= K(F-Fc*Qc)	2273	799	2783	
DFC	= Design flow/Capacity = Q/Qe	0.38	0.25	0.37	
				Total In Sum =	2085 PCU
				DFC of Critical Approach =	0.38

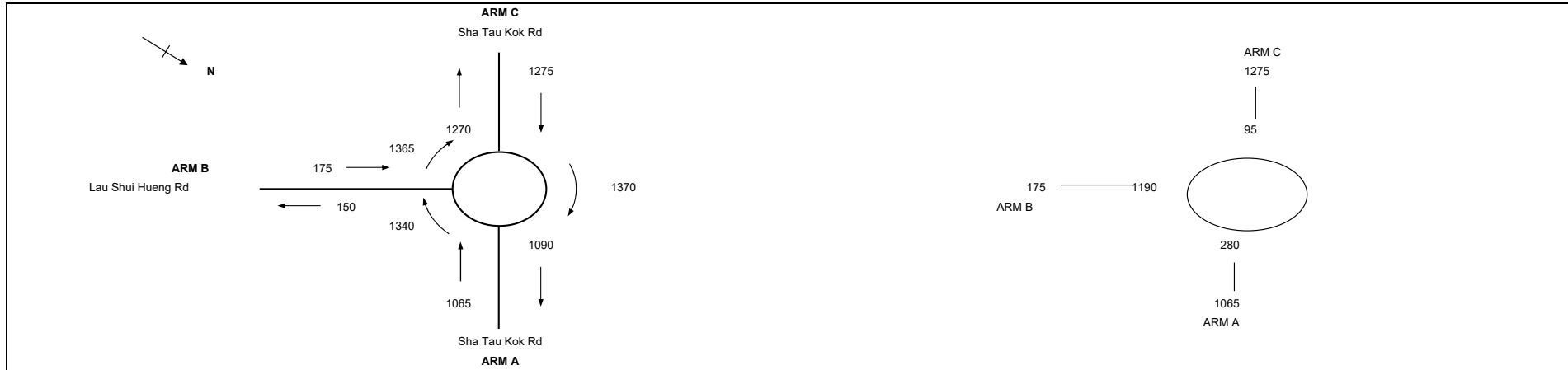

ARM	A	B	C	
INPUT PARAMETERS:				
V =	Approach half width (m)	7.30	3.30	7.30
E =	Entry width (m)	9.00	5.00	9.00
L =	Effective length of flare (m)	15	5	15
R =	Entry radius (m)	15	80	80
D =	Inscribed circle diameter (m)	50	50	50
A =	Entry angle (degree)	40	25	10
Q =	Entry flow (pcu/h)	1065	175	1275
Qc =	Circulating flow across entry (pcu/h)	280	1190	95
OUTPUT PARAMETERS:				
S =	Sharpness of flare = $1.6(E-V)/L$	0.18	0.54	0.18
K =	$1-0.00347(A-30)-0.978(1/R-0.05)$	0.95	1.05	1.11
X2 =	$V + ((E-V)/(1+2S))$	8.55	4.11	8.55
M =	$EXP((D-60)/10)$	0.37	0.37	0.37
F =	$303 \times X2$	2590	1247	2590
Td =	$1+(0.5/(1+M))$	1.37	1.37	1.37
Fc =	$0.21 \times Td(1+0.2 \times X2)$	0.78	0.52	0.78
Qe =	$K(F-Fc \times Qc)$	2251	658	2783
DFC =	Design flow/Capacity = Q/Qe	0.48	0.27	0.46
Total In Sum =				2515 PCU
DFC of Critical Approach =				0.48

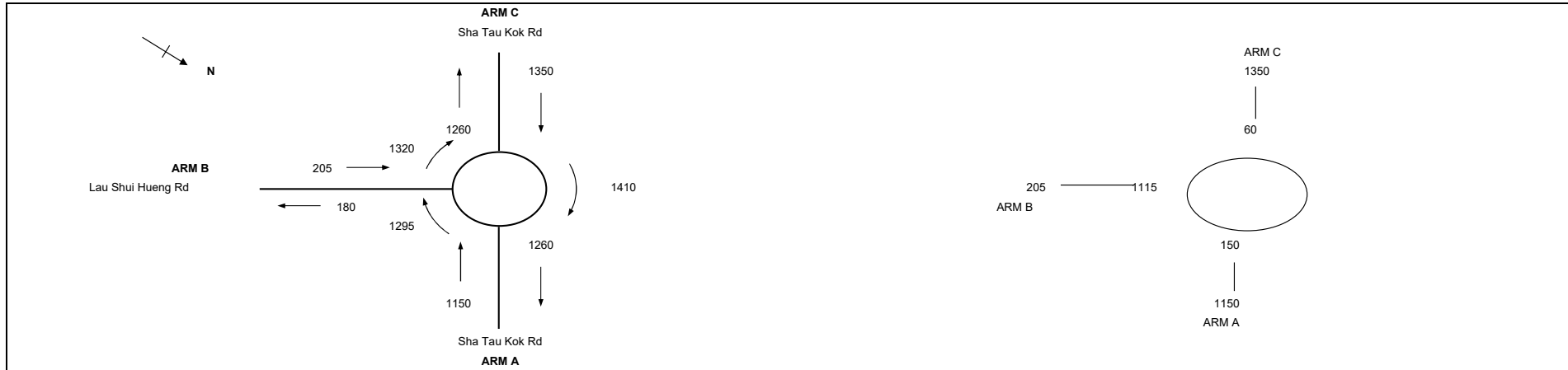

ARM	A	B	C
INPUT PARAMETERS:			
V = Approach half width (m)	7.30	3.30	7.30
E = Entry width (m)	9.00	5.00	9.00
L = Effective length of flare (m)	15	5	15
R = Entry radius (m)	15	80	80
D = Inscribed circle diameter (m)	50	50	50
A = Entry angle (degree)	40	25	10
Q = Entry flow (pcu/h)	1150	205	1350
Qc = Circulating flow across entry (pcu/h)	150	1115	60
OUTPUT PARAMETERS:			
S = Sharpness of flare = $1.6(E-V)/L$	0.18	0.54	0.18
K = $1-0.00347(A-30)-0.978(1/R-0.05)$	0.95	1.05	1.11
X2 = $V + ((E-V)/(1+2S))$	8.55	4.11	8.55
M = $EXP((D-60)/10)$	0.37	0.37	0.37
F = $303 \times X2$	2590	1247	2590
Td = $1+(0.5/(1+M))$	1.37	1.37	1.37
Fc = $0.21 \times Td(1+0.2 \times X2)$	0.78	0.52	0.78
Qe = $K(F-Fc \times Qc)$	2347	700	2813
DFC = Design flow/Capacity = Q/Qe	0.49	0.30	0.48
Total In Sum =		2705	PCU
DFC of Critical Approach =		0.49	

J6 - Sha Tau Kok Road / Lau Shui Heung Road

J6_2031_DES_AM

DATE 16/12/2024

PROJECT NO. 287082

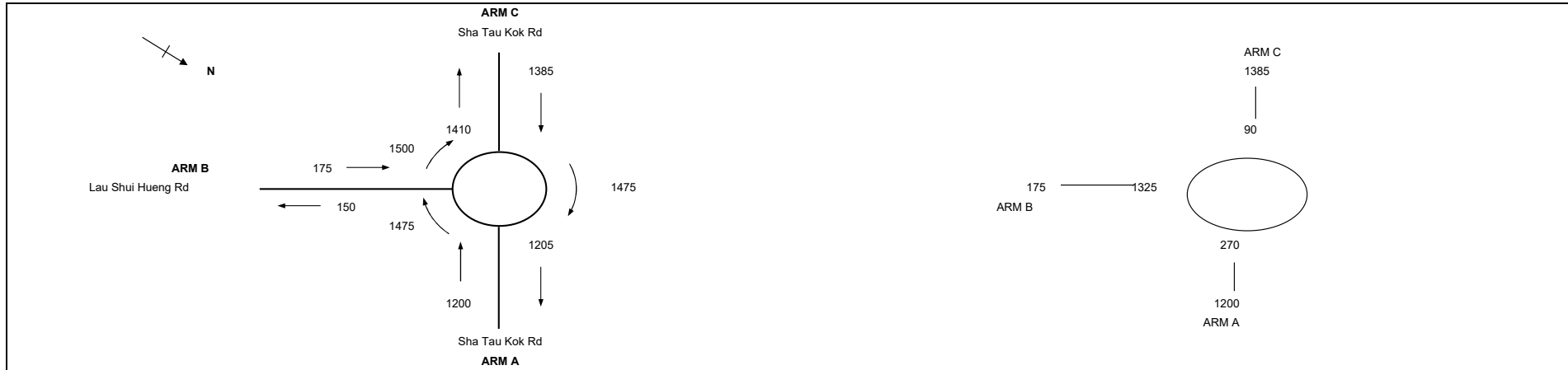

ARM	A	B	C
INPUT PARAMETERS:			
V = Approach half width (m)	7.30	3.30	7.30
E = Entry width (m)	9.00	5.00	9.00
L = Effective length of flare (m)	15	5	15
R = Entry radius (m)	15	80	80
D = Inscribed circle diameter (m)	50	50	50
A = Entry angle (degree)	40	25	10
Q = Entry flow (pcu/h)	1200	175	1385
Qc = Circulating flow across entry (pcu/h)	270	1325	90
OUTPUT PARAMETERS:			
S = Sharpness of flare = $1.6(E-V)/L$	0.18	0.54	0.18
K = $1-0.00347(A-30)-0.978(1/R-0.05)$	0.95	1.05	1.11
X2 = $V + ((E-V)/(1+2S))$	8.55	4.11	8.55
M = $EXP((D-60)/10)$	0.37	0.37	0.37
F = $303 \times X2$	2590	1247	2590
Td = $1+(0.5/(1+M))$	1.37	1.37	1.37
Fc = $0.21 \times Td(1+0.2 \times X2)$	0.78	0.52	0.78
Qe = $K(F-Fc \times Qc)$	2259	584	2787
DFC = Design flow/Capacity = Q/Qe	0.54	0.30	0.50
Total In Sum =		2760	PCU
DFC of Critical Approach =		0.54	



ARM	A	B	C
INPUT PARAMETERS:			
V = Approach half width (m)	7.30	3.30	7.30
E = Entry width (m)	9.00	5.00	9.00
L = Effective length of flare (m)	15	5	15
R = Entry radius (m)	15	80	80
D = Inscribed circle diameter (m)	50	50	50
A = Entry angle (degree)	40	25	10
Q = Entry flow (pcu/h)	1235	205	1455
Qc = Circulating flow across entry (pcu/h)	150	1200	60
OUTPUT PARAMETERS:			
S = Sharpness of flare = 1.6(E-V)/L	0.18	0.54	0.18
K = 1-0.00347(A-30)-0.978(1/R-0.05)	0.95	1.05	1.11
X2 = V + ((E-V)/(1+2S))	8.55	4.11	8.55
M = EXP((D-60)/10)	0.37	0.37	0.37
F = 303*X2	2590	1247	2590
Td = 1+(0.5/(1+M))	1.37	1.37	1.37
Fc = 0.21*Td(1+0.2*X2)	0.78	0.52	0.78
Qe = K(F-Fc*Qc)	2347	653	2813
DFC = Design flow/Capacity = Q/Qe	0.53	0.32	0.52
Total In Sum =			2895 PCU
DFC of Critical Approach =			0.53

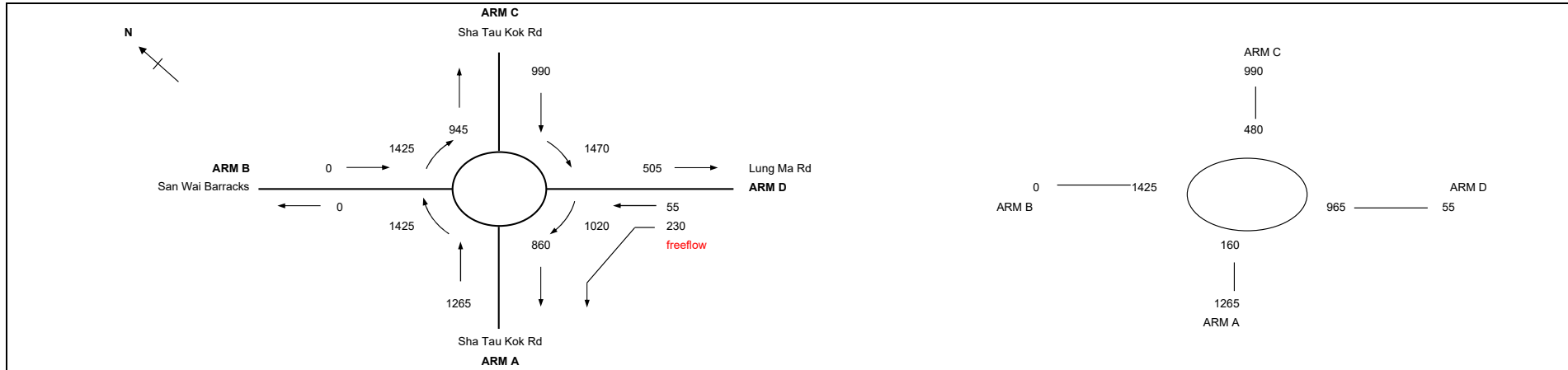

ARM	A	B	C	D
INPUT PARAMETERS:				
V = Approach half width (m)	7.30	3.30	7.30	3.50
E = Entry width (m)	10.00	5.00	10.00	5.00
L = Effective length of flare (m)	20	5	10	5
R = Entry radius (m)	30	60	30	70
D = Inscribed circle diameter (m)	50	50	50	50
A = Entry angle (degree)	15	15	25	15
Q = Entry flow (pcu/h)	1265	0	990	55
Qc = Circulating flow across entry (pcu/h)	160	1425	480	965
OUTPUT PARAMETERS:				
S = Sharpness of flare = 1.6(E-V)/L	0.22	0.54	0.43	0.48
K = 1-0.00347(A-30)-0.978(1/R-0.05)	1.07	1.08	1.03	1.09
X2 = V + ((E-V)/(1+2S))	9.19	4.11	8.75	4.27
M = EXP((D-60)/10)	0.37	0.37	0.37	0.37
F = 303*X2	2783	1247	2651	1292
Td = 1+(0.5/(1+M))	1.37	1.37	1.37	1.37
Fc = 0.21*Td(1+0.2*X2)	0.81	0.52	0.79	0.53
Qe = K(F-Fc*Qc)	2834	544	2349	847
DFC = Design flow/Capacity = Q/Qe	0.45	0.00	0.42	0.06
Total In Sum = 2255 PCU				
DFC of Critical Approach = 0.45				

J7 - Sha Tau Kok Road / Lung Ma Road / San Wai Barracks

J7_2023_EXT_PM

DATE 16/12/2024

PROJECT NO. 287082

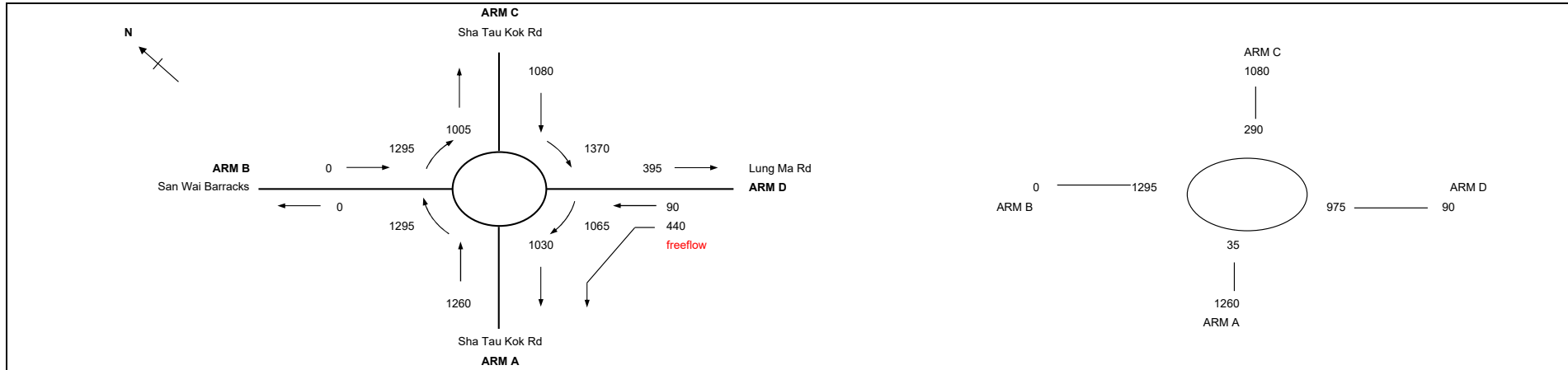

ARM	A	B	C	D
INPUT PARAMETERS:				
V = Approach half width (m)	7.30	3.30	7.30	3.50
E = Entry width (m)	10.00	5.00	10.00	5.00
L = Effective length of flare (m)	20	5	10	5
R = Entry radius (m)	30	60	30	70
D = Inscribed circle diameter (m)	50	50	50	50
A = Entry angle (degree)	15	15	25	15
Q = Entry flow (pcu/h)	1260	0	1080	90
Qc = Circulating flow across entry (pcu/h)	35	1295	290	975
OUTPUT PARAMETERS:				
S = Sharpness of flare = 1.6(E-V)/L	0.22	0.54	0.43	0.48
K = 1-0.00347(A-30)-0.978(1/R-0.05)	1.07	1.08	1.03	1.09
X2 = V + ((E-V)/(1+2S))	9.19	4.11	8.75	4.27
M = EXP((D-60)/10)	0.37	0.37	0.37	0.37
F = 303*X2	2783	1247	2651	1292
Td = 1+(0.5/(1+M))	1.37	1.37	1.37	1.37
Fc = 0.21*Td(1+0.2*X2)	0.81	0.52	0.79	0.53
Qe = K(F-Fc*Qc)	2943	618	2504	842
DFC = Design flow/Capacity = Q/Qe	0.43	0.00	0.43	0.11
Total In Sum = 2340 PCU				
DFC of Critical Approach = 0.43				

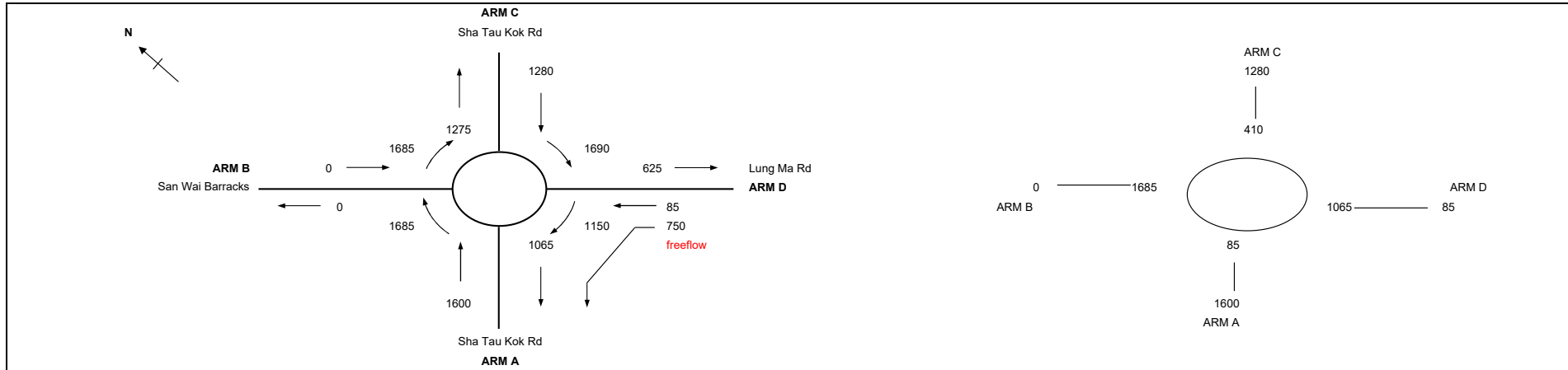

ARM	A	B	C	D
INPUT PARAMETERS:				
V = Approach half width (m)	7.30	3.30	7.30	3.50
E = Entry width (m)	10.00	5.00	10.00	5.00
L = Effective length of flare (m)	20	5	10	5
R = Entry radius (m)	30	60	30	70
D = Inscribed circle diameter (m)	50	50	50	50
A = Entry angle (degree)	15	15	25	15
Q = Entry flow (pcu/h)	1600	0	1280	85
Qc = Circulating flow across entry (pcu/h)	85	1685	410	1065
OUTPUT PARAMETERS:				
S = Sharpness of flare = 1.6(E-V)/L	0.22	0.54	0.43	0.48
K = 1-0.00347(A-30)-0.978(1/R-0.05)	1.07	1.08	1.03	1.09
X2 = V + ((E-V)/(1+2S))	9.19	4.11	8.75	4.27
M = EXP((D-60)/10)	0.37	0.37	0.37	0.37
F = 303*X2	2783	1247	2651	1292
Td = 1+(0.5/(1+M))	1.37	1.37	1.37	1.37
Fc = 0.21*Td(1+0.2*X2)	0.81	0.52	0.79	0.53
Qe = K(F-Fc*Qc)	2900	397	2406	790
DFC = Design flow/Capacity = Q/Qe	0.56	0.00	0.54	0.11
Total In Sum = 2880 PCU				
DFC of Critical Approach = 0.56				

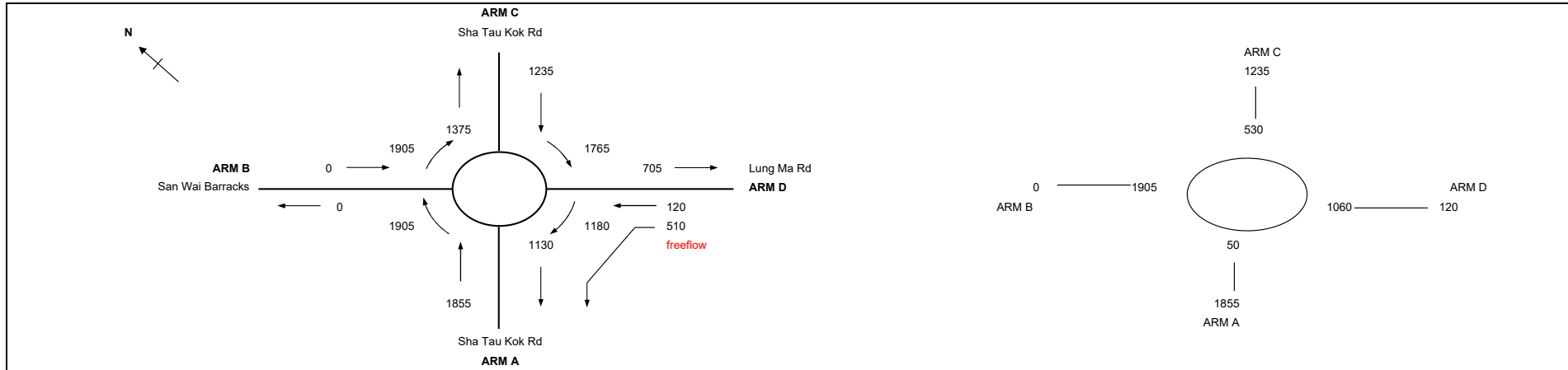

ARM	A	B	C	D		
INPUT PARAMETERS:						
V = Approach half width (m)	7.30	3.30	7.30	3.50		
E = Entry width (m)	10.00	5.00	10.00	5.00		
L = Effective length of flare (m)	20	5	10	5		
R = Entry radius (m)	30	60	30	70		
D = Inscribed circle diameter (m)	50	50	50	50		
A = Entry angle (degree)	15	15	25	15		
Q = Entry flow (pcu/h)	1855	0	1235	120		
Qc = Circulating flow across entry (pcu/h)	50	1905	530	1060		
OUTPUT PARAMETERS:						
S = Sharpness of flare = 1.6(E-V)/L	0.22	0.54	0.43	0.48		
K = 1-0.00347(A-30)-0.978(1/R-0.05)	1.07	1.08	1.03	1.09		
X2 = V + ((E-V)/(1+2S))	9.19	4.11	8.75	4.27		
M = EXP((D-60)/10)	0.37	0.37	0.37	0.37		
F = 303*X2	2783	1247	2651	1292		
Td = 1+(0.5/(1+M))	1.37	1.37	1.37	1.37		
Fc = 0.21*Td(1+0.2*X2)	0.81	0.52	0.79	0.53		
Qe = K(F-Fc*Qc)	2930	272	2308	793		
DFC = Design flow/Capacity = Q/Qe	0.64	0.00	0.54	0.16		
					Total In Sum =	3090 PCU
					DFC of Critical Approach =	0.64

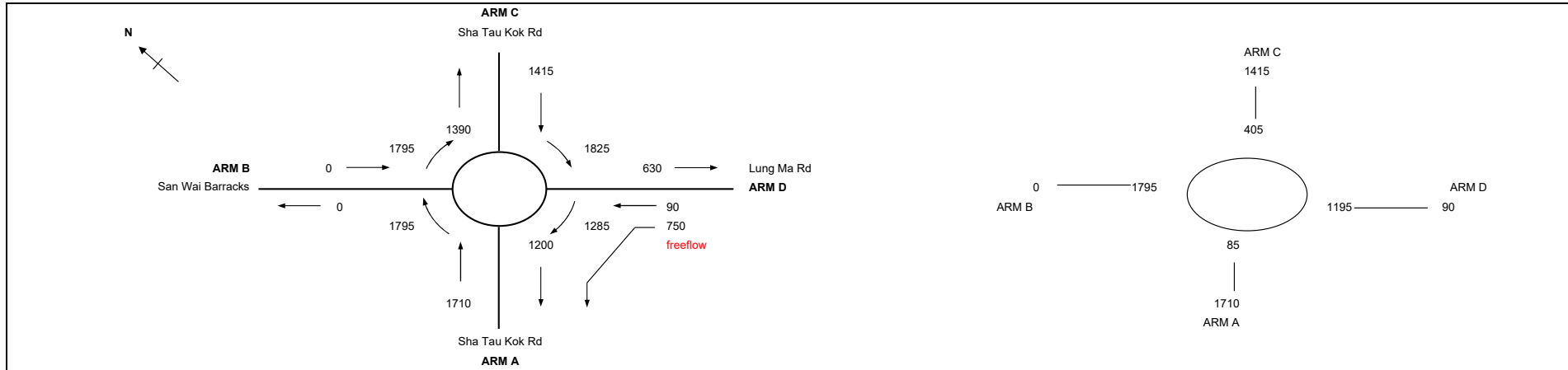

ARM	A	B	C	D		
INPUT PARAMETERS:						
V = Approach half width (m)	7.30	3.30	7.30	3.50		
E = Entry width (m)	10.00	5.00	10.00	5.00		
L = Effective length of flare (m)	20	5	10	5		
R = Entry radius (m)	30	60	30	70		
D = Inscribed circle diameter (m)	50	50	50	50		
A = Entry angle (degree)	15	15	25	15		
Q = Entry flow (pcu/h)	1710	0	1415	90		
Qc = Circulating flow across entry (pcu/h)	85	1795	405	1195		
OUTPUT PARAMETERS:						
S = Sharpness of flare = 1.6(E-V)/L	0.22	0.54	0.43	0.48		
K = 1-0.00347(A-30)-0.978(1/R-0.05)	1.07	1.08	1.03	1.09		
X2 = V + ((E-V)/(1+2S))	9.19	4.11	8.75	4.27		
M = EXP((D-60)/10)	0.37	0.37	0.37	0.37		
F = 303*X2	2783	1247	2651	1292		
Td = 1+(0.5/(1+M))	1.37	1.37	1.37	1.37		
Fc = 0.21*Td(1+0.2*X2)	0.81	0.52	0.79	0.53		
Qe = K(F-Fc*Qc)	2900	334	2410	715	Total In Sum =	3125 PCU
DFC = Design flow/Capacity = Q/Qe	0.59	0.00	0.59	0.13	DFC of Critical Approach =	0.59

J7 - Sha Tau Kok Road / Lung Ma Road / San Wai Barracks

J7_2031_DES_PM

DATE 16/12/2024

PROJECT NO. 287082

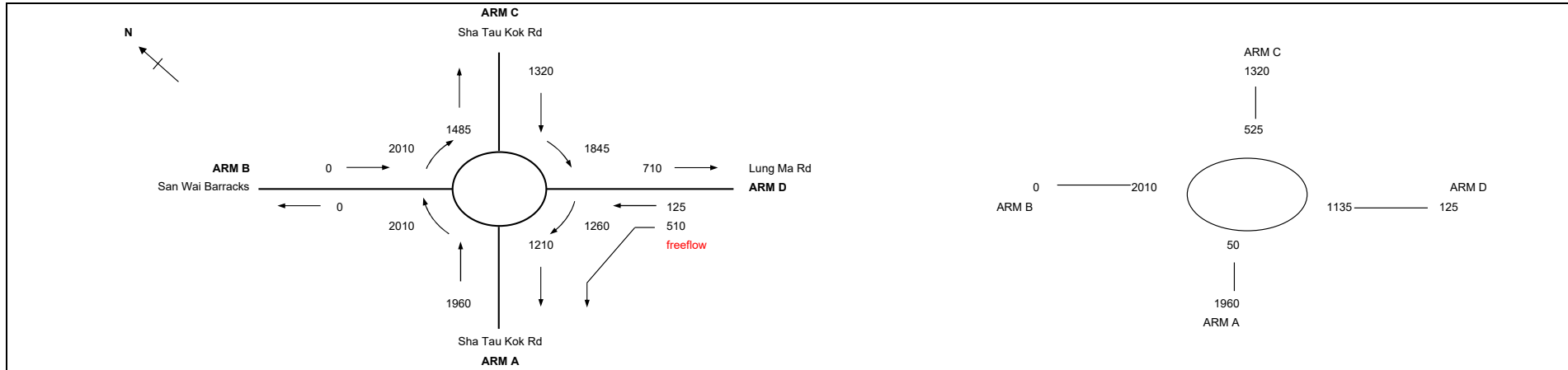

ARM	A	B	C	D
INPUT PARAMETERS:				
V = Approach half width (m)	7.30	3.30	7.30	3.50
E = Entry width (m)	10.00	5.00	10.00	5.00
L = Effective length of flare (m)	20	5	10	5
R = Entry radius (m)	30	60	30	70
D = Inscribed circle diameter (m)	50	50	50	50
A = Entry angle (degree)	15	15	25	15
Q = Entry flow (pcu/h)	1960	0	1320	125
Qc = Circulating flow across entry (pcu/h)	50	2010	525	1135
OUTPUT PARAMETERS:				
S = Sharpness of flare = 1.6(E-V)/L	0.22	0.54	0.43	0.48
K = 1-0.00347(A-30)-0.978(1/R-0.05)	1.07	1.08	1.03	1.09
X2 = V + ((E-V)/(1+2S))	9.19	4.11	8.75	4.27
M = EXP((D-60)/10)	0.37	0.37	0.37	0.37
F = 303*X2	2783	1247	2651	1292
Td = 1+(0.5/(1+M))	1.37	1.37	1.37	1.37
Fc = 0.21*Td(1+0.2*X2)	0.81	0.52	0.79	0.53
Qe = K(F-Fc*Qc)	2930	213	2312	749
DFC = Design flow/Capacity = Q/Qe	0.67	0.00	0.58	0.17
Total In Sum = 3280 PCU				
DFC of Critical Approach = 0.67				

J8 - Sha Tau Kok Road / Sui Wan Road

J8_2023_EXT_AM

PROJECT NO: 287082

Junction No. J8

DATE : 16/12/2024

FILENAME :

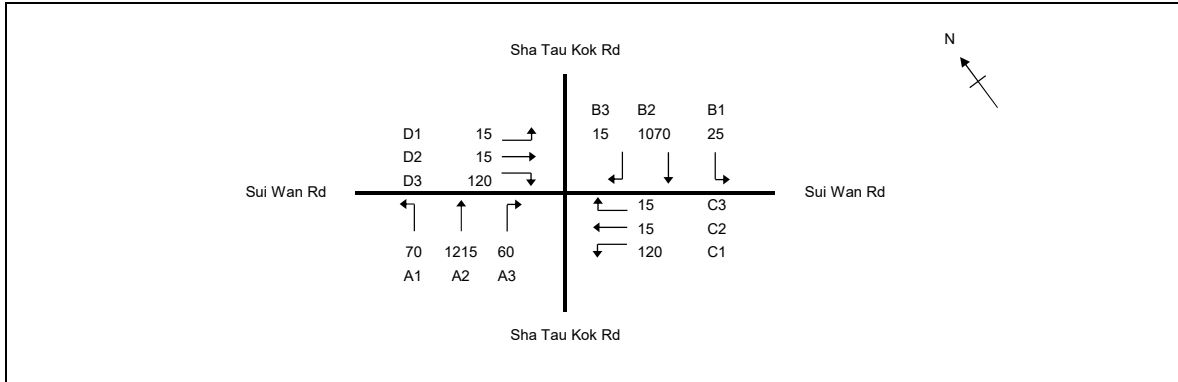

No. of stages per cycle	N = 4
No. of stage using for calculation	N = 3
Cycle time	C = 135 sec
Sum(y)	Y = 0.477
Loss time	L = 34 sec
Total Flow	= 2755 pcu
Co = (1.5*L+5)/(1-Y)	= 107.0 sec
Cm = L/(1-Y)	= 65.0 sec
Yult	= 0.645
R.C.ult = (Yult-Y)*100%	= 35.3 %
Cp = 0.9*L/(0.9-Y)	= 72.3 sec
Ymax = 1-L/C	= 0.748
R.C.(C) = (0.9*Ymax-Y)*100%	= 41 %

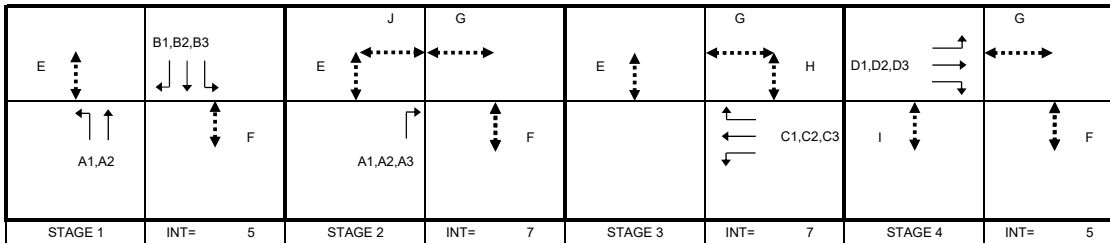

Pedestrian Phase	Width (m)	Green Time Required (s)			Green Time Provided (s)			Check
		SG	Delay	FG	SG	Delay	FG	
E	5	6	2	6	103	2	6	OK
F	5	6	2	6	101	2	6	OK
G	10.5	6	5	12	47	5	12	OK
H	5	6	2	6	16	2	6	OK
I	5	6	2	6	14	2	6	OK
J	8	6	5	9	6	5	9	OK

Move-ment	Stage	Lane Width m.	Phase	No. of lane	Radius m.	O	N	Straight-Ahead Sat. Flow	Flow			Total Flow pcu/h	Proportion of Turning Vehicles	Sat. Flow pcu/h	Uphill Gradient %	Short lane Effect pcu/h	Revised Sat. Flow pcu/h	y	Greater y	L sec	g (required) sec	g (input) sec	Degree of Saturation X	Queuing Length m.
									Left pcu/h	Straight pcu/h	Right pcu/h													
B1,B2	1	3.50	B	1	10		N	1965	25	502	527	0.05	1951			1951	0.270	0.308	14	57	65	0.559	61	
B2	1	3.50	B	1		O		2105		568	568	0.00	2105			2105	0.270			57	65	0.559	66	
B3	1	3.50	B	1				2105		15	15	0.00	1875			1875	0.008			2	65	0.017	2	
A1,A2	1	3.50	A	1	10			2105	70	567	637	0.11	2071			2071	0.308			65	65	0.637	74	
A2	1	3.50	A	1				2105		648	648	0.00	2105			2105	0.308			65	65	0.637	75	
A3	2	3.50	A	1	10			2105		60	60	1.00	1830			1830	0.033			7	14	0.316	12	
C1,C2,C3	3	4.00	C	1	10		N	2015	120	15	150	0.90	1775			1775	0.084	0.084		18	18	0.637	29	
D1,D2,D3	4	4.00	D	1	10		N	2015	15	15	150	0.90	1775			1775	0.084	0.084		18	18	0.637	29	
PED	2		J																20					

NOTE : 'O' - OPPOSING TRAFFIC

N - NEAR SIDE LANE

SG - STEADY GREEN

FG - FLASHING GREEN

PEDESTRIAN WALKING SPEED FOR SG(FG) = 1.2(0.9)m/s

QUEUING LENGTH = AVERAGE QUEUE * 6m

J8 - Sha Tau Kok Road / Sui Wan Road

J8_2023_EXT_PM

PROJECT NO: 287082

Junction No. J8

DATE : 16/12/2024

FILENAME :

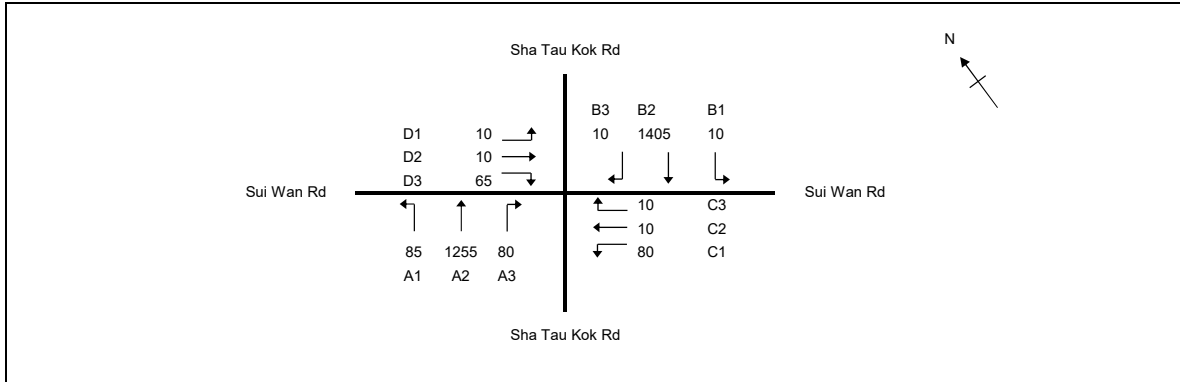

No. of stages per cycle	N = 4
No. of stage using for calculation	N = 3
Cycle time	C = 135 sec
Sum(y)	Y = 0.452
Loss time	L = 34 sec
Total Flow	= 3030 pcu
Co = (1.5*L+5)/(1-Y)	= 102.2 sec
Cm = L/(1-Y)	= 62.1 sec
Yult	= 0.645
R.C.ult = (Yult-Y)*100%	= 42.6 %
Cp = 0.9*L/(0.9-Y)	= 68.4 sec
Ymax = 1-L/C	= 0.748
R.C.(C) = (0.9*Ymax-Y)*100%	= 49 %

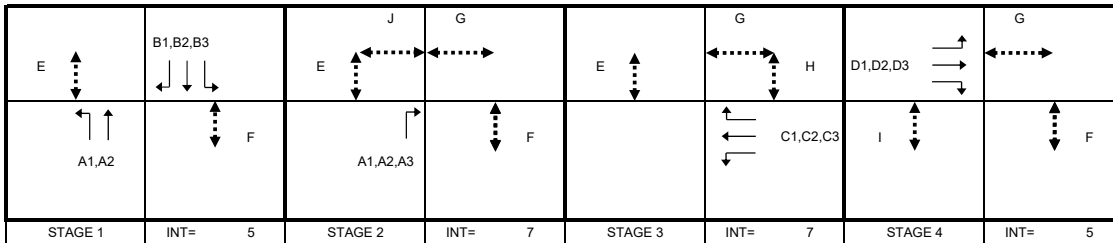

Pedestrian Phase	Width (m)	Green Time Required (s)			Green Time Provided (s)			Check
		SG	Delay	FG	SG	Delay	FG	
E	5	6	2	6	110	2	6	OK
F	5	6	2	6	106	2	6	OK
G	10.5	6	5	12	34	5	12	OK
H	5	6	2	6	11	2	6	OK
I	5	6	2	6	7	2	6	OK
J	8	6	5	9	6	5	9	OK

Move-ment	Stage	Lane Width m.	Phase	No. of lane	Radius m.	O	N	Straight-Ahead Sat. Flow	Flow			Total Flow pcu/h	Proportion of Turning Vehicles	Sat. Flow pcu/h	Uphill Gradient %	Short lane Effect pcu/h	Revised Sat. Flow pcu/h	y	Greater y	L sec	g (required) sec	g (input) sec	Degree of Saturation X	Queuing Length m.
									Left pcu/h	Straight pcu/h	Right pcu/h													
B1,B2	1	3.50	B	1	10		N	1965	10	672		682	0.01	1961		1961	0.348	0.348	14	78	78	0.604	65	
B2	1	3.50	B	1		O		2105		733		733	0.00	2105		2105	0.348			78	78	0.605	70	
B3	1	3.50	B	1				2105		10		10	0.00	1875		1875	0.005			1	78	0.009	1	
A1,A2	1	3.50	A	1	10			2105	85	579		664	0.13	2065		2065	0.321			72	78	0.558	63	
A2	1	3.50	A	1				2105		676		676	0.00	2105		2105	0.321			72	78	0.558	64	
A3	2	3.50	A	1	10			2105			80	80	1.00	1830		1830	0.044			10	14	0.421	16	
C1,C2,C3	3	4.00	C	1	10		N	2015	80	10	10	100	0.90	1775		1775	0.056	0.056		13	13	0.605	20	
D1,D2,D3	4	4.00	D	1	10		N	2015	10	10	65	85	0.88	1779		1779	0.048	0.048		11	11	0.605	18	
PED	2		J																20					

NOTE : 'O' - OPPOSING TRAFFIC

N - NEAR SIDE LANE

SG - STEADY GREEN

FG - FLASHING GREEN

PEDESTRIAN WALKING SPEED FOR SG(FG) = 1.2(0.9)m/s

QUEUING LENGTH = AVERAGE QUEUE * 6m

J8 - Sha Tau Kok Road / Sui Wan Road

J8_2031_REF_AM

PROJECT NO: 287082

Junction No. J8

DATE : 16/12/2024

FILENAME :

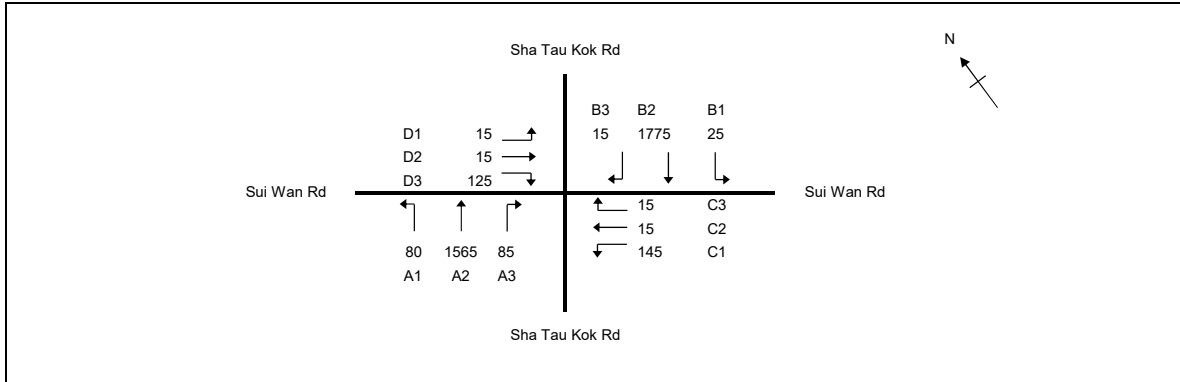

No. of stages per cycle	N = 4
No. of stage using for calculation	N = 3
Cycle time	C = 135 sec
Sum(y)	Y = 0.629
Loss time	L = 34 sec
Total Flow	= 3875 pcu
Co = (1.5*L+5)/(1-Y)	= 151.1 sec
Cm = L/(1-Y)	= 91.7 sec
Yult	= 0.645
R.C.ult = (Yult-Y)*100%	= 2.5 %
Cp = 0.9*L/(0.9-Y)	= 113.1 sec
Ymax = 1-L/C	= 0.748
R.C.(C) = (0.9*Ymax-Y)*100%	= 6 %

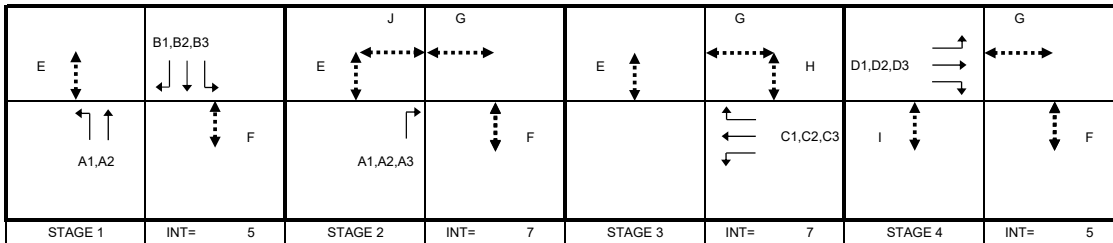

Pedestrian Phase	Width (m)	Green Time Required (s)			Green Time Provided (s)			Check
		SG	Delay	FG	SG	Delay	FG	
E	5	6	2	6	107	2	6	OK
F	5	6	2	6	103	2	6	OK
G	10.5	6	5	12	41	5	12	OK
H	5	6	2	6	14	2	6	OK
I	5	6	2	6	10	2	6	OK
J	8	6	5	9	6	5	9	OK

Move-ment	Stage	Lane Width m.	Phase	No. of lane	Radius m.	O	N	Straight-Ahead Sat. Flow	Flow			Total Flow pcu/h	Proportion of Turning Vehicles	Sat. Flow pcu/h	Uphill Gradient %	Short lane Effect pcu/h	Revised Sat. Flow pcu/h	y	Greater y	L sec	g (required) sec	g (input) sec	Degree of Saturation X	Queuing Length m.
									Left pcu/h	Straight pcu/h	Right pcu/h													
B1,B2	1	3.50	B	1	10		N	1965	25	842		867	0.03	1957		1957	0.443	0.443	14	71	71	0.841	92	
B2	1	3.50	B	1		O		2105		933		933	0.00	2105		2105	0.443			71	71	0.841	99	
B3	1	3.50	B	1				2105		15		15	0.00	1875		1875	0.008			1	71	0.015	2	
A1,A2	1	3.50	A	1	10			2105	80	737		817	0.10	2075		2075	0.394			63	71	0.747	87	
A2	1	3.50	A	1				2105		828		828	0.00	2105		2105	0.393			63	71	0.747	88	
A3	2	3.50	A	1	10			2105		85		85	1.00	1830		1830	0.046			7	14	0.448	17	
C1,C2,C3	3	4.00	C	1	10		N	2015	145	15	15	175	0.91	1772		1772	0.099	0.099		16	16	0.841	35	
D1,D2,D3	4	4.00	D	1	10		N	2015	15	15	125	155	0.90	1775		1775	0.087	0.087		14	14	0.841	31	
PED	2		J																20					

NOTE : 'O' - OPPOSING TRAFFIC

N - NEAR SIDE LANE

SG - STEADY GREEN

FG - FLASHING GREEN

PEDESTRIAN WALKING SPEED FOR SG(FG) = 1.2(0.9)m/s

QUEUING LENGTH = AVERAGE QUEUE * 6m

J8 - Sha Tau Kok Road / Sui Wan Road

J8_2031_REF_PM

PROJECT NO: 287082

Junction No. J8

DATE : 16/12/2024

FILENAME :

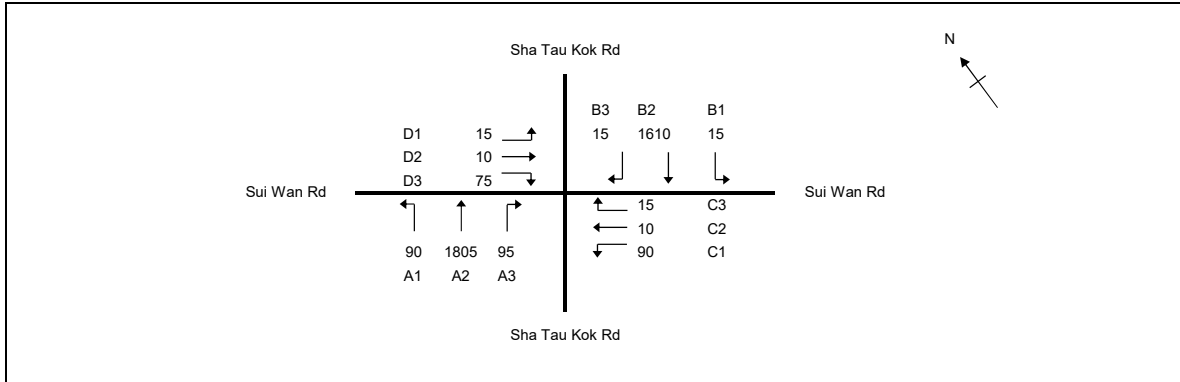

No. of stages per cycle	N = 4
No. of stage using for calculation	N = 2
Cycle time	C = 135 sec
Sum(y)	Y = 0.518
Loss time	L = 44 sec
Total Flow	= 3845 pcu
Co = (1.5*L+5)/(1-Y)	= 147.4 sec
Cm = L/(1-Y)	= 91.3 sec
Yult	= 0.570
R.C.ult = (Yult-Y)*100%	= 10.0 %
Cp = 0.9*L/(0.9-Y)	= 103.8 sec
Ymax = 1-L/C	= 0.674
R.C.(C) = (0.9*Ymax-Y)*100%	= 17 %

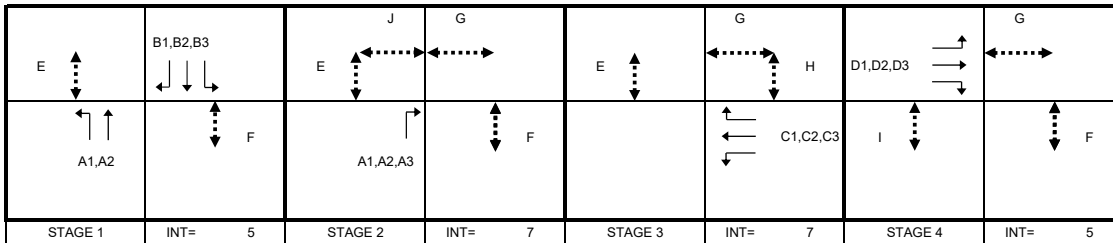

Pedestrian Phase	Width (m)	Green Time Required (s)			Green Time Provided (s)			Check
		SG	Delay	FG	SG	Delay	FG	
E	5	6	2	6	111	2	6	OK
F	5	6	2	6	108	2	6	OK
G	10.5	6	5	12	32	5	12	OK
H	5	6	2	6	9	2	6	OK
I	5	6	2	6	6	2	6	OK
J	8	6	5	9	6	5	9	OK

Move-ment	Stage	Lane Width m.	Phase	No. of lane	Radius m.	O	N	Straight-Ahead Sat. Flow	Flow			Total Flow pcu/h	Proportion of Turning Vehicles	Sat. Flow pcu/h	Uphill Gradient %	Short lane Effect pcu/h	Revised Sat. Flow pcu/h	y	Greater y	L sec	g (required) sec	g (input) sec	Degree of Saturation X	Queuing Length m.
									Left pcu/h	Straight pcu/h	Right pcu/h													
B1,B2	1	3.50	B	1	10		N	1965	15	768		783	0.02	1959		1959	0.400		10	70	80	0.678	72	
B2	1	3.50	B	1				2105		842		842	0.00	2105		2105	0.400			70	80	0.678	78	
B3	1	3.50	B	1		O		2105		15		15	0.00	1875		1875	0.008			1	80	0.014	1	
A1,A2	1	3.50	A	1	10			2105	90	851		941	0.10	2075		2075	0.453	0.453		80	80	0.769	87	
A2	1	3.50	A	1				2105		954		954	0.00	2105		2105	0.453			80	80	0.769	88	
A3	2	3.50	A	1	10			2105		95		95	1.00	1830		1830	0.052			9	14	0.500	19	
C1,C2,C3	3	4.00	C	1	10		N	2015	90	10	15	115	0.91	1772		1772	0.065	0.065		11	11	0.769	24	
D1,D2,D3	4	4.00	D	1	10		N	2015	15	10	75	100	0.90	1775		1775	0.056			10	10	0.760	21	
PED	2		J																20					
PED	4		I																14					

NOTE : 'O' - OPPOSING TRAFFIC

N - NEAR SIDE LANE

SG - STEADY GREEN

FG - FLASHING GREEN

PEDESTRIAN WALKING SPEED FOR SG(FG) = 1.2(0.9)m/s

QUEUING LENGTH = AVERAGE QUEUE * 6m

J8 - Sha Tau Kok Road / Sui Wan Road

J8_2031_DES_AM

PROJECT NO: 287082

Junction No. J8

DATE : 16/12/2024

FILENAME :

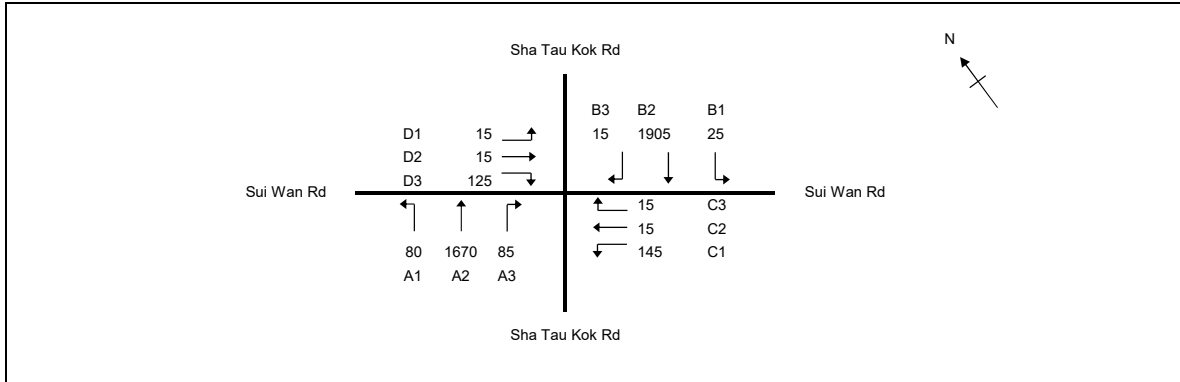

No. of stages per cycle	N = 4
No. of stage using for calculation	N = 3
Cycle time	C = 135 sec
Sum(y)	Y = 0.661
Loss time	L = 34 sec
Total Flow	= 4110 pcu
Co	= (1.5*L+5)/(1-Y) = 165.3 sec
Cm	= L/(1-Y) = 100.4 sec
Yult	= 0.645
R.C.ult	= (Yult-Y)*100% = -2.5 %
Cp	= 0.9*L/(0.9-Y) = 128.2 sec
Ymax	= 1-L/C = 0.748
R.C.(C)	= (0.9*Ymax-Y)*100% = 1 %

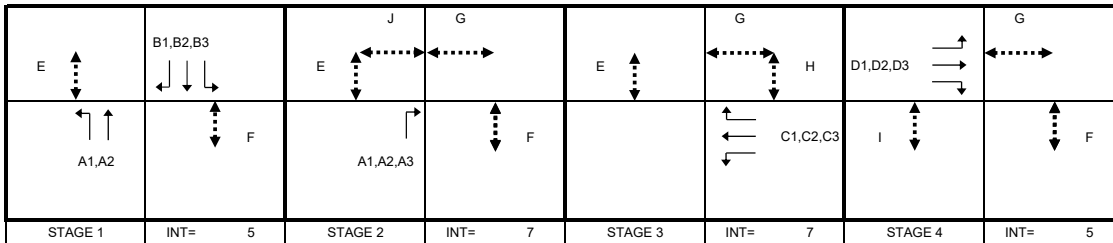

Pedestrian Phase	Width (m)	Green Time Required (s)			Green Time Provided (s)			Check
		SG	Delay	FG	SG	Delay	FG	
E	5	6	2	6	108	2	6	OK
F	5	6	2	6	104	2	6	OK
G	10.5	6	5	12	39	5	12	OK
H	5	6	2	6	13	2	6	OK
I	5	6	2	6	9	2	6	OK
J	8	6	5	9	6	5	9	OK

Move-ment	Stage	Lane Width m.	Phase	No. of lane	Radius m.	O	N	Straight-Ahead Sat. Flow	Flow			Total Flow pcu/h	Proportion of Turning Vehicles	Sat. Flow pcu/h	Uphill Gradient %	Short lane Effect pcu/h	Revised Sat. Flow pcu/h	y	Greater y	L sec	g (required) sec	g (input) sec	Degree of Saturation X	Queuing Length m.
									Left pcu/h	Straight pcu/h	Right pcu/h													
B1,B2	1	3.50	B	1	10		N	1965	25	905		930	0.03	1957		1957	0.475	0.475	14	73	73	0.884	97	
B2	1	3.50	B	1				2105		1000		1000	0.00	2105		2105	0.475			73	73	0.884	104	
B3	1	3.50	B	1		O		2105		15		15	0.00	1875		1875	0.008			1	73	0.015	2	
A1,A2	1	3.50	A	1	10			2105	80	789		869	0.09	2076		2076	0.419			64	73	0.779	90	
A2	1	3.50	A	1				2105		881		881	0.00	2105		2105	0.419			64	73	0.779	92	
A3	2	3.50	A	1	10			2105			85	85	1.00	1830		1830	0.046			7	14	0.448	17	
C1,C2,C3	3	4.00	C	1	10		N	2015	145	15	15	175	0.91	1772		1772	0.099	0.099		15	15	0.884	36	
D1,D2,D3	4	4.00	D	1	10		N	2015	15	15	125	155	0.90	1775		1775	0.087	0.087		13	13	0.884	34	
PED	2		J																20					

NOTE : 'O' - OPPOSING TRAFFIC

N - NEAR SIDE LANE

SG - STEADY GREEN

FG - FLASHING GREEN

PEDESTRIAN WALKING SPEED FOR SG(FG) = 1.2(0.9)m/s

QUEUING LENGTH = AVERAGE QUEUE * 6m

J8 - Sha Tau Kok Road / Sui Wan Road

J8_2031_DES_PM

PROJECT NO: 287082

Junction No. J8

DATE : 16/12/2024

FILENAME :

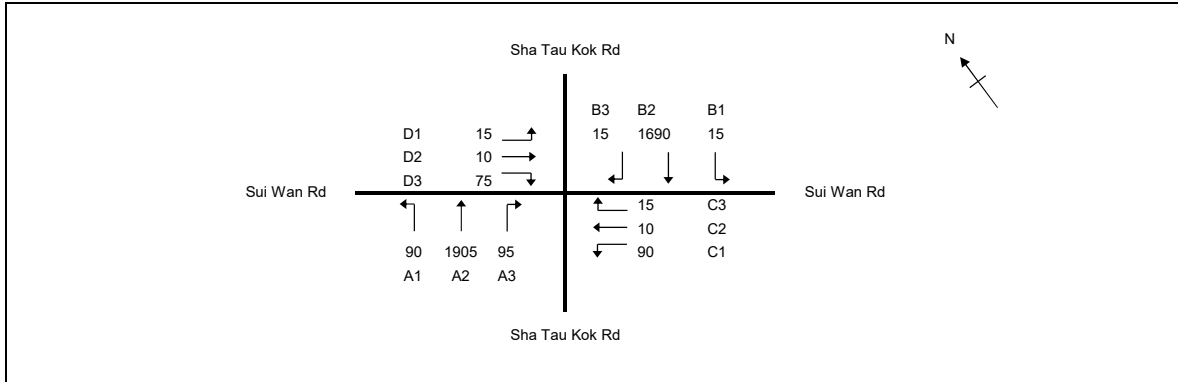

No. of stages per cycle	N = 4
No. of stage using for calculation	N = 2
Cycle time	C = 135 sec
Sum(y)	Y = 0.542
Loss time	L = 44 sec
Total Flow	= 4025 pcu
Co	= (1.5*L+5)/(1-Y) = 155.1 sec
Cm	= L/(1-Y) = 96.1 sec
Yult	= 0.570
R.C.ult	= (Yult-Y)*100% = 5.1 %
Cp	= 0.9*L/(0.9-Y) = 110.6 sec
Ymax	= 1-L/C = 0.674
R.C.(C)	= (0.9*Ymax-Y)*100% = 11 %

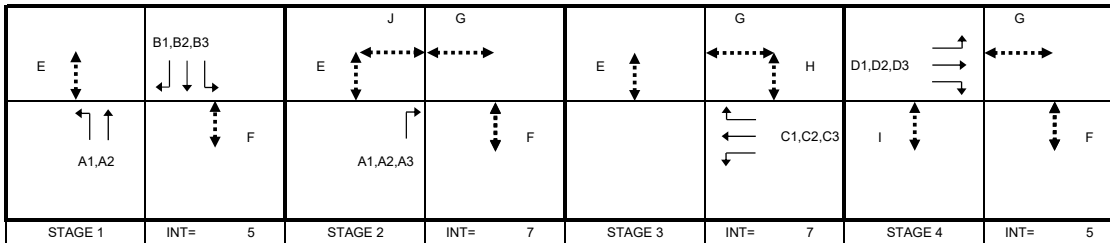

Pedestrian Phase	Width (m)	Green Time Required (s)			Green Time Provided (s)			Check
		SG	Delay	FG	SG	Delay	FG	
E	5	6	2	6	111	2	6	OK
F	5	6	2	6	108	2	6	OK
G	10.5	6	5	12	32	5	12	OK
H	5	6	2	6	9	2	6	OK
I	5	6	2	6	6	2	6	OK
J	8	6	5	9	6	5	9	OK

Move-ment	Stage	Lane Width m.	Phase	No. of lane	Radius m.	O	N	Straight-Ahead Sat. Flow	Flow			Total Flow pcu/h	Proportion of Turning Vehicles	Sat. Flow pcu/h	Uphill Gradient %	Short lane Effect pcu/h	Revised Sat. Flow pcu/h	y	Greater y	L sec	g (required) sec	g (input) sec	Degree of Saturation X	Queuing Length m.
									Left pcu/h	Straight pcu/h	Right pcu/h													
B1,B2	1	3.50	B	1	10		N	1965	15	807		822	0.02	1960		1960	0.419		10	70	80	0.707	75	
B2	1	3.50	B	1				2105		883		883	0.00	2105		2105	0.419			70	80	0.707	81	
B3	1	3.50	B	1		O		2105		15		15	0.00	1875		1875	0.008			1	80	0.013	1	
A1,A2	1	3.50	A	1	10			2105	90	901		991	0.09	2077		2077	0.477	0.477		80	80	0.804	91	
A2	1	3.50	A	1				2105		1004		1004	0.00	2105		2105	0.477			80	80	0.804	92	
A3	2	3.50	A	1	10			2105		95		95	1.00	1830		1830	0.052			9	14	0.500	19	
C1,C2,C3	3	4.00	C	1	10		N	2015	90	10	15	115	0.91	1772		1772	0.065	0.065		11	11	0.804	24	
D1,D2,D3	4	4.00	D	1	10		N	2015	15	10	75	100	0.90	1775		1775	0.056			9	9	0.804	21	
PED	2		J																20					
PED	4		I																14					

NOTE : 'O' - OPPOSING TRAFFIC N - NEAR SIDE LANE SG - STEADY GREEN FG - FLASHING GREEN PEDESTRIAN WALKING SPEED FOR SG(FG) = 1.2(0.9)m/s QUEUING LENGTH = AVERAGE QUEUE * 6m

PROJECT NO: 287082 DESIGNED BY:

J9 - Man Kam To Road / Kong Nga Po Road

J9_2023_EXT_AM

DATE : 16/12/2024 FILENAME :

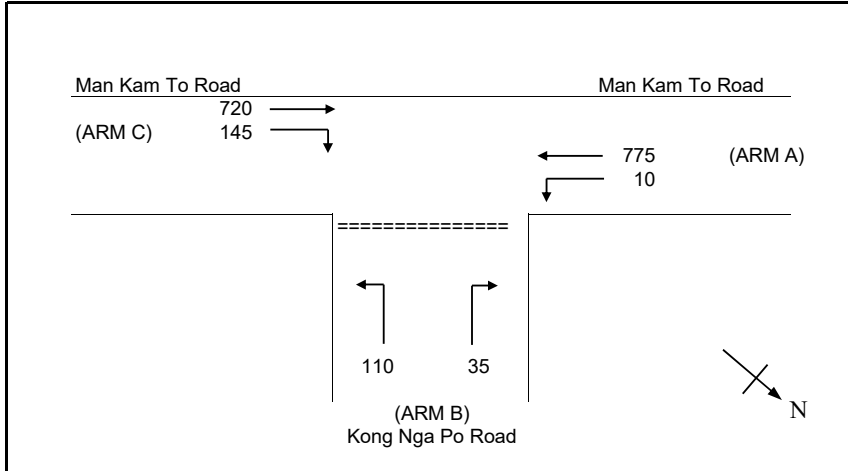

NOTES : (GEOMETRIC INPUT DATA)

- W = MAJOR ROAD WIDTH (6-20m) (minor road turn left only, 2W)
- W cr = CENTRAL RESERVE WIDTH (0m, 1.2-9m)
- W b-a = LANE WIDTH AVAILABLE TO VEHICLE WAITING IN STREAM b-a (0m, 2.2-5m)
- W b-c = LANE WIDTH AVAILABLE TO VEHICLE WAITING IN STREAM b-c (2.2-5m)
- W c-b = LANE WIDTH AVAILABLE TO VEHICLE WAITING IN STREAM c-b (0m, 2.2-5m)
- VI b-a = VISIBILITY TO THE LEFT FOR VEHICLES WAITING IN STREAM b-a (0-250m)
- Vr b-a = VISIBILITY TO THE RIGHT FOR VEHICLES WAITING IN STREAM b-a (0-250)
- Vr b-c = VISIBILITY TO THE RIGHT FOR VEHICLES WAITING IN STREAM b-c (0-250)
- Vr c-b = VISIBILITY TO THE RIGHT FOR VEHICLES WAITING IN STREAM c-b (0-250)
- D = STREAM-SPECIFIC B-A
- E = STREAM-SPECIFIC B-C
- F = STREAM-SPECIFIC C-B
- Y = (1-0.0345W)

GEOMETRIC DETAILS:

MAJOR ROAD (ARM A)
 W = 11.00 (metres)
 W cr = 2.00 (metres)
 q a-b = 10 (pcu/hr)
 q a-c = 775 (pcu/hr)

MAJOR ROAD (ARM C)
 W c-b = 4.00 (metres)
 Vr c-b = 50 (metres)
 q c-a = 720 (pcu/hr)
 q c-b = 145 (pcu/hr)

MINOR ROAD (ARM B)
 W b-a = 4.00 (metres)
 W b-c = 4.50 (metres)
 VI b-a = 100 (metres)
 Vr b-a = 50 (metres)
 Vr b-c = 50 (metres)
 q b-a = 35 (pcu/hr)
 q b-c = 110 (pcu/hr)

GEOMETRIC FACTORS :

D = 0.94
 E = 1.01
 F = 0.97
 Y = 0.62

THE CAPACITY OF MOVEMENT :

Q b-a = 310
 Q b-c = 576
 Q c-b = 549
 Q b-ac = 477

TOTAL FLOW = 1795 (PCU/HR)

COMPARISON OF DESIGN FLOW TO CAPACITY:

DFC b-a = 0.11
 DFC b-c = 0.19
 DFC c-b = 0.26
 DFC b-ac = 0.30

CRITICAL DFC = 0.30

PROJECT NO: 287082 DESIGNED BY:

J9 - Man Kam To Road / Kong Nga Po Road

J9_2023_EXT_PM

DATE : 16/12/2024 FILENAME :

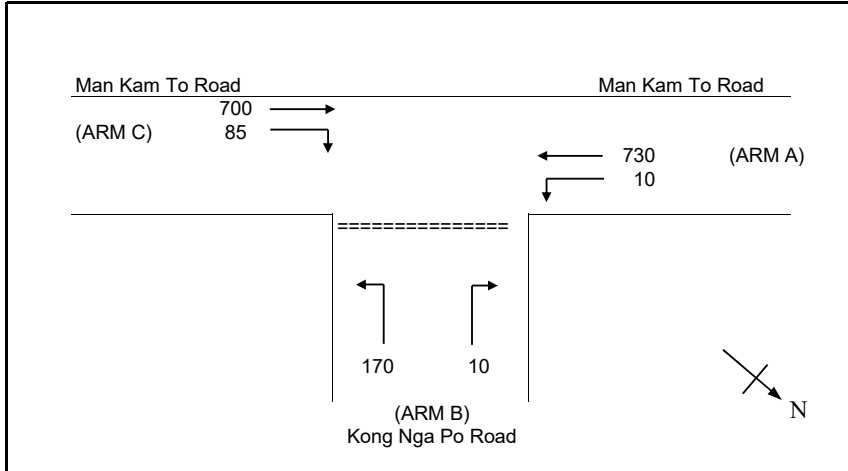

NOTES : (GEOMETRIC INPUT DATA)

- W = MAJOR ROAD WIDTH (6-20m) (minor road turn left only, 2W)
- W cr = CENTRAL RESERVE WIDTH (0m, 1.2-9m)
- W b-a = LANE WIDTH AVAILABLE TO VEHICLE WAITING IN STREAM b-a (0m, 2.2-5m)
- W b-c = LANE WIDTH AVAILABLE TO VEHICLE WAITING IN STREAM b-c (2.2-5m)
- W c-b = LANE WIDTH AVAILABLE TO VEHICLE WAITING IN STREAM c-b (0m, 2.2-5m)
- VI b-a = VISIBILITY TO THE LEFT FOR VEHICLES WAITING IN STREAM b-a (0-250m)
- Vr b-a = VISIBILITY TO THE RIGHT FOR VEHICLES WAITING IN STREAM b-a (0-250)
- Vr b-c = VISIBILITY TO THE RIGHT FOR VEHICLES WAITING IN STREAM b-c (0-250)
- Vr c-b = VISIBILITY TO THE RIGHT FOR VEHICLES WAITING IN STREAM c-b (0-250)
- D = STREAM-SPECIFIC B-A
- E = STREAM-SPECIFIC B-C
- F = STREAM-SPECIFIC C-B
- Y = (1-0.0345W)

GEOMETRIC DETAILS:

MAJOR ROAD (ARM A)

- W = 11.00 (metres)
- W cr = 2.00 (metres)
- q a-b = 10 (pcu/hr)
- q a-c = 730 (pcu/hr)

MAJOR ROAD (ARM C)

- W c-b = 4.00 (metres)
- Vr c-b = 50 (metres)
- q c-a = 700 (pcu/hr)
- q c-b = 85 (pcu/hr)

MINOR ROAD (ARM B)

- W b-a = 4.00 (metres)
- W b-c = 4.50 (metres)
- VI b-a = 100 (metres)
- Vr b-a = 50 (metres)
- Vr b-c = 50 (metres)
- q b-a = 10 (pcu/hr)
- q b-c = 170 (pcu/hr)

GEOMETRIC FACTORS :

- D = 0.94
- E = 1.01
- F = 0.97
- Y = 0.62

THE CAPACITY OF MOVEMENT :

- Q b-a = 340
- Q b-c = 586
- Q c-b = 559
- Q b-ac = 563

TOTAL FLOW = 1705 (PCU/HR)

COMPARISON OF DESIGN FLOW TO CAPACITY:

- DFC b-a = 0.03
- DFC b-c = 0.29
- DFC c-b = 0.15
- DFC b-ac = 0.32

CRITICAL DFC = 0.32

PROJECT NO: 287082 DESIGNED BY:

J9 - Man Kam To Road / Kong Nga Po Road

J9_2031_REF_AM

DATE : 16/12/2024 FILENAME :

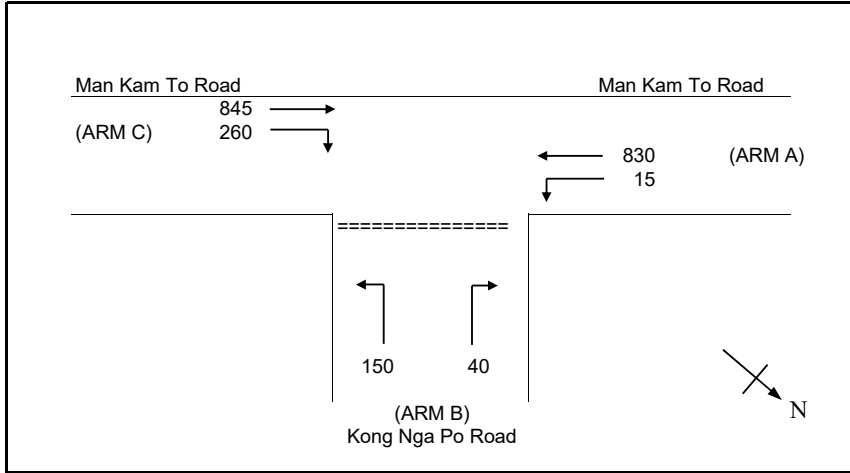

NOTES : (GEOMETRIC INPUT DATA)

- W = MAJOR ROAD WIDTH (6-20m) (minor road turn left only, 2W)
- W cr = CENTRAL RESERVE WIDTH (0m, 1.2-9m)
- W b-a = LANE WIDTH AVAILABLE TO VEHICLE WAITING IN STREAM b-a (0m, 2.2-5m)
- W b-c = LANE WIDTH AVAILABLE TO VEHICLE WAITING IN STREAM b-c (2.2-5m)
- W c-b = LANE WIDTH AVAILABLE TO VEHICLE WAITING IN STREAM c-b (0m, 2.2-5m)
- VI b-a = VISIBILITY TO THE LEFT FOR VEHICLES WAITING IN STREAM b-a (0-250m)
- Vr b-a = VISIBILITY TO THE RIGHT FOR VEHICLES WAITING IN STREAM b-a (0-250)
- Vr b-c = VISIBILITY TO THE RIGHT FOR VEHICLES WAITING IN STREAM b-c (0-250)
- Vr c-b = VISIBILITY TO THE RIGHT FOR VEHICLES WAITING IN STREAM c-b (0-250)
- D = STREAM-SPECIFIC B-A
- E = STREAM-SPECIFIC B-C
- F = STREAM-SPECIFIC C-B
- Y = (1-0.0345W)

GEOMETRIC DETAILS:	GEOMETRIC FACTORS :	THE CAPACITY OF MOVEMENT :	COMPARISON OF DESIGN FLOW TO CAPACITY:
MAJOR ROAD (ARM A) W = 11.00 (metres) W cr = 2.00 (metres) q a-b = 15 (pcu/hr) q a-c = 830 (pcu/hr)	D = 0.94 E = 1.01 F = 0.97 Y = 0.62	Q b-a = 246 Q b-c = 563 Q c-b = 536 Q b-ac = 443	DFC b-a = 0.17 DFC b-c = 0.27 DFC c-b = 0.49 DFC b-ac = 0.43
MAJOR ROAD (ARM C) W c-b = 4.00 (metres) Vr c-b = 50 (metres) q c-a = 845 (pcu/hr) q c-b = 260 (pcu/hr)		TOTAL FLOW = 2140 (PCU/HR)	
MINOR ROAD (ARM B) W b-a = 4.00 (metres) W b-c = 4.50 (metres) VI b-a = 100 (metres) Vr b-a = 50 (metres) Vr b-c = 50 (metres) q b-a = 40 (pcu/hr) q b-c = 150 (pcu/hr)			CRITICAL DFC = 0.49

PROJECT NO: 287082 DESIGNED BY:

J9 - Man Kam To Road / Kong Nga Po Road

J9_2031_REF_PM

DATE : 16/12/2024 FILENAME :

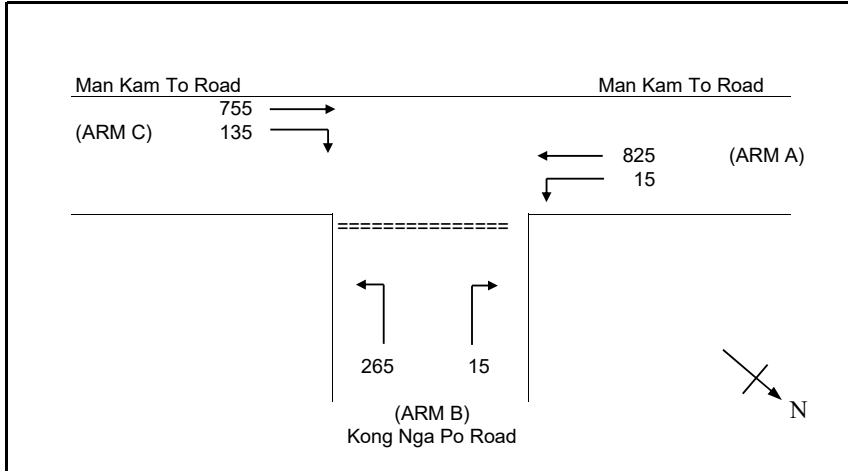

NOTES : (GEOMETRIC INPUT DATA)

- W = MAJOR ROAD WIDTH (6-20m) (minor road turn left only, 2W)
- W cr = CENTRAL RESERVE WIDTH (0m, 1.2-9m)
- W b-a = LANE WIDTH AVAILABLE TO VEHICLE WAITING IN STREAM b-a (0m, 2.2-5m)
- W b-c = LANE WIDTH AVAILABLE TO VEHICLE WAITING IN STREAM b-c (2.2-5m)
- W c-b = LANE WIDTH AVAILABLE TO VEHICLE WAITING IN STREAM c-b (0m, 2.2-5m)
- VI b-a = VISIBILITY TO THE LEFT FOR VEHICLES WAITING IN STREAM b-a (0-250m)
- Vr b-a = VISIBILITY TO THE RIGHT FOR VEHICLES WAITING IN STREAM b-a (0-250)
- Vr b-c = VISIBILITY TO THE RIGHT FOR VEHICLES WAITING IN STREAM b-c (0-250)
- Vr c-b = VISIBILITY TO THE RIGHT FOR VEHICLES WAITING IN STREAM c-b (0-250)
- D = STREAM-SPECIFIC B-A
- E = STREAM-SPECIFIC B-C
- F = STREAM-SPECIFIC C-B
- Y = (1-0.0345W)

GEOMETRIC DETAILS:

MAJOR ROAD (ARM A)
 W = 11.00 (metres)
 W cr = 2.00 (metres)
 q a-b = 15 (pcu/hr)
 q a-c = 825 (pcu/hr)

MAJOR ROAD (ARM C)
 W c-b = 4.00 (metres)
 Vr c-b = 50 (metres)
 q c-a = 755 (pcu/hr)
 q c-b = 135 (pcu/hr)

MINOR ROAD (ARM B)
 W b-a = 4.00 (metres)
 W b-c = 4.50 (metres)
 VI b-a = 100 (metres)
 Vr b-a = 50 (metres)
 Vr b-c = 50 (metres)
 q b-a = 15 (pcu/hr)
 q b-c = 265 (pcu/hr)

GEOMETRIC FACTORS :

D = 0.94
 E = 1.01
 F = 0.97
 Y = 0.62

THE CAPACITY OF MOVEMENT :

Q b-a = 297
 Q b-c = 564
 Q c-b = 537
 Q b-ac = 538

TOTAL FLOW = 2010 (PCU/HR)

COMPARISON OF DESIGN FLOW TO CAPACITY:

DFC b-a = 0.06
 DFC b-c = 0.47
 DFC c-b = 0.26
 DFC b-ac = 0.53

CRITICAL DFC = 0.53

PROJECT NO: 287082 DESIGNED BY:

J9 - Man Kam To Road / Kong Nga Po Road

J9_2031_DES_AM

DATE : 16/12/2024 FILENAME :

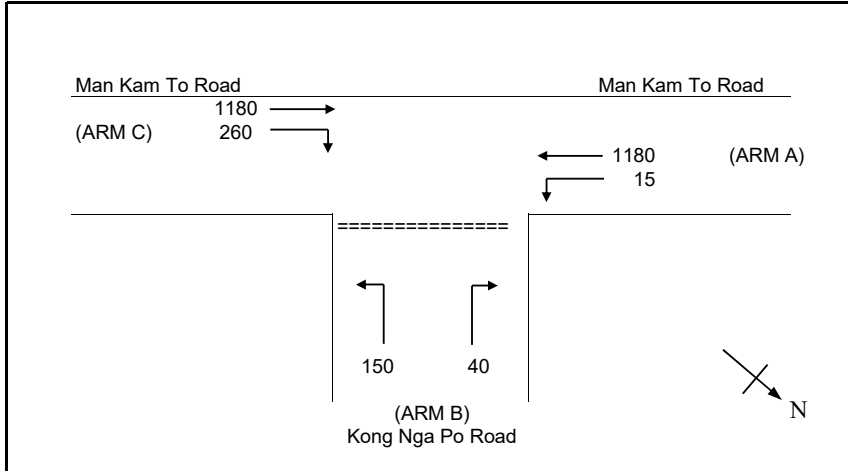

NOTES : (GEOMETRIC INPUT DATA)

- W = MAJOR ROAD WIDTH (6-20m) (minor road turn left only, 2W)
- W cr = CENTRAL RESERVE WIDTH (0m, 1.2-9m)
- W b-a = LANE WIDTH AVAILABLE TO VEHICLE WAITING IN STREAM b-a (0m, 2.2-5m)
- W b-c = LANE WIDTH AVAILABLE TO VEHICLE WAITING IN STREAM b-c (2.2-5m)
- W c-b = LANE WIDTH AVAILABLE TO VEHICLE WAITING IN STREAM c-b (0m, 2.2-5m)
- VI b-a = VISIBILITY TO THE LEFT FOR VEHICLES WAITING IN STREAM b-a (0-250m)
- Vr b-a = VISIBILITY TO THE RIGHT FOR VEHICLES WAITING IN STREAM b-a (0-250)
- Vr b-c = VISIBILITY TO THE RIGHT FOR VEHICLES WAITING IN STREAM b-c (0-250)
- Vr c-b = VISIBILITY TO THE RIGHT FOR VEHICLES WAITING IN STREAM c-b (0-250)
- D = STREAM-SPECIFIC B-A
- E = STREAM-SPECIFIC B-C
- F = STREAM-SPECIFIC C-B
- Y = (1-0.0345W)

GEOMETRIC DETAILS:

MAJOR ROAD (ARM A)
 W = 11.00 (metres)
 W cr = 2.00 (metres)
 q a-b = 15 (pcu/hr)
 q a-c = 1180 (pcu/hr)

MAJOR ROAD (ARM C)
 W c-b = 4.00 (metres)
 Vr c-b = 50 (metres)
 q c-a = 1180 (pcu/hr)
 q c-b = 260 (pcu/hr)

MINOR ROAD (ARM B)
 W b-a = 4.00 (metres)
 W b-c = 4.50 (metres)
 VI b-a = 100 (metres)
 Vr b-a = 50 (metres)
 Vr b-c = 50 (metres)
 q b-a = 40 (pcu/hr)
 q b-c = 150 (pcu/hr)

GEOMETRIC FACTORS :

D = 0.94
 E = 1.01
 F = 0.97
 Y = 0.62

THE CAPACITY OF MOVEMENT :

Q b-a = 127
 Q b-c = 483
 Q c-b = 460
 Q b-ac = 304

TOTAL FLOW = 2825 (PCU/HR)

COMPARISON OF DESIGN FLOW TO CAPACITY:

DFC b-a = 0.32
 DFC b-c = 0.32
 DFC c-b = 0.57
 DFC b-ac = 0.63

CRITICAL DFC = 0.63

PROJECT NO: 287082 DESIGNED BY:

J9 - Man Kam To Road / Kong Nga Po Road

J9_2031_DES_PM

DATE : 16/12/2024 FILENAME :

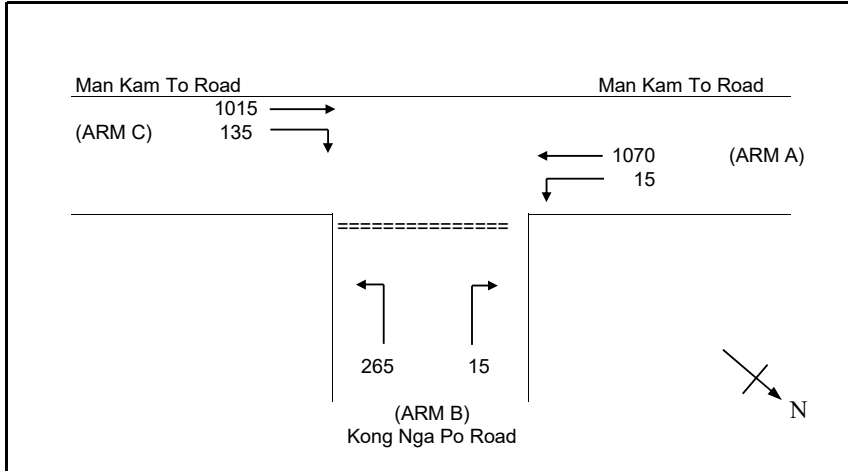

NOTES : (GEOMETRIC INPUT DATA)

- W = MAJOR ROAD WIDTH (6-20m) (minor road turn left only, 2W)
- W cr = CENTRAL RESERVE WIDTH (0m, 1.2-9m)
- W b-a = LANE WIDTH AVAILABLE TO VEHICLE WAITING IN STREAM b-a (0m, 2.2-5m)
- W b-c = LANE WIDTH AVAILABLE TO VEHICLE WAITING IN STREAM b-c (2.2-5m)
- W c-b = LANE WIDTH AVAILABLE TO VEHICLE WAITING IN STREAM c-b (0m, 2.2-5m)
- VI b-a = VISIBILITY TO THE LEFT FOR VEHICLES WAITING IN STREAM b-a (0-250m)
- Vr b-a = VISIBILITY TO THE RIGHT FOR VEHICLES WAITING IN STREAM b-a (0-250)
- Vr b-c = VISIBILITY TO THE RIGHT FOR VEHICLES WAITING IN STREAM b-c (0-250)
- Vr c-b = VISIBILITY TO THE RIGHT FOR VEHICLES WAITING IN STREAM c-b (0-250)
- D = STREAM-SPECIFIC B-A
- E = STREAM-SPECIFIC B-C
- F = STREAM-SPECIFIC C-B
- Y = (1-0.0345W)

GEOMETRIC DETAILS:

MAJOR ROAD (ARM A)
 W = 11.00 (metres)
 W cr = 2.00 (metres)
 q a-b = 15 (pcu/hr)
 q a-c = 1070 (pcu/hr)

MAJOR ROAD (ARM C)
 W c-b = 4.00 (metres)
 Vr c-b = 50 (metres)
 q c-a = 1015 (pcu/hr)
 q c-b = 135 (pcu/hr)

MINOR ROAD (ARM B)
 W b-a = 4.00 (metres)
 W b-c = 4.50 (metres)
 VI b-a = 100 (metres)
 Vr b-a = 50 (metres)
 Vr b-c = 50 (metres)
 q b-a = 15 (pcu/hr)
 q b-c = 265 (pcu/hr)

GEOMETRIC FACTORS :

D = 0.94
 E = 1.01
 F = 0.97
 Y = 0.62

THE CAPACITY OF MOVEMENT :

Q b-a = 210
 Q b-c = 508
 Q c-b = 484
 Q b-ac = 472

TOTAL FLOW = 2515 (PCU/HR)

COMPARISON OF DESIGN FLOW TO CAPACITY:

DFC b-a = 0.08
 DFC b-c = 0.53
 DFC c-b = 0.28
 DFC b-ac = 0.60

CRITICAL DFC = 0.60

J10 - Jockey Club Road / Po Wan Road

J10_2023_EXT_AM

PROJECT NO: 287082

Junction No. J10

DATE : 16/12/2024

FILENAME :

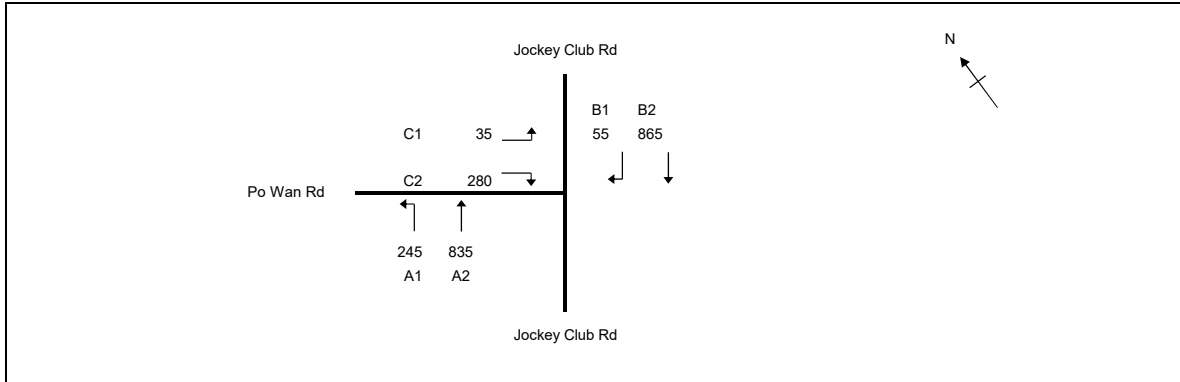

No. of stages per cycle	N = 4
No. of stage using for calculation	N = 2
Cycle time	C = 90 sec
Sum(y)	Y = 0.359
Loss time	L = 35 sec
Total Flow	= 2315 pcu
Co	= (1.5*L+5)/(1-Y) = 89.8 sec
Cm	= L/(1-Y) = 54.6 sec
Yult	= 0.638
R.C.ult	= (Yult-Y)*100% = 77.4 %
Cp	= 0.9*L/(0.9-Y) = 58.3 sec
Ymax	= 1-L/C = 0.611
R.C.(C)	= (0.9*Ymax-Y)*100% = 53 %

	B1,B2		B1,B2	C1,C2		E	
	↓ ↓		↓ ↓	→		→	
				←			
	↑ ↑					↓	
	A1,A2					D	
STAGE 1	INT= 5	STAGE 2	INT= 6	STAGE 3	INT= 6	STAGE 4	INT=

Pedestrian Phase	Width (m)	Green Time Required (s)			Green Time Provided (s)			Check
		SG	Delay	FG	SG	Delay	FG	
D	8	7	2	7	11	2	7	OK
E	8	7	6	7	7	6	7	OK

Move-ment	Stage	Lane Width m.	Phase	No. of lane	Radius m.	O	N	Straight-Ahead Sat. Flow	Flow			Total Flow pcu/h	Proportion of Turning Vehicles	Sat. Flow pcu/h	Uphill Gradient %	Short lane Effect pcu/h	Revised Sat. Flow pcu/h	y	Greater y	L sec	g (required) sec	g (input) sec	Degree of Saturation X	Queuing Length m.
									Left pcu/h	Straight pcu/h	Right pcu/h													
A1,A2	1	3.30	C	1	15		N	1945	245	264		509	0.48	1856		1856	0.274	0.274	9	42	42	0.588	41	
A2	1	3.30	C	1				2085		571		571	0.00	2085		2085	0.274			42	42	0.587	46	
B1,B2	1,2	3.30	B	1	20	O		2085	55	392		447	0.12	1838		1838	0.243			37	37	0.588	39	
B2	1,2	3.30	B	1			N	1945		473		473	0.00	1945		1945	0.243			37	37	0.588	42	
C1,C2	3	3.30	D	1	15		N	1945	35		115	150	1.00	1768		1768	0.085	0.085		13	13	0.586	19	
C2	3	3.30	D	1	20			2085			165	165	1.00	1940		1940	0.085			13	13	0.588	21	
	2 4		PED																6 20					

NOTE : 'O' - OPPOSING TRAFFIC N - NEAR SIDE LANE SG - STEADY GREEN FG - FLASHING GREEN PEDESTRIAN WALKING SPEED FOR SG(FG) = 1.2(0.9)m/s QUEUING LENGTH = AVERAGE QUEUE * 6m

J10 - Jockey Club Road / Po Wan Road

J10_2023_EXT_PM

PROJECT NO: 287082

Junction No. J10

DATE : 16/12/2024

FILENAME :

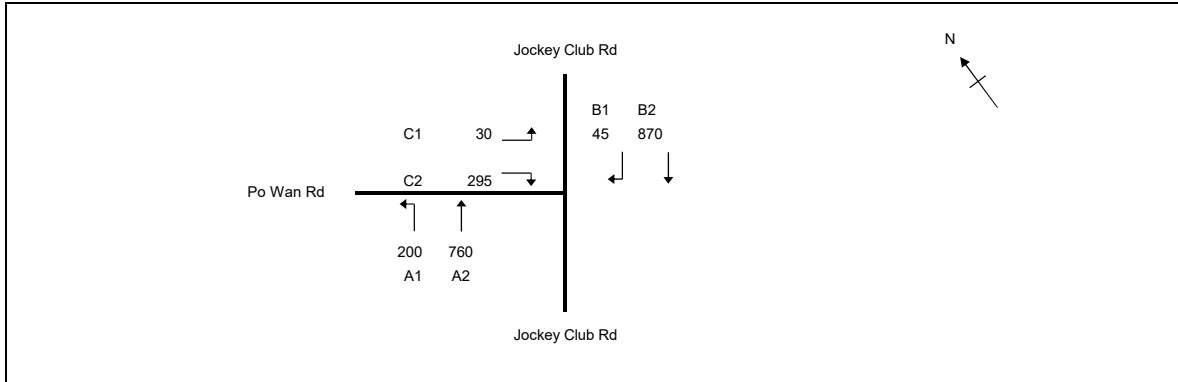

No. of stages per cycle	N =	4
No. of stage using for calculation	N =	2
Cycle time	C =	90 sec
Sum(y)	Y =	0.331
Loss time	L =	35 sec
Total Flow	=	2200 pcu
Co	= (1.5*L+5)/(1-Y)	= 85.9 sec
Cm	= L/(1-Y)	= 52.3 sec
Yult	=	0.638
R.C.ult	= (Yult-Y)*Y*100%	= 92.7 %
Cp	= 0.9*L/(0.9-Y)	= 55.3 sec
Ymax	= 1-L/C	= 0.611
R.C.(C)	= (0.9*Ymax-Y)*Y*100%	= 66 %

	B1,B2 ↓ ↓		B1,B2 ↓ ↓	C1,C2 → ←			E →
	A1,A2 ↑ ↑						D ↓
STAGE 1	INT= 5	STAGE 2	INT= 6	STAGE 3	INT= 6	STAGE 4	INT=

Pedestrian Phase	Width (m)	Green Time Required (s)			Green Time Provided (s)			Check
		SG	Delay	FG	SG	Delay	FG	
D	8	7	2	7	11	2	7	OK
E	8	7	6	7	7	6	7	OK

Move-ment	Stage	Lane Width m.	Phase	No. of lane	Radius m.	O	N	Straight-Ahead Sat. Flow	Flow			Total Flow pcu/h	Proportion of Turning Vehicles	Sat. Flow pcu/h	Uphill Gradient %	Short lane Effect pcu/h	Revised Sat. Flow pcu/h	y	Greater y	L sec	g (required) sec	g (input) sec	Degree of Saturation X	Queuing Length m.
									Left pcu/h	Straight pcu/h	Right pcu/h													
A1,A2	1	3.30	C	1	15		N	1945	200	253		453	0.44	1863		1863	0.243	0.243	9	40	40	0.541	37	
A2	1	3.30	C	1				2085		507		507	0.00	2085		2085	0.243			40	40	0.541	42	
B1,B2	1,2	3.30	B	1	20	O		2085	45	400		445	0.10	1841		1841	0.242			40	40	0.541	37	
B2	1,2	3.30	B	1			N	1945		470		470	0.00	1945		1945	0.242			40	40	0.541	39	
C1,C2	3	3.30	D	1	15		N	1945	30		125	155	1.00	1768		1768	0.088	0.088		15	15	0.541	19	
C2	3	3.30	D	1	20			2085			170	170	1.00	1940		1940	0.088			15	15	0.541	21	
	2 4		PED																6 20					

NOTE : 'O' - OPPOSING TRAFFIC N - NEAR SIDE LANE SG - STEADY GREEN FG - FLASHING GREEN PEDESTRIAN WALKING SPEED FOR SG(FG) = 1.2(0.9)m/s QUEUING LENGTH = AVERAGE QUEUE * 6m

J10 - Jockey Club Road / Po Wan Road

J10_2031_REF_AM

PROJECT NO: 287082

Junction No. J10

DATE : 16/12/2024

FILENAME :

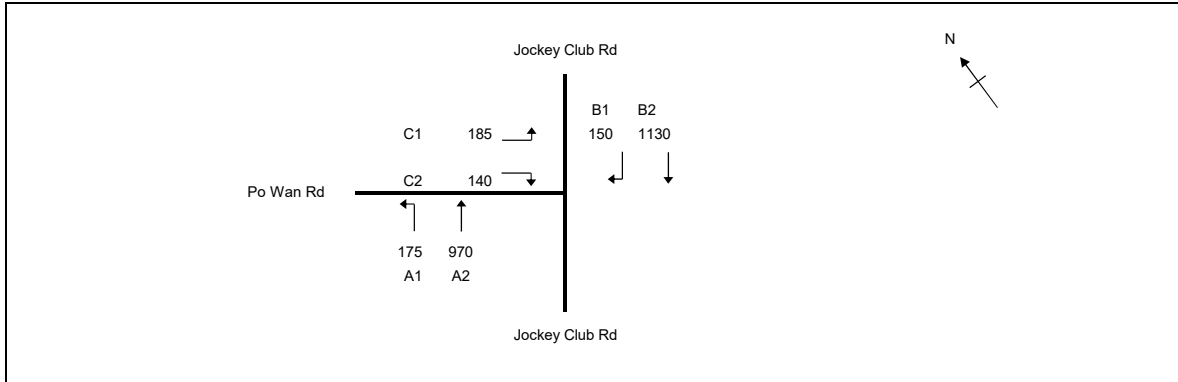

No. of stages per cycle	N =	4
No. of stage using for calculation	N =	2
Cycle time	C =	120 sec
Sum(y)	Y =	0.444
Loss time	L =	30 sec
Total Flow	=	2750 pcu
Co	= (1.5*L+5)/(1-Y)	= 90.0 sec
Cm	= L/(1-Y)	= 54.0 sec
Yult	=	0.675
R.C.ult	= (Yult-Y)*Y*100%	= 51.9 %
Cp	= 0.9*L/(0.9-Y)	= 59.3 sec
Ymax	= 1-L/C	= 0.750
R.C.(C)	= (0.9*Ymax-Y)*Y*100%	= 51 %

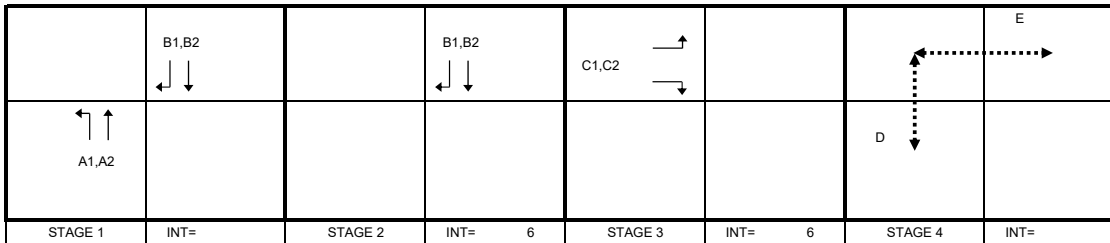

Pedestrian Phase	Width (m)	Green Time Required (s)			Green Time Provided (s)			Check
		SG	Delay	FG	SG	Delay	FG	
D	8	7	2	7	11	2	7	OK
E	8	7	6	7	7	6	7	OK

Move-ment	Stage	Lane Width m.	Phase	No. of lane	Radius m.	O	N	Straight-Ahead Sat. Flow	Flow			Total Flow pcu/h	Proportion of Turning Vehicles	Sat. Flow pcu/h	Uphill Gradient %	Short lane Effect pcu/h	Revised Sat. Flow pcu/h	y	Greater y	L sec	g (required) sec	g (input) sec	Degree of Saturation X	Queuing Length m.
									Left pcu/h	Straight pcu/h	Right pcu/h													
A1,A2	1	3.30	C	1	15		N	1945	175	369		544	0.32	1884		1884	0.289		10	58	63	0.552	52	
A2	1	3.30	C	1				2085		601		601	0.00	2085		2085	0.288			58	63	0.551	57	
B1,B2	1,2	3.30	B	1	20	O		2085	150	469		619	0.24	1822		1822	0.340	0.340		69	69	0.592	53	
B2	1,2	3.30	B	1			N	1945		661		661	0.00	1945		1945	0.340			69	69	0.593	56	
C1,C2	3	3.30	D	1	15		N	1945	185		0	185	1.00	1768		1768	0.105	0.105		21	21	0.593	30	
C2	3	3.30	D	1	20			2085			140	140	1.00	1940		1940	0.072			15	21	0.409	23	
	4		PED																20					

NOTE : 'O' - OPPOSING TRAFFIC

N - NEAR SIDE LANE

SG - STEADY GREEN

FG - FLASHING GREEN

PEDESTRIAN WALKING SPEED FOR SG(FG) = 1.2(0.9)m/s

QUEUING LENGTH = AVERAGE QUEUE * 6m

J10 - Jockey Club Road / Po Wan Road

J10_2031_REF_PM

PROJECT NO: 287082

Junction No. J10

DATE : 16/12/2024

FILENAME :

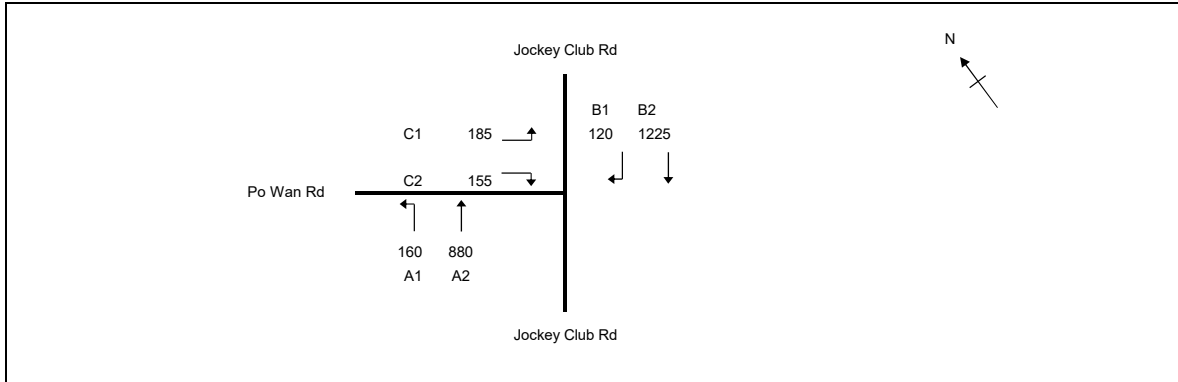

No. of stages per cycle	N = 4
No. of stage using for calculation	N = 2
Cycle time	C = 120 sec
Sum(y)	Y = 0.461
Loss time	L = 30 sec
Total Flow	= 2725 pcu
Co	= (1.5*L+5)/(1-Y) = 92.8 sec
Cm	= L/(1-Y) = 55.7 sec
Yult	= 0.675
R.C.ult	= (Yult-Y)*100% = 46.4 %
Cp	= 0.9*L/(0.9-Y) = 61.5 sec
Ymax	= 1-L/C = 0.750
R.C.(C)	= (0.9*Ymax-Y)*100% = 46 %

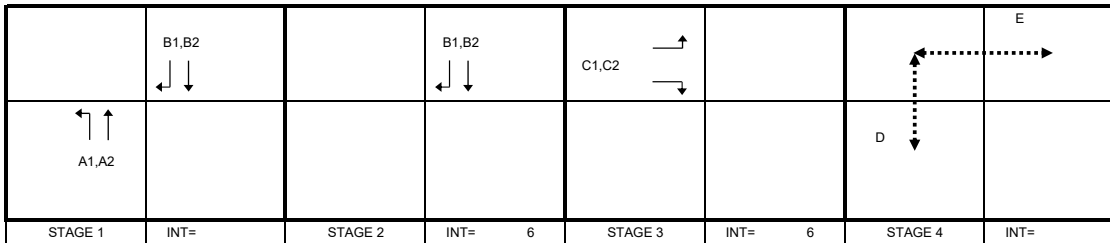

Pedestrian Phase	Width (m)	Green Time Required (s)			Green Time Provided (s)			Check
		SG	Delay	FG	SG	Delay	FG	
D	8	7	2	7	11	2	7	OK
E	8	7	6	7	7	6	7	OK

Move-ment	Stage	Lane Width m.	Phase	No. of lane	Radius m.	O	N	Straight-Ahead Sat. Flow	Flow			Total Flow pcu/h	Proportion of Turning Vehicles	Sat. Flow pcu/h	Uphill Gradient %	Short lane Effect pcu/h	Revised Sat. Flow pcu/h	y	Greater y	L sec	g (required) sec	g (input) sec	Degree of Saturation X	Queuing Length m.
									Left pcu/h	Straight pcu/h	Right pcu/h													
A1,A2	1	3.30	C	1	15		N	1945	160	334		494	0.32	1884		1884	0.262		10	51	64	0.495	46	
A2	1	3.30	C	1				2085		546		546	0.00	2085		2085	0.262			51	64	0.494	51	
B1,B2	1,2	3.30	B	1	20	O	N	2085	120	532		652	0.18	1830		1830	0.356	0.356		70	70	0.615	55	
B2	1,2	3.30	B	1			N	1945		693		693	0.00	1945		1945	0.356			70	70	0.615	58	
C1,C2	3	3.30	D	1	15		N	1945	185	0		185	1.00	1768		1768	0.105	0.105		20	20	0.615	31	
C2	3	3.30	D	1	20			2085		155		155	1.00	1940		1940	0.080			16	20	0.469	26	
	4		PED																20					

NOTE : 'O' - OPPOSING TRAFFIC

N - NEAR SIDE LANE

SG - STEADY GREEN

FG - FLASHING GREEN

PEDESTRIAN WALKING SPEED FOR SG(FG) = 1.2(0.9)m/s

QUEUING LENGTH = AVERAGE QUEUE * 6m

J10 - Jockey Club Road / Po Wan Road

J10_2031_DES_AM

PROJECT NO: 287082

Junction No. J10

DATE : 16/12/2024

FILENAME :

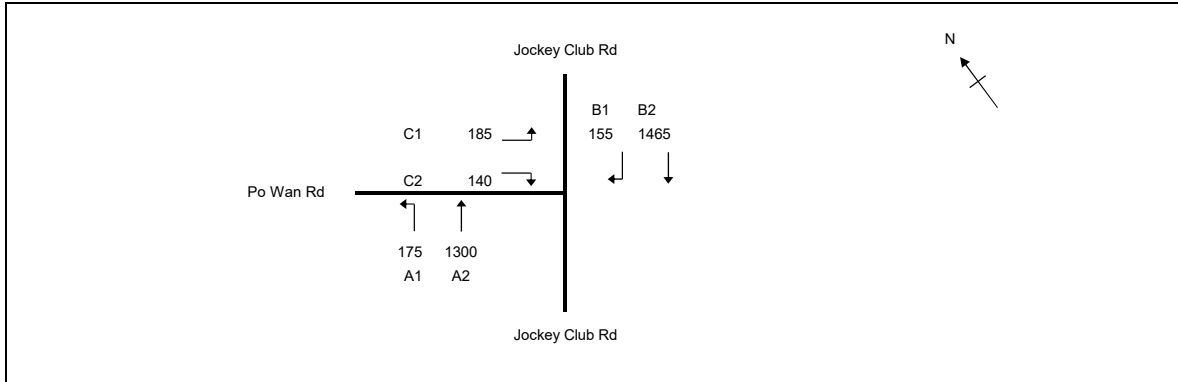

No. of stages per cycle	N = 4
No. of stage using for calculation	N = 2
Cycle time	C = 120 sec
Sum(y)	Y = 0.534
Loss time	L = 30 sec
Total Flow	= 3420 pcu
Co	= (1.5*L+5)/(1-Y) = 107.3 sec
Cm	= L/(1-Y) = 64.4 sec
Yult	= 0.675
R.C.ult	= (Yult-Y)*Y*100% = 26.4 %
Cp	= 0.9*L/(0.9-Y) = 73.8 sec
Ymax	= 1-L/C = 0.750
R.C.(C)	= (0.9*Ymax-Y)*Y*100% = 26 %

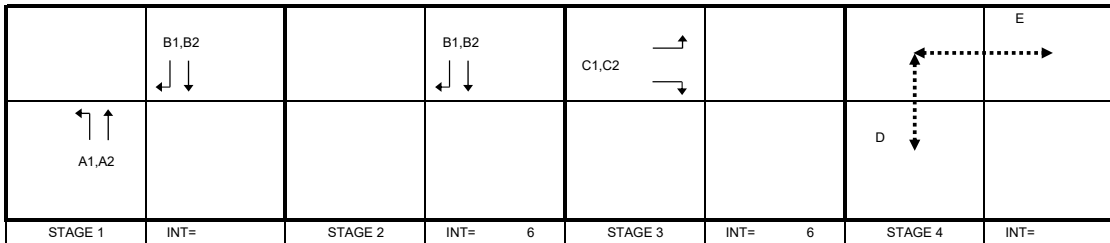

Pedestrian Phase	Width (m)	Green Time Required (s)			Green Time Provided (s)			Check
		SG	Delay	FG	SG	Delay	FG	
D	8	7	2	7	11	2	7	OK
E	8	7	6	7	7	6	7	OK

Move-ment	Stage	Lane Width m.	Phase	No. of lane	Radius m.	O	N	Straight-Ahead Sat. Flow	Flow			Total Flow pcu/h	Proportion of Turning Vehicles	Sat. Flow pcu/h	Uphill Gradient %	Short lane Effect pcu/h	Revised Sat. Flow pcu/h	y	Greater y	L sec	g (required) sec	g (input) sec	Degree of Saturation X	Queuing Length m.
									Left pcu/h	Straight pcu/h	Right pcu/h													
A1,A2	1	3.30	C	1	15		N	1945	175	528		703	0.25	1898		1898	0.370		10	62	66	0.670	63	
A2	1	3.30	C	1				2085		772		772	0.00	2085		2085	0.370			62	66	0.669	69	
B1,B2	1,2	3.30	B	1	20	O		2085	155	630		785	0.20	1828		1828	0.429	0.429		72	72	0.712	62	
B2	1,2	3.30	B	1			N	1945		835		835	0.00	1945		1945	0.429			72	72	0.712	66	
C1,C2	3	3.30	D	1	15		N	1945	185	0		185	1.00	1768		1768	0.105	0.105		18	18	0.712	32	
C2	3	3.30	D	1	20			2085		140		140	1.00	1940		1940	0.072			12	18	0.491	24	
	4		PED																20					

NOTE : 'O' - OPPOSING TRAFFIC

N - NEAR SIDE LANE

SG - STEADY GREEN

FG - FLASHING GREEN

PEDESTRIAN WALKING SPEED FOR SG(FG) = 1.2(0.9)m/s

QUEUING LENGTH = AVERAGE QUEUE * 6m

J10 - Jockey Club Road / Po Wan Road

J10_2031_DES_PM

PROJECT NO: 287082

Junction No. J10

DATE : 16/12/2024

FILENAME :

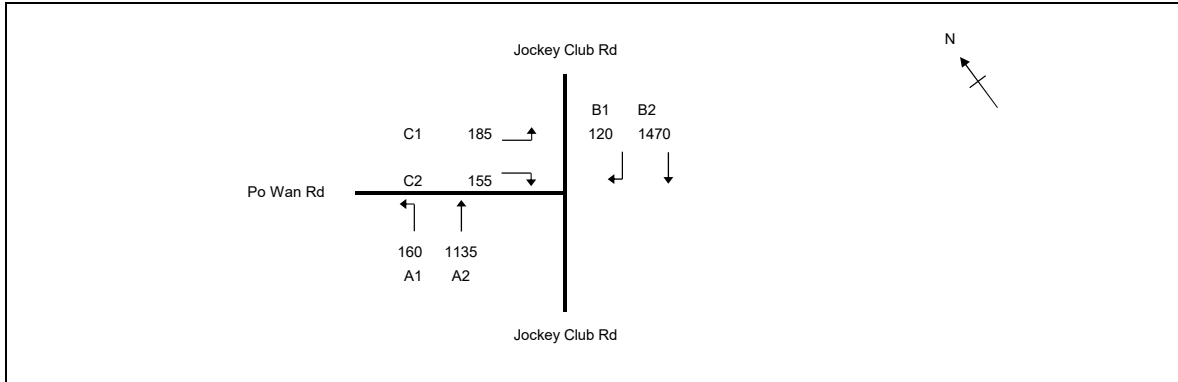

No. of stages per cycle	N = 4
No. of stage using for calculation	N = 2
Cycle time	C = 120 sec
Sum(y)	Y = 0.526
Loss time	L = 30 sec
Total Flow	= 3225 pcu
Co	= (1.5*L+5)/(1-Y) = 105.4 sec
Cm	= L/(1-Y) = 63.2 sec
Yult	= 0.675
R.C.ult	= (Yult-Y)*Y*100% = 28.4 %
Cp	= 0.9*L/(0.9-Y) = 72.1 sec
Ymax	= 1-L/C = 0.750
R.C.(C)	= (0.9*Ymax-Y)*Y*100% = 28 %

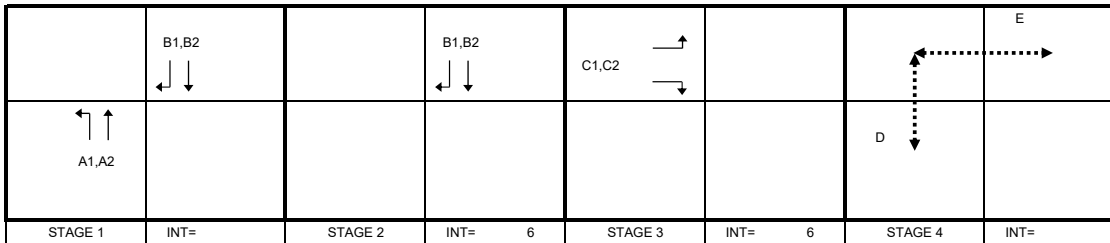

Pedestrian Phase	Width (m)	Green Time Required (s)			Green Time Provided (s)			Check
		SG	Delay	FG	SG	Delay	FG	
D	8	7	2	7	11	2	7	OK
E	8	7	6	7	7	6	7	OK

Move-ment	Stage	Lane Width m.	Phase	No. of lane	Radius m.	O	N	Straight-Ahead Sat. Flow	Flow			Total Flow pcu/h	Proportion of Turning Vehicles	Sat. Flow pcu/h	Uphill Gradient %	Short lane Effect pcu/h	Revised Sat. Flow pcu/h	y	Greater y	L sec	g (required) sec	g (input) sec	Degree of Saturation X	Queuing Length m.
									Left pcu/h	Straight pcu/h	Right pcu/h													
A1,A2	1	3.30	C	1	15		N	1945	160	457		617	0.26	1896		1896	0.325		10	56	66	0.591	55	
A2	1	3.30	C	1				2085		678		678	0.00	2085		2085	0.325			56	66	0.590	61	
B1,B2	1,2	3.30	B	1	20	O	N	2085	120	652		772	0.16	1834		1834	0.421	0.421		72	72	0.701	62	
B2	1,2	3.30	B	1			N	1945		818		818	0.00	1945		1945	0.421			72	72	0.700	65	
C1,C2	3	3.30	D	1	15		N	1945	185	0		185	1.00	1768		1768	0.105	0.105		18	18	0.701	31	
C2	3	3.30	D	1	20			2085		155		155	1.00	1940		1940	0.080			14	18	0.535	26	
	4		PED																20					

NOTE : 'O' - OPPOSING TRAFFIC

N - NEAR SIDE LANE

SG - STEADY GREEN

FG - FLASHING GREEN

PEDESTRIAN WALKING SPEED FOR SG(FG) = 1.2(0.9)m/s

QUEUING LENGTH = AVERAGE QUEUE * 6m

J11 - Jockey Club Road / Tin Ping Road

J11_2023_EXT_AM

PROJECT NO: 287082

Junction No. J11

DATE : 16/12/2024

FILENAME :

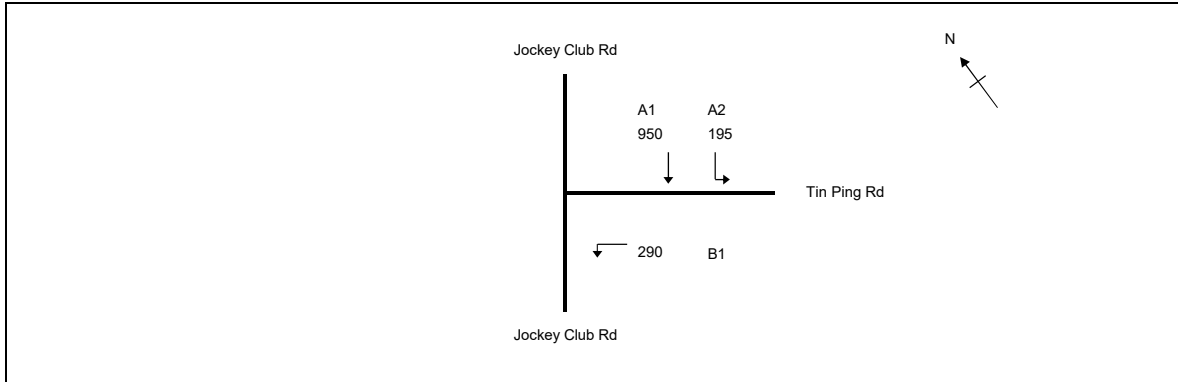

No. of stages per cycle	N =	3
No. of stage using for calculation	N =	2
Cycle time	C =	70 sec
Sum(y)	Y =	0.340
Loss time	L =	26 sec
Total Flow	=	1435 pcu
Co	= (1.5*L+5)/(1-Y)	= 66.7 sec
Cm	= L/(1-Y)	= 39.4 sec
Yult	=	0.705
R.C.ult	= (Yult-Y)/Y*100%	= 107.3 %
Cp	= 0.9*L/(0.9-Y)	= 41.8 sec
Ymax	= 1-L/C	= 0.629
R.C.(C)	= (0.9*Ymax-Y)/Y*100%	= 66 %

	A1,A2 ↓ ↓		A1 ↓	C ↑ ↓		A2 ↓			
						B1 ←			
STAGE 1	INT= 5	STAGE 2	INT= 5	STAGE 3	INT= 6	STAGE 4	INT=		

Pedestrian Phase	Width (m)	Green Time Required (s)			Green Time Provided (s)			Check
		SG	Delay	FG	SG	Delay	FG	
C	8	7	4	6	7	4	6	OK

Move-ment	Stage	Lane Width m.	Phase	No. of lane	Radius m.	O	N	Straight-Ahead Sat. Flow	Flow			Total Flow pcu/h	Proportion of Turning Vehicles	Sat. Flow pcu/h	Uphill Gradient %	Short lane Effect pcu/h	Revised Sat. Flow pcu/h	y	Greater y	L sec	g (required) sec	g (input) sec	Degree of Saturation X	Queuing Length m.
									Left pcu/h	Straight pcu/h	Right pcu/h													
A2	3	3.50	C	1	10		N	1965	195		195	1.00	1709			1709	0.114		9	15	20	0.390	16	
A1,A2	1	3.50	B	1	10		N	1965	0	357	357	0.00	1965			1965	0.182	0.182		24	24	0.541	28	
A1	1	3.50	B	1				2105		382	382	0.00	2105			2105	0.181			23	24	0.540	30	
A1	2	3.50	B	1				2105		211	211	0.00	2105			2105	0.100			13	13	0.540	20	
B1	3	3.50	D	1	10			2105	290		290	1.00	1830			1830	0.158	0.158		20	20	0.541	24	
PED	2		C																17					

NOTE : 'O' - OPPOSING TRAFFIC N - NEAR SIDE LANE SG - STEADY GREEN FG - FLASHING GREEN PEDESTRIAN WALKING SPEED FOR SG(FG) = 1.2(0.9)m/s QUEUING LENGTH = AVERAGE QUEUE * 6m

J11 - Jockey Club Road / Tin Ping Road

J11_2023_EXT_PM

PROJECT NO: 287082

Junction No. J11

DATE : 16/12/2024

FILENAME :

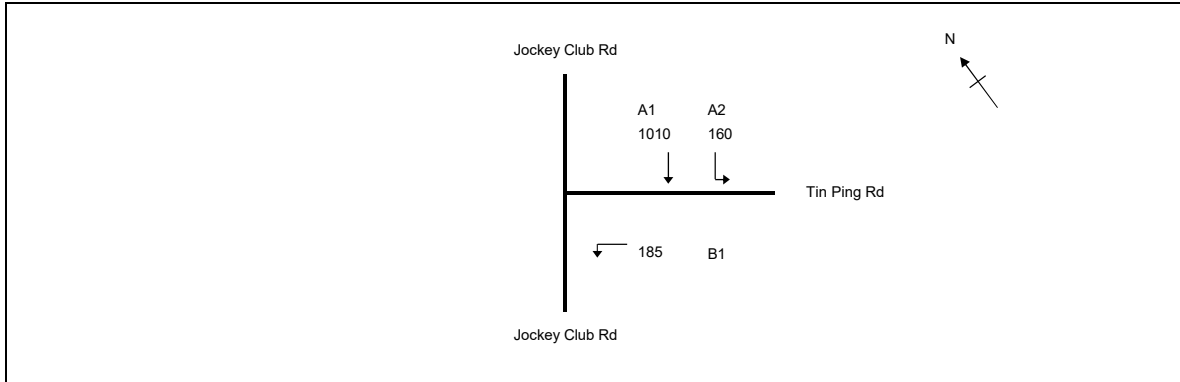

No. of stages per cycle	N =	3
No. of stage using for calculation	N =	2
Cycle time	C =	70 sec
Sum(y)	Y =	0.303
Loss time	L =	26 sec
Total Flow	=	1355 pcu
Co	= (1.5*L+5)/(1-Y)	= 63.1 sec
Cm	= L/(1-Y)	= 37.3 sec
Yult	=	0.705
R.C.ult	= (Yult-Y)/Y*100%	= 132.6 %
Cp	= 0.9*L/(0.9-Y)	= 39.2 sec
Ymax	= 1-L/C	= 0.629
R.C.(C)	= (0.9*Ymax-Y)/Y*100%	= 87 %

	A1,A2 ↓ ↓		A1 ↓	C ↑ ↓		A2 ↓			
						B1 ←			
STAGE 1	INT= 5	STAGE 2	INT= 5	STAGE 3	INT= 6	STAGE 4	INT=		

Pedestrian Phase	Width (m)	Green Time Required (s)			Green Time Provided (s)			Check
		SG	Delay	FG	SG	Delay	FG	
C	8	7	4	6	7	4	6	OK

Move-ment	Stage	Lane Width m.	Phase	No. of lane	Radius m.	O	N	Straight-Ahead Sat. Flow	Flow			Total Flow pcu/h	Proportion of Turning Vehicles	Sat. Flow pcu/h	Uphill Gradient %	Short lane Effect pcu/h	Revised Sat. Flow pcu/h	y	Greater y	L sec	g (required) sec	g (input) sec	Degree of Saturation X	Queuing Length m.
									Left pcu/h	Straight pcu/h	Right pcu/h													
A2	3	3.50	C	1	10		N	1965	160		160	1.00	1709			1709	0.094		9	14	15	0.447	15	
A1,A2	1	3.50	B	1	10		N	1965	0	397	397	0.00	1965			1965	0.202	0.202		29	29	0.482	27	
A1	1	3.50	B	1				2105		425	425	0.00	2105			2105	0.202			29	29	0.482	29	
A1	2	3.50	B	1				2105		188	188	0.00	2105			2105	0.089			13	13	0.481	18	
B1	3	3.50	D	1	10			2105	185		185	1.00	1830			1830	0.101	0.101		15	15	0.482	17	
PED	2		C																17					

NOTE : 'O' - OPPOSING TRAFFIC N - NEAR SIDE LANE SG - STEADY GREEN FG - FLASHING GREEN PEDESTRIAN WALKING SPEED FOR SG(FG) = 1.2(0.9)m/s QUEUING LENGTH = AVERAGE QUEUE * 6m

J11 - Jockey Club Road / Tin Ping Road

J11_2031_REF_AM

PROJECT NO: 287082

Junction No. J11

DATE : 16/12/2024

FILENAME :

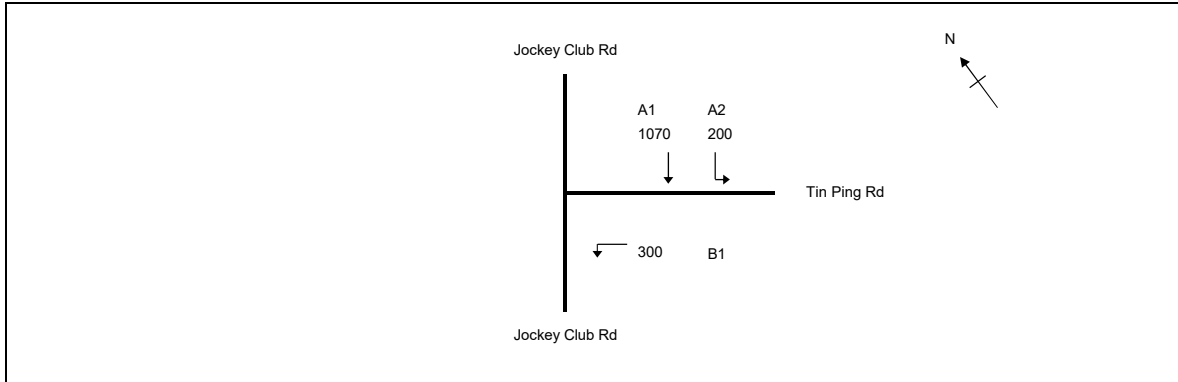

No. of stages per cycle	N =	3
No. of stage using for calculation	N =	2
Cycle time	C =	70 sec
Sum(y)	Y =	0.371
Loss time	L =	26 sec
Total Flow	=	1570 pcu
Co	= (1.5*L+5)/(1-Y)	= 69.9 sec
Cm	= L/(1-Y)	= 41.3 sec
Yult	=	0.705
R.C.ult	= (Yult-Y)/Y*100%	= 90.3 %
Cp	= 0.9*L/(0.9-Y)	= 44.2 sec
Ymax	= 1-L/C	= 0.629
R.C.(C)	= (0.9*Ymax-Y)/Y*100%	= 52 %

	A1,A2 ↓ ↓		A1 ↓	C ↑ ↓		A2 ↓			
						B1 ←			
STAGE 1	INT= 5	STAGE 2	INT= 5	STAGE 3	INT= 6	STAGE 4	INT=		

Pedestrian Phase	Width (m)	Green Time Required (s)			Green Time Provided (s)			Check
		SG	Delay	FG	SG	Delay	FG	
C	8	7	4	6	7	4	6	OK

Move-ment	Stage	Lane Width m.	Phase	No. of lane	Radius m.	O	N	Straight-Ahead Sat. Flow	Flow			Total Flow pcu/h	Proportion of Turning Vehicles	Sat. Flow pcu/h	Uphill Gradient %	Short lane Effect pcu/h	Revised Sat. Flow pcu/h	y	Greater y	L sec	g (required) sec	g (input) sec	Degree of Saturation X	Queuing Length m.
									Left pcu/h	Straight pcu/h	Right pcu/h													
A2	3	3.50	C	1	10		N	1965	200		200	1.00	1709			1709	0.117		9	14	19	0.421	17	
A1,A2	1	3.50	B	1	10		N	1965	0	405	405	0.00	1965			1965	0.206	0.207		24	25	0.588	31	
A1	1	3.50	B	1				2105		435	435	0.00	2105			2105	0.207			25	25	0.590	33	
A1	2	3.50	B	1				2105		230	230	0.00	2105			2105	0.109			13	13	0.588	22	
B1	3	3.50	D	1	10			2105	300	0	300	1.00	1830			1830	0.164	0.164		19	19	0.590	25	
PED	2		C																17					

NOTE : 'O' - OPPOSING TRAFFIC

N - NEAR SIDE LANE

SG - STEADY GREEN

FG - FLASHING GREEN

PEDESTRIAN WALKING SPEED FOR SG(FG) = 1.2(0.9)m/s

QUEUING LENGTH = AVERAGE QUEUE * 6m

OVE ARUP & PARTNERS

TRAFFIC SIGNAL CALCULATION

J11 - Jockey Club Road / Tin Ping Road

J11_2031_REF_PM

PROJECT NO: 287082

Junction No. J11

DATE : 16/12/2024

FILENAME :

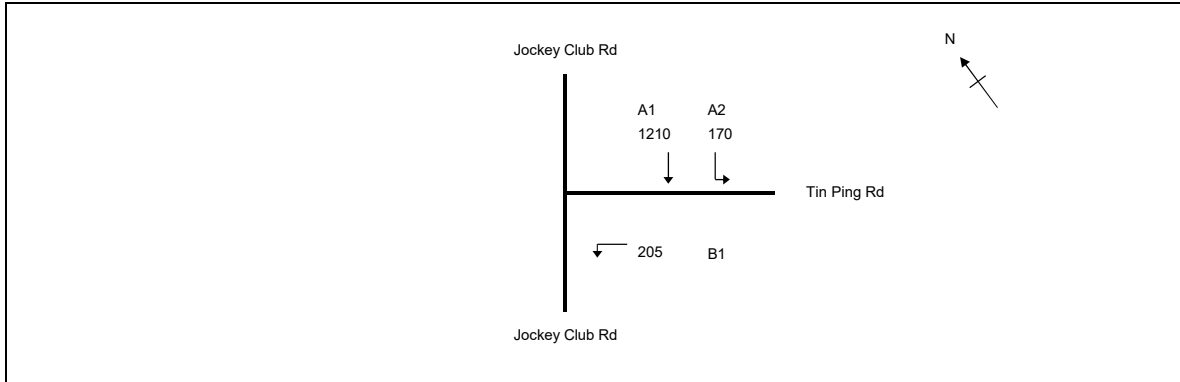

No. of stages per cycle	N =	3
No. of stage using for calculation	N =	2
Cycle time	C =	70 sec
Sum(y)	Y =	0.369
Loss time	L =	26 sec
Total Flow	=	1585 pcu
Co	= (1.5*L+5)/(1-Y)	= 69.7 sec
Cm	= L/(1-Y)	= 41.2 sec
Yult	=	0.705
R.C.ult	= (Yult-Y)/Y*100%	= 91.1 %
Cp	= 0.9*L/(0.9-Y)	= 44.1 sec
Ymax	= 1-L/C	= 0.629
R.C.(C)	= (0.9*Ymax-Y)/Y*100%	= 53 %

	A1,A2 ↓ ↓		A1 ↓	C ↑ ↓		A2 ↓			
							B1 ←		
STAGE 1	INT= 5	STAGE 2	INT= 5	STAGE 3	INT= 6	STAGE 4	INT=		

Pedestrian Phase	Width (m)	Green Time Required (s)			Green Time Provided (s)			Check
		SG	Delay	FG	SG	Delay	FG	
C	8	7	4	6	7	4	6	OK

Move-ment	Stage	Lane Width m.	Phase	No. of lane	Radius m.	O	N	Straight-Ahead Sat. Flow	Flow			Total Flow pcu/h	Proportion of Turning Vehicles	Sat. Flow pcu/h	Uphill Gradient %	Short lane Effect pcu/h	Revised Sat. Flow pcu/h	y	Greater y	L sec	g (required) sec	g (input) sec	Degree of Saturation X	Queuing Length m.
									Left pcu/h	Straight pcu/h	Right pcu/h													
A2	3	3.50	C	1	10		N	1965	118		118	1.00	1709			1709	0.069		9	8	13	0.362	11	
A1,A2	1	3.50	B	1	10		N	1965	52	445	497	0.10	1935			1935	0.257	0.257		31	31	0.587	33	
A1	1	3.50	B	1				2105		541	541	0.00	2105			2105	0.257			31	31	0.587	35	
A1	2	3.50	B	1				2105		224	224	0.00	2105			2105	0.106			13	13	0.573	21	
B1	3	3.50	D	1	10			2105	205	0	0	1.00	1830			1830	0.112	0.112		13.4	13.4	0.587	19	
PED	2		C																17					

NOTE : 'O' - OPPOSING TRAFFIC

N - NEAR SIDE LANE

SG - STEADY GREEN

FG - FLASHING GREEN

PEDESTRIAN WALKING SPEED FOR SG(FG) = 1.2(0.9)m/s

QUEUING LENGTH = AVERAGE QUEUE * 6m

J11 - Jockey Club Road / Tin Ping Road

J11_2031_DES_AM

PROJECT NO: 287082

Junction No. J11

DATE : 16/12/2024

FILENAME :

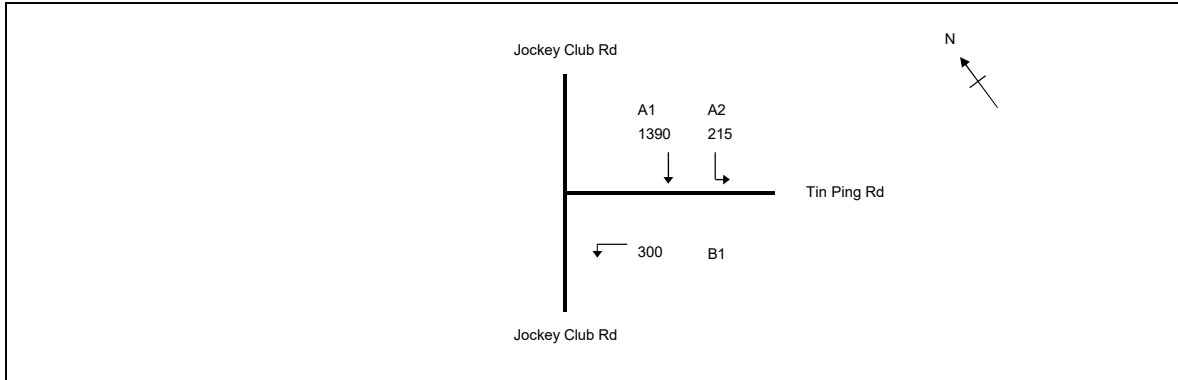

No. of stages per cycle	N =	3
No. of stage using for calculation	N =	2
Cycle time	C =	70 sec
Sum(y)	Y =	0.439
Loss time	L =	26 sec
Total Flow	=	1905 pcu
Co	= (1.5*L+5)/(1-Y)	= 78.4 sec
Cm	= L/(1-Y)	= 46.3 sec
Yult	=	0.705
R.C.ult	= (Yult-Y)/Y*100%	= 60.7 %
Cp	= 0.9*L/(0.9-Y)	= 50.7 sec
Ymax	= 1-L/C	= 0.629
R.C.(C)	= (0.9*Ymax-Y)/Y*100%	= 28 %

	A1,A2 ↓ ↓		A1 ↓	C ↑ ↓		A2 ↓			
						B1 ←			
STAGE 1	INT= 5	STAGE 2	INT= 5	STAGE 3	INT= 6	STAGE 4	INT=		

Pedestrian Phase	Width (m)	Green Time Required (s)			Green Time Provided (s)			Check
		SG	Delay	FG	SG	Delay	FG	
C	8	7	4	6	7	4	6	OK

Move-ment	Stage	Lane Width m.	Phase	No. of lane	Radius m.	O	N	Straight-Ahead Sat. Flow	Flow			Total Flow pcu/h	Proportion of Turning Vehicles	Sat. Flow pcu/h	Uphill Gradient %	Short lane Effect pcu/h	Revised Sat. Flow pcu/h	y	Greater y	L sec	g (required) sec	g (input) sec	Degree of Saturation X	Queuing Length m.
									Left pcu/h	Straight pcu/h	Right pcu/h													
A2	3	3.50	C	1	10		N	1965	215		215	1.00	1709			1709	0.126		9	13	16	0.536	19	
A1,A2	1	3.50	B	1	10		N	1965	0	540	540	0.00	1965			1965	0.275	0.275		28	28	0.698	38	
A1	1	3.50	B	1				2105		578	578	0.00	2105			2105	0.275			28	28	0.697	41	
A1	2	3.50	B	1				2105		272	272	0.00	2105			2105	0.129			13	13	0.696	26	
B1	3	3.50	D	1	10			2105	300	0	300	1.00	1830			1830	0.164	0.164		16	16	0.698	27	
PED	2		C																17					

NOTE : 'O' - OPPOSING TRAFFIC

N - NEAR SIDE LANE

SG - STEADY GREEN

FG - FLASHING GREEN

PEDESTRIAN WALKING SPEED FOR SG(FG) = 1.2(0.9)m/s

QUEUING LENGTH = AVERAGE QUEUE * 6m

J11 - Jockey Club Road / Tin Ping Road

J11_2031_DES_PM

PROJECT NO: 287082

Junction No. J11

DATE : 16/12/2024

FILENAME :

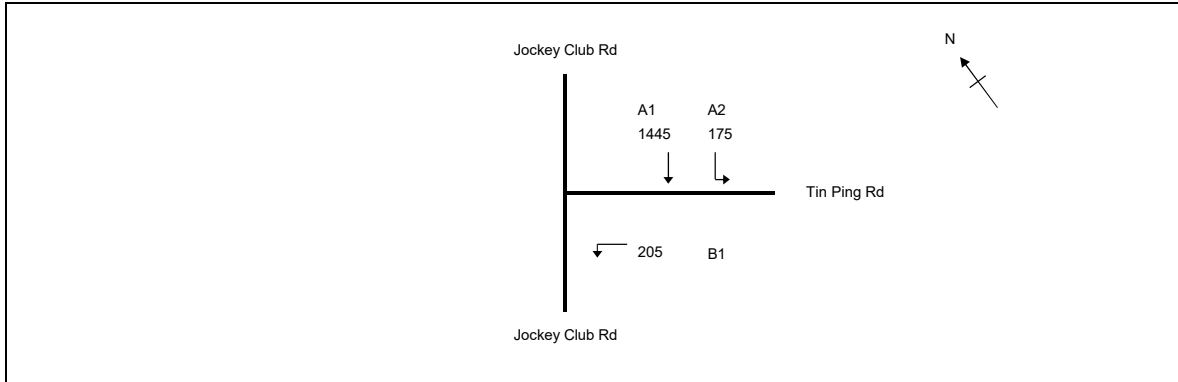

No. of stages per cycle	N = 3
No. of stage using for calculation	N = 2
Cycle time	C = 70 sec
Sum(y)	Y = 0.406
Loss time	L = 26 sec
Total Flow	= 1825 pcu
Co = (1.5*L+5)/(1-Y)	= 74.0 sec
Cm = L/(1-Y)	= 43.7 sec
Yult = (Yult-Y)/Y*100%	= 0.705
R.C.ult = (Yult-Y)/Y*100%	= 73.8 %
Cp = 0.9*L/(0.9-Y)	= 47.3 sec
Ymax = 1-L/C	= 0.629
R.C.(C) = (0.9*Ymax-Y)/Y*100%	= 39 %

	A1,A2 ↓ ↓		A1 ↓	C ↑ ↓		A2 ↓			
							B1 ←		
STAGE 1	INT= 5	STAGE 2	INT= 5	STAGE 3	INT= 6	STAGE 4	INT=		

Pedestrian Phase	Width (m)	Green Time Required (s)			Green Time Provided (s)			Check
		SG	Delay	FG	SG	Delay	FG	
C	8	7	4	6	7	4	6	OK

Move-ment	Stage	Lane Width m.	Phase	No. of lane	Radius m.	O	N	Straight-Ahead Sat. Flow	Flow			Total Flow pcu/h	Proportion of Turning Vehicles	Sat. Flow pcu/h	Uphill Gradient %	Short lane Effect pcu/h	Revised Sat. Flow pcu/h	y	Greater y	L sec	g (required) sec	g (input) sec	Degree of Saturation X	Queuing Length m.
									Left pcu/h	Straight pcu/h	Right pcu/h													
A2	3	3.50	C	1	10		N	1965	175		175	1.00	1709			1709	0.102		9	11	12	0.590	17	
A1,A2	1	3.50	B	1	10		N	1965	0	576	576	0.00	1965			1965	0.293	0.294		32	32	0.644	37	
A1	1	3.50	B	1				2105		618	618	0.00	2105			2105	0.294			32	32	0.645	39	
A1	2	3.50	B	1				2105		251	251	0.00	2105			2105	0.119			13	13	0.642	24	
B1	3	3.50	D	1	10			2105	205	0	0	1.00	1830			1830	0.112	0.112		12	12	0.645	20	
PED	2		C																17					

NOTE : 'O' - OPPOSING TRAFFIC

N - NEAR SIDE LANE

SG - STEADY GREEN

FG - FLASHING GREEN

PEDESTRIAN WALKING SPEED FOR SG(FG) = 1.2(0.9)m/s

QUEUING LENGTH = AVERAGE QUEUE * 6m

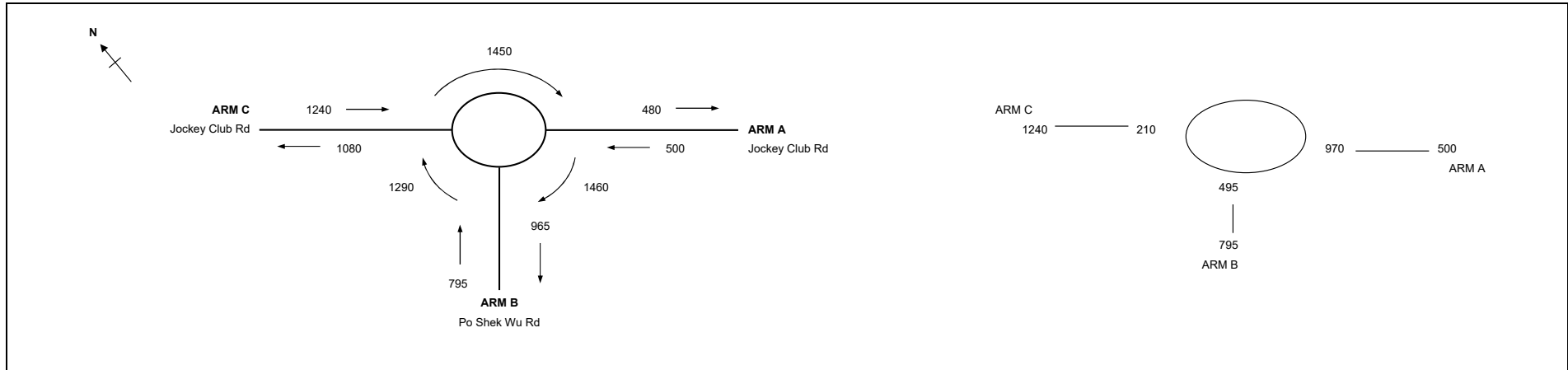

ARM	A	B	C
INPUT PARAMETERS:			
V = Approach half width (m)	7.50	7.00	7.50
E = Entry width (m)	10.50	10.50	10.00
L = Effective length of flare (m)	10	10	10
R = Entry radius (m)	10	90	100
D = Inscribed circle diameter (m)	40	40	40
A = Entry angle (degree)	30	20	10
Q = Entry flow (pcu/h)	500	795	1240
Qc = Circulating flow across entry (pcu/h)	970	495	210
OUTPUT PARAMETERS:			
S = Sharpness of flare = 1.6(E-V)/L	0.48	0.56	0.40
K = 1-0.00347(A-30)-0.978(1/R-0.05)	0.95	1.07	1.11
X2 = V + ((E-V)/(1+2S))	9.03	8.65	8.89
M = EXP((D-60)/10)	0.14	0.14	0.14
F = 303*X2	2736	2621	2693
Td = 1+(0.5/(1+M))	1.44	1.44	1.44
Fc = 0.21*Td(1+0.2*X2)	0.85	0.83	0.84
Qe = K(F-Fc*Qc)	1819	2373	2790
DFC = Design flow/Capacity = Q/Qe	0.27	0.33	0.44
Total In Sum =			2535 PCU
DFC of Critical Approach =			0.44

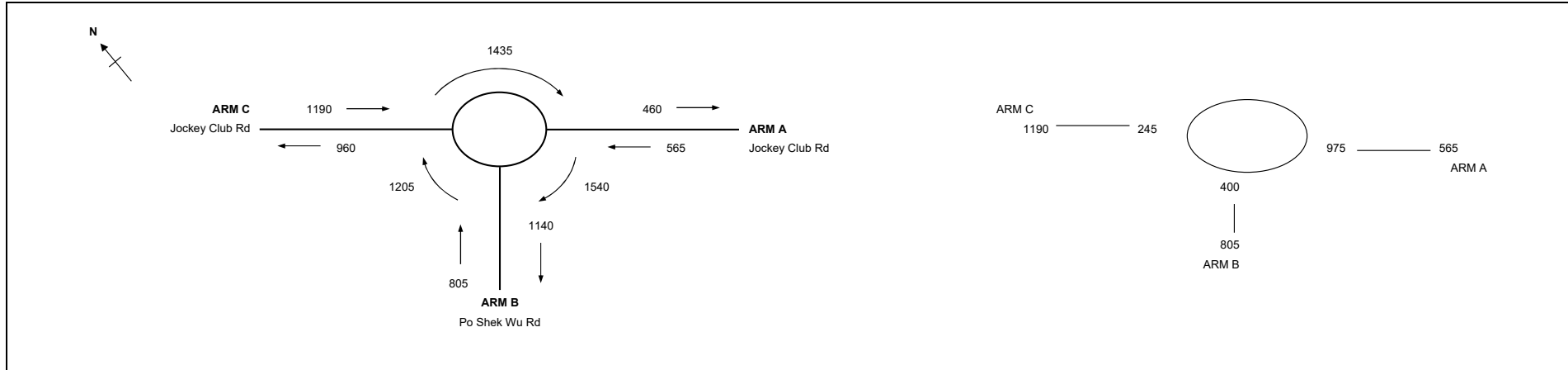

ARM	A	B	C
INPUT PARAMETERS:			
V = Approach half width (m)	7.50	7.00	7.50
E = Entry width (m)	10.50	10.50	10.00
L = Effective length of flare (m)	10	10	10
R = Entry radius (m)	10	90	100
D = Inscribed circle diameter (m)	40	40	40
A = Entry angle (degree)	30	20	10
Q = Entry flow (pcu/h)	565	805	1190
Qc = Circulating flow across entry (pcu/h)	975	400	245
OUTPUT PARAMETERS:			
S = Sharpness of flare = 1.6(E-V)/L	0.48	0.56	0.40
K = 1-0.00347(A-30)-0.978(1/R-0.05)	0.95	1.07	1.11
X2 = $V + ((E-V)/(1+2S))$	9.03	8.65	8.89
M = $EXP((D-60)/10)$	0.14	0.14	0.14
F = 303*X2	2736	2621	2693
Td = 1+(0.5/(1+M))	1.44	1.44	1.44
Fc = 0.21*Td(1+0.2*X2)	0.85	0.83	0.84
Qe = K(F-Fc*Qc)	1815	2458	2757
DFC = Design flow/Capacity = Q/Qe	0.31	0.33	0.43
Total In Sum =		2560	PCU
DFC of Critical Approach =		0.43	

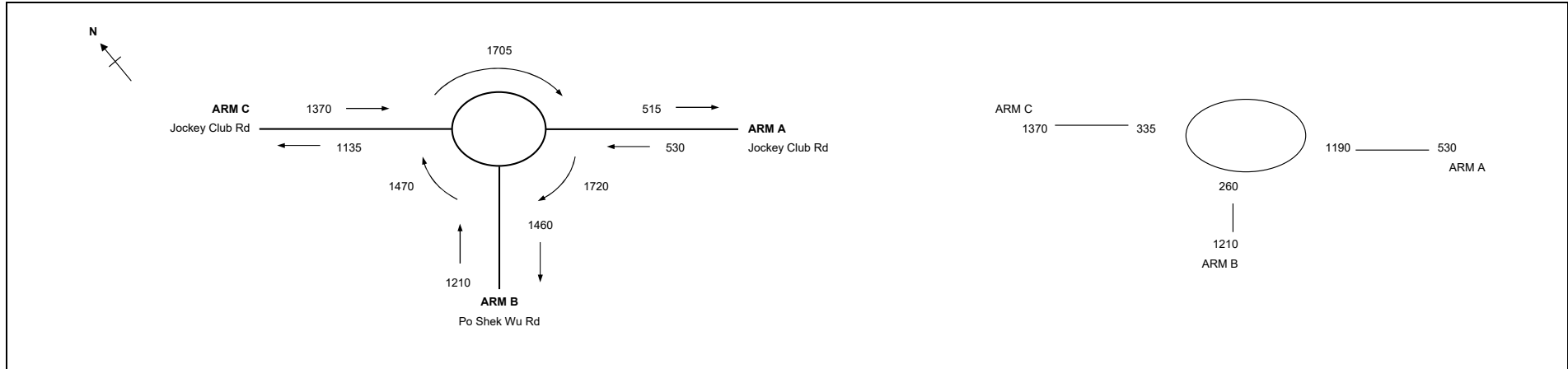

ARM	A	B	C
INPUT PARAMETERS:			
V = Approach half width (m)	7.50	7.00	7.50
E = Entry width (m)	10.50	10.50	10.00
L = Effective length of flare (m)	10	10	10
R = Entry radius (m)	10	90	100
D = Inscribed circle diameter (m)	40	40	40
A = Entry angle (degree)	30	20	10
Q = Entry flow (pcu/h)	530	1210	1370
Qc = Circulating flow across entry (pcu/h)	1190	260	335
OUTPUT PARAMETERS:			
S = Sharpness of flare = 1.6(E-V)/L	0.48	0.56	0.40
K = 1-0.00347(A-30)-0.978(1/R-0.05)	0.95	1.07	1.11
X2 = V + ((E-V)/(1+2S))	9.03	8.65	8.89
M = EXP((D-60)/10)	0.14	0.14	0.14
F = 303*X2	2736	2621	2693
Td = 1+(0.5/(1+M))	1.44	1.44	1.44
Fc = 0.21*Td(1+0.2*X2)	0.85	0.83	0.84
Qe = K(F-Fc*Qc)	1642	2582	2674
DFC = Design flow/Capacity = Q/Qe	0.33	0.47	0.52
Total In Sum =		3110	PCU
DFC of Critical Approach =		0.52	

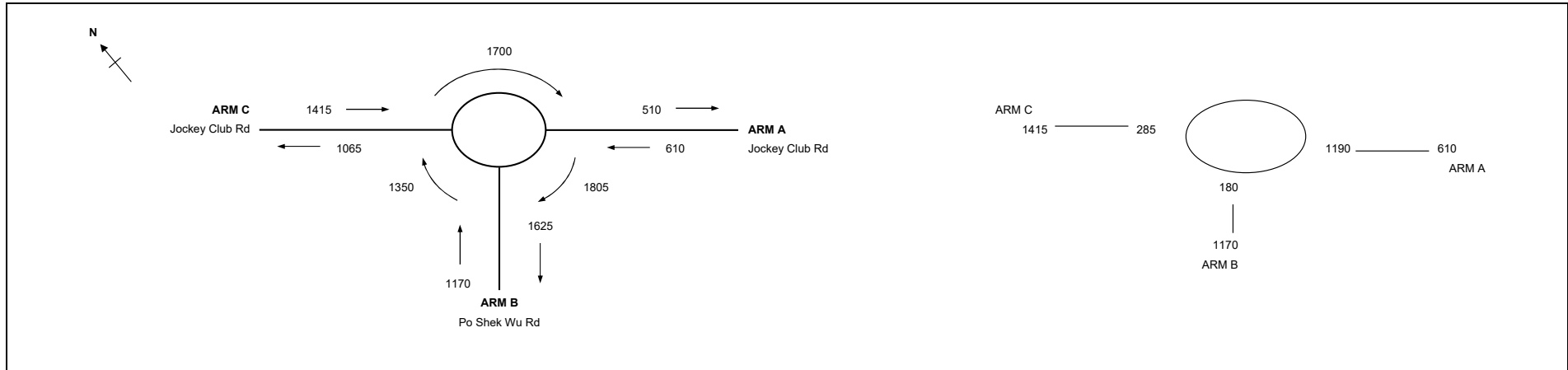

ARM	A	B	C		
INPUT PARAMETERS:					
V = Approach half width (m)	7.50	7.00	7.50		
E = Entry width (m)	10.50	10.50	10.00		
L = Effective length of flare (m)	10	10	10		
R = Entry radius (m)	10	90	100		
D = Inscribed circle diameter (m)	40	40	40		
A = Entry angle (degree)	30	20	10		
Q = Entry flow (pcu/h)	610	1170	1415		
Qc = Circulating flow across entry (pcu/h)	1190	180	285		
OUTPUT PARAMETERS:					
S = Sharpness of flare = 1.6(E-V)/L	0.48	0.56	0.40		
K = 1-0.00347(A-30)-0.978(1/R-0.05)	0.95	1.07	1.11		
X2 = $V + ((E-V)/(1+2S))$	9.03	8.65	8.89		
M = $EXP((D-60)/10)$	0.14	0.14	0.14		
F = 303*X2	2736	2621	2693		
Td = 1+(0.5/(1+M))	1.44	1.44	1.44		
Fc = 0.21*Td(1+0.2*X2)	0.85	0.83	0.84		
Qe = K(F-Fc*Qc)	1642	2652	2720		
DFC = Design flow/Capacity = Q/Qe	0.38	0.45	0.53		
				Total In Sum =	3195 PCU
				DFC of Critical Approach =	0.53

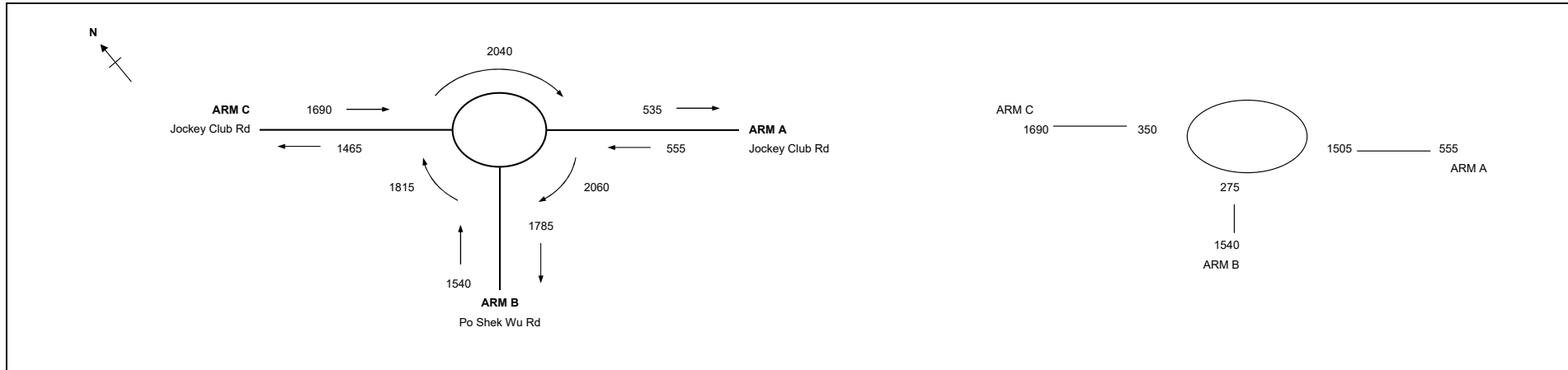

ARM	A	B	C
INPUT PARAMETERS:			
V = Approach half width (m)	7.50	7.00	7.50
E = Entry width (m)	10.50	10.50	10.00
L = Effective length of flare (m)	10	10	10
R = Entry radius (m)	10	90	100
D = Inscribed circle diameter (m)	40	40	40
A = Entry angle (degree)	30	20	10
Q = Entry flow (pcu/h)	555	1540	1690
Qc = Circulating flow across entry (pcu/h)	1505	275	350
OUTPUT PARAMETERS:			
S = Sharpness of flare = $1.6(E-V)/L$	0.48	0.56	0.40
K = $1-0.00347(A-30)-0.978(1/R-0.05)$	0.95	1.07	1.11
X2 = $V + ((E-V)/(1+2S))$	9.03	8.65	8.89
M = $EXP((D-60)/10)$	0.14	0.14	0.14
F = $303 \times X2$	2736	2621	2693
Td = $1+(0.5/(1+M))$	1.44	1.44	1.44
Fc = $0.21 \times Td(1+0.2 \times X2)$	0.85	0.83	0.84
Qe = $K(F-Fc \times Qc)$	1387	2568	2660
DFC = Design flow/Capacity = Q/Qe	0.41	0.60	0.64
Total In Sum =			3785 PCU
DFC of Critical Approach =			0.64

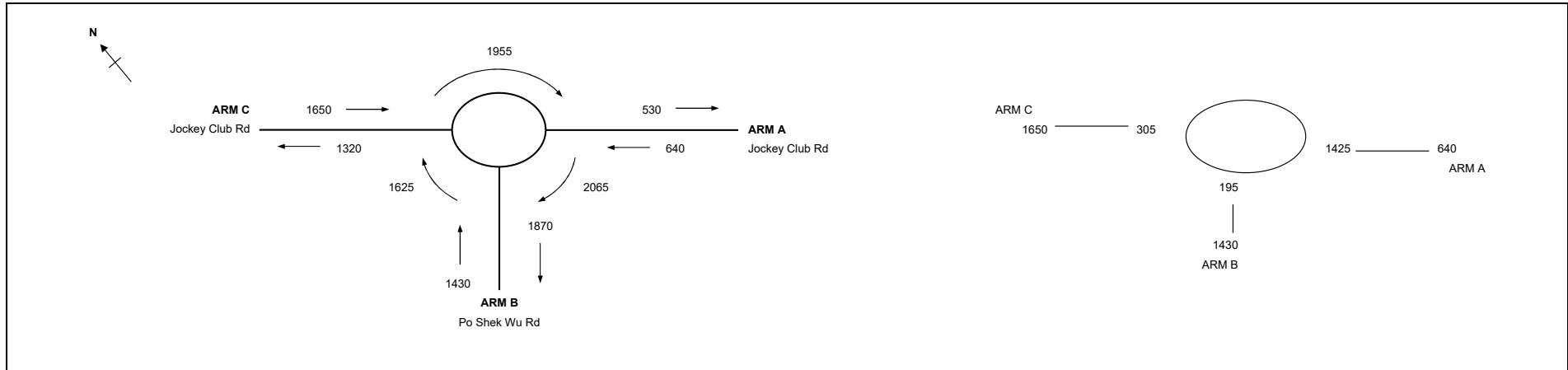

ARM	A	B	C		
INPUT PARAMETERS:					
V =	Approach half width (m)	7.50	7.00	7.50	
E =	Entry width (m)	10.50	10.50	10.00	
L =	Effective length of flare (m)	10	10	10	
R =	Entry radius (m)	10	90	100	
D =	Inscribed circle diameter (m)	40	40	40	
A =	Entry angle (degree)	30	20	10	
Q =	Entry flow (pcu/h)	640	1430	1650	
Qc =	Circulating flow across entry (pcu/h)	1425	195	305	
OUTPUT PARAMETERS:					
S =	Sharpness of flare = $1.6(E-V)/L$	0.48	0.56	0.40	
K =	$1-0.00347(A-30)-0.978(1/R-0.05)$	0.95	1.07	1.11	
X2 =	$V + ((E-V)/(1+2S))$	9.03	8.65	8.89	
M =	$EXP((D-60)/10)$	0.14	0.14	0.14	
F =	$303 \times X2$	2736	2621	2693	
Td =	$1+(0.5/(1+M))$	1.44	1.44	1.44	
Fc =	$0.21 \times Td(1+0.2 \times X2)$	0.85	0.83	0.84	
Qe =	$K(F-Fc \times Qc)$	1452	2639	2702	
DFC =	Design flow/Capacity = Q/Qe	0.45	0.55	0.62	
Total In Sum =					3720 PCU
DFC of Critical Approach =					0.62

J13 - Po Shek Wu Road / Po Wan Road

J13_2023_EXT_AM

PROJECT NO:

Junction No. J13

DATE : 16/12/2024

FILENAME :

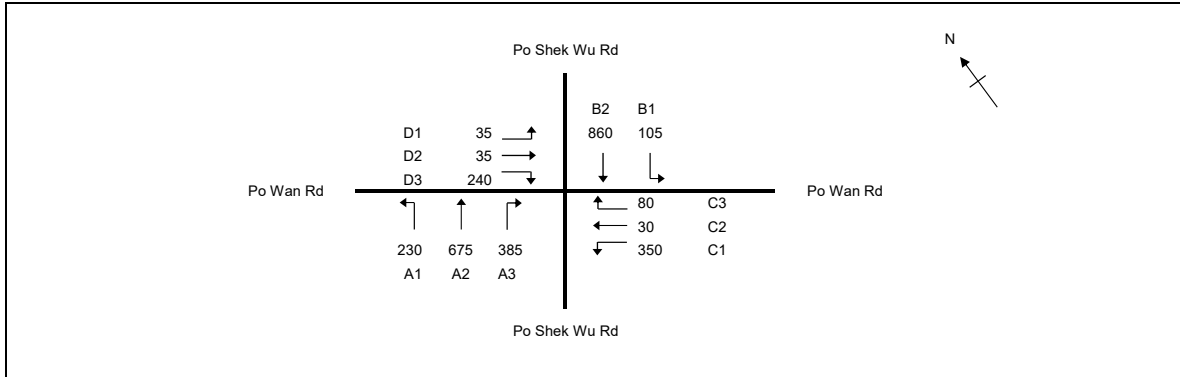

No. of stages per cycle	N = 4
No. of stage using for calculation	N = 2
Cycle time	C = 128 sec
Sum(y)	Y = 0.324
Loss time	L = 62 sec
Total Flow	= 3025 pcu
Co = (1.5*L+5)/(1-Y)	= 145.0 sec
Cm = L/(1-Y)	= 91.8 sec
Yult	= 0.435
R.C.ult = (Yult-Y)/Y*100%	= 34.1 %
Cp = 0.9*L/(0.9-Y)	= 96.9 sec
Ymax = 1-L/C	= 0.516
R.C.(C) = (0.9*Ymax-Y)/Y*100%	= 43 %

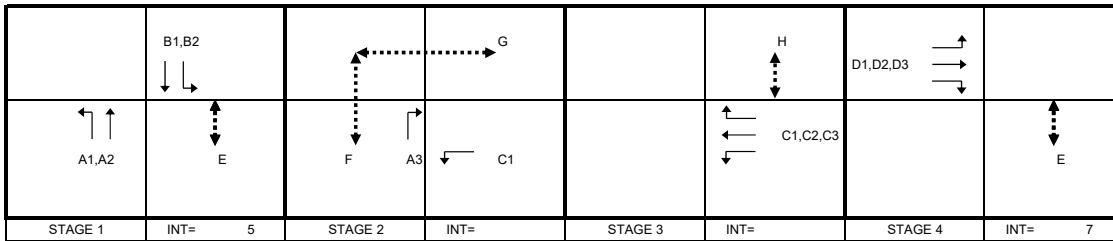

Pedestrian Phase	Width (m)	Green Time Required (s)		Green Time Provided (s)			Check	
		SG	Delay	FG	SG	Delay		FG
E	8	6	2	9	64	2	9	OK
F	8	7	6	7	15	6	7	OK
G	12	10	6	12	10	6	12	OK
H	7	6	10	8	6	10	8	OK

Movement	Stage	Lane Width m.	Phase	No. of lane	Radius m.	O	N	Straight-Ahead Sat. Flow	Flow			Total Flow pcu/h	Proportion of Turning Vehicles	Sat. Flow pcu/h	Uphill Gradient %	Short lane Effect pcu/h	Revised Sat. Flow pcu/h	y	Greater y	L sec	g (required) sec	g (input) sec	Degree of Saturation X	Queuing Length m.
									Left pcu/h	Straight pcu/h	Right pcu/h													
A1	1	3.30	A	1	15		N	1945	230			230	1.00	1768		1768	0.130	0.202	10	26	41	0.406	33	
A2	1	3.30	A	2				4170		675		675	0.00	4170		4170	0.162			33	41	0.505	49	
B1	1	3.70	B	1	15			2125	105			105	1.00	1932		1932	0.054			11	41	0.170	15	
B2	1	3.70	A	2				4250		860		860	0.00	4250		4250	0.202			41	41	0.632	62	
A3	2	3.30	A	2	15			4170		385		385	1.00	3791		3791	0.102			21	23	0.565	34	
C1	2,3	3.50	B	1	15		N	1965	350			350	1.00	1786		1786	0.196			40	44	0.570	49	
C2,C3	3	3.30	C,D	1	20			2085		30	80	110	0.73	1977		1977	0.056			11	18	0.396	20	
D1,D2	4	3.30	D	1	15		N	1945	35	35		70	0.50	1852		1852	0.038	0.122		8	25	0.193	12	
D3	4	3.30	E	1	25			2085			240	240	1.00	1967		1967	0.122			25	25	0.625	41	
PED	2		G																28					
PED	3		H																24					

NOTE : 'O' - OPPOSING TRAFFIC N - NEAR SIDE LANE SG - STEADY GREEN FG - FLASHING GREEN PEDESTRIAN WALKING SPEED FOR SG(FG) = 1.2(0.9)m/s QUEUING LENGTH = AVERAGE QUEUE * 6m

J13 - Po Shek Wu Road / Po Wan Road

J13_2023_EXT_PM

PROJECT NO:

Junction No. J13

DATE : 16/12/2024

FILENAME :

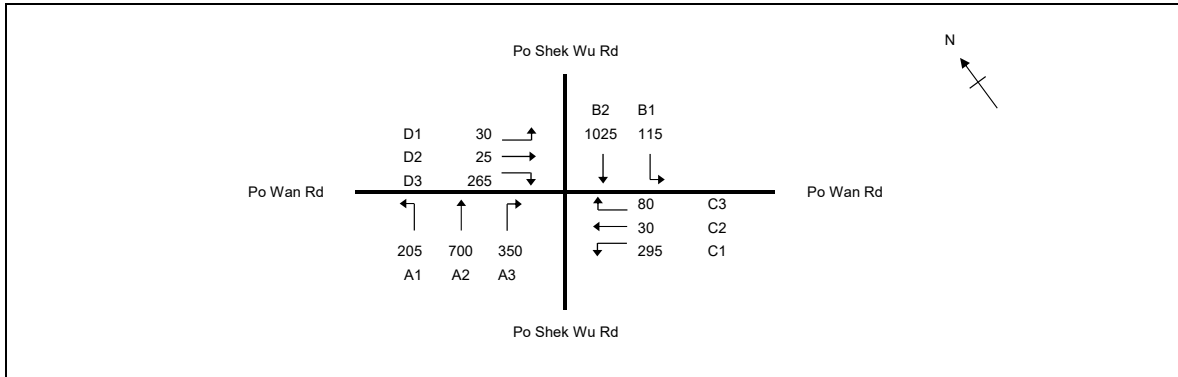

No. of stages per cycle	N = 4
No. of stage using for calculation	N = 2
Cycle time	C = 128 sec
Sum(y)	Y = 0.376
Loss time	L = 62 sec
Total Flow	= 3120 pcu
Co = (1.5*L+5)/(1-Y)	= 157.0 sec
Cm = L/(1-Y)	= 99.3 sec
Yult	= 0.435
R.C.ult = (Yult-Y)/Y*100%	= 15.7 %
Cp = 0.9*L/(0.9-Y)	= 106.5 sec
Ymax = 1-L/C	= 0.516
R.C.(C) = (0.9*Ymax-Y)/Y*100%	= 23 %

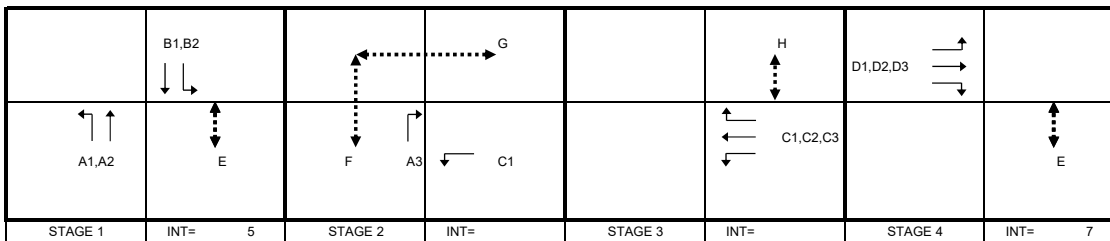

Pedestrian Phase	Width (m)	Green Time Required (s)			Green Time Provided (s)			Check
		SG	Delay	FG	SG	Delay	FG	
E	8	6	2	9	64	2	9	OK
F	8	7	6	7	15	6	7	OK
G	12	10	6	12	10	6	12	OK
H	7	6	10	8	6	10	8	OK

Move-ment	Stage	Lane Width m.	Phase	No. of lane	Radius m.	O	N	Straight-Ahead Sat. Flow	Flow			Total Flow pcu/h	Proportion of Turning Vehicles	Sat. Flow pcu/h	Uphill Gradient %	Short lane Effect pcu/h	Revised Sat. Flow pcu/h	y	Greater y	L sec	g (required) sec	g (input) sec	Degree of Saturation X	Queuing Length m.
									Left pcu/h	Straight pcu/h	Right pcu/h													
A1	1	3.30	A	1	15		N	1945	205			205	1.00	1768		1768	0.116	0.241	10	20	42	0.353	29	
A2	1	3.30	A	2				4170		700		700	0.00	4170		4170	0.168			29	42	0.512	50	
B1	1	3.70	B	1	15			2125	115			115	1.00	1932		1932	0.060			10	42	0.181	16	
B2	1	3.70	A	2				4250		1025		1025	0.00	4250		4250	0.241			42	42	0.735	73	
A3	2	3.30	A	2	15			4170		350		350	1.00	3791		3791	0.092			16	23	0.514	31	
C1	2,3	3.50	B	1	15		N	1965	295			295	1.00	1786		1786	0.165			29	44	0.480	41	
C2,C3	3	3.30	C,D	1	20			2085		30	80	110	0.73	1977		1977	0.056			10	18	0.396	20	
D1,D2	4	3.30	D	1	15		N	1945	30	25		55	0.55	1844		1844	0.030	0.135		5	24	0.159	10	
D3	4	3.30	E	1	25			2085			265	265	1.00	1967		1967	0.135			24	24	0.719	46	
PED	2		G																28					
PED	3		H																24					

NOTE : 'O' - OPPOSING TRAFFIC N - NEAR SIDE LANE SG - STEADY GREEN FG - FLASHING GREEN PEDESTRIAN WALKING SPEED FOR SG(FG) = 1.2(0.9)m/s QUEUING LENGTH = AVERAGE QUEUE * 6m

J13 - Po Shek Wu Road / Po Wan Road

J13_2031_REF_AM

PROJECT NO:

Junction No. J13

DATE : 16/12/2024

FILENAME :

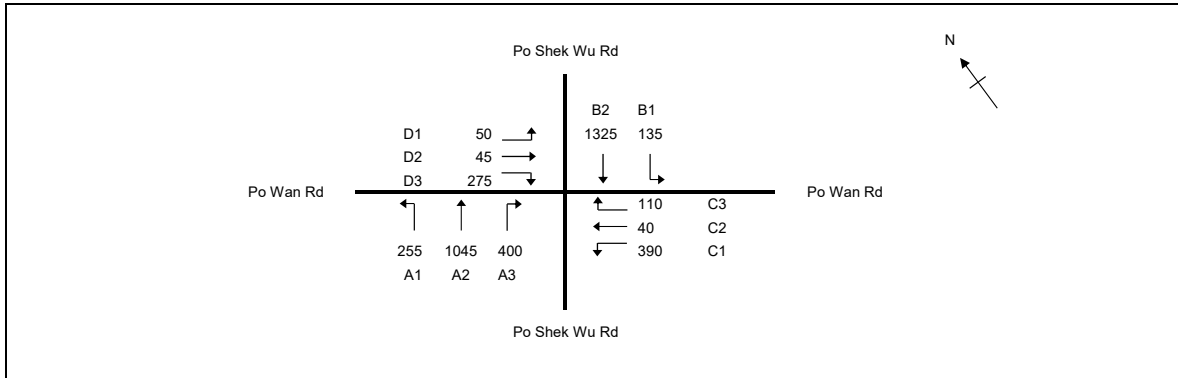

No. of stages per cycle	N = 4
No. of stage using for calculation	N = 2
Cycle time	C = 128 sec
Sum(y)	Y = 0.349
Loss time	L = 62 sec
Total Flow	= 4070 pcu
Co	= (1.5*L+5)/(1-Y) = 150.5 sec
Cm	= L/(1-Y) = 95.2 sec
Yult	= 0.435
R.C.ult	= (Yult-Y)/Y*100% = 24.7 %
Cp	= 0.9*L/(0.9-Y) = 101.3 sec
Ymax	= 1-L/C = 0.516
R.C.(C)	= (0.9*Ymax-Y)/Y*100% = 32 %

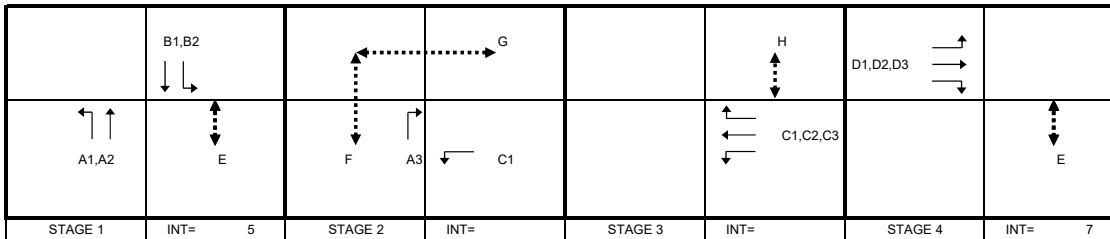

Pedestrian Phase	Width (m)	Green Time Required (s)			Green Time Provided (s)			Check
		SG	Delay	FG	SG	Delay	FG	
E	8	6	2	9	65	2	9	OK
F	8	7	6	7	15	6	7	OK
G	12	10	6	12	10	6	12	OK
H	7	6	10	8	6	10	8	OK

Movement	Stage	Lane Width m.	Phase	No. of lane	Radius m.	O	N	Straight-Ahead Sat. Flow	Flow			Total Flow pcu/h	Proportion of Turning Vehicles	Sat. Flow pcu/h	Uphill Gradient %	Short lane Effect pcu/h	Revised Sat. Flow pcu/h	y	Greater y	L sec	g (required) sec	g (input) sec	Degree of Saturation X	Queuing Length m.
									Left pcu/h	Straight pcu/h	Right pcu/h													
A1	1	3.30	A	1	15		N	1945	255			255	1.00	1768		1768	0.144	0.251	10	27	47	0.389	34	
A1,A2	1	3.30	A	1	20			2085	0	522		522	0.00	2085		2085	0.250			47	47	0.675	70	
A2	1	3.30	A	1				2085		523		523	0.00	2085		2085	0.251			47	47	0.677	70	
B1,B2	1	3.70	A	1	15			2125	135	343		478	0.28	2067		2067	0.231			44	47	0.624	64	
B2	1	3.70	A	2				4250		982		982	0.00	4250		4250	0.231			44	47	0.623	66	
A3	2	3.30	B	2	20			4170			400	400	1.00	3879		3879	0.103			20	23	0.574	35	
C1	2,3	3.30	C,D	1	15		N	1945	390			390	1.00	1768		1768	0.221			42	44	0.642	55	
C2,C3	3	3.30	D	1	20			2085		40	110	150	0.73	1976		1976	0.076			14	18	0.540	28	
D1,D2,D3	4	3.30	E	1	15		N	1945	50	45	82	177	0.75	1810		1810	0.098	0.098		18	19	0.674	32	
D3	4	3.30	E	1	25			2085			193	193	1.00	1967		1967	0.098			19	19	0.677	35	
PED	2		G																28					
PED	3		H																24					

NOTE : 'O' - OPPOSING TRAFFIC N - NEAR SIDE LANE SG - STEADY GREEN FG - FLASHING GREEN PEDESTRIAN WALKING SPEED FOR SG(FG) = 1.2(0.9)m/s QUEUING LENGTH = AVERAGE QUEUE * 6m

J13 - Po Shek Wu Road / Po Wan Road

J13_2031_REF_PM

PROJECT NO:

Junction No. J13

DATE : 16/12/2024

FILENAME :

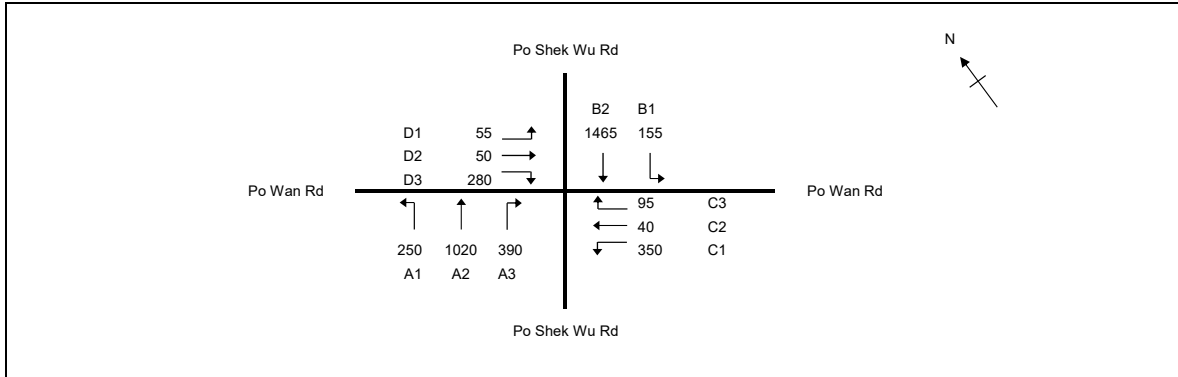

No. of stages per cycle	N = 4
No. of stage using for calculation	N = 2
Cycle time	C = 128 sec
Sum(y)	Y = 0.359
Loss time	L = 62 sec
Total Flow	= 4150 pcu
Co = (1.5*L+5)/(1-Y)	= 152.8 sec
Cm = L/(1-Y)	= 96.7 sec
Yult	= 0.435
R.C.ult = (Yult-Y)/Y*100%	= 21.3 %
Cp = 0.9*L/(0.9-Y)	= 103.1 sec
Ymax = 1-L/C	= 0.516
R.C.(C) = (0.9*Ymax-Y)/Y*100%	= 29 %

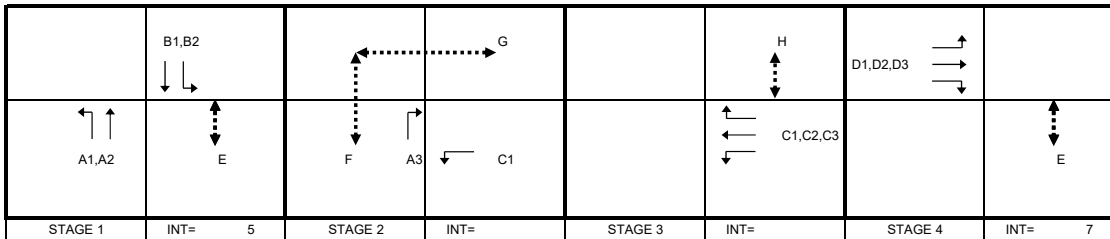

Pedestrian Phase	Width (m)	Green Time Required (s)			Green Time Provided (s)			Check
		SG	Delay	FG	SG	Delay	FG	
E	8	6	2	9	65	2	9	OK
F	8	7	6	7	15	6	7	OK
G	12	10	6	12	10	6	12	OK
H	7	6	10	8	6	10	8	OK

Movement	Stage	Lane Width m.	Phase	No. of lane	Radius m.	O	N	Straight-Ahead Sat. Flow	Flow			Total Flow pcu/h	Proportion of Turning Vehicles	Sat. Flow pcu/h	Uphill Gradient %	Short lane Effect pcu/h	Revised Sat. Flow pcu/h	y	Greater y	L sec	g (required) sec	g (input) sec	Degree of Saturation X	Queuing Length m.
									Left pcu/h	Straight pcu/h	Right pcu/h													
A1	1	3.30	A	1	15		N	1945	250			250	1.00	1768			1768	0.141	0.257	10	26	47	0.383	34
A1,A2	1	3.30	A	1	20			2085	0	510		510	0.00	2085			2085	0.245			45	47	0.663	69
A2	1	3.30	A	1				2085		510		510	0.00	2085			2085	0.245			45	47	0.663	69
B1,B2	1	3.70	A	1	15			2125	155	375		530	0.29	2065			2065	0.257			47	47	0.696	71
B2	1	3.70	A	2				4250		1090		1090	0.00	4250			4250	0.256			47	47	0.695	73
A3	2	3.30	B	2	20			4170			390	390	1.00	3879			3879	0.101			18	23	0.560	34
C1	2,3	3.30	C,D	1	15		N	1945	350			350	1.00	1768			1768	0.198			36	44	0.576	49
C2,C3	3	3.30	D	1	20			2085		40	95	135	0.70	1980			1980	0.068			13	18	0.485	25
D1,D2,D3	4	3.30	E	1	15		N	1945	55	50	80	185	0.73	1813			1813	0.102	0.102		19	19	0.696	34
D3	4	3.30	E	1	25			2085			200	200	1.00	1967			1967	0.102			19	19	0.693	36
PED	2		G																	28				
PED	3		H																	24				

NOTE : 'O' - OPPOSING TRAFFIC N - NEAR SIDE LANE SG - STEADY GREEN FG - FLASHING GREEN PEDESTRIAN WALKING SPEED FOR SG(FG) = 1.2(0.9)m/s QUEUING LENGTH = AVERAGE QUEUE * 6m

J13 - Po Shek Wu Road / Po Wan Road

J13_2031_DES_AM

PROJECT NO:

Junction No. J13

DATE : 16/12/2024

FILENAME :

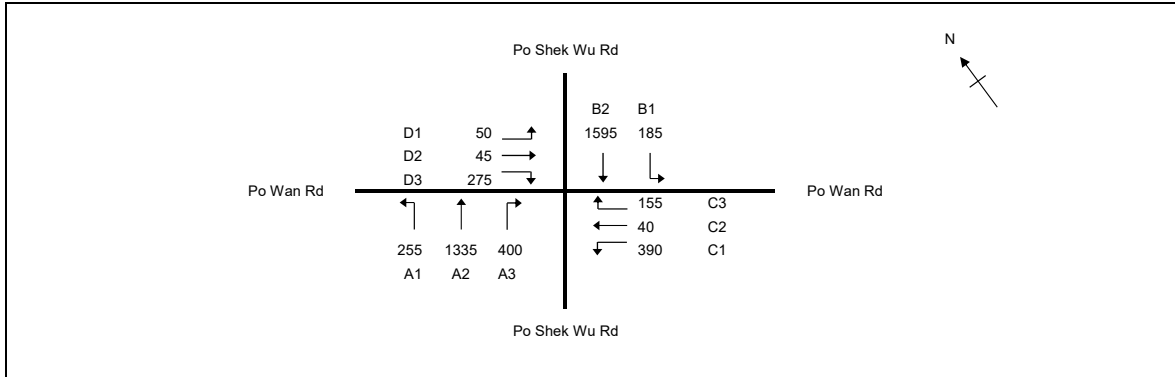

No. of stages per cycle	N = 4
No. of stage using for calculation	N = 2
Cycle time	C = 128 sec
Sum(y)	Y = 0.419
Loss time	L = 62 sec
Total Flow	= 4725 pcu
Co = (1.5*L+5)/(1-Y)	= 168.5 sec
Cm = L/(1-Y)	= 106.6 sec
Yult = (Yult-Y)/Y*100%	= 0.435
R.C.ult = (Yult-Y)/Y*100%	= 3.9 %
Cp = 0.9*L/(0.9-Y)	= 115.9 sec
Ymax = 1-L/C	= 0.516
R.C.(C) = (0.9*Ymax-Y)/Y*100%	= 10 %

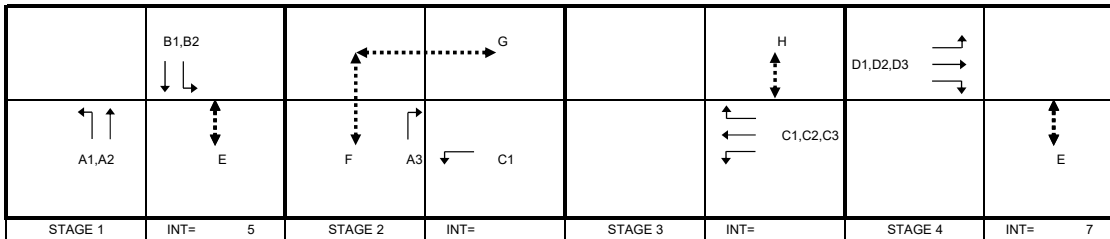

Pedestrian Phase	Width (m)	Green Time Required (s)			Green Time Provided (s)			Check
		SG	Delay	FG	SG	Delay	FG	
E	8	6	2	9	65	2	9	OK
F	8	7	6	7	15	6	7	OK
G	12	10	6	12	10	6	12	OK
H	7	6	10	8	6	10	8	OK

Movement	Stage	Lane Width m.	Phase	No. of lane	Radius m.	O	N	Straight-Ahead Sat. Flow	Flow			Total Flow pcu/h	Proportion of Turning Vehicles	Sat. Flow pcu/h	Uphill Gradient %	Short lane Effect pcu/h	Revised Sat. Flow pcu/h	y	Greater y	L sec	g (required) sec	g (input) sec	Degree of Saturation X	Queuing Length m.
									Left pcu/h	Straight pcu/h	Right pcu/h													
A1	1	3.30	A	1	15		N	1945	255			255	1.00	1768		1768	0.144	0.320	10	23	51	0.365	33	
A1,A2	1	3.30	A	1	20			2085	0	667		667	0.00	2085		2085	0.320			50	51	0.810	86	
A2	1	3.30	A	1				2085		668		668	0.00	2085		2085	0.320			51	51	0.812	86	
B1,B2	1	3.70	A	1	15			2125	185	398		583	0.32	2060		2060	0.283			45	51	0.717	75	
B2	1	3.70	A	2				4250		1197		1197	0.00	4250		4250	0.282			44	51	0.714	77	
A3	2	3.30	B	2	20			4170			400	400	1.00	3879		3879	0.103			16	23	0.574	35	
C1	2,3	3.30	C,D	1	15		N	1945	390		390	1.00	1768		1768	0.221			35	44	0.642	55		
C2,C3	3	3.30	D	1	20			2085		40	155	195	0.79	1968		1968	0.099			16	18	0.705	36	
D1,D2,D3	4	3.30	E	1	15		N	1945	50	45	82	177	0.75	1810		1810	0.098	0.098		15	15	0.809	33	
D3	4	3.30	E	1	25			2085			193	193	1.00	1967		1967	0.098			15	15	0.812	36	
PED	2		G																28					
PED	3		H																24					

NOTE : 'O' - OPPOSING TRAFFIC N - NEAR SIDE LANE SG - STEADY GREEN FG - FLASHING GREEN PEDESTRIAN WALKING SPEED FOR SG(FG) = 1.2(0.9)m/s QUEUING LENGTH = AVERAGE QUEUE * 6m

J13 - Po Shek Wu Road / Po Wan Road

J13_2031_DES_PM

PROJECT NO:

Junction No. J13

DATE : 16/12/2024

FILENAME :

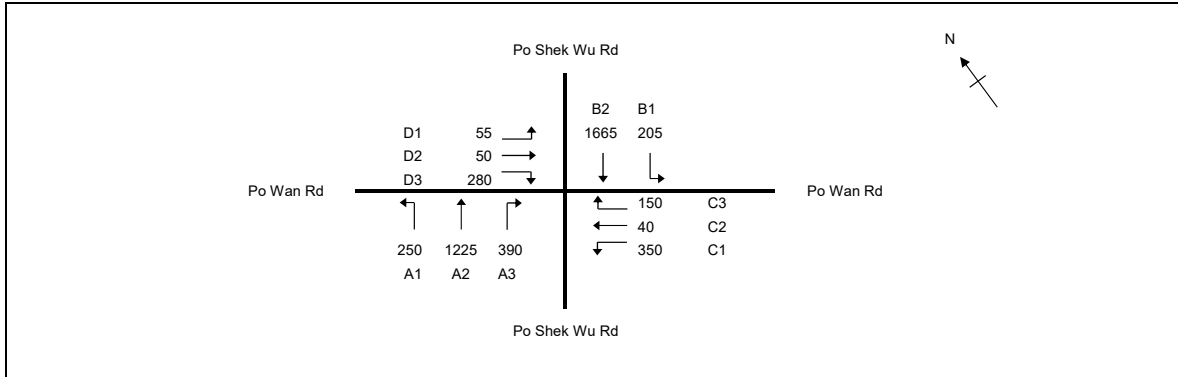

No. of stages per cycle	N = 4
No. of stage using for calculation	N = 2
Cycle time	C = 128 sec
Sum(y)	Y = 0.399
Loss time	L = 62 sec
Total Flow	= 4660 pcu
Co = (1.5*L+5)/(1-Y)	= 163.0 sec
Cm = L/(1-Y)	= 103.1 sec
Yult	= 0.435
R.C.ult = (Yult-Y)*Y*100%	= 9.1 %
Cp = 0.9*L/(0.9-Y)	= 111.3 sec
Ymax = 1-L/C	= 0.516
R.C.(C) = (0.9*Ymax-Y)*Y*100%	= 16 %

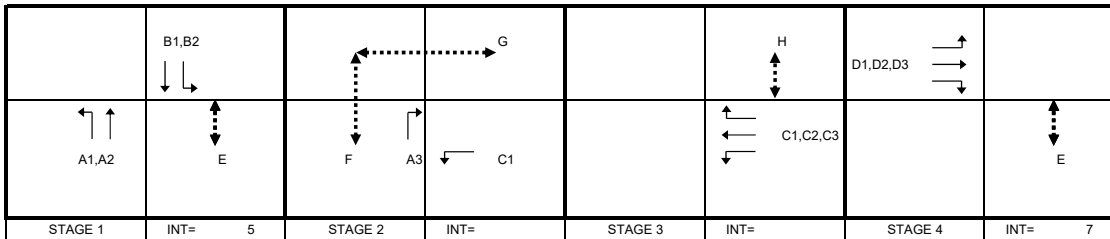

Pedestrian Phase	Width (m)	Green Time Required (s)			Green Time Provided (s)			Check
		SG	Delay	FG	SG	Delay	FG	
E	8	6	2	9	65	2	9	OK
F	8	7	6	7	15	6	7	OK
G	12	10	6	12	10	6	12	OK
H	7	6	10	8	6	10	8	OK

Movement	Stage	Lane Width m.	Phase	No. of lane	Radius m.	O	N	Straight-Ahead Sat. Flow	Flow			Total Flow pcu/h	Proportion of Turning Vehicles	Sat. Flow pcu/h	Uphill Gradient %	Short lane Effect pcu/h	Revised Sat. Flow pcu/h	y	Greater y	L sec	g (required) sec	g (input) sec	Degree of Saturation X	Queuing Length m.
									Left pcu/h	Straight pcu/h	Right pcu/h													
A1	1	3.30	A	1	15		N	1945	250			250	1.00	1768		1768	0.141	0.297	10	23	49	0.369	33	
A1,A2	1	3.30	A	1	20			2085	0	612		612	0.00	2085		2085	0.294			49	49	0.765	80	
A2	1	3.30	A	1				2085		613		613	0.00	2085		2085	0.294			49	49	0.766	81	
B1,B2	1	3.70	A	1	15			2125	205	405		610	0.34	2056		2056	0.297			49	49	0.773	80	
B2	1	3.70	A	2				4250		1260		1260	0.00	4250		4250	0.296			49	49	0.773	83	
A3	2	3.30	B	2	20			4170			390	390	1.00	3879		3879	0.101			17	23	0.560	34	
C1	2,3	3.30	C,D	1	15		N	1945	350			350	1.00	1768		1768	0.198			33	44	0.576	49	
C2,C3	3	3.30	D	1	20			2085		40	150	190	0.79	1968		1968	0.097			16	18	0.686	35	
D1,D2,D3	4	3.30	E	1	15		N	1945	55	50	80	185	0.73	1813		1813	0.102	0.102		17	17	0.773	34	
D3	4	3.30	E	1	25			2085			200	200	1.00	1967		1967	0.102			17	17	0.770	37	
PED	2		G																28					
PED	3		H																24					

NOTE : 'O' - OPPOSING TRAFFIC N - NEAR SIDE LANE SG - STEADY GREEN FG - FLASHING GREEN PEDESTRIAN WALKING SPEED FOR SG(FG) = 1.2(0.9)m/s QUEUING LENGTH = AVERAGE QUEUE * 6m

J14 - Po Shek Wu Road / Choi Yuen Road

J14_2023_EXT_AM

PROJECT NO: 287082

Junction No. J14

DATE : 16/12/2024

FILENAME :

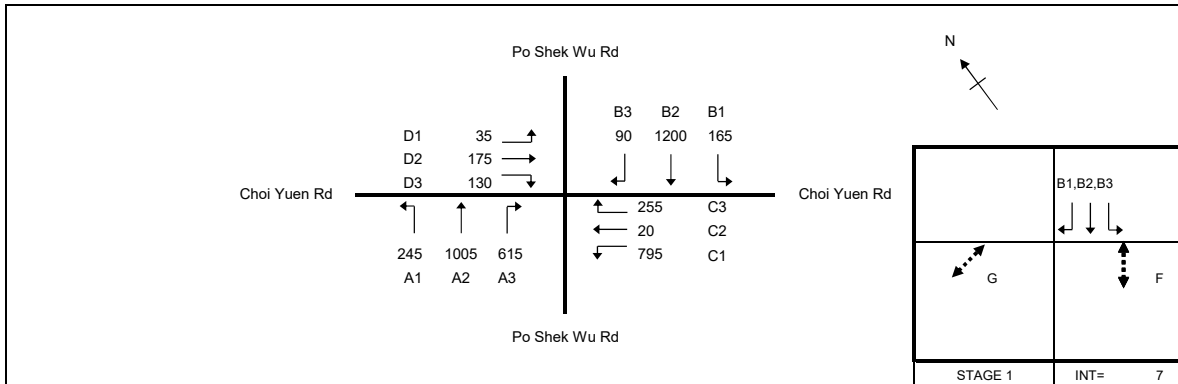

No. of stages per cycle	N = 5
No. of stage using for calculation	N = 4
Cycle time	C = 135 sec
Sum(y)	Y = 0.546
Loss time	L = 24 sec
Total Flow	= 4730 pcu
Co	= (1.5*L+5)/(1-Y) = 90.3 sec
Cm	= L/(1-Y) = 52.9 sec
Yult	= 0.720
R.C.ult	= (Yult-Y)/Y*100% = 31.9 %
Cp	= 0.9*L/(0.9-Y) = 61.0 sec
Ymax	= 1-L/C = 0.822
R.C.(C)	= (0.9*Ymax-Y)/Y*100% = 36 %

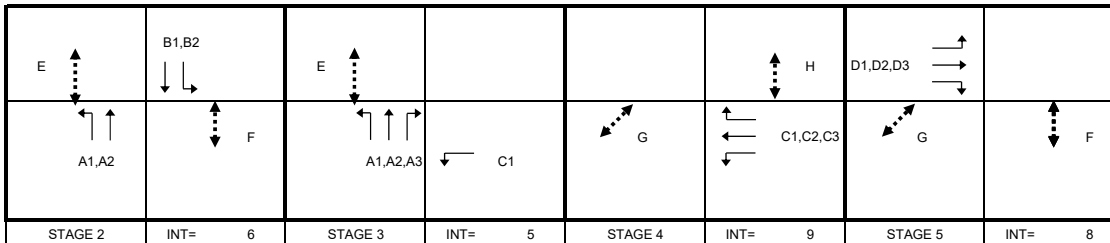

Pedestrian Phase	Width (m)	Green Time Required (s)			Green Time Provided (s)			Check
		SG	Delay	FG	SG	Delay	FG	
E	15	13	8	15	41	8	15	OK
F	14	6	1	16	45	1	16	OK
G	5.5	6	1	6	64	1	6	OK
H	11	6	10	12	16	10	12	OK

Move-ment	Stage	Lane Width m.	Phase	No. of lane	Radius m.	O	N	Straight-Ahead Sat. Flow	Flow			Total Flow pcu/h	Proportion of Turning Vehicles	Sat. Flow pcu/h	Uphill Gradient %	Short lane Effect pcu/h	Revised Sat. Flow pcu/h	y	Greater y	L sec	g (required) sec	g (input) sec	Degree of Saturation X	Queuing Length m.
									Left pcu/h	Straight pcu/h	Right pcu/h													
A1,A2	2,3	3.50	D	1	15		N	1965	245	417		662	0.37	1895		474	2369	0.279		57	60	0.627	83	
A2	2,3	3.50	D	1				2105		588		588	0.00	2105			2105	0.279		57	60	0.626	73	
A3	3	3.50	D	2	20			4210			615	615	1.00	3916			3916	0.157	0.157	32	32	0.664	53	
C1	3,4	3.30	F,G	2	15		N	4030	795			795	1.00	3664			3664	0.217		44	65	0.453	47	
C2,C3	4	3.30	G	1	20			2085		20	255	275	0.93	1949			1949	0.141	0.141	29	29	0.664	49	
D1,D2	5	3.30	H	1	15		N	1945	35	74		109	0.32	1884			1884	0.058	0.058	12	12	0.664	22	
D2,D3	5	3.30	H	1	25			2085		101	18	119	0.15	2066			2066	0.058		12	12	0.661	24	
D3	5	3.30	H	1	20			2085			112	112	1.00	1940			1940	0.058		12	12	0.663	23	
B1	1,2	3.50	B	1	15		N	1965	165			165	1.00	1786			1786	0.092		19	39	0.323	27	
B2	1,2	3.50	B	3				6315		1200		1200	0.00	6315			6315	0.190	0.190	39	39	0.664	64	
B3	1	3.50	A	1	20			2105			90	90	1.00	1958			1958	0.046		9	9	0.664	19	

NOTE : 'O' - OPPOSING TRAFFIC

N - NEAR SIDE LANE

SG - STEADY GREEN

FG - FLASHING GREEN

PEDESTRIAN WALKING SPEED FOR SG(FG) = 1.2(0.9)m/s

QUEUING LENGTH = AVERAGE QUEUE * 6m

J14 - Po Shek Wu Road / Choi Yuen Road

J14_2023_EXT_PM

PROJECT NO: 287082

Junction No. J14

DATE : 16/12/2024

FILENAME :

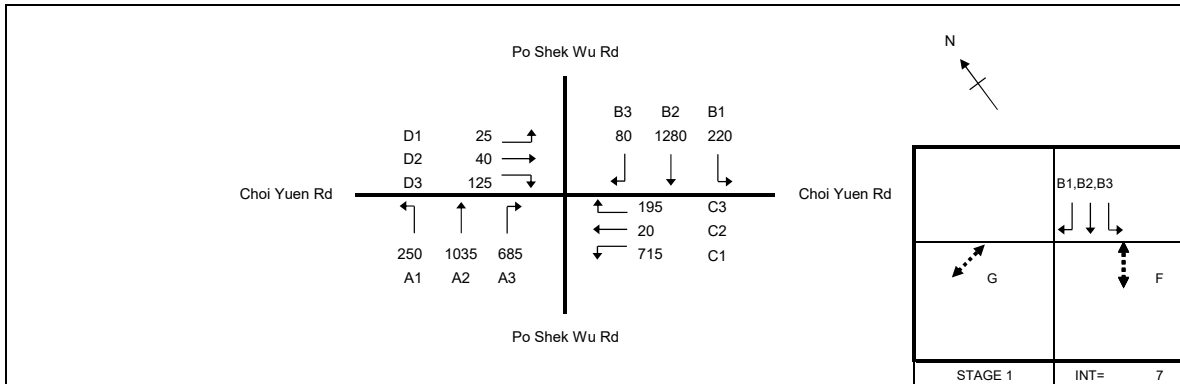

No. of stages per cycle	N = 5
No. of stage using for calculation	N = 4
Cycle time	C = 135 sec
Sum(y)	Y = 0.521
Loss time	L = 24 sec
Total Flow	= 4670 pcu
Co	= (1.5*L+5)/(1-Y) = 85.5 sec
Cm	= L/(1-Y) = 50.1 sec
Yult	= 0.720
R.C.ult	= (Yult-Y)/Y*100% = 38.3 %
Cp	= 0.9*L/(0.9-Y) = 57.0 sec
Ymax	= 1-L/C = 0.822
R.C.(C)	= (0.9*Ymax-Y)/Y*100% = 42 %

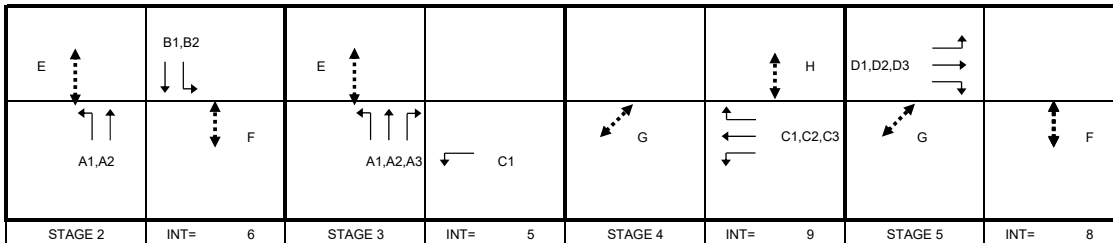

Pedestrian Phase	Width (m)	Green Time Required (s)			Green Time Provided (s)			Check
		SG	Delay	FG	SG	Delay	FG	
E	15	13	8	15	52	8	15	OK
F	14	6	1	16	45	1	16	OK
G	5.5	6	1	6	53	1	6	OK
H	11	6	10	12	10	10	12	OK

Move-ment	Stage	Lane Width m.	Phase	No. of lane	Radius m.	O	N	Straight-Ahead Sat. Flow	Flow			Total Flow pcu/h	Proportion of Turning Vehicles	Sat. Flow pcu/h	Uphill Gradient %	Short lane Effect pcu/h	Revised Sat. Flow pcu/h	y	Greater y	L sec	g (required) sec	g (input) sec	Degree of Saturation X	Queuing Length m.
									Left pcu/h	Straight pcu/h	Right pcu/h													
A1,A2	2,3	3.50	D	1	15		N	1965	250	430		680	0.37	1895		474	2369	0.287		24	61	71	0.547	73
A2	2,3	3.50	D	1				2105		605		605	0.00	2105			2105	0.287			61	71	0.548	65
A3	3	3.50	D	2	20			4210			685	685	1.00	3916			3916	0.175	0.175		37	37	0.633	56
C1	3,4	3.30	F,G	2	15		N	4030	715			715	1.00	3664			3664	0.195			42	65	0.407	42
C2,C3	4	3.30	G	1	20			2085		20	195	215	0.91	1952			1952	0.110	0.110		23	23	0.633	40
D1,D2	5	3.30	H	1	15		N	1945	25	36		61	0.41	1868			1868	0.033	0.033		7	7	0.627	13
D2,D3	5	3.30	H	1	25			2085		4	61	65	0.94	1974			1974	0.033			7	7	0.632	14
D3	5	3.30	H	1	20			2085			64	64	1.00	1940			1940	0.033			7	7	0.633	14
B1	1,2	3.50	B	1	15		N	1965	220			220	1.00	1786			1786	0.123			26	43	0.385	34
B2	1,2	3.50	B	3				6315		1280		1280	0.00	6315			6315	0.203	0.203		43	43	0.633	65
B3	1	3.50	A	1	20			2105			80	80	1.00	1958			1958	0.041			9	9	0.633	17

NOTE : 'O' - OPPOSING TRAFFIC

N - NEAR SIDE LANE

SG - STEADY GREEN

FG - FLASHING GREEN

PEDESTRIAN WALKING SPEED FOR SG(FG) = 1.2(0.9)m/s

QUEUING LENGTH = AVERAGE QUEUE * 6m

J14 - Po Shek Wu Road / Choi Yuen Road

J14_2031_REF_AM

PROJECT NO: 287082

Junction No. J14

DATE : 16/12/2024

FILENAME :

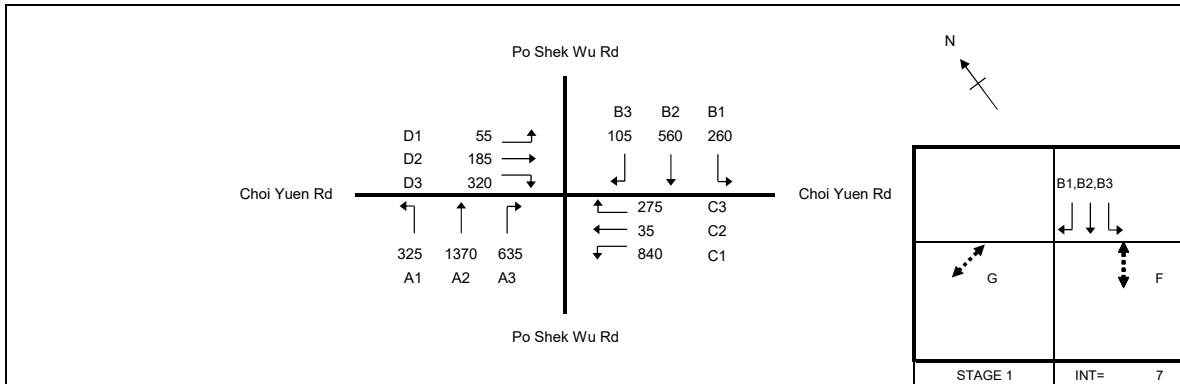

No. of stages per cycle	N = 5
No. of stage using for calculation	N = 4
Cycle time	C = 135 sec
Sum(y)	Y = 0.556
Loss time	L = 24 sec
Total Flow	= 4965 pcu
Co	= (1.5*L+5)/(1-Y) = 92.4 sec
Cm	= L/(1-Y) = 54.1 sec
Yult	= 0.720
R.C.ult	= (Yult-Y)/Y*100% = 29.4 %
Cp	= 0.9*L/(0.9-Y) = 62.9 sec
Ymax	= 1-L/C = 0.822
R.C.(C)	= (0.9*Ymax-Y)/Y*100% = 33 %

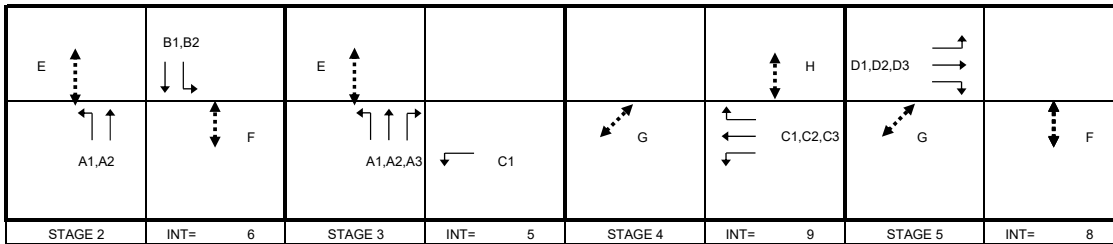

Pedestrian Phase	Width (m)	Green Time Required (s)			Green Time Provided (s)			Check
		SG	Delay	FG	SG	Delay	FG	
E	15	13	8	15	29	8	15	OK
F	14	6	1	16	42	1	16	OK
G	5.5	6	1	6	76	1	6	OK
H	11	6	10	12	19	10	12	OK

Move-ment	Stage	Lane Width m.	Phase	No. of lane	Radius m.	O	N	Straight-Ahead Sat. Flow	Flow			Total Flow pcu/h	Proportion of Turning Vehicles	Sat. Flow pcu/h	Uphill Gradient %	Short lane Effect pcu/h	Revised Sat. Flow pcu/h	y	Greater y	L sec	g (required) sec	g (input) sec	Degree of Saturation X	Queuing Length m.
									Left pcu/h	Straight pcu/h	Right pcu/h													
A1,A2	2,3	3.60	D	1	15		N	1975	325	325		650	0.50	1881		752	2633	0.247		49	48	0.689	94	
A2	2,3	3.60	D	2				4230		1045		1045	0.00	4230			4230	0.247		49	48	0.689	75	
A3	3	3.60	D	2	20			4230			635	635	1.00	3935			3935	0.161	0.161	32	32	0.677	54	
C1	3,4	3.30	F,G	2	15		N	4030	840			840	1.00	3664			3664	0.229		46	68	0.456	47	
C2,C3	4	3.30	G	1	20			2085		35	275	310	0.89	1955			1955	0.159	0.159	32	32	0.677	53	
D1,D2	5	3.30	H	1	15		N	1945	55	127		182	0.30	1888			1888	0.096	0.096	19	19	0.677	35	
D2,D3	5	3.30	H	1	25			2085		58	134	192	0.70	2001			2001	0.096		19	19	0.673	37	
D3	5	3.30	H	1	20			2085			186	186	1.00	1940			1940	0.096		19	19	0.673	36	
B1	1,2	3.40	B	1	10		N	1955	238			238	1.00	1700			1700	0.140	0.140	28	28	0.677	42	
B1,B2	1,2	3.40	B	1	10			2095	22	267		289	0.08	2071			2071	0.140		28	28	0.675	52	
B2	1,2	3.40	B	1				2095		293		293	0.00	2095			2095	0.140		28	28	0.676	52	
B3	1	3.40	A	1	20			2095			105	105	1.00	1949			1949	0.054		11	11	0.677	22	

NOTE : 'O' - OPPOSING TRAFFIC

N - NEAR SIDE LANE

SG - STEADY GREEN

FG - FLASHING GREEN

PEDESTRIAN WALKING SPEED FOR SG(FG) = 1.2(0.9)m/s

QUEUING LENGTH = AVERAGE QUEUE * 6m

J14 - Po Shek Wu Road / Choi Yuen Road

J14_2031_REF_PM

PROJECT NO: 287082

Junction No. J14

DATE : 16/12/2024

FILENAME :

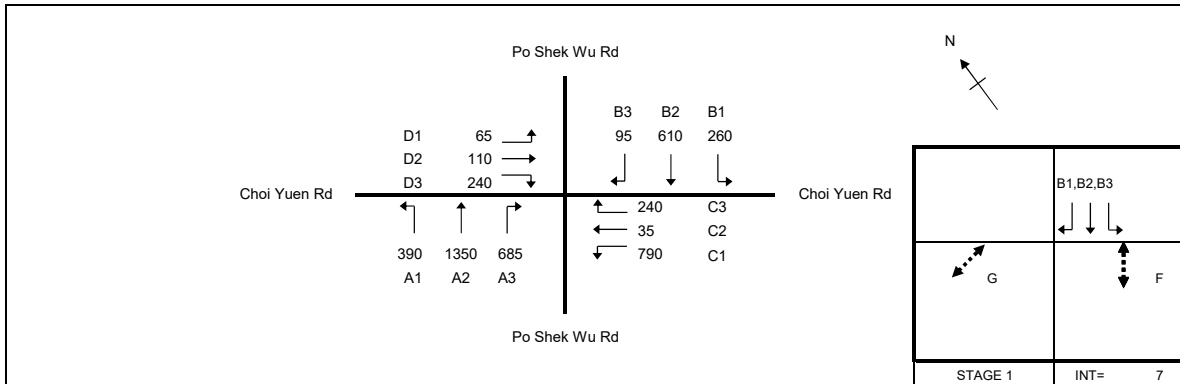

No. of stages per cycle	N = 5
No. of stage using for calculation	N = 4
Cycle time	C = 135 sec
Sum(y)	Y = 0.534
Loss time	L = 24 sec
Total Flow	= 4870 pcu
Co	= (1.5*L+5)/(1-Y) = 88.1 sec
Cm	= L/(1-Y) = 51.6 sec
Yult	= 0.720
R.C.ult	= (Yult-Y)/Y*100% = 34.7 %
Cp	= 0.9*L/(0.9-Y) = 59.1 sec
Ymax	= 1-L/C = 0.822
R.C.(C)	= (0.9*Ymax-Y)/Y*100% = 38 %

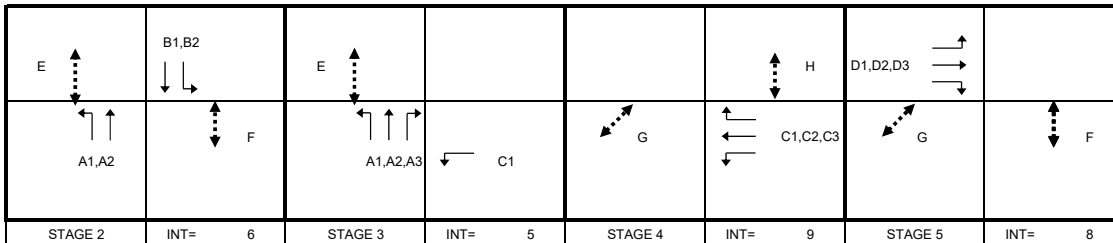

Pedestrian Phase	Width (m)	Green Time Required (s)			Green Time Provided (s)			Check
		SG	Delay	FG	SG	Delay	FG	
E	15	13	8	15	37	8	15	OK
F	14	6	1	16	41	1	16	OK
G	5.5	6	1	6	68	1	6	OK
H	11	6	10	12	16	10	12	OK

Move-ment	Stage	Lane Width m.	Phase	No. of lane	Radius m.	O	N	Straight-Ahead Sat. Flow	Flow			Total Flow pcu/h	Proportion of Turning Vehicles	Sat. Flow pcu/h	Uphill Gradient %	Short lane Effect pcu/h	Revised Sat. Flow pcu/h	y	Greater y	L sec	g (required) sec	g (input) sec	Degree of Saturation X	Queuing Length m.
									Left pcu/h	Straight pcu/h	Right pcu/h													
A1,A2	2,3	3.60	D	1	15		N	1975	390	274		664	0.59	1865		746	2612	0.254		24	53	56	0.615	88
A2	2,3	3.60	D	2				4230		1076		1076	0.00	4230			4230	0.254			53	56	0.615	71
A3	3	3.60	D	2	20			4230			685	685	1.00	3935			3935	0.174	0.174		36	36	0.650	56
C1	3,4	3.30	F,G	2	15		N	4030	790			790	1.00	3664			3664	0.216			45	69	0.420	43
C2,C3	4	3.30	G	1	20			2085		35	240	275	0.87	1957			1957	0.141	0.141		29	29	0.650	48
D1,D2	5	3.30	H	1	15		N	1945	65	68		133	0.49	1854			1854	0.072	0.072		15	15	0.650	27
D2,D3	5	3.30	H	1	25			2085		42	101	143	0.71	2000			2000	0.071			15	15	0.648	29
D3	5	3.30	H	1	20			2085			139	139	1.00	1940			1940	0.072			15	15	0.650	28
B1	1,2	3.40	B	1	10		N	1955	251			251	1.00	1700			1700	0.148	0.148		31	31	0.648	44
B1,B2	1,2	3.40	B	1	10			2095	9	300		309	0.03	2086			2086	0.148			31	31	0.650	54
B2	1,2	3.40	B	1				2095		310		310	0.00	2095			2095	0.148			31	31	0.649	54
B3	1	3.40	A	1	20			2095			95	95	1.00	1949			1949	0.049			10	10	0.650	20

NOTE : 'O' - OPPOSING TRAFFIC

N - NEAR SIDE LANE

SG - STEADY GREEN

FG - FLASHING GREEN

PEDESTRIAN WALKING SPEED FOR SG(FG) = 1.2(0.9)m/s

QUEUING LENGTH = AVERAGE QUEUE * 6m

J14 - Po Shek Wu Road / Choi Yuen Road

J14_2031_DES_AM

PROJECT NO: 287082

Junction No. J14

DATE : 16/12/2024

FILENAME :

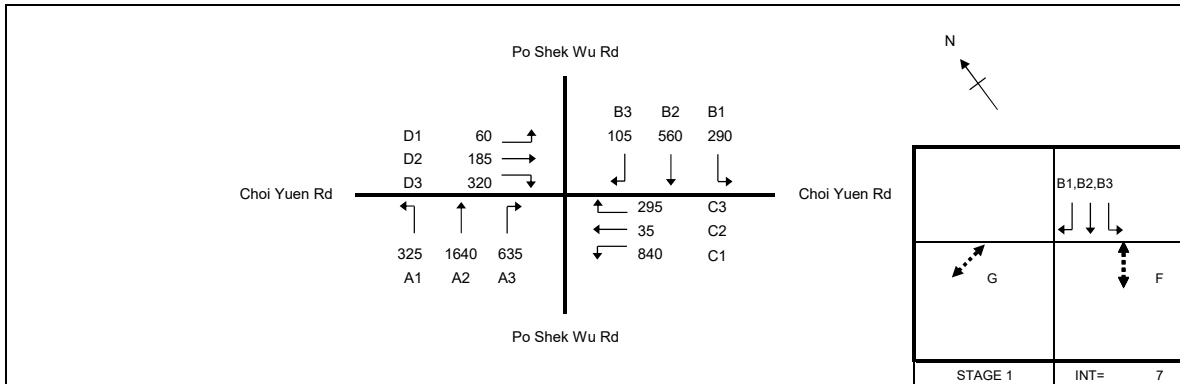

No. of stages per cycle	N = 5
No. of stage using for calculation	N = 4
Cycle time	C = 135 sec
Sum(y)	Y = 0.606
Loss time	L = 25 sec
Total Flow	= 5290 pcu
Co	= (1.5*L+5)/(1-Y) = 107.7 sec
Cm	= L/(1-Y) = 63.4 sec
Yult	= 0.713
R.C.ult	= (Yult-Y)/Y*100% = 17.7 %
Cp	= 0.9*L/(0.9-Y) = 76.4 sec
Ymax	= 1-L/C = 0.815
R.C.(C)	= (0.9*Ymax-Y)/Y*100% = 21 %

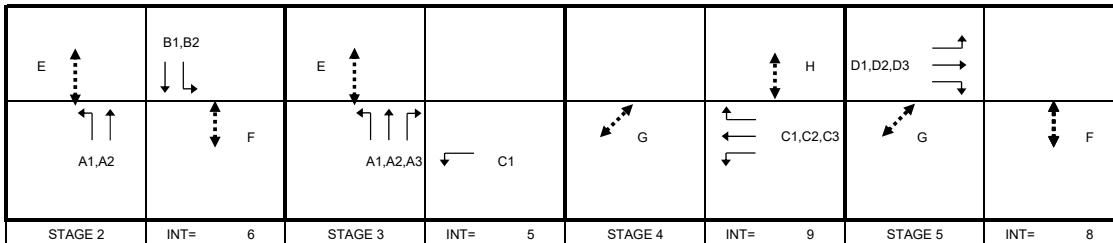

Pedestrian Phase	Width (m)	Green Time Required (s)			Green Time Provided (s)			Check
		SG	Delay	FG	SG	Delay	FG	
E	15	13	8	15	35	8	15	OK
F	14	6	1	16	49	1	16	OK
G	5.5	6	1	6	70	1	6	OK
H	11	6	10	12	14	10	12	OK

Move-ment	Stage	Lane Width m.	Phase	No. of lane	Radius m.	O	N	Straight-Ahead Sat. Flow	Flow			Total Flow pcu/h	Proportion of Turning Vehicles	Sat. Flow pcu/h	Uphill Gradient %	Short lane Effect pcu/h	Revised Sat. Flow pcu/h	y	Greater y	L sec	g (required) sec	g (input) sec	Degree of Saturation X	Queuing Length m.
									Left pcu/h	Straight pcu/h	Right pcu/h													
A1,A2	2,3	3.60	D	1	15		N	1975	325	432		757	0.43	1894		757	2651	0.286	0.286	25	52	52	0.743	105
A2	2,3	3.60	D	2				4230		1208		1208	0.00	4230			4230	0.286			52	52	0.743	84
A3	3	3.60	D	2	20			4230			635	635	1.00	3935			3935	0.161			29	29	0.743	56
C1	3,4	3.30	F,G	2	15		N	4030	840			840	1.00	3664			3664	0.229			42	62	0.499	51
C2,C3	4	3.30	G	1	20			2085		35	295	330	0.89	1954			1954	0.169	0.169		31	31	0.743	57
D1,D2	5	3.30	H	1	15		N	1945	60	123		183	0.33	1883			1883	0.097	0.097		18	18	0.743	36
D2,D3	5	3.30	H	1	25			2085		62	132	194	0.68	2003			2003	0.097			18	18	0.741	38
D3	5	3.30	H	1	20			2085			188	188	1.00	1940			1940	0.097			18	18	0.741	37
B1	1,2	3.40	B	1	10		N	1955	244			244	1.00	1700			1700	0.144			26	33	0.581	41
B1,B2	1,2	3.40	B	1	10			2095	46	253		299	0.15	2048			2048	0.146			27	33	0.591	51
B2	1,2	3.40	B	1				2095		307		307	0.00	2095			2095	0.147			27	33	0.593	52
B3	1	3.40	A	1	20			2095			105	105	1.00	1949			1949	0.054	0.054		10	10	0.743	22

NOTE : 'O' - OPPOSING TRAFFIC

N - NEAR SIDE LANE

SG - STEADY GREEN

FG - FLASHING GREEN

PEDESTRIAN WALKING SPEED FOR SG(FG) = 1.2(0.9)m/s

QUEUING LENGTH = AVERAGE QUEUE * 6m

J14 - Po Shek Wu Road / Choi Yuen Road

J14_2031_DES_PM

PROJECT NO: 287082

Junction No. J14

DATE : 16/12/2024

FILENAME :

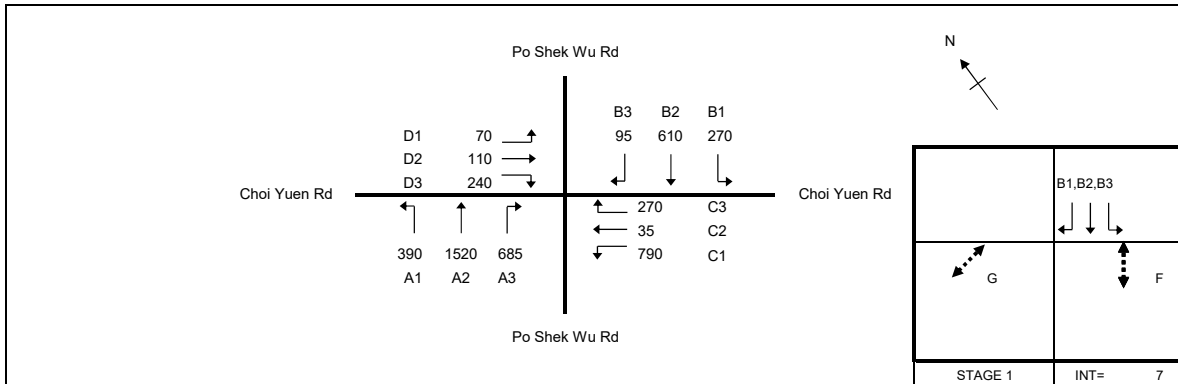

No. of stages per cycle	N = 5
No. of stage using for calculation	N = 4
Cycle time	C = 135 sec
Sum(y)	Y = 0.556
Loss time	L = 25 sec
Total Flow	= 5085 pcu
Co	= (1.5*L+5)/(1-Y) = 95.8 sec
Cm	= L/(1-Y) = 56.3 sec
Yult	= 0.713
R.C.ult	= (Yult-Y)/Y*100% = 28.1 %
Cp	= 0.9*L/(0.9-Y) = 65.4 sec
Ymax	= 1-L/C = 0.815
R.C.(C)	= (0.9*Ymax-Y)/Y*100% = 31 %

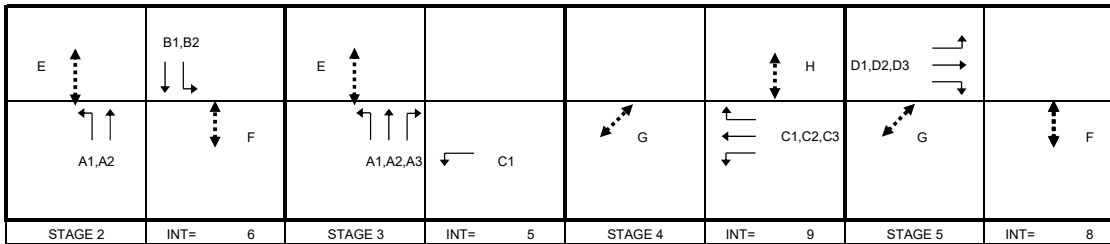

Pedestrian Phase	Width (m)	Green Time Required (s)			Green Time Provided (s)			Check
		SG	Delay	FG	SG	Delay	FG	
E	15	13	8	15	38	8	15	OK
F	14	6	1	16	44	1	16	OK
G	5.5	6	1	6	67	1	6	OK
H	11	6	10	12	14	10	12	OK

Move-ment	Stage	Lane Width m.	Phase	No. of lane	Radius m.	O	N	Straight-Ahead Sat. Flow	Flow			Total Flow pcu/h	Proportion of Turning Vehicles	Sat. Flow pcu/h	Uphill Gradient %	Short lane Effect pcu/h	Revised Sat. Flow pcu/h	y	Greater y	L sec	g (required) sec	g (input) sec	Degree of Saturation X	Queuing Length m.
									Left pcu/h	Straight pcu/h	Right pcu/h													
A1,A2	2,3	3.60	D	1	15		N	1975	390	341		731	0.53	1875		750	2625	0.278	0.279	25	55	55	0.682	97
A2	2,3	3.60	D	2				4230		1179		1179	0.00	4230			4230	0.279			55	55	0.683	78
A3	3	3.60	D	2	20			4230			685	685	1.00	3935			3935	0.174			34	34	0.683	57
C1	3,4	3.30	F,G	2	15		N	4030	790			790	1.00	3664			3664	0.216			43	67	0.433	45
C2,C3	4	3.30	G	1	20			2085		35	270	305	0.89	1955			1955	0.156	0.156		31	31	0.683	53
D1,D2	5	3.30	H	1	15		N	1945	70	64		134	0.52	1848			1848	0.072	0.073		14	14	0.681	27
D2,D3	5	3.30	H	1	25			2085		46	99	145	0.68	2003			2003	0.072			14	14	0.680	29
D3	5	3.30	H	1	20			2085			141	141	1.00	1940			1940	0.073			14	14	0.683	28
B1	1,2	3.40	B	1	10		N	1955	255			255	1.00	1700			1700	0.150			30	31	0.646	44
B1,B2	1,2	3.40	B	1	10			2095	15	296		311	0.05	2080			2080	0.150			30	31	0.644	54
B2	1,2	3.40	B	1				2095		314		314	0.00	2095			2095	0.150			30	31	0.646	54
B3	1	3.40	A	1	20			2095			95	95	1.00	1949			1949	0.049	0.049		10	10	0.683	20

NOTE : 'O' - OPPOSING TRAFFIC N - NEAR SIDE LANE SG - STEADY GREEN FG - FLASHING GREEN PEDESTRIAN WALKING SPEED FOR SG(FG) = 1.2(0.9)m/s QUEUING LENGTH = AVERAGE QUEUE * 6m

J15 - Ling Ma Hang Rd / Access Rd

J15_2031_DES_AM

PROJECT NO:

Junction No.

J15

DATE :

16-Dec-24

FILENAME :

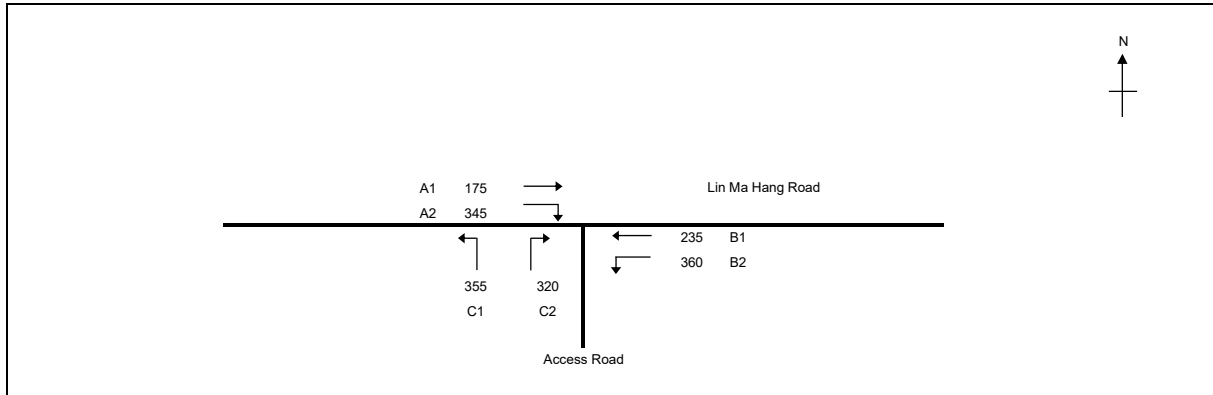

No. of stages per cycle	N =	3
No. of stage using for calculation	N =	3
Cycle time	C =	90 sec
Sum(y)	Y =	0.585
Loss time	L =	15 sec
Total Flow	=	1790 pcu
Co	= (1.5*L+5)/(1-Y)	= 66.2 sec
Cm	= L/(1-Y)	= 36.1 sec
Yult	=	0.788
R.C.ult	= (Yult-Y)/Y*100%	= 34.7 %
Cp	= 0.9*L/(0.9-Y)	= 42.8 sec
Ymax	= 1-L/C	= 0.833
R.C.(C)	= (0.9*Ymax-Y)/Y*100%	= 28 %

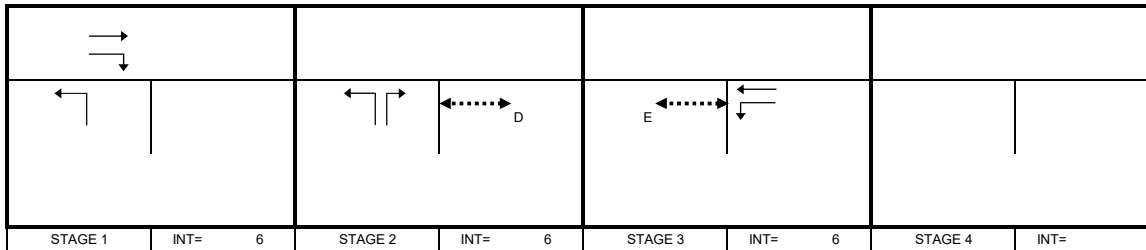

STAGE 1	INT=	6	STAGE 2	INT=	6	STAGE 3	INT=	6	STAGE 4	INT=	
---------	------	---	---------	------	---	---------	------	---	---------	------	--

Pedestrian Phase	Width (m)	Green Time Required (s)			Green Time Provided (s)			Check
		SG	Delay	FG	SG	Delay	FG	
D	8.5	6	6	9	11	6	9	OK
E	7.5	6	2	8	24	2	8	OK

Move-ment	Stage	Lane Width m.	Phase	No. of lane	Radius m.	O	N	Straight-Ahead Sat. Flow	Flow			Total Flow pcu/h	Proportion of Turning Vehicles	Sat. Flow pcu/h	Uphill Gradient %	Short lane Effect pcu/h	Revised Sat. Flow pcu/h	y	Greater y	L sec	g (required) sec	g (input) sec	Degree of Saturation X	Queuing Length m.
									Left pcu/h	Straight pcu/h	Right pcu/h													
A1,A2	1	3.50	A	1	15			2105		175	345	520	0.66	1974	790	2764	0.188	0.188	15	24	24	0.702	57	
C1	1,2	3.50	C	1	10		N	1965	355		320	355	1.00	1709		1709	0.208			27	51	0.370	23	
C2	2	3.50	C	1	15			2105			320	320	1.00	1914		1914	0.167	0.167		21	21	0.702	37	
B1,B2	3	3.50	B	1	15		N	1965	360	235		595	0.61	1853	741	2594	0.229	0.229		29	29	0.702	60	

NOTE : 'O' - OPPOSING TRAFFIC 'N' - NEAR SIDE LANE SG - STEADY GREEN FG - FLASHING GREEN PEDESTRIAN WALKING SPEED FOR SG(FG) = 1.2(0.9)m/s QUEUING LENGTH = AVERAGE QUEUE * 6m

PROJECT NO: J15
 DATE: 16-Dec-24
 Junction No. J15
 FILENAME:

J15 - Ling Ma Hang Rd / Access Rd

J15_2031_DES_PM

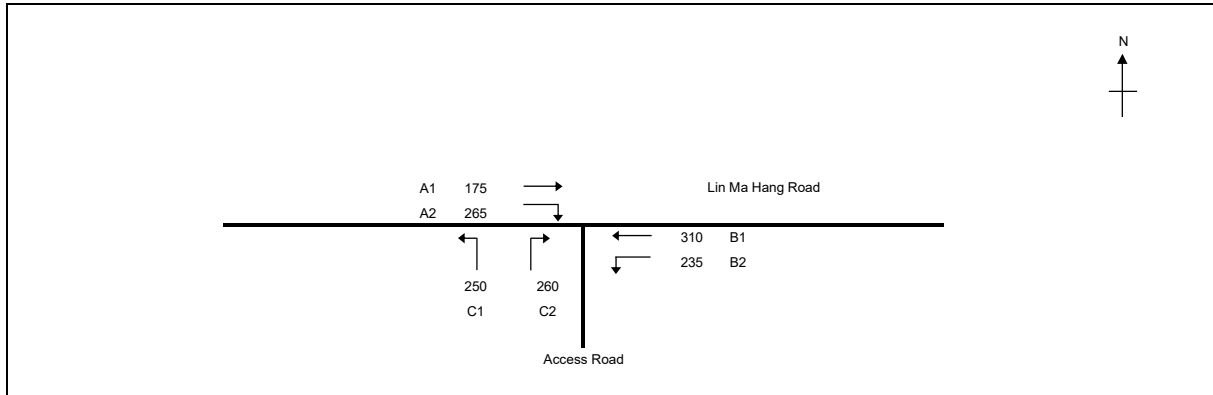

No. of stages per cycle	N =	3
No. of stage using for calculation	N =	3
Cycle time	C =	90 sec
Sum(y)	Y =	0.501
Loss time	L =	15 sec
Total Flow	=	1495 pcu
Co	= (1.5*L+5)/(1-Y)	= 55.1 sec
Cm	= L/(1-Y)	= 30.0 sec
Yult	=	0.788
R.C.ult	= (Yult-Y)/Y*100%	= 57.2 %
Cp	= 0.9*L/(0.9-Y)	= 33.8 sec
Ymax	= 1-L/C	= 0.833
R.C.(C)	= (0.9*Ymax-Y)/Y*100%	= 49 %

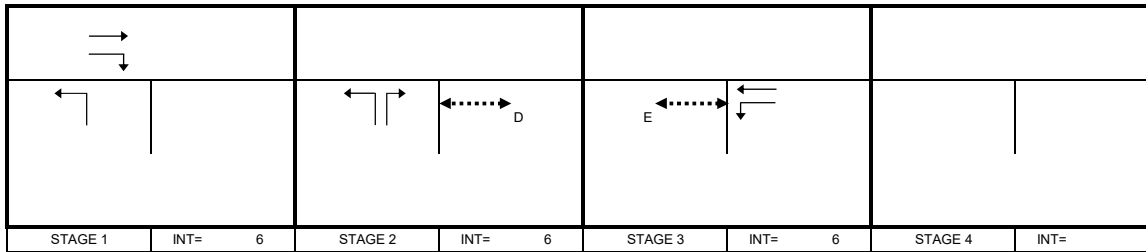

STAGE 1 INT= 6 STAGE 2 INT= 6 STAGE 3 INT= 6 STAGE 4 INT=

Pedestrian Phase	Width (m)	Green Time Required (s)			Green Time Provided (s)			Check
		SG	Delay	FG	SG	Delay	FG	
D	8.5	6	6	9	10	6	9	OK
E	7.5	6	2	8	26	2	8	OK

Move-ment	Stage	Lane Width m.	Phase	No. of lane	Radius m.	O	N	Straight-Ahead Sat. Flow	Flow			Total Flow pcu/h	Proportion of Turning Vehicles	Sat. Flow pcu/h	Uphill Gradient %	Short lane Effect pcu/h	Revised Sat. Flow pcu/h	y	Greater y	L sec	g (required) sec	g (input) sec	Degree of Saturation X	Queuing Length m.
									Left pcu/h	Straight pcu/h	Right pcu/h													
A1,A2	1	3.50	A	1	15			2105		175	265	440	0.60	1985	794	2780	0.158	0.158	15	24	24	0.601	49	
C1	1,2	3.50	C	1	10		N	1965	250		260	250	1.00	1709		1709	0.146			22	49	0.268	17	
C2	2	3.50	C	1	15			2105		260		260	1.00	1914		1914	0.136	0.136		20	20	0.601	30	
B1,B2	3	3.50	B	1	15		N	1965	235	310		545	0.43	1884	754	2637	0.207	0.207		31	31	0.601	54	

NOTE : 'O' - OPPOSING TRAFFIC N - NEAR SIDE LANE SG - STEADY GREEN FG - FLASHING GREEN PEDESTRIAN WALKING SPEED FOR SG(FG) = 1.2(0.9)m/s QUEUING LENGTH = AVERAGE QUEUE * 6m

J16 - Sha Tau Kok Road / Fanling Bypass

J16_2031_REF_AM

DATE 16/12/2024

PROJECT NO. 287082

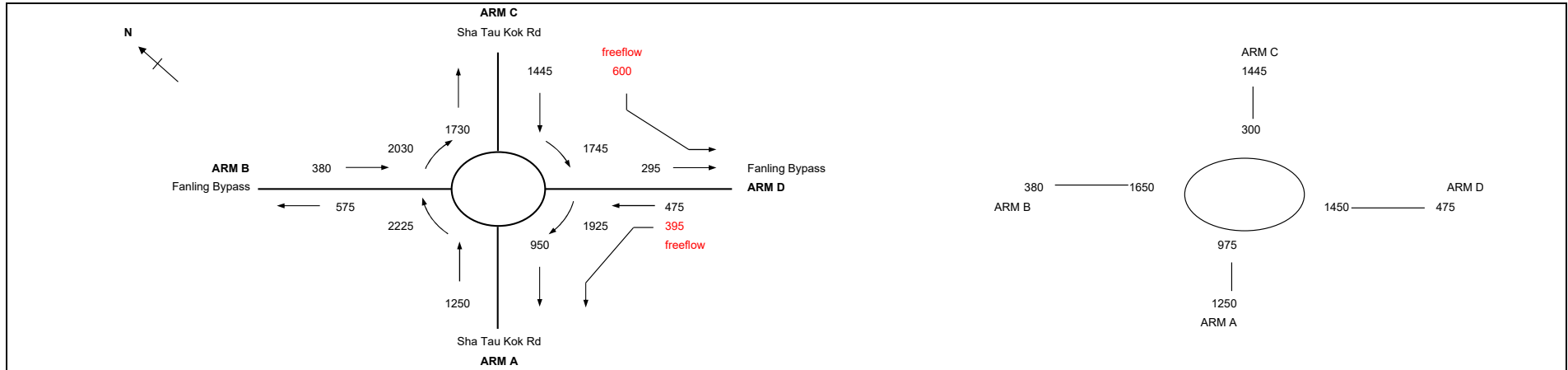

ARM	A	B	C	D
INPUT PARAMETERS:				
V = Approach half width (m)	7.30	4.50	7.30	4.50
E = Entry width (m)	10.00	7.00	10.00	7.00
L = Effective length of flare (m)	30	10	15	25
R = Entry radius (m)	50	20	20	10
D = Inscribed circle diameter (m)	75	75	75	75
A = Entry angle (degree)	10	25	20	25
Q = Entry flow (pcu/h)	1250	380	1445	475
Qc = Circulating flow across entry (pcu/h)	975	1650	300	1450
OUTPUT PARAMETERS:				
S = Sharpness of flare = 1.6(E-V)/L	0.14	0.40	0.29	0.16
K = 1-0.00347(A-30)-0.978(1/R-0.05)	1.10	1.02	1.03	0.97
X2 = $V + ((E-V)/(1+2S))$	9.40	5.89	9.01	6.39
M = $EXP((D-60)/10)$	4.48	4.48	4.48	4.48
F = 303*X2	2847	1784	2731	1937
Td = 1+(0.5/(1+M))	1.09	1.09	1.09	1.09
Fc = 0.21*Td(1+0.2*X2)	0.66	0.50	0.64	0.52
Qe = K(F-Fc*Qc)	2421	978	2626	1143
DFC = Design flow/Capacity = Q/Qe	0.52	0.39	0.56	0.42
Total In Sum = 3550 PCU				
DFC of Critical Approach = 0.56				

J16 - Sha Tau Kok Road / Fanling Bypass

J16_2031_REF_PM

DATE 16/12/2024

PROJECT NO. 287082

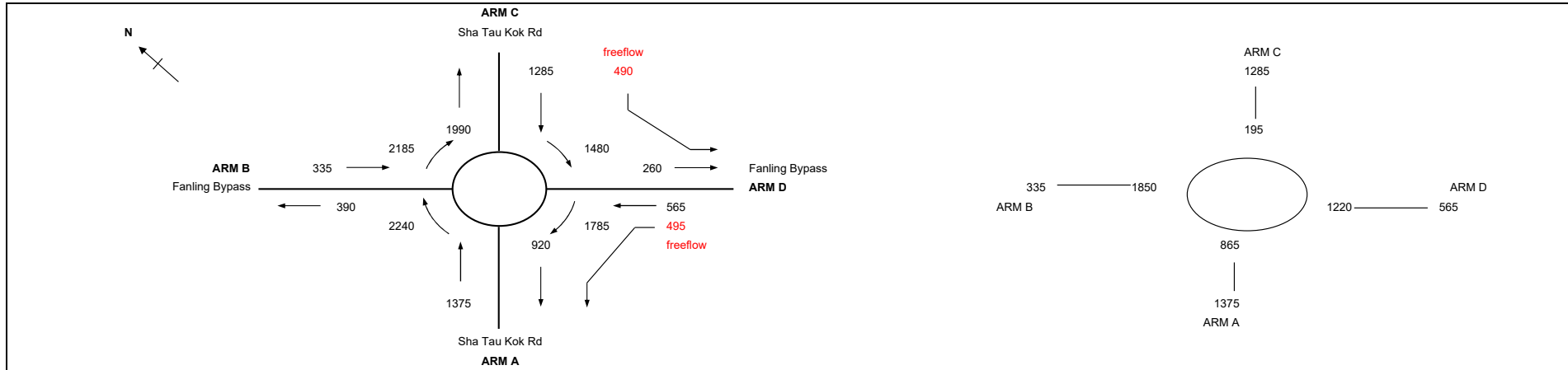

ARM	A	B	C	D			
INPUT PARAMETERS:							
V =	Approach half width (m)	7.30	4.50	7.30	4.50		
E =	Entry width (m)	10.00	7.00	10.00	7.00		
L =	Effective length of flare (m)	30	10	15	25		
R =	Entry radius (m)	50	20	20	10		
D =	Inscribed circle diameter (m)	75	75	75	75		
A =	Entry angle (degree)	10	25	20	25		
Q =	Entry flow (pcu/h)	1375	335	1285	565		
Qc =	Circulating flow across entry (pcu/h)	865	1850	195	1220		
OUTPUT PARAMETERS:							
S =	Sharpness of flare = $1.6(E-V)/L$	0.14	0.40	0.29	0.16		
K =	$1-0.00347(A-30)-0.978(1/R-0.05)$	1.10	1.02	1.03	0.97		
X2 =	$V + ((E-V)/(1+2S))$	9.40	5.89	9.01	6.39		
M =	$EXP((D-60)/10)$	4.48	4.48	4.48	4.48		
F =	$303 \times X2$	2847	1784	2731	1937		
Td =	$1+(0.5/(1+M))$	1.09	1.09	1.09	1.09		
Fc =	$0.21 \times Td(1+0.2 \times X2)$	0.66	0.50	0.64	0.52		
Qe =	$K(F-Fc \times Qc)$	2501	876	2696	1259		
DFC =	Design flow/Capacity = Q/Qe	0.55	0.39	0.48	0.45		
					Total In Sum =	3560	PCU
					DFC of Critical Approach =	0.55	

J16 - Sha Tau Kok Road / Fanling Bypass

J16_2031_DES_AM

DATE 16/12/2024

PROJECT NO. 287082

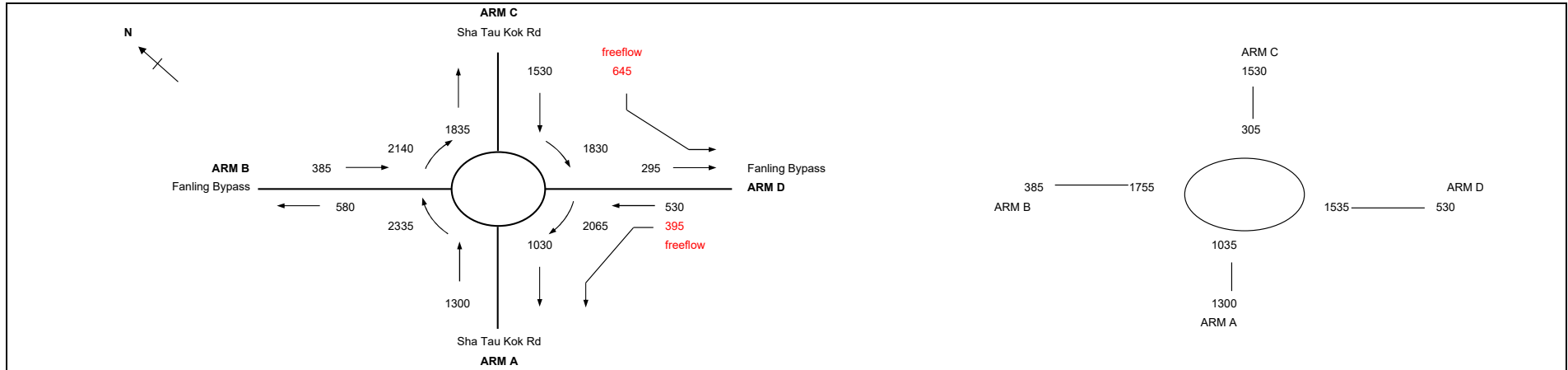

ARM	A	B	C	D
INPUT PARAMETERS:				
V = Approach half width (m)	7.30	4.50	7.30	4.50
E = Entry width (m)	10.00	7.00	10.00	7.00
L = Effective length of flare (m)	30	10	15	25
R = Entry radius (m)	50	20	20	10
D = Inscribed circle diameter (m)	75	75	75	75
A = Entry angle (degree)	10	25	20	25
Q = Entry flow (pcu/h)	1300	385	1530	530
Qc = Circulating flow across entry (pcu/h)	1035	1755	305	1535
OUTPUT PARAMETERS:				
S = Sharpness of flare = 1.6(E-V)/L	0.14	0.40	0.29	0.16
K = 1-0.00347(A-30)-0.978(1/R-0.05)	1.10	1.02	1.03	0.97
X2 = $V + ((E-V)/(1+2S))$	9.40	5.89	9.01	6.39
M = $EXP((D-60)/10)$	4.48	4.48	4.48	4.48
F = 303*X2	2847	1784	2731	1937
Td = 1+(0.5/(1+M))	1.09	1.09	1.09	1.09
Fc = 0.21*Td(1+0.2*X2)	0.66	0.50	0.64	0.52
Qe = K(F-Fc*Qc)	2378	924	2623	1100
DFC = Design flow/Capacity = Q/Qe	0.55	0.42	0.59	0.49
Total In Sum = 3745 PCU				
DFC of Critical Approach = 0.59				

J16 - Sha Tau Kok Road / Fanling Bypass

J16_2031_DES_PM

DATE 16/12/2024

PROJECT NO. 287082

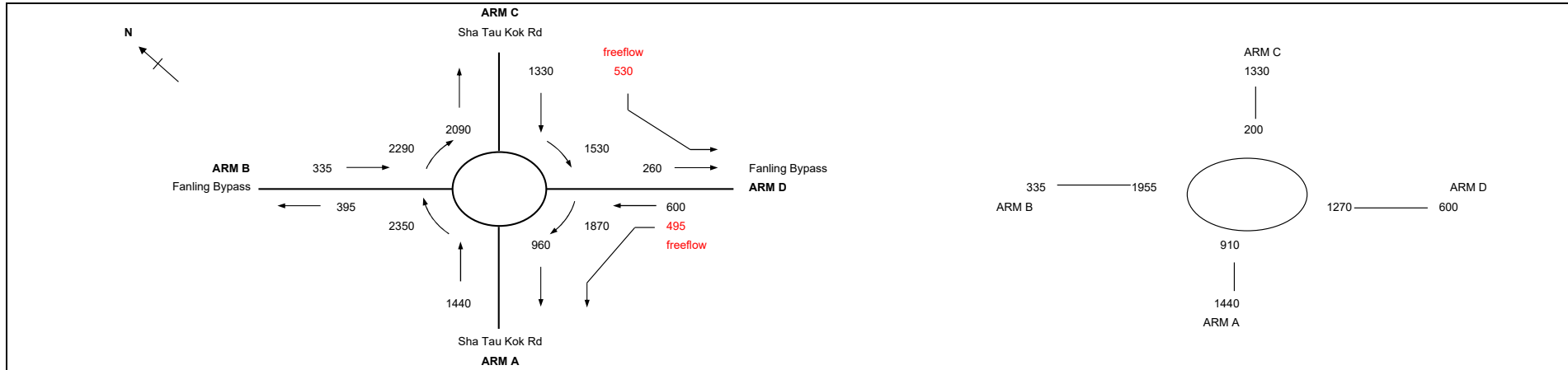

ARM	A	B	C	D
INPUT PARAMETERS:				
V = Approach half width (m)	7.30	4.50	7.30	4.50
E = Entry width (m)	10.00	7.00	10.00	7.00
L = Effective length of flare (m)	30	10	15	25
R = Entry radius (m)	50	20	20	10
D = Inscribed circle diameter (m)	75	75	75	75
A = Entry angle (degree)	10	25	20	25
Q = Entry flow (pcu/h)	1440	335	1330	600
Qc = Circulating flow across entry (pcu/h)	910	1955	200	1270
OUTPUT PARAMETERS:				
S = Sharpness of flare = 1.6(E-V)/L	0.14	0.40	0.29	0.16
K = 1-0.00347(A-30)-0.978(1/R-0.05)	1.10	1.02	1.03	0.97
X2 = V + ((E-V)/(1+2S))	9.40	5.89	9.01	6.39
M = EXP((D-60)/10)	4.48	4.48	4.48	4.48
F = 303*X2	2847	1784	2731	1937
Td = 1+(0.5/(1+M))	1.09	1.09	1.09	1.09
Fc = 0.21*Td(1+0.2*X2)	0.66	0.50	0.64	0.52
Qe = K(F-Fc*Qc)	2468	823	2693	1234
DFC = Design flow/Capacity = Q/Qe	0.59	0.41	0.50	0.49
Total In Sum = 3705 PCU				
DFC of Critical Approach = 0.59				

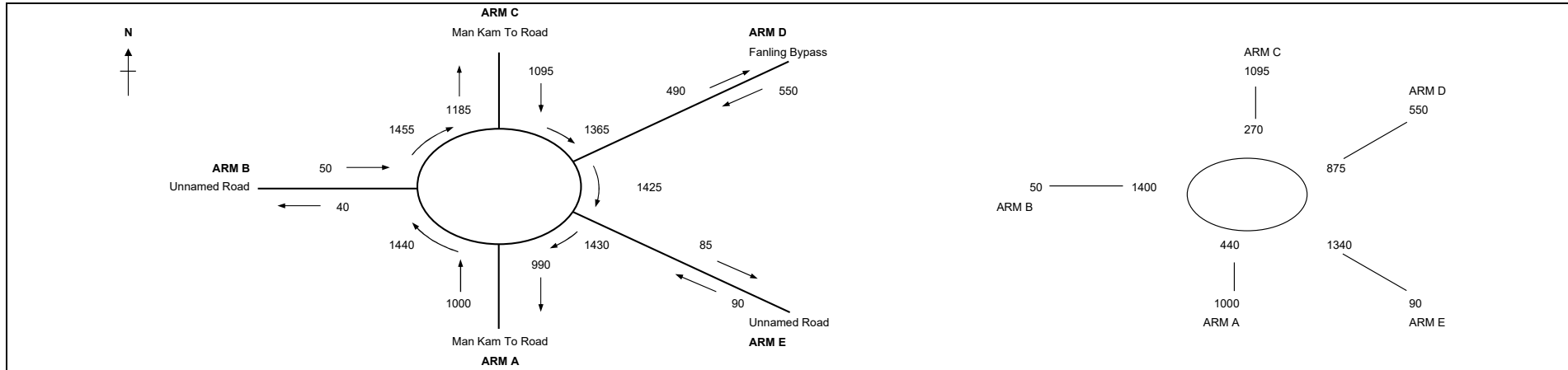

ARM	A	B	C	D	E		
INPUT PARAMETERS:							
V = Approach half width (m)	7.00	3.30	5.00	4.50	3.00		
E = Entry width (m)	10.00	5.00	8.00	8.00	5.00		
L = Effective length of flare (m)	5	20	10	10	20		
R = Entry radius (m)	20	20	50	40	15		
D = Inscribed circle diameter (m)	80	80	80	80	80		
A = Entry angle (degree)	35	20	15	25	35		
Q = Entry flow (pcu/h)	1000	50	1095	550	90		
Qc = Circulating flow across entry (pcu/h)	440	1400	270	875	1340		
OUTPUT PARAMETERS:							
S = Sharpness of flare = 1.6(E-V)/L	0.96	0.14	0.48	0.56	0.16		
K = 1-0.00347(A-30)-0.978(1/R-0.05)	0.98	1.03	1.08	1.04	0.97		
X2 = V + ((E-V)/(1+2S))	8.03	4.64	6.53	6.15	4.52		
M = EXP((D-60)/10)	7.39	7.39	7.39	7.39	7.39		
F = 303*X2	2432	1405	1979	1864	1368		
Td = 1+(0.5/(1+M))	1.06	1.06	1.06	1.06	1.06		
Fc = 0.21*Td(1+0.2*X2)	0.58	0.43	0.51	0.50	0.42		
Qe = K(F-Fc*Qc)	2139	832	1990	1489	774	Total In Sum =	2145 PCU
DFC = Design flow/Capacity = Q/Qe	0.47	0.07	0.56	0.37	0.12	DFC of Critical Approach =	0.56

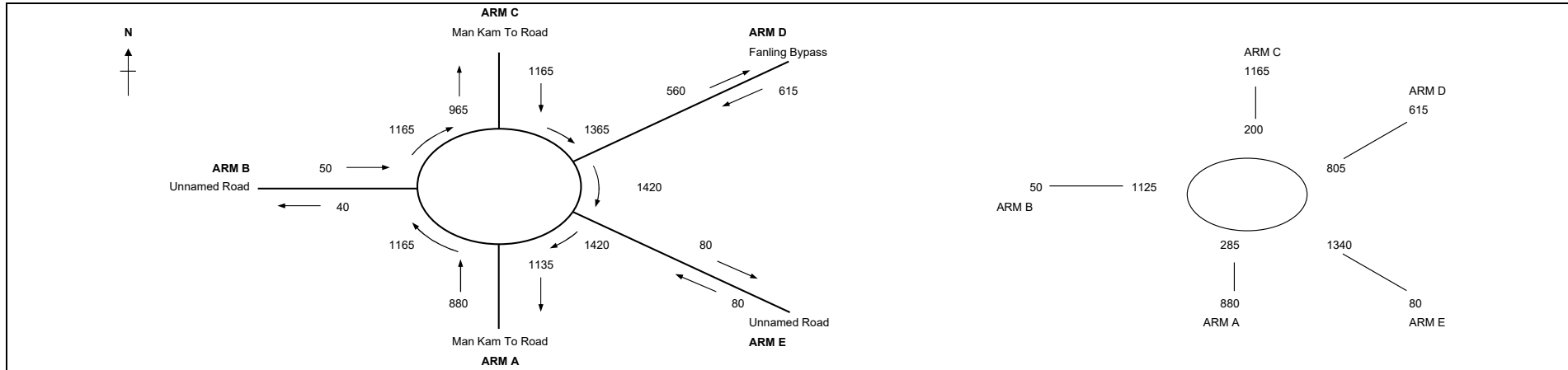

ARM	A	B	C	D	E		
INPUT PARAMETERS:							
V = Approach half width (m)	7.00	3.30	5.00	4.50	3.00		
E = Entry width (m)	10.00	5.00	8.00	8.00	5.00		
L = Effective length of flare (m)	5	20	10	10	20		
R = Entry radius (m)	20	20	50	40	15		
D = Inscribed circle diameter (m)	80	80	80	80	80		
A = Entry angle (degree)	35	20	15	25	35		
Q = Entry flow (pcu/h)	880	50	1165	615	80		
Qc = Circulating flow across entry (pcu/h)	285	1125	200	805	1340		
OUTPUT PARAMETERS:							
S = Sharpness of flare = 1.6(E-V)/L	0.96	0.14	0.48	0.56	0.16		
K = 1-0.00347(A-30)-0.978(1/R-0.05)	0.98	1.03	1.08	1.04	0.97		
X2 = V + ((E-V)/(1+2S))	8.03	4.64	6.53	6.15	4.52		
M = EXP((D-60)/10)	7.39	7.39	7.39	7.39	7.39		
F = 303*X2	2432	1405	1979	1864	1368		
Td = 1+(0.5/(1+M))	1.06	1.06	1.06	1.06	1.06		
Fc = 0.21*Td(1+0.2*X2)	0.58	0.43	0.51	0.50	0.42		
Qe = K(F-Fc*Qc)	2228	954	2029	1525	774	Total In Sum =	2095 PCU
DFC = Design flow/Capacity = Q/Qe	0.40	0.06	0.58	0.41	0.11	DFC of Critical Approach =	0.58

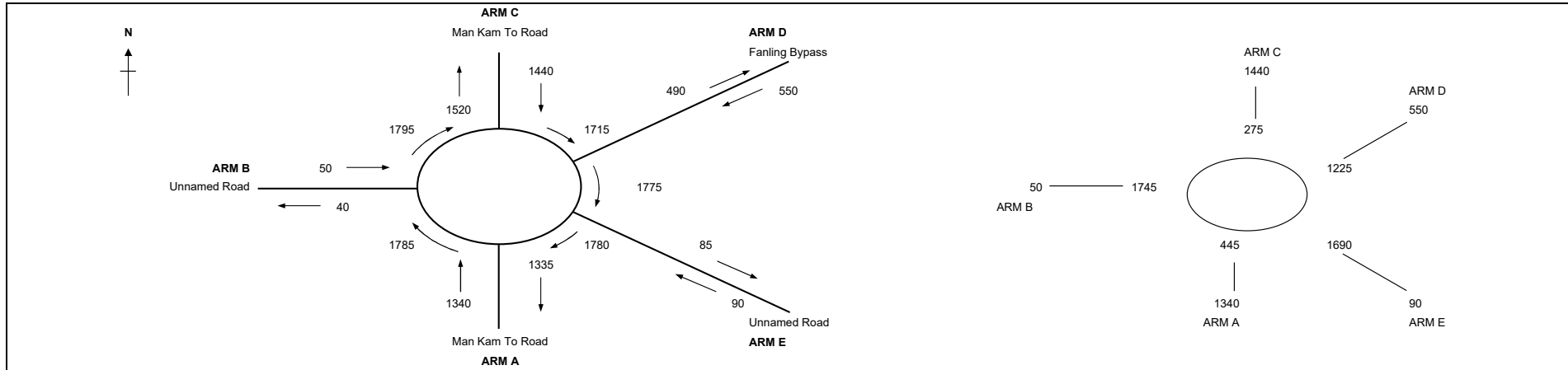

ARM	A	B	C	D	E		
INPUT PARAMETERS:							
V = Approach half width (m)	7.00	3.30	5.00	4.50	3.00		
E = Entry width (m)	10.00	5.00	8.00	8.00	5.00		
L = Effective length of flare (m)	5	20	10	10	20		
R = Entry radius (m)	20	20	50	40	15		
D = Inscribed circle diameter (m)	80	80	80	80	80		
A = Entry angle (degree)	35	20	15	25	35		
Q = Entry flow (pcu/h)	1340	50	1440	550	90		
Qc = Circulating flow across entry (pcu/h)	445	1745	275	1225	1690		
OUTPUT PARAMETERS:							
S = Sharpness of flare = 1.6(E-V)/L	0.96	0.14	0.48	0.56	0.16		
K = 1-0.00347(A-30)-0.978(1/R-0.05)	0.98	1.03	1.08	1.04	0.97		
X2 = V + ((E-V)/(1+2S))	8.03	4.64	6.53	6.15	4.52		
M = EXP((D-60)/10)	7.39	7.39	7.39	7.39	7.39		
F = 303*X2	2432	1405	1979	1864	1368		
Td = 1+(0.5/(1+M))	1.06	1.06	1.06	1.06	1.06		
Fc = 0.21*Td(1+0.2*X2)	0.58	0.43	0.51	0.50	0.42		
Qe = K(F-Fc*Qc)	2137	679	1987	1308	630	Total In Sum =	2830 PCU
DFC = Design flow/Capacity = Q/Qe	0.63	0.08	0.73	0.43	0.15	DFC of Critical Approach =	0.73

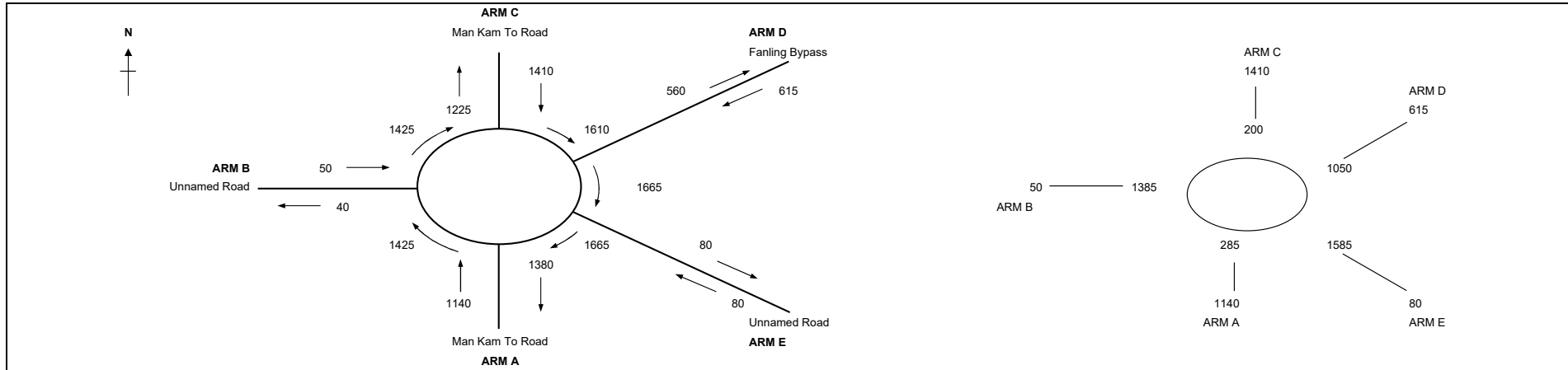

ARM	A	B	C	D	E		
INPUT PARAMETERS:							
V = Approach half width (m)	7.00	3.30	5.00	4.50	3.00		
E = Entry width (m)	10.00	5.00	8.00	8.00	5.00		
L = Effective length of flare (m)	5	20	10	10	20		
R = Entry radius (m)	20	20	50	40	15		
D = Inscribed circle diameter (m)	80	80	80	80	80		
A = Entry angle (degree)	35	20	15	25	35		
Q = Entry flow (pcu/h)	1140	50	1410	615	80		
Qc = Circulating flow across entry (pcu/h)	285	1385	200	1050	1585		
OUTPUT PARAMETERS:							
S = Sharpness of flare = 1.6(E-V)/L	0.96	0.14	0.48	0.56	0.16		
K = 1-0.00347(A-30)-0.978(1/R-0.05)	0.98	1.03	1.08	1.04	0.97		
X2 = V + ((E-V)/(1+2S))	8.03	4.64	6.53	6.15	4.52		
M = EXP((D-60)/10)	7.39	7.39	7.39	7.39	7.39		
F = 303*X2	2432	1405	1979	1864	1368		
Td = 1+(0.5/(1+M))	1.06	1.06	1.06	1.06	1.06		
Fc = 0.21*Td(1+0.2*X2)	0.58	0.43	0.51	0.50	0.42		
Qe = K(F-Fc*Qc)	2228	839	2029	1399	673	Total In Sum =	2600 PCU
DFC = Design flow/Capacity = Q/Qe	0.52	0.06	0.70	0.44	0.12	DFC of Critical Approach =	0.70

J18 - Jockey Club Road / Road L4

J18_2031_REF_AM

PROJECT NO:

Junction No. J18

DATE : 16/12/2024

FILENAME :

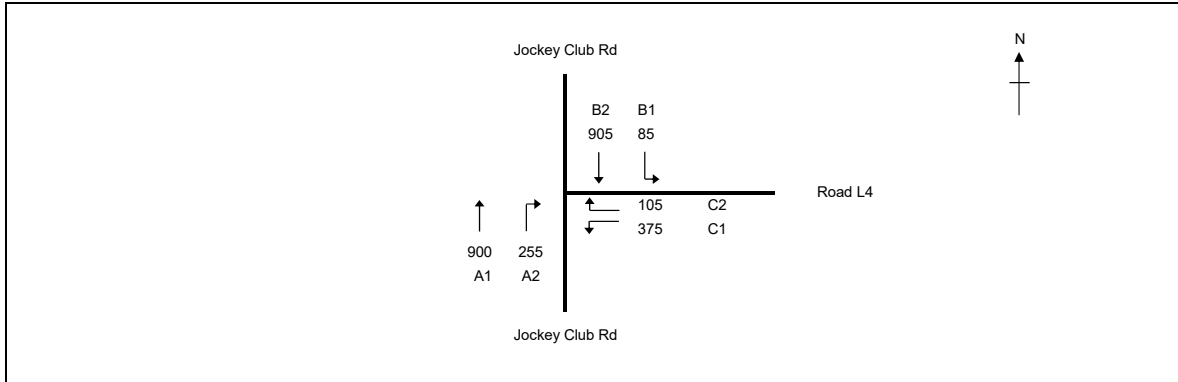

No. of stages per cycle	N =	4
No. of stage using for calculation	N =	2
Cycle time	C =	120 sec
Sum(y)	Y =	0.434
Loss time	L =	28 sec
Total Flow	=	2625 pcu
Co	= (1.5*L+5)/(1-Y)	= 83.0 sec
Cm	= L/(1-Y)	= 49.5 sec
Yult	=	0.690
R.C.ult	= (Yult-Y)*Y*100%	= 59.0 %
Cp	= 0.9*L/(0.9-Y)	= 54.1 sec
Ymax	= 1-L/C	= 0.767
R.C.(C)	= (0.9*Ymax-Y)*Y*100%	= 58 %

	B1,B2 ↓ ↓						
	A1,A2 ↑ ↑	A1,A2 ↑ ↑			C1,C2 ← →		D ↑ ↓
STAGE 1	INT=	STAGE 2	INT=	6	STAGE 3	INT=	6

Pedestrian Phase	Width (m)	Green Time Required (s)			Green Time Provided (s)			Check
		SG	Delay	FG	SG	Delay	FG	
D	9	8	2	8	8	2	8	OK

Move-ment	Stage	Lane Width m.	Phase	No. of lane	Radius m.	O	N	Straight-Ahead Sat. Flow	Flow			Total Flow pcu/h	Proportion of Turning Vehicles	Sat. Flow pcu/h	Uphill Gradient %	Short lane Effect pcu/h	Revised Sat. Flow pcu/h	y	Greater y	L sec	g (required) sec	g (input) sec	Degree of Saturation X	Queuing Length m.
									Left pcu/h	Straight pcu/h	Right pcu/h													
A1	1,2	3.50	C	1			N	1965		601		601	0.00	1965		1965	0.306	0.306	10	65	65	0.566	55	
A1,A2	1,2	3.50	C	1	20	O	N	2105		299	255	554	0.46	1812		1812	0.306			65	65	0.566	51	
B1,B2	1	3.50	B	1	20		N	1965	85	390		475	0.18	1939		1939	0.245			52	52	0.566	54	
B2	1	3.50	B	1			N	2105		515		515	0.00	2105		2105	0.245			52	52	0.565	58	
C1	3	3.50	D	1	15		N	1965	229			229	1.00	1786		1786	0.128	0.128		27	27	0.566	35	
C1,C2	3	3.50	D	1	20		N	2105	146		105	251	1.00	1958		1958	0.128			27	27	0.566	39	
	4		PED																18					

NOTE : 'O' - OPPOSING TRAFFIC

N - NEAR SIDE LANE

SG - STEADY GREEN

FG - FLASHING GREEN

PEDESTRIAN WALKING SPEED FOR SG(FG) = 1.2(0.9)m/s

QUEUING LENGTH = AVERAGE QUEUE * 6m

J18 - Jockey Club Road / Road L4

J18_2031_REF_PM

PROJECT NO:

Junction No. J18

DATE : 16/12/2024

FILENAME :

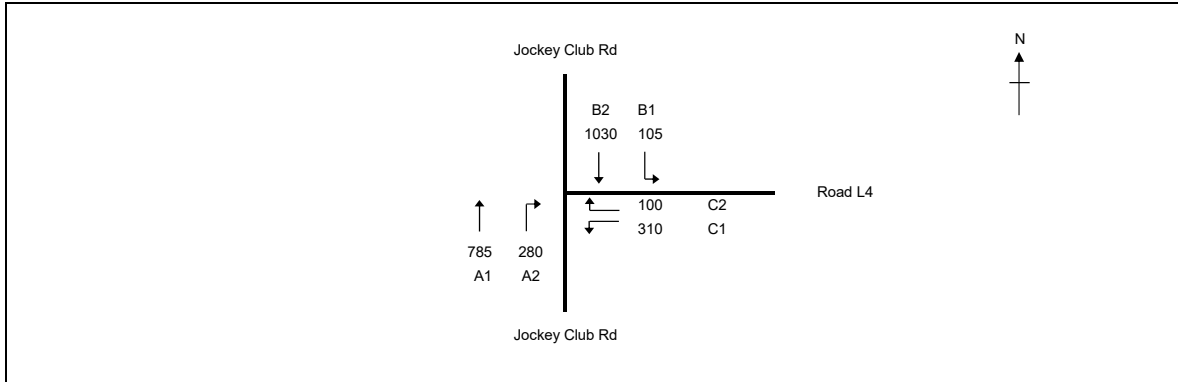

No. of stages per cycle	N = 4
No. of stage using for calculation	N = 2
Cycle time	C = 120 sec
Sum(y)	Y = 0.391
Loss time	L = 33 sec
Total Flow	= 2610 pcu
Co	= (1.5*L+5)/(1-Y) = 89.4 sec
Cm	= L/(1-Y) = 54.1 sec
Yult	= 0.653
R.C.ult	= (Yult-Y)*100% = 67.1 %
Cp	= 0.9*L/(0.9-Y) = 58.3 sec
Ymax	= 1-L/C = 0.725
R.C.(C)	= (0.9*Ymax-Y)*100% = 67 %

	B1,B2 ↓ ↓						
	↑ ↑ A1,A2		↑ ↑ A1,A2		← → C1,C2		D ↑ ↓
STAGE 1	INT= 5	STAGE 2	INT= 6	STAGE 3	INT= 6	STAGE 4	INT=

Pedestrian Phase	Width (m)	Green Time Required (s)			Green Time Provided (s)			Check
		SG	Delay	FG	SG	Delay	FG	
D	9	8	2	8	8	2	8	OK

Move-ment	Stage	Lane Width m.	Phase	No. of lane	Radius m.	O	N	Straight-Ahead Sat. Flow	Flow			Total Flow pcu/h	Proportion of Turning Vehicles	Sat. Flow pcu/h	Uphill Gradient %	Short lane Effect pcu/h	Revised Sat. Flow pcu/h	y	Greater y	L sec	g (required) sec	g (input) sec	Degree of Saturation X	Queuing Length m.	
									Left pcu/h	Straight pcu/h	Right pcu/h														
A1	1,2	3.50	C	1			N	1965		556		556	0.00	1965					15						
A1,A2	1,2	3.50	C	1	20	O	N	2105		229	280	509	0.55	1801			1965	0.283			63	69	0.495	48	
B1,B2	1	3.50	B	1	20		N	1965	105	439		544	0.19	1937			1937	0.281	0.281		63	63	0.539	52	
B2	1	3.50	B	1			N	2105		591		591	0.00	2105			2105	0.281			63	63	0.539	57	
C1	3	3.50	D	1	15		N	1965	196			196	1.00	1786			1786	0.110	0.110		24	24	0.539	31	
C1,C2	3	3.50	D	1	20		N	2105	114		100	214	1.00	1958			1958	0.109			24	24	0.537	34	
	4		PED																18						

NOTE : 'O' - OPPOSING TRAFFIC

N - NEAR SIDE LANE

SG - STEADY GREEN

FG - FLASHING GREEN

PEDESTRIAN WALKING SPEED FOR SG(FG) = 1.2(0.9)m/s

QUEUING LENGTH = AVERAGE QUEUE * 6m

J18 - Jockey Club Road / Road L4

J18_2031_DES_AM

PROJECT NO:

Junction No. J18

DATE : 16/12/2024

FILENAME :

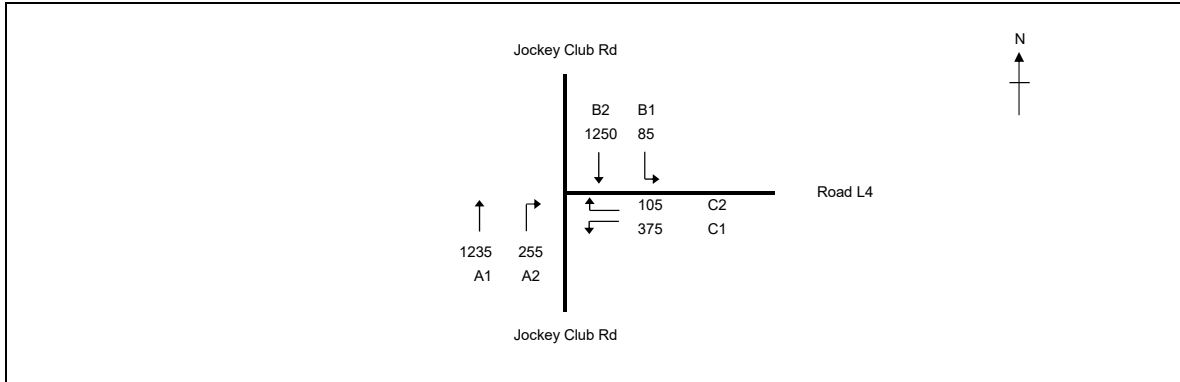

No. of stages per cycle	N =	4
No. of stage using for calculation	N =	2
Cycle time	C =	120 sec
Sum(y)	Y =	0.521
Loss time	L =	28 sec
Total Flow	=	3305 pcu
Co	= (1.5*L+5)/(1-Y)	= 98.2 sec
Cm	= L/(1-Y)	= 58.5 sec
Yult	=	0.690
R.C.ult	= (Yult-Y)*Y*100%	= 32.4 %
Cp	= 0.9*L/(0.9-Y)	= 66.5 sec
Ymax	= 1-L/C	= 0.767
R.C.(C)	= (0.9*Ymax-Y)*Y*100%	= 32 %

	B1,B2 ↓ ↓						
A1,A2 ↑ ↑		A1,A2 ↑ ↑			C1,C2 ← →		D ↑ ↓
STAGE 1	INT=	STAGE 2	INT=	6	STAGE 3	INT=	6

Pedestrian Phase	Width (m)	Green Time Required (s)			Green Time Provided (s)			Check
		SG	Delay	FG	SG	Delay	FG	
D	9	8	2	8	8	2	8	OK

Move-ment	Stage	Lane Width m.	Phase	No. of lane	Radius m.	O	N	Straight-Ahead Sat. Flow	Flow			Total Flow pcu/h	Proportion of Turning Vehicles	Sat. Flow pcu/h	Uphill Gradient %	Short lane Effect pcu/h	Revised Sat. Flow pcu/h	y	Greater y	L sec	g (required) sec	g (input) sec	Degree of Saturation X	Queuing Length m.
									Left pcu/h	Straight pcu/h	Right pcu/h													
A1	1,2	3.50	C	1			N	1965		772		772	0.00	1965		1965	0.393	0.393	10	69	69	0.680	65	
A1,A2	1,2	3.50	C	1	20	O	N	2105		463	255	718	0.36	1826		1826	0.393			69	69	0.680	61	
B1,B2	1	3.50	B	1	20		N	1965	85	556		641	0.13	1946		1946	0.329			58	58	0.680	66	
B2	1	3.50	B	1			N	2105		694		694	0.00	2105		2105	0.330			58	58	0.680	72	
C1	3	3.50	D	1	15		N	1965	229			229	1.00	1786		1786	0.128	0.128		23	23	0.680	37	
C1,C2	3	3.50	D	1	20		N	2105	146		105	251	1.00	1958		1958	0.128			23	23	0.680	41	
	4		PED																18					

NOTE : 'O' - OPPOSING TRAFFIC

N - NEAR SIDE LANE

SG - STEADY GREEN

FG - FLASHING GREEN

PEDESTRIAN WALKING SPEED FOR SG(FG) = 1.2(0.9)m/s

QUEUING LENGTH = AVERAGE QUEUE * 6m

J18 - Jockey Club Road / Road L4

J18_2031_DES_PM

PROJECT NO:

Junction No. J18

DATE : 16/12/2024

FILENAME :

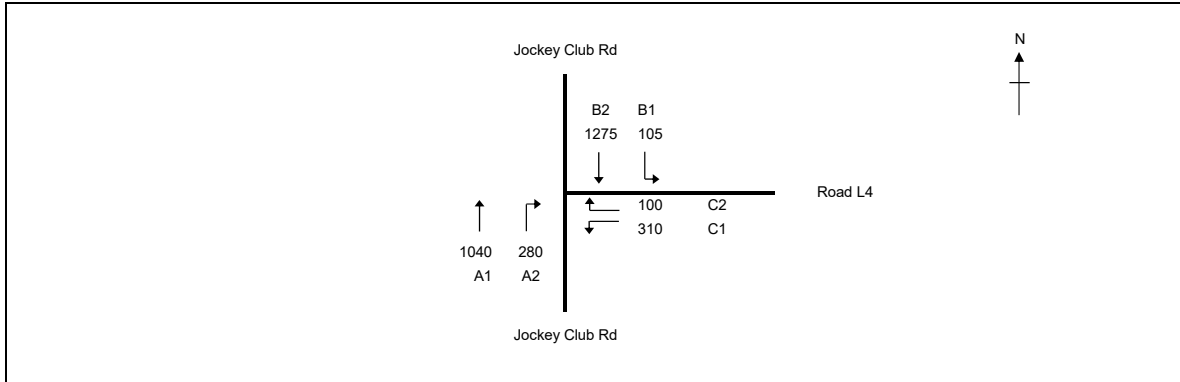

No. of stages per cycle	N =	4
No. of stage using for calculation	N =	2
Cycle time	C =	120 sec
Sum(y)	Y =	0.451
Loss time	L =	33 sec
Total Flow	=	3110 pcu
Co	= (1.5*L+5)/(1-Y)	= 99.2 sec
Cm	= L/(1-Y)	= 60.1 sec
Yult	=	0.653
R.C.ult	= (Yult-Y)*Y*100%	= 44.7 %
Cp	= 0.9*L/(0.9-Y)	= 66.1 sec
Ymax	= 1-L/C	= 0.725
R.C.(C)	= (0.9*Ymax-Y)*Y*100%	= 44 %

	B1,B2						
	A1,A2	A1,A2		C1,C2			
STAGE 1	INT= 5	STAGE 2	INT= 6	STAGE 3	INT= 6	STAGE 4	INT=

Pedestrian Phase	Width (m)	Green Time Required (s)			Green Time Provided (s)			Check
		SG	Delay	FG	SG	Delay	FG	
D	9	8	2	8	8	2	8	OK

Move-ment	Stage	Lane Width m.	Phase	No. of lane	Radius m.	O	N	Straight-Ahead Sat. Flow	Flow			Total Flow pcu/h	Proportion of Turning Vehicles	Sat. Flow pcu/h	Uphill Gradient %	Short lane Effect pcu/h	Revised Sat. Flow pcu/h	y	Greater y	L sec	g (required) sec	g (input) sec	Degree of Saturation X	Queuing Length m.
									Left pcu/h	Straight pcu/h	Right pcu/h													
A1	1,2	3.50	C	1			N	1965		686		686	0.00	1965					15					
A1,A2	1,2	3.50	C	1	20	O	N	2105		354	280	634	0.44	1815			1965	0.349			67	72	0.584	55
B1,B2	1	3.50	B	1	20		N	1965	105	557		662	0.16	1942			1942	0.341	0.341		66	66	0.622	60
B2	1	3.50	B	1			N	2105		718		718	0.00	2105			2105	0.341			66	66	0.622	65
C1	3	3.50	D	1	15		N	1965	196			196	1.00	1786			1786	0.110	0.110		21	21	0.622	32
C1,C2	3	3.50	D	1	20		N	2105	114		100	214	1.00	1958			1958	0.109			21	21	0.619	35
	4		PED																18					

NOTE : 'O' - OPPOSING TRAFFIC

N - NEAR SIDE LANE

SG - STEADY GREEN

FG - FLASHING GREEN

PEDESTRIAN WALKING SPEED FOR SG(FG) = 1.2(0.9)m/s

QUEUING LENGTH = AVERAGE QUEUE * 6m

J19 - Sha Tau Kok Road / Luen On Street

J19_2023_EXT_AM

PROJECT NO: 287082

Junction No. J19

DATE : 16/12/2024

FILENAME :

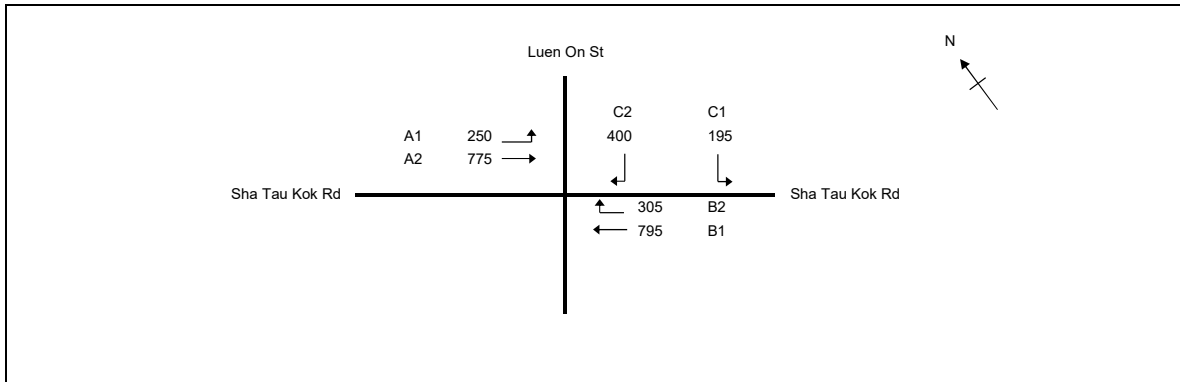

No. of stages per cycle	N = 3
No. of stage using for calculation	N = 3
Cycle time	C = 90 sec
Sum(y)	Y = 0.453
Loss time	L = 15 sec
Total Flow	= 2720 pcu
Co	= (1.5*L+5)/(1-Y) = 50.3 sec
Cm	= L/(1-Y) = 27.4 sec
Yult	= 0.788
R.C.ult	= (Yult-Y)/Y*100% = 73.7 %
Cp	= 0.9*L/(0.9-Y) = 30.2 sec
Ymax	= 1-L/C = 0.833
R.C.(C)	= (0.9*Ymax-Y)/Y*100% = 65 %

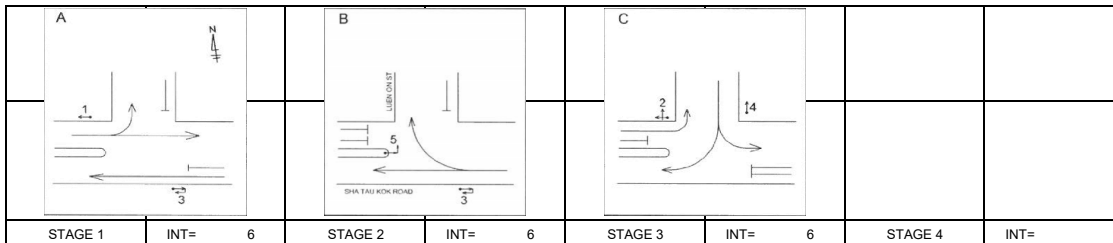

Pedestrian Phase	Width (m)	Green Time Required (s)			Green Time Provided (s)			Check
		SG	Delay	FG	SG	Delay	FG	

Move-ment	Stage	Lane Width m.	Phase	No. of lane	Radius m.	O	N	Straight-Ahead Sat. Flow	Flow			Total Flow pcu/h	Proportion of Turning Vehicles	Sat. Flow pcu/h	Uphill Gradient %	Short lane Effect pcu/h	Revised Sat. Flow pcu/h	y	Greater y	L sec	g (required) sec	g (input) sec	Degree of Saturation X	Queuing Length m.
									Left pcu/h	Straight pcu/h	Right pcu/h													
A1	1,3	3.50	2	1	15		N	1965	250			250	1.00	1786			1786	0.140		15	23	55	0.230	15
A2	1	3.50	1	2				4210		775		775	0.00	4210			4210	0.184	0.184		30	30	0.544	38
B1	1,2	3.10	3	1			N	1925		384		384	0.00	1925			1925	0.199			33	62	0.291	18
B1	1,2	3.10	3	1				2065		411		411	0.00	2065			2065	0.199			33	62	0.290	19
B2	2	3.10	5	1	20			2065			305	305	1.00	1921			1921	0.159	0.159		26	26	0.544	32
C1	3	3.40	4	1	10		N	1955	188			188	1.00	1700			1700	0.111	0.111		18	18	0.544	22
C1,C2	3	3.40	4	1	12.5			2095	7		199	206	1.00	1871			1871	0.110			18	18	0.542	25
C2	3	3.40	4	1	10			2095			201	201	1.00	1822			1822	0.110			18	18	0.543	24

NOTE : 'O' - OPPOSING TRAFFIC

N - NEAR SIDE LANE

SG - STEADY GREEN

FG - FLASHING GREEN

PEDESTRIAN WALKING SPEED FOR SG(FG) = 1.2(0.9)m/s

QUEUING LENGTH = AVERAGE QUEUE * 6m

J19 - Sha Tau Kok Road / Luen On Street

J19_2023_EXT_PM

PROJECT NO: 287082

Junction No. J19

DATE : 16/12/2024

FILENAME :

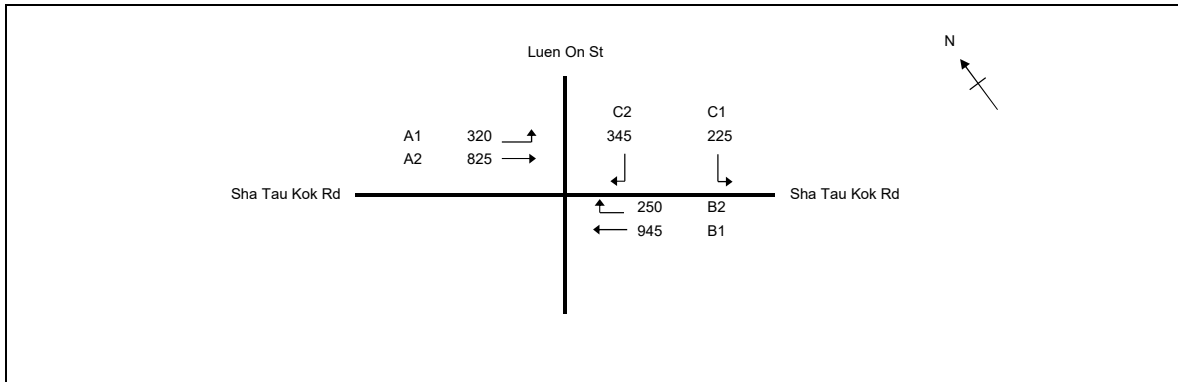

No. of stages per cycle	N = 3
No. of stage using for calculation	N = 3
Cycle time	C = 90 sec
Sum(y)	Y = 0.432
Loss time	L = 15 sec
Total Flow	= 2910 pcu
Co	= (1.5*L+5)/(1-Y) = 48.4 sec
Cm	= L/(1-Y) = 26.4 sec
Yult	= 0.788
R.C.ult	= (Yult-Y)/Y*100% = 82.3 %
Cp	= 0.9*L/(0.9-Y) = 28.8 sec
Ymax	= 1-L/C = 0.833
R.C.(C)	= (0.9*Ymax-Y)/Y*100% = 74 %

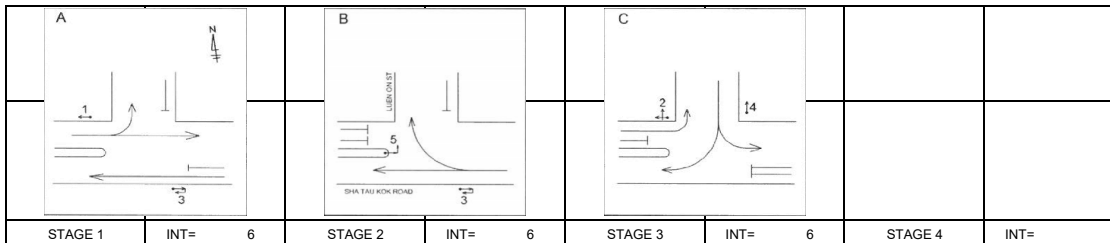

Pedestrian Phase	Width (m)	Green Time Required (s)		Green Time Provided (s)		Check
		SG	Delay FG	SG	Delay FG	

Movement	Stage	Lane Width m.	Phase	No. of lane	Radius m.	O	N	Straight-Ahead Sat. Flow	Flow			Total Flow pcu/h	Proportion of Turning Vehicles	Sat. Flow pcu/h	Uphill Gradient %	Short lane Effect pcu/h	Revised Sat. Flow pcu/h	y	Greater y	L sec	g (required) sec	g (input) sec	Degree of Saturation X	Queuing Length m.
									Left pcu/h	Straight pcu/h	Right pcu/h													
A1	1,3	3.50	2	1	15		N	1965	320			320	1.00	1786		1786	0.179		15	31	58	0.276	17	
A2	1	3.50	1	2				4210		825		825	0.00	4210		4210	0.196	0.196		34	34	0.518	38	
B1	1,2	3.10	3	1			N	1925		456		456	0.00	1925		1925	0.237			41	62	0.346	22	
B1	1,2	3.10	3	1				2065		489		489	0.00	2065		2065	0.237			41	62	0.346	23	
B2	2	3.10	5	1	20			2065			250	250	1.00	1921		1921	0.130	0.130		23	23	0.518	28	
C1	3	3.40	4	1	10		N	1955	180			180	1.00	1700		1700	0.106	0.106		18	18	0.518	21	
C1,C2	3	3.40	4	1	12.5			2095	45		153	198	1.00	1871		1871	0.106			18	18	0.518	24	
C2	3	3.40	4	1	10			2095			192	192	1.00	1822		1822	0.105			18	18	0.516	23	

NOTE : 'O' - OPPOSING TRAFFIC N - NEAR SIDE LANE SG - STEADY GREEN FG - FLASHING GREEN PEDESTRIAN WALKING SPEED FOR SG(FG) = 1.2(0.9)m/s QUEUING LENGTH = AVERAGE QUEUE * 6m

J19 - Sha Tau Kok Road / Luen On Street

J19_2031_REF_AM

PROJECT NO: 287082

Junction No. J19

DATE : 16/12/2024

FILENAME :

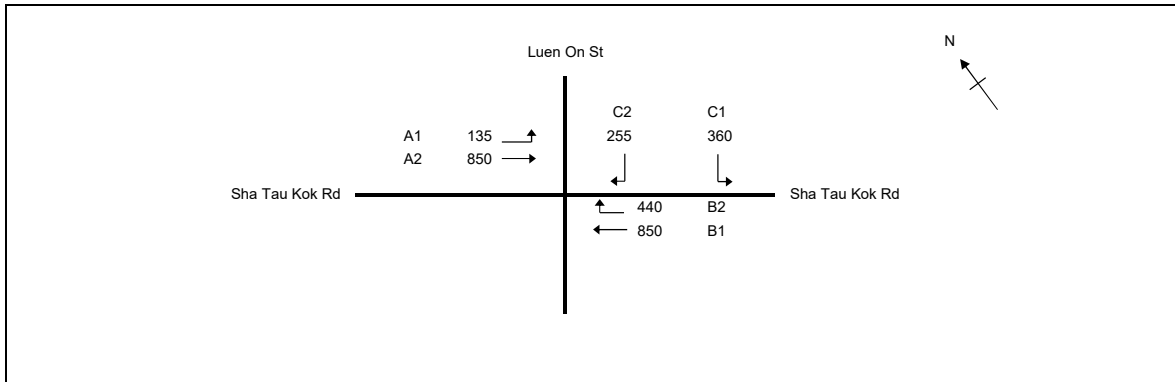

No. of stages per cycle	N = 3
No. of stage using for calculation	N = 3
Cycle time	C = 90 sec
Sum(y)	Y = 0.545
Loss time	L = 15 sec
Total Flow	= 2890 pcu
Co	= (1.5*L+5)/(1-Y) = 60.5 sec
Cm	= L/(1-Y) = 33.0 sec
Yult	= 0.788
R.C.ult	= (Yult-Y)/Y*100% = 44.5 %
Cp	= 0.9*L/(0.9-Y) = 38.0 sec
Ymax	= 1-L/C = 0.833
R.C.(C)	= (0.9*Ymax-Y)/Y*100% = 37 %

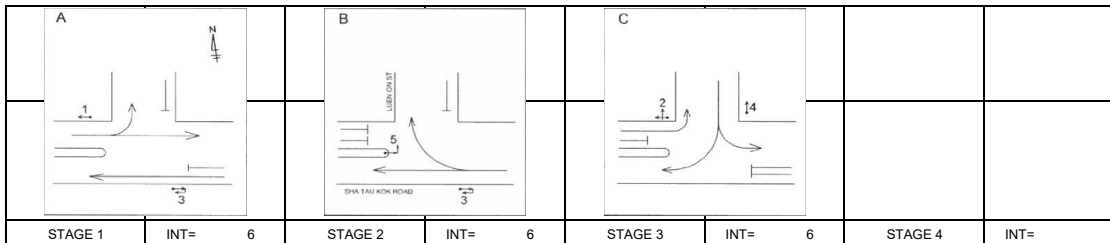

Pedestrian Phase	Width (m)	Green Time Required (s)		Green Time Provided (s)		Check
		SG	Delay FG	SG	Delay FG	

Movement	Stage	Lane Width m.	Phase	No. of lane	Radius m.	O	N	Straight-Ahead Sat. Flow	Flow			Total Flow pcu/h	Proportion of Turning Vehicles	Sat. Flow pcu/h	Uphill Gradient %	Short lane Effect pcu/h	Revised Sat. Flow pcu/h	y	Greater y	L sec	g (required) sec	g (input) sec	Degree of Saturation X	Queuing Length m.
									Left pcu/h	Straight pcu/h	Right pcu/h													
A1	1,3	3.50	2	1	15		N	1965	135			135	1.00	1786			1786	0.076		15	10	49	0.137	9
A2	1	3.50	1	2				4210		850		850	0.00	4210			4210	0.202	0.202		28	28	0.654	44
B1	1,2	3.10	3	1			N	1925		410		410	0.00	1925			1925	0.213		29	64	0.298	18	
B1	1,2	3.10	3	1				2065		440		440	0.00	2065			2065	0.213		29	64	0.298	19	
B2	2	3.10	5	1	20			2065			440	440	1.00	1921			1921	0.229	0.229		32	32	0.654	43
C1	3	3.40	4	1	10		N	1955	194			194	1.00	1700			1700	0.114	0.114		16	16	0.654	24
C1,C2	3	3.40	4	1	12.5			2095	166			213	1.00	1871			1871	0.114			16	16	0.652	26
C2	3	3.40	4	1	10			2095			208	208	1.00	1822			1822	0.114			16	16	0.654	26

NOTE : 'O' - OPPOSING TRAFFIC

N - NEAR SIDE LANE

SG - STEADY GREEN

FG - FLASHING GREEN

PEDESTRIAN WALKING SPEED FOR SG(FG) = 1.2(0.9)m/s

QUEUING LENGTH = AVERAGE QUEUE * 6m

J19 - Sha Tau Kok Road / Luen On Street

J19_2031_REF_PM

PROJECT NO: 287082

Junction No. J19

DATE : 16/12/2024

FILENAME :

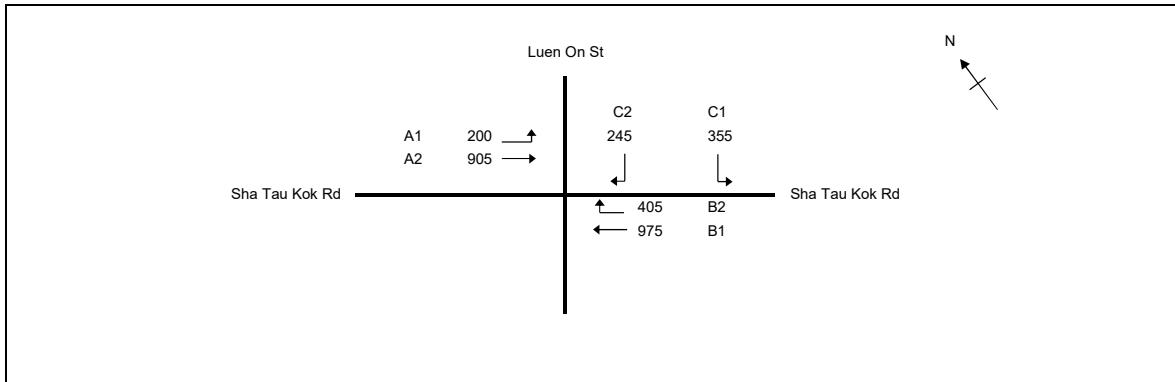

No. of stages per cycle	N = 3
No. of stage using for calculation	N = 3
Cycle time	C = 90 sec
Sum(y)	Y = 0.537
Loss time	L = 15 sec
Total Flow	= 3085 pcu
Co	= (1.5*L+5)/(1-Y) = 59.4 sec
Cm	= L/(1-Y) = 32.4 sec
Yult	= 0.788
R.C.ult	= (Yult-Y)/Y*100% = 46.6 %
Cp	= 0.9*L/(0.9-Y) = 37.2 sec
Ymax	= 1-L/C = 0.833
R.C.(C)	= (0.9*Ymax-Y)/Y*100% = 39 %

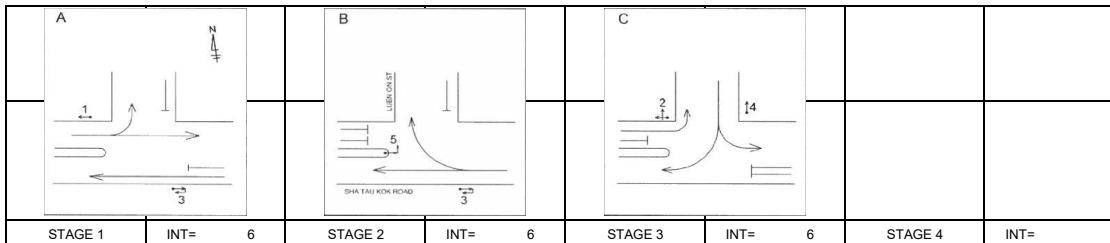

Pedestrian Phase	Width (m)	Green Time Required (s)			Green Time Provided (s)			Check
		SG	Delay	FG	SG	Delay	FG	

Move-ment	Stage	Lane Width m.	Phase	No. of lane	Radius m.	O	N	Straight-Ahead Sat. Flow	Flow			Total Flow pcu/h	Proportion of Turning Vehicles	Sat. Flow pcu/h	Uphill Gradient %	Short lane Effect pcu/h	Revised Sat. Flow pcu/h	y	Greater y	L sec	g (required) sec	g (input) sec	Degree of Saturation X	Queuing Length m.
									Left pcu/h	Straight pcu/h	Right pcu/h													
A1	1,3	3.50	2	1	15		N	1965	200			200	1.00	1786			1786	0.112		15	16	52	0.195	13
A2	1	3.50	1	2				4210		905		905	0.00	4210			4210	0.215	0.215	30	30	0.645	45	
B1	1,2	3.10	3	1			N	1925		470		470	0.00	1925			1925	0.244		34	64	0.341	20	
B1	1,2	3.10	3	1				2065		505		505	0.00	2065			2065	0.245		34	64	0.342	22	
B2	2	3.10	5	1	20			2065			405	405	1.00	1921			1921	0.211	0.211	29	29	0.645	41	
C1	3	3.40	4	1	10		N	1955	189			189	1.00	1700			1700	0.111	0.111	16	16	0.643	23	
C1,C2	3	3.40	4	1	12.5			2095	166		42	208	1.00	1871			1871	0.111		16	16	0.643	26	
C2	3	3.40	4	1	10			2095			203	203	1.00	1822			1822	0.111		16	16	0.645	25	

NOTE : 'O' - OPPOSING TRAFFIC

N - NEAR SIDE LANE

SG - STEADY GREEN

FG - FLASHING GREEN

PEDESTRIAN WALKING SPEED FOR SG(FG) = 1.2(0.9)m/s

QUEUING LENGTH = AVERAGE QUEUE * 6m

J19 - Sha Tau Kok Road / Luen On Street

J19_2031_DES_AM

PROJECT NO: 287082

Junction No. J19

DATE : 16/12/2024

FILENAME :

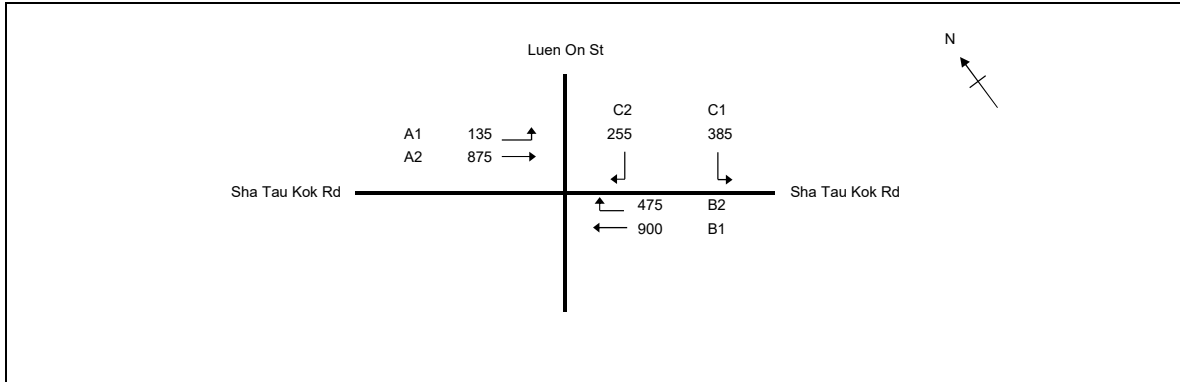

No. of stages per cycle	N = 3
No. of stage using for calculation	N = 3
Cycle time	C = 90 sec
Sum(y)	Y = 0.574
Loss time	L = 15 sec
Total Flow	= 3025 pcu
Co	= (1.5*L+5)/(1-Y) = 64.5 sec
Cm	= L/(1-Y) = 35.2 sec
Yult	= 0.788
R.C.ult	= (Yult-Y)/Y*100% = 37.2 %
Cp	= 0.9*L/(0.9-Y) = 41.4 sec
Ymax	= 1-L/C = 0.833
R.C.(C)	= (0.9*Ymax-Y)/Y*100% = 30 %

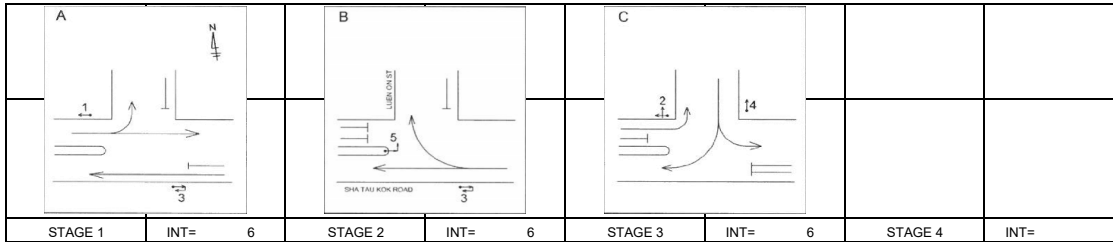

Pedestrian Phase	Width (m)	Green Time Required (s)			Green Time Provided (s)			Check
		SG	Delay	FG	SG	Delay	FG	

Move-ment	Stage	Lane Width m.	Phase	No. of lane	Radius m.	O	N	Straight-Ahead Sat. Flow	Flow			Total Flow pcu/h	Proportion of Turning Vehicles	Sat. Flow pcu/h	Uphill Gradient %	Short lane Effect pcu/h	Revised Sat. Flow pcu/h	y	Greater y	L sec	g (required) sec	g (input) sec	Degree of Saturation X	Queuing Length m.
									Left pcu/h	Straight pcu/h	Right pcu/h													
A1	1,3	3.50	2	1	15		N	1965	135			135	1.00	1786			1786	0.076		15	10	49	0.140	9
A2	1	3.50	1	2				4210		875		875	0.00	4210			4210	0.208	0.208	27	27	0.689	46	
B1	1,2	3.10	3	1			N	1925		434		434	0.00	1925			1925	0.225		29	64	0.315	18	
B1	1,2	3.10	3	1				2065		466		466	0.00	2065			2065	0.226		29	64	0.315	20	
B2	2	3.10	5	1	20			2065			475	475	1.00	1921			1921	0.247	0.247	32	32	0.689	46	
C1	3	3.40	4	1	10		N	1955		202		202	1.00	1700			1700	0.119	0.119	16	16	0.689	25	
C1,C2	3	3.40	4	1	12.5			2095		183		222	1.00	1871			1871	0.119		16	16	0.688	28	
C2	3	3.40	4	1	10			2095			216	216	1.00	1822			1822	0.119		15	16	0.687	27	

NOTE : 'O' - OPPOSING TRAFFIC

N - NEAR SIDE LANE

SG - STEADY GREEN

FG - FLASHING GREEN

PEDESTRIAN WALKING SPEED FOR SG(FG) = 1.2(0.9)m/s

QUEUING LENGTH = AVERAGE QUEUE * 6m

J19 - Sha Tau Kok Road / Luen On Street

J19_2031_DES_PM

PROJECT NO: 287082

Junction No. J19

DATE : 16/12/2024

FILENAME :

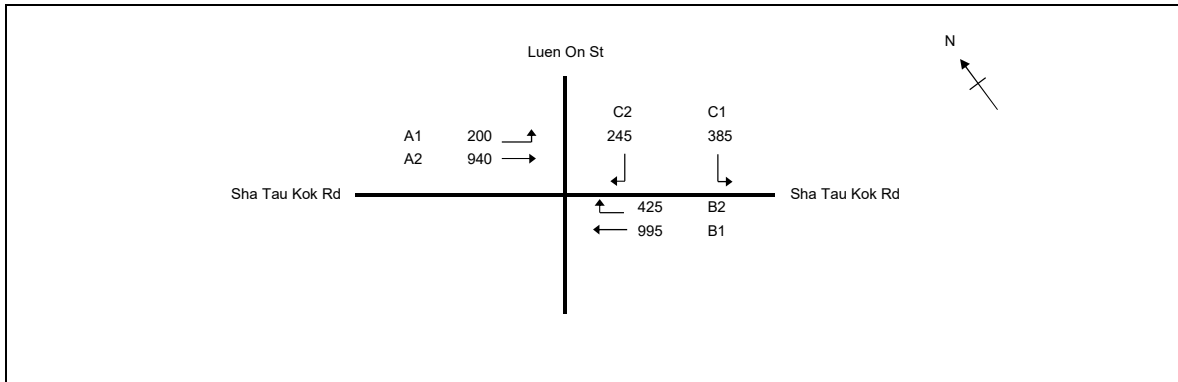

No. of stages per cycle	N = 3
No. of stage using for calculation	N = 3
Cycle time	C = 90 sec
Sum(y)	Y = 0.562
Loss time	L = 15 sec
Total Flow	= 3190 pcu
Co	= (1.5*L+5)/(1-Y) = 62.7 sec
Cm	= L/(1-Y) = 34.2 sec
Yult	= 0.788
R.C.ult	= (Yult-Y)/Y*100% = 40.2 %
Cp	= 0.9*L/(0.9-Y) = 39.9 sec
Ymax	= 1-L/C = 0.833
R.C.(C)	= (0.9*Ymax-Y)/Y*100% = 33 %

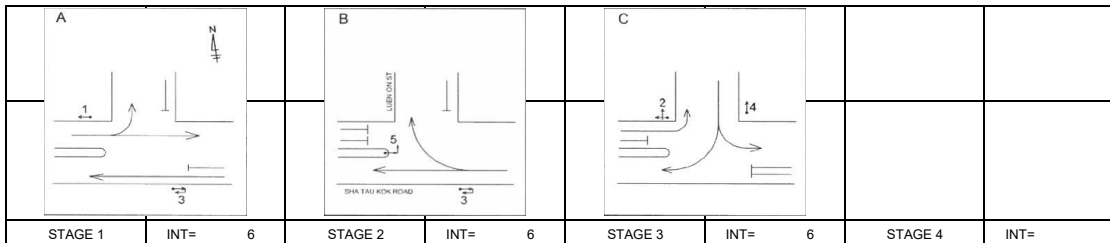

Pedestrian Phase	Width (m)	Green Time Required (s)			Green Time Provided (s)			Check
		SG	Delay	FG	SG	Delay	FG	

Move-ment	Stage	Lane Width m.	Phase	No. of lane	Radius m.	O	N	Straight-Ahead Sat. Flow	Flow			Total Flow pcu/h	Proportion of Turning Vehicles	Sat. Flow pcu/h	Uphill Gradient %	Short lane Effect pcu/h	Revised Sat. Flow pcu/h	y	Greater y	L sec	g (required) sec	g (input) sec	Degree of Saturation X	Queuing Length m.
									Left pcu/h	Straight pcu/h	Right pcu/h													
A1	1,3	3.50	2	1	15		N	1965	200			200	1.00	1786			1786	0.112		15	15	51	0.196	13
A2	1	3.50	1	2				4210		940		940	0.00	4210			4210	0.223	0.223	30	30	64	0.674	47
B1	1,2	3.10	3	1			N	1925		480		480	0.00	1925			1925	0.249		33	64	0.349	21	
B1	1,2	3.10	3	1				2065		515		515	0.00	2065			2065	0.249		33	64	0.349	22	
B2	2	3.10	5	1	20			2065			425	425	1.00	1921			1921	0.221	0.221	30	30	64	0.674	43
C1	3	3.40	4	1	10		N	1955		199		199	1.00	1700			1700	0.117	0.117	16	16	16	0.674	25
C1,C2	3	3.40	4	1	12.5			2095		186		218	1.00	1871			1871	0.117		16	16	16	0.671	27
C2	3	3.40	4	1	10			2095			213	213	1.00	1822			1822	0.117		16	16	16	0.673	26

NOTE : 'O' - OPPOSING TRAFFIC

N - NEAR SIDE LANE

SG - STEADY GREEN

FG - FLASHING GREEN

PEDESTRIAN WALKING SPEED FOR SG(FG) = 1.2(0.9)m/s

QUEUING LENGTH = AVERAGE QUEUE * 6m

J20 - Sha Tau Kok Road / Fan Leng Lau Road / Lok Yip Road

J20_2023_EXT_AM

PROJECT NO: 287082

Junction No. J20

DATE: 16-Dec-24

FILENAME:

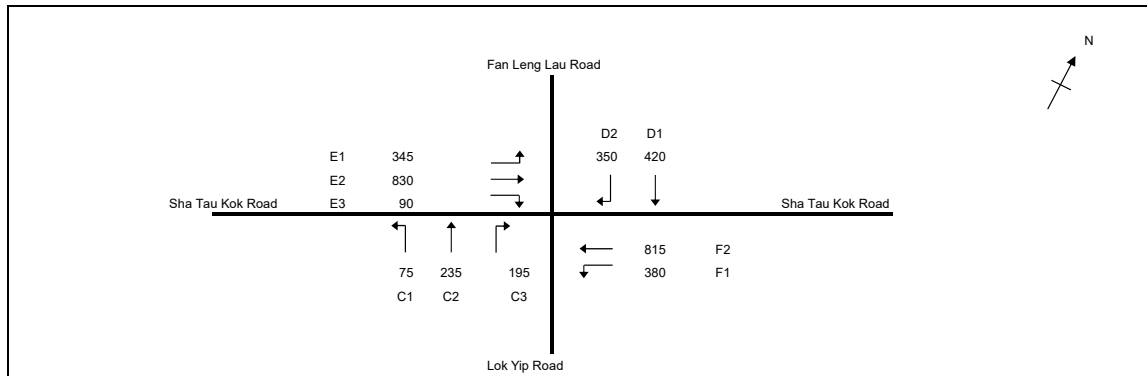

No. of stages per cycle	N = 4
No. of stage using for calculation	N = 4
Cycle time	C = 120 sec
Sum(y)	Y = 0.549
Loss time	L = 23 sec
Total Flow	= 3735 pcu
Co	= (1.5*L+5)/(1-Y) = 87.6 sec
Cm	= L/(1-Y) = 51.0 sec
Yult	= 0.728
R.C.ult	= (Yult-Y)/Y*100% = 32.5 %
Cp	= 0.9*L/(0.9-Y) = 59.0 sec
Ymax	= 1-L/C = 0.808
R.C.(C)	= (0.9*Ymax-Y)/Y*100% = 33 %

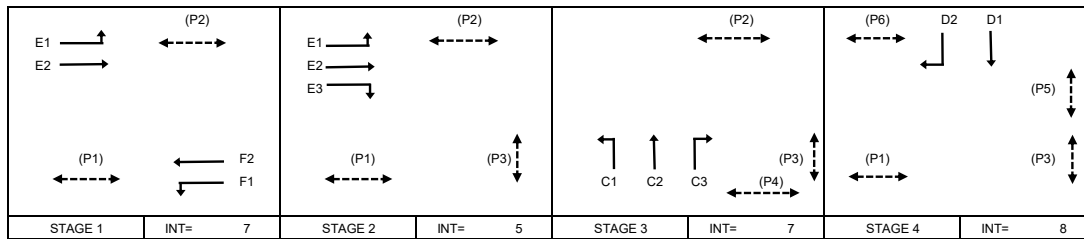

Pedestrian Phase	Width (m)	Green Time Required (s)			Green Time Provided (s)			Check
		SG	Delay	FG	SG	Delay	FG	
P1	10	6	3	11	77	3	11	OK
P2	7	6	2	8	67	2	8	OK
P3	13.5	6	2	15	69	2	15	OK
P4	7.5	6	8	8	13	8	8	OK
P5	8.5	6	9	9	25	9	9	OK
P6	9	6	6	10	27	6	10	OK

Move-ment	Stage	Lane Width m.	Phase	No. of lane	Radius m.	O	N	Straight-Ahead Sat. Flow	Flow			Total Flow pcu/h	Proportion of Turning Vehicles	Sat. Flow pcu/h	Uphill Gradient %	Short lane Effect pcu/h	Revised Sat. Flow pcu/h	y	Greater y	L sec	g (required) sec	g (input) sec	Degree of Saturation X	Queuing Length m.
									Left pcu/h	Straight pcu/h	Right pcu/h													
F1	1	3.10	F	1	10		N	1925	261		261	1.00	1674			1674	0.156	0.156	23	28	28	0.677	40	
F1,F2	1	3.10	F	1	10		N	2065	119	186	305	0.39	1951			1951	0.156			28	28	0.679	47	
F2	1	3.10	F	1				2065		306	306	0.00	2065			1962	0.156			28	28	0.677	47	
F2	1	3.10	F	1				2065		323	323	0.00	2065			2065	0.156			28	28	0.679	50	
E1	1,2	3.00	E	1	10		N	1915	339		339	1.00	1665			1665	0.204			36	44	0.556	43	
E1,E2	1,2	3.00	E	1	10		N	2055	6	412	418	0.01	2051			2051	0.204			36	44	0.556	53	
E2	1,2	3.00	E	1				2055		418	418	0.00	2055			2055	0.203			36	44	0.555	53	
E3	2	3.00	E	1	20			2055		90	90	1.00	1912			1912	0.047	0.047		8	8	0.679	17	
C1,C2	3	3.50	C	1	15		N	1965	75	172	247	0.30	1907			1907	0.130	0.130		23	23	0.679	40	
C2,C3	3	3.50	C	1	20			2105	63	195	258	0.76	1992			1992	0.130			23	23	0.679	42	
D1,D2	4	3.30	D	1	20		N	1945		420	420	0.00	1945			1945	0.216	0.216		38	38	0.679	57	
D2	4	3.30	D	1	20			2085		350	350	1.00	1940			1940	0.180			32	38	0.568	48	

NOTE: 'O' - OPPOSING TRAFFIC N - NEAR SIDE LANE SG - STEADY GREEN FG - FLASHING GREEN PEDESTRIAN WALKING SPEED FOR SG(FG) = 1.2(0.9)m/s QUEUING LENGTH = AVERAGE QUEUE * 6m

J20 - Sha Tau Kok Road / Fan Leng Lau Road / Lok Yip Road

J20_2023_EXT_PM

PROJECT NO: 287082

Junction No. J20

DATE: 16-Dec-24

FILENAME:

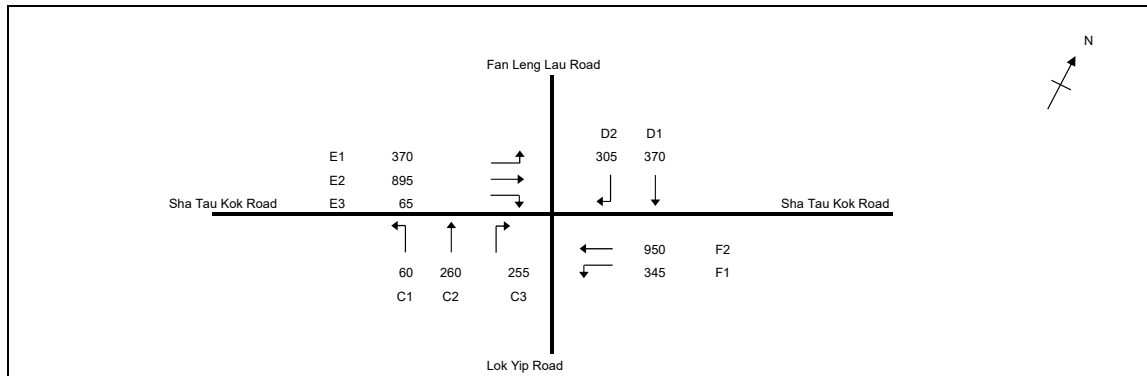

No. of stages per cycle	N = 4
No. of stage using for calculation	N = 4
Cycle time	C = 120 sec
Sum(y)	Y = 0.542
Loss time	L = 23 sec
Total Flow	= 3875 pcu
Co	= (1.5*L+5)/(1-Y) = 86.3 sec
Cm	= L/(1-Y) = 50.2 sec
Yult	= 0.728
R.C.ult	= (Yult-Y)/Y*100% = 34.2 %
Cp	= 0.9*L/(0.9-Y) = 57.9 sec
Ymax	= 1-L/C = 0.808
R.C.(C)	= (0.9*Ymax-Y)/Y*100% = 34 %

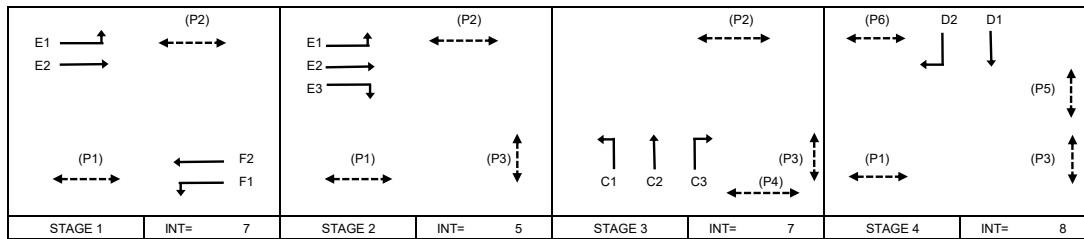

Pedestrian Phase	Width (m)	Green Time Required (s)			Green Time Provided (s)			Check
		SG	Delay	FG	SG	Delay	FG	
P1	10	6	3	11	74	3	11	OK
P2	7	6	2	8	71	2	8	OK
P3	13.5	6	2	15	67	2	15	OK
P4	7.5	6	8	8	16	8	8	OK
P5	8.5	6	9	9	21	9	9	OK
P6	9	6	6	10	23	6	10	OK

Move-ment	Stage	Lane Width m.	Phase	No. of lane	Radius m.	O	N	Straight-Ahead Sat. Flow	Flow			Total Flow pcu/h	Proportion of Turning Vehicles	Sat. Flow pcu/h	Uphill Gradient %	Short lane Effect pcu/h	Revised Sat. Flow pcu/h	y	Greater y	L sec	g (required) sec	g (input) sec	Degree of Saturation X	Queuing Length m.
									Left pcu/h	Straight pcu/h	Right pcu/h													
F1	1	3.10	F	1	10		N	1925	285		285	1.00	1674			1674	0.170	0.170	23	30	30	0.670	43	
F1,F2	1	3.10	F	1	10		N	2065	60	282	342	0.18	2012			2012	0.170			30	30	0.669	51	
F2	1	3.10	F	1				2065		316	316	0.00	2065			1859	0.170			30	30	0.669	47	
F2	1	3.10	F	1				2065		352	352	0.00	2065			2065	0.170			30	30	0.671	53	
E1	1,2	3.00	E	1	10		N	1915	365		365	1.00	1665			1665	0.219			39	45	0.590	46	
E1,E2	1,2	3.00	E	1	10		N	2055	5	445	450	0.01	2052			2052	0.219			39	45	0.591	57	
E2	1,2	3.00	E	1				2055		450	450	0.00	2055			2055	0.219			39	45	0.590	57	
E3	2	3.00	E	1	20			2055		65	65	1.00	1912			1912	0.034	0.034	6	6	0.671	12		
C1,C2	3	3.50	C	1	15		N	1965	60	224	284	0.21	1924			1924	0.148	0.148	26	26	0.671	44		
C2,C3	3	3.50	C	1	20			2105	36	255	291	0.88	1975			1975	0.147			26	26	0.670	45	
D1,D2	4	3.30	D	1	20		N	1945		370	370	0.00	1945			1945	0.190	0.190	34	34	0.671	53		
D2	4	3.30	D	1	20			2085		305	305	1.00	1940			1940	0.157			28	34	0.555	44	

NOTE: 'O' - OPPOSING TRAFFIC N - NEAR SIDE LANE SG - STEADY GREEN FG - FLASHING GREEN PEDESTRIAN WALKING SPEED FOR SG(FG) = 1.2(0.9)m/s QUEUING LENGTH = AVERAGE QUEUE * 6m

J20 - Sha Tau Kok Road / Fan Leng Lau Road / Lok Yip Road

J20_2031_REF_AM

PROJECT NO: 287082

Junction No. J20

DATE: 16-Dec-24

FILENAME:

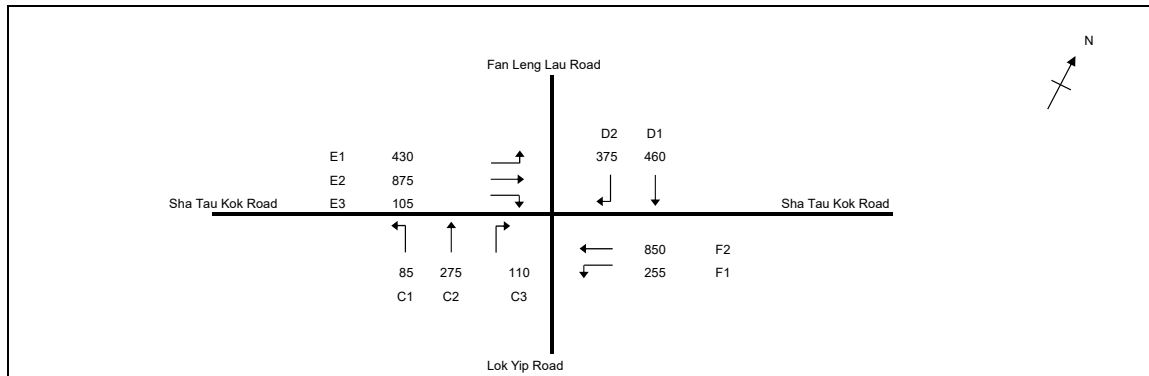

No. of stages per cycle	N = 4
No. of stage using for calculation	N = 4
Cycle time	C = 120 sec
Sum(y)	Y = 0.552
Loss time	L = 23 sec
Total Flow	= 3820 pcu
Co	= (1.5*L+5)/(1-Y) = 88.2 sec
Cm	= L/(1-Y) = 51.4 sec
Yult	= 0.728
R.C.ult	= (Yult-Y)/Y*100% = 31.7 %
Cp	= 0.9*L/(0.9-Y) = 59.5 sec
Ymax	= 1-L/C = 0.808
R.C.(C)	= (0.9*Ymax-Y)/Y*100% = 31 %

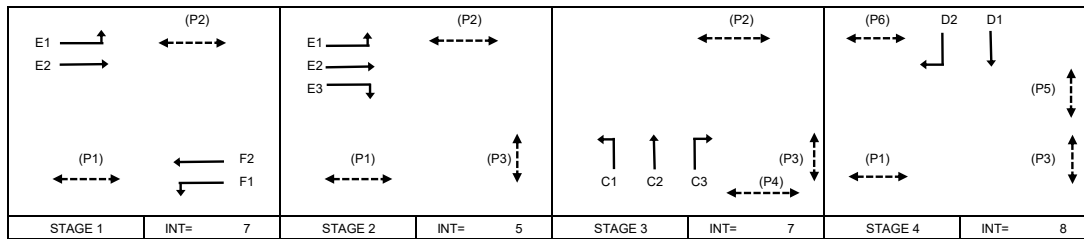

Pedestrian Phase	Width (m)	Green Time Required (s)			Green Time Provided (s)			Check
		SG	Delay	FG	SG	Delay	FG	
P1	10	6	3	11	79	3	11	OK
P2	7	6	2	8	63	2	8	OK
P3	13.5	6	2	15	72	2	15	OK
P4	7.5	6	8	8	11	8	8	OK
P5	8.5	6	9	9	29	9	9	OK
P6	9	6	6	10	31	6	10	OK

Move-ment	Stage	Lane Width m.	Phase	No. of lane	Radius m.	O	N	Straight-Ahead Sat. Flow	Flow			Total Flow pcu/h	Proportion of Turning Vehicles	Sat. Flow pcu/h	Uphill Gradient %	Short lane Effect pcu/h	Revised Sat. Flow pcu/h	y	Greater y	L sec	g (required) sec	g (input) sec	Degree of Saturation X	Queuing Length m.
									Left pcu/h	Straight pcu/h	Right pcu/h													
F1	1	3.10	F	1	10		N	1925	236		236	1.00	1674			1674	0.141	0.141	23	25	25	0.683	37	
F1,F2	1	3.10	F	1	10		N	2065	19	269	288	0.07	2045			2045	0.141			25	25	0.683	46	
F2	1	3.10	F	1				2065		291	291	0.00	2065			2065	0.141			25	25	0.683	46	
F2	1	3.10	F	1				2065		290	290	0.00	2065			2065	0.140			25	25	0.681	46	
E1	1,2	3.00	E	1	10		N	1915	379		379	1.00	1665			1665	0.228			40	42	0.644	49	
E1,E2	1,2	3.00	E	1	10		N	2055	51	408	459	0.11	2021			2021	0.227			40	42	0.643	59	
E2	1,2	3.00	E	1				2055		467	467	0.00	2055			2055	0.227			40	42	0.643	60	
E3	2	3.00	E	1	20			2055		105	105	1.00	1912			1912	0.055	0.055	10	10	0.683	19		
C1,C2	3	3.50	C	1	15		N	1965	85	142	227	0.37	1894			1894	0.120	0.120	21	21	0.683	37		
C2,C3	3	3.50	C	1	20			2105		133	243	0.45	2036			2036	0.119			21	21	0.680	40	
D1,D2	4	3.30	D	1	20		N	1945		460	460	0.00	1945			1945	0.237	0.237	42	42	0.683	60		
D2	4	3.30	D	1	20			2085		375	375	1.00	1940			1940	0.193			34	42	0.559	49	

NOTE: 'O' - OPPOSING TRAFFIC 'N' - NEAR SIDE LANE SG - STEADY GREEN FG - FLASHING GREEN PEDESTRIAN WALKING SPEED FOR SG(FG) = 1.2(0.9)m/s QUEUING LENGTH = AVERAGE QUEUE * 6m

J20 - Sha Tau Kok Road / Fan Leng Lau Road / Lok Yip Road

J20_2031_REF_PM

PROJECT NO: 287082

Junction No. J20

DATE: 16-Dec-24

FILENAME:

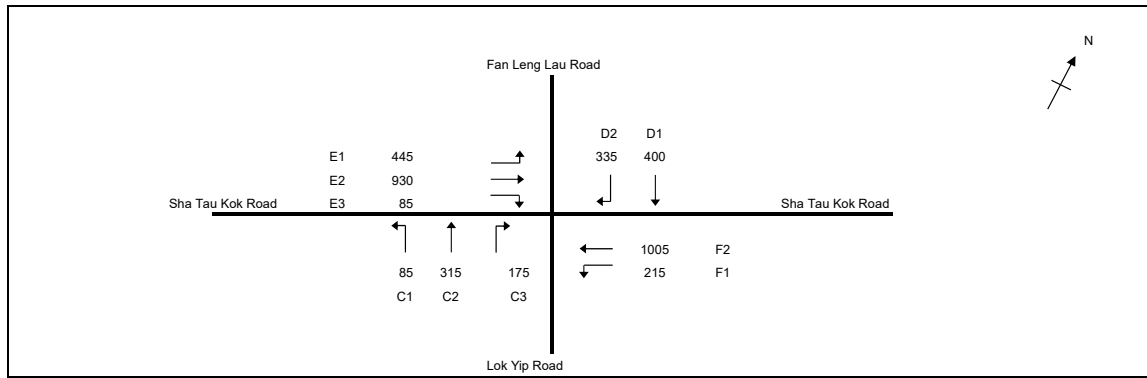

No. of stages per cycle	N = 4
No. of stage using for calculation	N = 4
Cycle time	C = 120 sec
Sum(y)	Y = 0.565
Loss time	L = 23 sec
Total Flow	= 3990 pcu
Co	= (1.5*L+5)/(1-Y) = 90.8 sec
Cm	= L/(1-Y) = 52.9 sec
Yult	= 0.728
R.C.ult	= (Yult-Y)/Y*100% = 28.8 %
Cp	= 0.9*L/(0.9-Y) = 61.8 sec
Ymax	= 1-L/C = 0.808
R.C.(C)	= (0.9*Ymax-Y)/Y*100% = 28 %

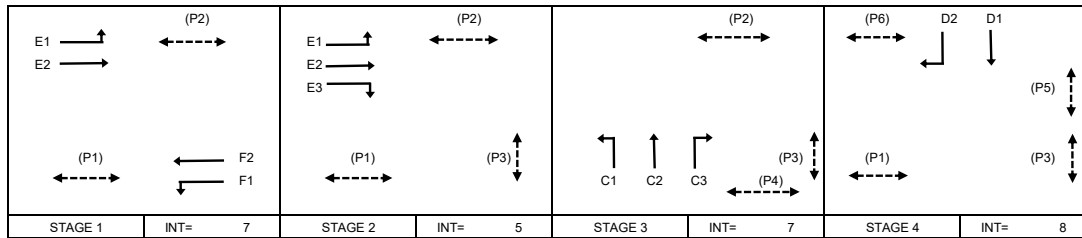

Pedestrian Phase	Width (m)	Green Time Required (s)			Green Time Provided (s)			Check
		SG	Delay	FG	SG	Delay	FG	
P1	10	6	3	11	75	3	11	OK
P2	7	6	2	8	70	2	8	OK
P3	13.5	6	2	15	68	2	15	OK
P4	7.5	6	8	8	15	8	8	OK
P5	8.5	6	9	9	22	9	9	OK
P6	9	6	6	10	24	6	10	OK

Move-ment	Stage	Lane Width m.	Phase	No. of lane	Radius m.	O	N	Straight-Ahead Sat. Flow	Flow			Total Flow pcu/h	Proportion of Turning Vehicles	Sat. Flow pcu/h	Uphill Gradient %	Short lane Effect pcu/h	Revised Sat. Flow pcu/h	y	Greater y	L sec	g (required) sec	g (input) sec	Degree of Saturation X	Queuing Length m.
									Left pcu/h	Straight pcu/h	Right pcu/h													
F1	1	3.10	F	1	10		N	1925	215		215	1.00	1674			1674	0.128	0.168	23	22	29	0.534	33	
F1,F2	1	3.10	F	1	10		N	2065	0	347	347	0.00	2065			2065	0.168			29	29	0.699	53	
F2	1	3.10	F	1				2065		311	311	0.00	2065			1859	0.167			29	29	0.696	47	
F2	1	3.10	F	1				2065		347	347	0.00	2065			2065	0.168			29	29	0.699	53	
E1	1,2	3.00	E	1	10		N	1915	405		405	1.00	1665			1665	0.243			42	44	0.656	51	
E1,E2	1,2	3.00	E	1	10		N	2055	40	455	495	0.08	2030			2030	0.244			42	44	0.658	62	
E2	1,2	3.00	E	1				2055		475	475	0.00	2055			1952	0.243			42	44	0.656	60	
E3	2	3.00	E	1	20			2055			85	1.00	1912			1912	0.044	0.044		8	8	0.699	16	
C1,C2	3	3.50	C	1	15		N	1965	85	195	280	0.30	1907			1907	0.147	0.147		25	25	0.699	44	
C2,C3	3	3.50	C	1	20			2105		120	175	0.59	2015			2015	0.146			25	25	0.697	47	
D1,D2	4	3.30	D	1	20		N	1945		400	400	0.00	1945			1945	0.206	0.206		35	35	0.699	56	
D2	4	3.30	D	1	20			2085			335	1.00	1940			1940	0.173			30	35	0.587	47	

NOTE: 'O' - OPPOSING TRAFFIC N - NEAR SIDE LANE SG - STEADY GREEN FG - FLASHING GREEN PEDESTRIAN WALKING SPEED FOR SG(FG) = 1.2(0.9)m/s QUEUING LENGTH = AVERAGE QUEUE * 6m

J20 - Sha Tau Kok Road / Fan Leng Lau Road / Lok Yip Road

J20_2031_DES_AM

PROJECT NO: 287082

Junction No. J20

DATE: 16-Dec-24

FILENAME:

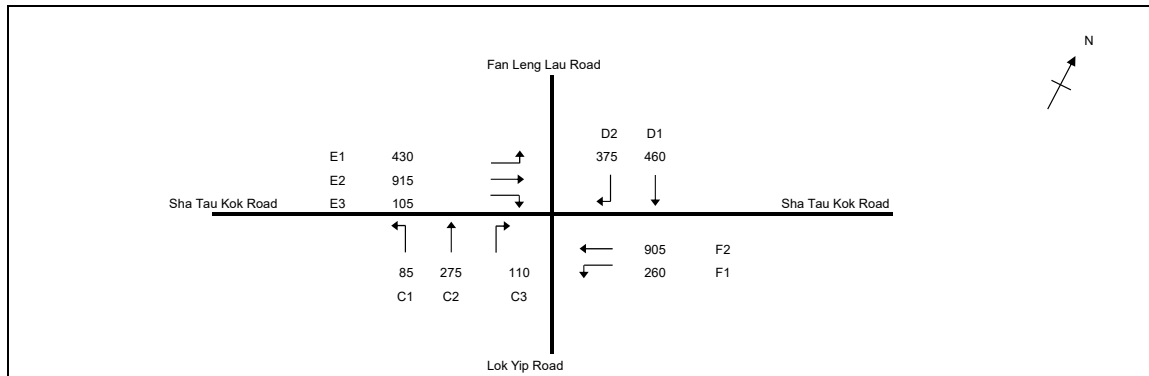

No. of stages per cycle	N = 4
No. of stage using for calculation	N = 4
Cycle time	C = 120 sec
Sum(y)	Y = 0.562
Loss time	L = 23 sec
Total Flow	= 3920 pcu
Co	= (1.5*L+5)/(1-Y) = 90.1 sec
Cm	= L/(1-Y) = 52.5 sec
Yult	= 0.728
R.C.ult	= (Yult-Y)*100% = 29.5 %
Cp	= 0.9*L/(0.9-Y) = 61.2 sec
Ymax	= 1-L/C = 0.808
R.C.(C)	= (0.9*Ymax-Y)*100% = 29 %

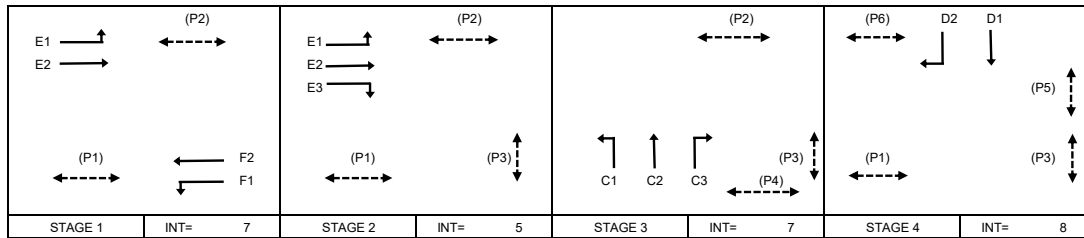

Pedestrian Phase	Width (m)	Green Time Required (s)			Green Time Provided (s)			Check
		SG	Delay	FG	SG	Delay	FG	
P1	10	6	3	11	79	3	11	OK
P2	7	6	2	8	64	2	8	OK
P3	13.5	6	2	15	71	2	15	OK
P4	7.5	6	8	8	11	8	8	OK
P5	8.5	6	9	9	28	9	9	OK
P6	9	6	6	10	30	6	10	OK

Move-ment	Stage	Lane Width m.	Phase	No. of lane	Radius m.	O	N	Straight-Ahead Sat. Flow	Flow			Total Flow pcu/h	Proportion of Turning Vehicles	Sat. Flow pcu/h	Uphill Gradient %	Short lane Effect pcu/h	Revised Sat. Flow pcu/h	y	Greater y	L sec	g (required) sec	g (input) sec	Degree of Saturation X	Queuing Length m.
									Left pcu/h	Straight pcu/h	Right pcu/h													
F1	1	3.10	F	1	10		N	1925	251		251	1.00	1674			1674	0.150	0.150	23	26	26	0.693	39	
F1,F2	1	3.10	F	1	10		N	2065	9	300	309	0.03	2056			2056	0.150			26	26	0.694	48	
F2	1	3.10	F	1				2065		295	295	0.00	2065			1962	0.150			26	26	0.695	46	
F2	1	3.10	F	1				2065		310	310	0.00	2065			2065	0.150			26	26	0.694	49	
E1	1,2	3.00	E	1	10		N	1915	389		389	1.00	1665			1665	0.234			40	43	0.645	50	
E1,E2	1,2	3.00	E	1	10		N	2055	41	434	475	0.09	2029			2029	0.234			40	43	0.647	61	
E2	1,2	3.00	E	1				2055		481	481	0.00	2055			2055	0.234			40	43	0.646	61	
E3	2	3.00	E	1	20			2055		105	105	1.00	1912			1912	0.055	0.055		9	9	0.695	19	
C1,C2	3	3.50	C	1	15		N	1965	85	142	227	0.37	1894			1894	0.120	0.120		21	21	0.695	38	
C2,C3	3	3.50	C	1	20			2105		133	243	0.45	2036			2036	0.119			21	21	0.692	40	
D1,D2	4	3.30	D	1	20		N	1945		460	460	0.00	1945			1945	0.237	0.237		41	41	0.695	61	
D2	4	3.30	D	1	20			2085		375	375	1.00	1940			1940	0.193			33	41	0.568	49	

NOTE: 'O' - OPPOSING TRAFFIC 'N' - NEAR SIDE LANE SG - STEADY GREEN FG - FLASHING GREEN PEDESTRIAN WALKING SPEED FOR SG(FG) = 1.2(0.9)m/s QUEUING LENGTH = AVERAGE QUEUE * 6m

J20 - Sha Tau Kok Road / Fan Leng Lau Road / Lok Yip Road

J20_2031_DES_PM

PROJECT NO: 287082

Junction No. J20

DATE: 16-Dec-24

FILENAME:

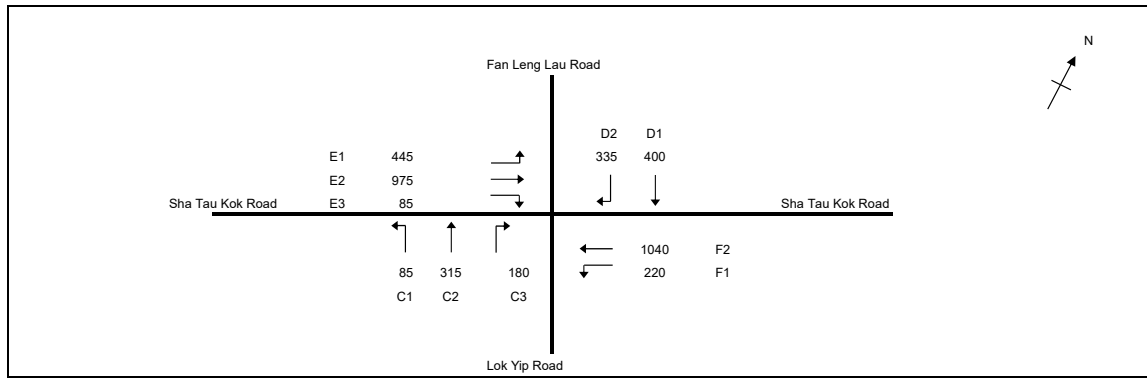

No. of stages per cycle	N = 4
No. of stage using for calculation	N = 4
Cycle time	C = 120 sec
Sum(y)	Y = 0.575
Loss time	L = 23 sec
Total Flow	= 4080 pcu
Co	= (1.5*L+5)/(1-Y) = 92.9 sec
Cm	= L/(1-Y) = 54.1 sec
Yult	= 0.728
R.C.ult	= (Yult-Y)/Y*100% = 26.6 %
Cp	= 0.9*L/(0.9-Y) = 63.7 sec
Ymax	= 1-L/C = 0.808
R.C.(C)	= (0.9*Ymax-Y)/Y*100% = 26 %

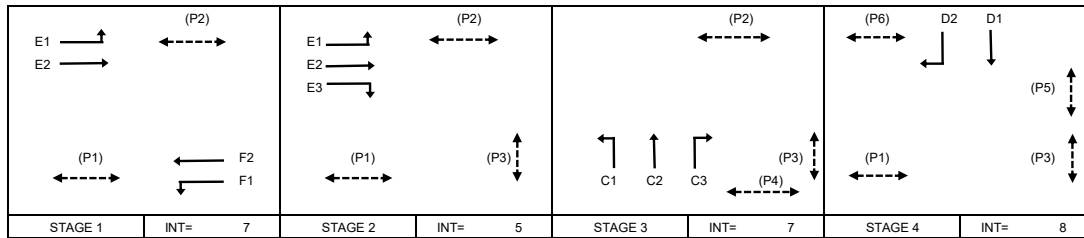

Pedestrian Phase	Width (m)	Green Time Required (s)			Green Time Provided (s)			Check
		SG	Delay	FG	SG	Delay	FG	
P1	10	6	3	11	75	3	11	OK
P2	7	6	2	8	70	2	8	OK
P3	13.5	6	2	15	67	2	15	OK
P4	7.5	6	8	8	15	8	8	OK
P5	8.5	6	9	9	22	9	9	OK
P6	9	6	6	10	24	6	10	OK

Move-ment	Stage	Lane Width m.	Phase	No. of lane	Radius m.	O	N	Straight-Ahead Sat. Flow	Flow			Total Flow pcu/h	Proportion of Turning Vehicles	Sat. Flow pcu/h	Uphill Gradient %	Short lane Effect pcu/h	Revised Sat. Flow pcu/h	y	Greater y	L sec	g (required) sec	g (input) sec	Degree of Saturation X	Queuing Length m.
									Left pcu/h	Straight pcu/h	Right pcu/h													
F1	1	3.10	F	1	10		N	1925	220		220	1.00	1674			1674	0.131	0.177	23	22	30	0.529	33	
F1,F2	1	3.10	F	1	10		N	2065	0	365	365	0.00	2065			2065	0.177			30	30	0.711	55	
F2	1	3.10	F	1				2065		310	310	0.00	2065			1755	0.177			30	30	0.711	47	
F2	1	3.10	F	1				2065		365	365	0.00	2065			2065	0.177			30	30	0.711	55	
E1	1,2	3.00	E	1	10		N	1915	425		425	1.00	1665			1665	0.255			43	45	0.676	53	
E1,E2	1,2	3.00	E	1	10		N	2055	20	502	522	0.04	2043			2043	0.255			43	45	0.676	65	
E2	1,2	3.00	E	1				2055		473	473	0.00	2055			1850	0.256			43	45	0.677	59	
E3	2	3.00	E	1	20			2055			85	1.00	1912			1912	0.044	0.044		8	8	0.711	16	
C1,C2	3	3.50	C	1	15		N	1965	85	197	282	0.30	1908			1908	0.148	0.148		25	25	0.710	45	
C2,C3	3	3.50	C	1	20			2105		118	180	0.60	2014			2014	0.148			25	25	0.711	47	
D1,D2	4	3.30	D	1	20		N	1945		400	400	0.00	1945			1945	0.206	0.206		35	35	0.711	57	
D2	4	3.30	D	1	20			2085			335	1.00	1940			1940	0.173			29	35	0.597	48	

NOTE: 'O' - OPPOSING TRAFFIC N - NEAR SIDE LANE SG - STEADY GREEN FG - FLASHING GREEN PEDESTRIAN WALKING SPEED FOR SG(FG) = 1.2(0.9)m/s QUEUING LENGTH = AVERAGE QUEUE * 6m

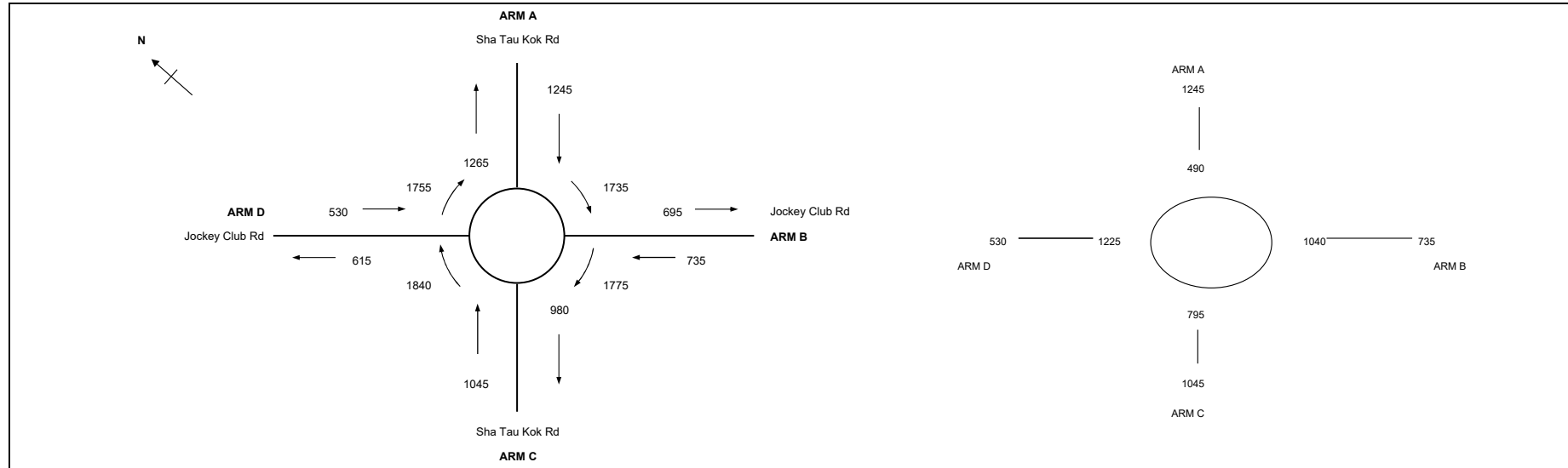

ARM	A	B	C	D	
INPUT PARAMETERS:					
V = Approach half width (m)	7.30	7.30	7.30	7.30	
E = Entry width (m)	9.00	8.00	9.00	8.00	
L = Effective length of flare (m)	10	10	15	10	
R = Entry radius (m)	30	35	50	30	
D = Inscribed circle diameter (m)	65	65	65	65	
A = Entry angle (degree)	20	10	15	25	
Q = Entry flow (pcu/h)	1245	735	1045	530	
Qc = Circulating flow across entry (pcu/h)	490	1040	795	1225	
OUTPUT PARAMETERS:					
S = Sharpness of flare = 1.6(E-V)/L	0.27	0.11	0.18	0.11	
K = $1 - 0.00347(A-30) - 0.978(1/R - 0.05)$	1.05	1.09	1.08	1.03	
X2 = $V + ((E-V)/(1+2S))$	8.40	7.87	8.55	7.87	
M = $EXP((D-60)/10)$	1.65	1.65	1.65	1.65	
F = $303 \times X2$	2546	2385	2590	2385	
Td = $1 + (0.5/(1+M))$	1.19	1.19	1.19	1.19	
Fc = $0.21 \times Td(1 + 0.2 \times X2)$	0.67	0.64	0.68	0.64	
Qe = $K(F - Fc \times Qc)$	2331	1872	2219	1652	
DFC = Design flow/Capacity = Q/Qe	0.53	0.39	0.47	0.32	
Total In Sum =				3555	PCU
DFC of Critical Approach =				0.53	

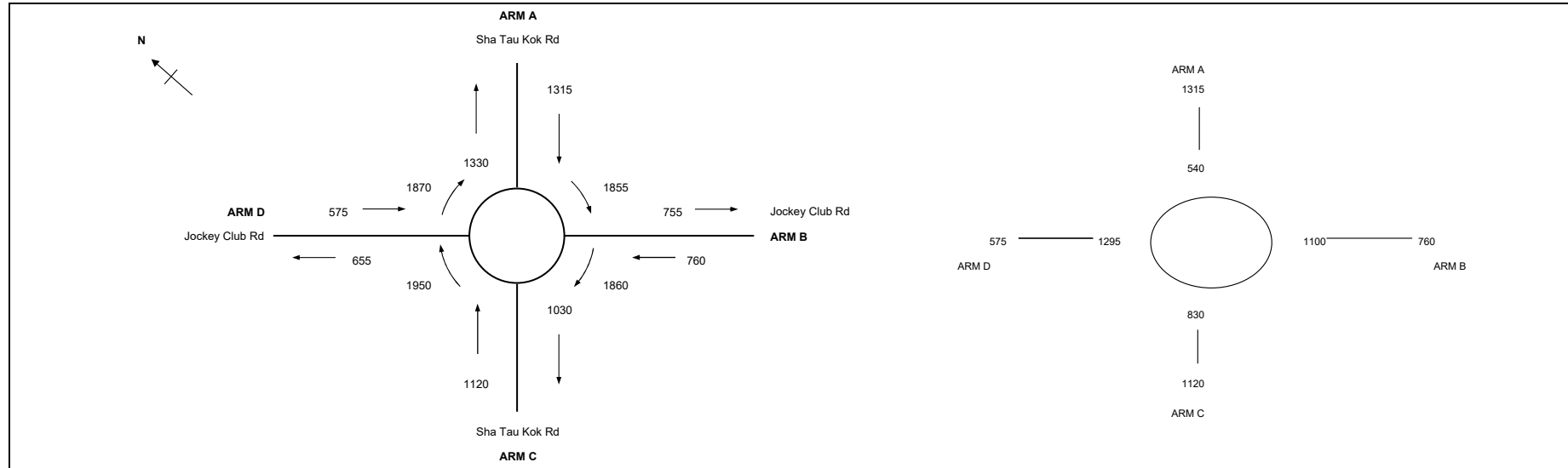

ARM	A	B	C	D
INPUT PARAMETERS:				
V = Approach half width (m)	7.30	7.30	7.30	7.30
E = Entry width (m)	9.00	8.00	9.00	8.00
L = Effective length of flare (m)	10	10	15	10
R = Entry radius (m)	30	35	50	30
D = Inscribed circle diameter (m)	65	65	65	65
A = Entry angle (degree)	20	10	15	25
Q = Entry flow (pcu/h)	1315	760	1120	575
Qc = Circulating flow across entry (pcu/h)	540	1100	830	1295
OUTPUT PARAMETERS:				
S = Sharpness of flare = 1.6(E-V)/L	0.27	0.11	0.18	0.11
K = $1 - 0.00347(A-30) - 0.978(1/R - 0.05)$	1.05	1.09	1.08	1.03
X2 = $V + ((E-V)/(1+2S))$	8.40	7.87	8.55	7.87
M = $EXP((D-60)/10)$	1.65	1.65	1.65	1.65
F = $303 * X2$	2546	2385	2590	2385
Td = $1 + (0.5/(1+M))$	1.19	1.19	1.19	1.19
Fc = $0.21 * Td * (1 + 0.2 * X2)$	0.67	0.64	0.68	0.64
Qe = $K(F * Fc * Qc)$	2296	1830	2194	1605
DFC = Design flow/Capacity = Q/Qe	0.57	0.42	0.51	0.36
Total In Sum =				3770 PCU
DFC of Critical Approach =				0.57

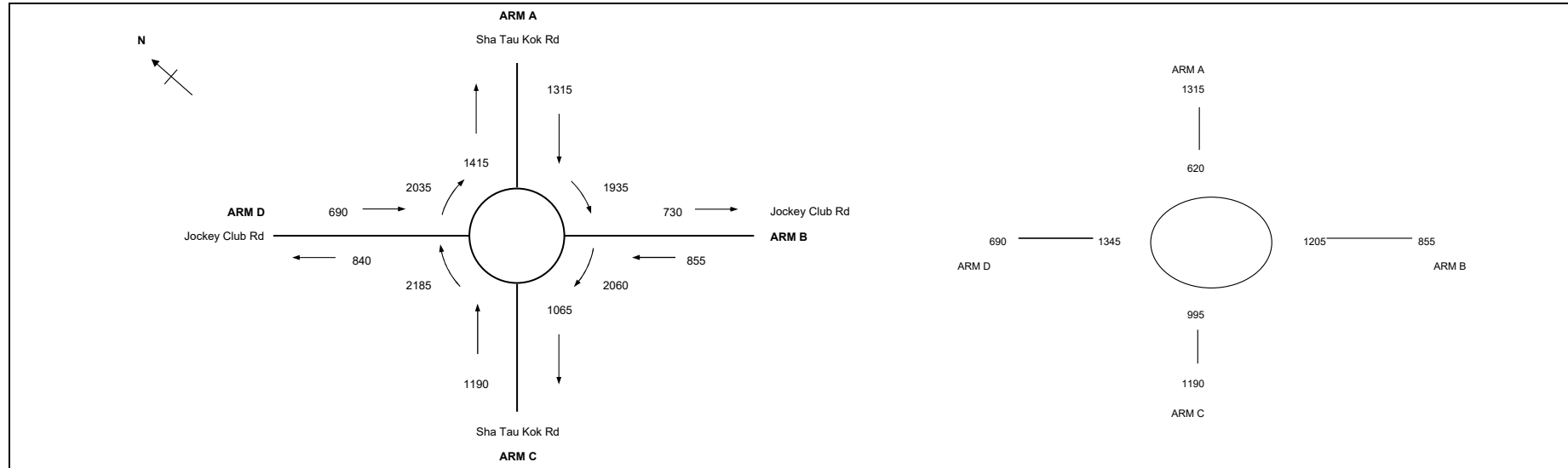

ARM	A	B	C	D
INPUT PARAMETERS:				
V = Approach half width (m)	7.30	7.30	7.30	7.30
E = Entry width (m)	9.00	8.00	9.00	8.00
L = Effective length of flare (m)	10	10	15	10
R = Entry radius (m)	30	35	50	30
D = Inscribed circle diameter (m)	65	65	65	65
A = Entry angle (degree)	20	10	15	25
Q = Entry flow (pcu/h)	1315	855	1190	690
Qc = Circulating flow across entry (pcu/h)	620	1205	995	1345
OUTPUT PARAMETERS:				
S = Sharpness of flare = 1.6(E-V)/L	0.27	0.11	0.18	0.11
K = $1 - 0.00347(A-30) - 0.978(1/R - 0.05)$	1.05	1.09	1.08	1.03
X2 = $V + ((E-V)/(1+2S))$	8.40	7.87	8.55	7.87
M = $EXP((D-60)/10)$	1.65	1.65	1.65	1.65
F = $303 * X2$	2546	2385	2590	2385
Td = $1 + (0.5/(1+M))$	1.19	1.19	1.19	1.19
Fc = $0.21 * Td(1 + 0.2 * X2)$	0.67	0.64	0.68	0.64
Qe = $K(F - Fc * Qc)$	2239	1756	2073	1572
DFC = Design flow/Capacity = Q/Qe	0.59	0.49	0.58	0.44
Total In Sum = 4050 PCU				
DFC of Critical Approach = 0.59				

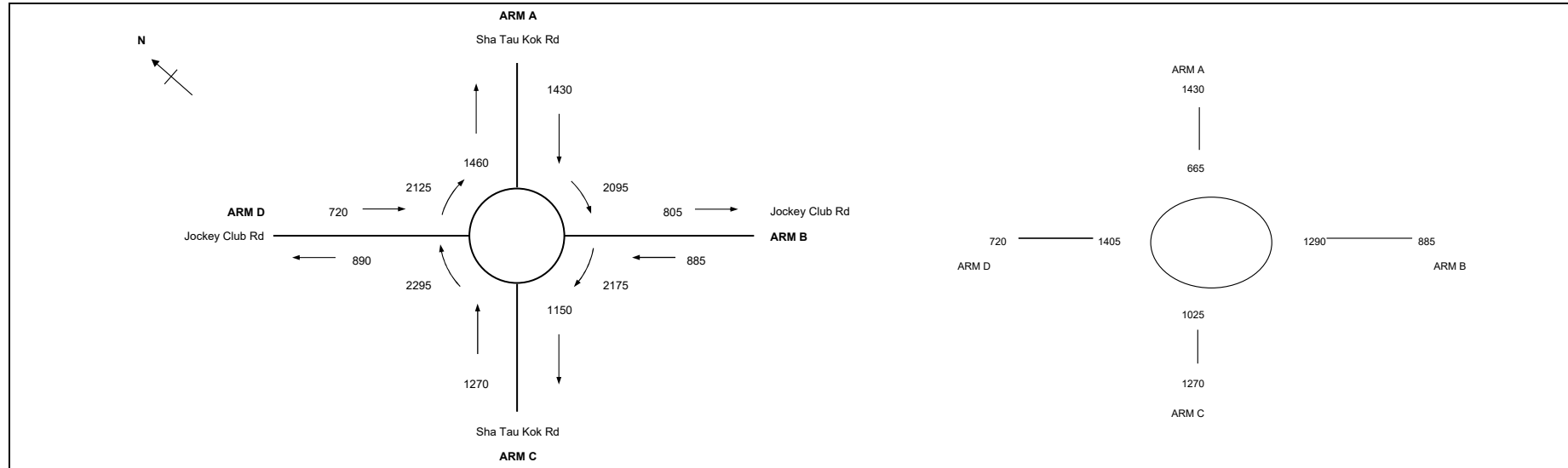

ARM	A	B	C	D
INPUT PARAMETERS:				
V = Approach half width (m)	7.30	7.30	7.30	7.30
E = Entry width (m)	9.00	8.00	9.00	8.00
L = Effective length of flare (m)	10	10	15	10
R = Entry radius (m)	30	35	50	30
D = Inscribed circle diameter (m)	65	65	65	65
A = Entry angle (degree)	20	10	15	25
Q = Entry flow (pcu/h)	1430	885	1270	720
Qc = Circulating flow across entry (pcu/h)	665	1290	1025	1405
OUTPUT PARAMETERS:				
S = Sharpness of flare = 1.6(E-V)/L	0.27	0.11	0.18	0.11
K = $1 - 0.00347(A-30) - 0.978(1/R - 0.05)$	1.05	1.09	1.08	1.03
X2 = $V + ((E-V)/(1+2S))$	8.40	7.87	8.55	7.87
M = $EXP((D-60)/10)$	1.65	1.65	1.65	1.65
F = $303 \times X2$	2546	2385	2590	2385
Td = $1 + (0.5/(1+M))$	1.19	1.19	1.19	1.19
Fc = $0.21 \times Td(1 + 0.2 \times X2)$	0.67	0.64	0.68	0.64
Qe = $K(F \times Fc \times Qc)$	2208	1697	2051	1532
DFC = Design flow/Capacity = Q/Qe	0.65	0.53	0.62	0.47
Total In Sum = 3305 PCU				
DFC of Critical Approach = 0.65				

J21 - Sha Tau Kok Road / Jockey Club Road

J21_2031_DES_AM

DATE 16/12/2024

PROJECT NO. 287082

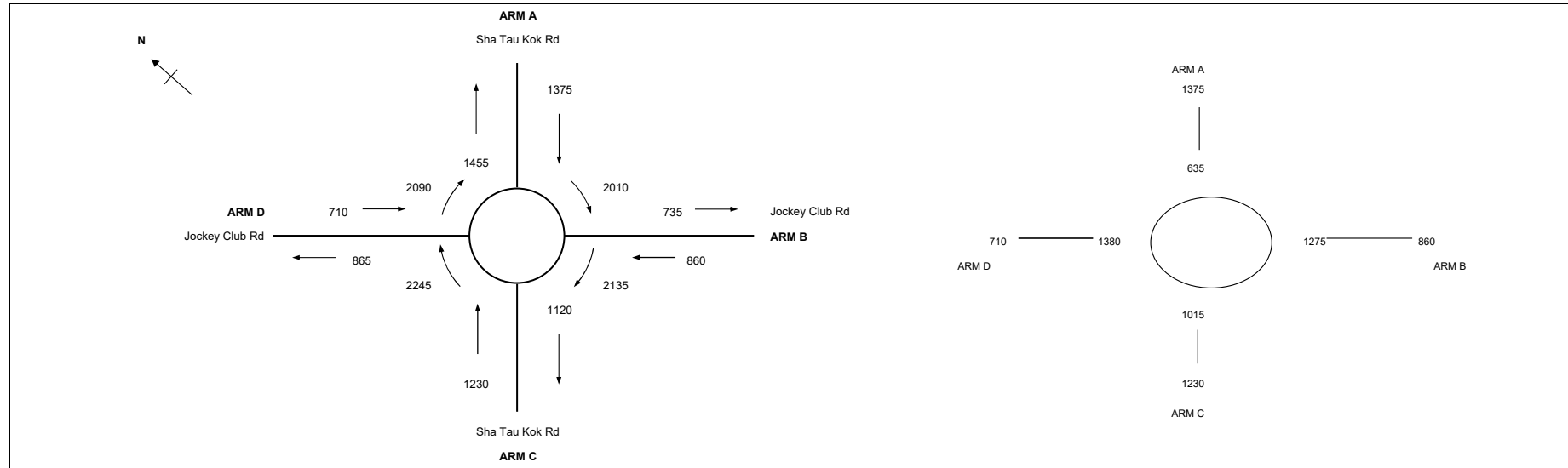

ARM	A	B	C	D	
INPUT PARAMETERS:					
V = Approach half width (m)	7.30	7.30	7.30	7.30	
E = Entry width (m)	9.00	8.00	9.00	8.00	
L = Effective length of flare (m)	10	10	15	10	
R = Entry radius (m)	30	35	50	30	
D = Inscribed circle diameter (m)	65	65	65	65	
A = Entry angle (degree)	20	10	15	25	
Q = Entry flow (pcu/h)	1375	860	1230	710	
Qc = Circulating flow across entry (pcu/h)	635	1275	1015	1380	
OUTPUT PARAMETERS:					
S = Sharpness of flare = 1.6(E-V)/L	0.27	0.11	0.18	0.11	
K = $1 - 0.00347(A-30) - 0.978(1/R - 0.05)$	1.05	1.09	1.08	1.03	
X2 = $V + ((E-V)/(1+2S))$	8.40	7.87	8.55	7.87	
M = $EXP((D-60)/10)$	1.65	1.65	1.65	1.65	
F = $303 \times X2$	2546	2385	2590	2385	
Td = $1 + (0.5/(1+M))$	1.19	1.19	1.19	1.19	
Fc = $0.21 \times Td(1 + 0.2 \times X2)$	0.67	0.64	0.68	0.64	
Qe = $K(F - Fc \times Qc)$	2229	1707	2058	1549	
DFC = Design flow/Capacity = Q/Qe	0.62	0.51	0.60	0.46	
Total In Sum =				4175	PCU
DFC of Critical Approach =				0.62	

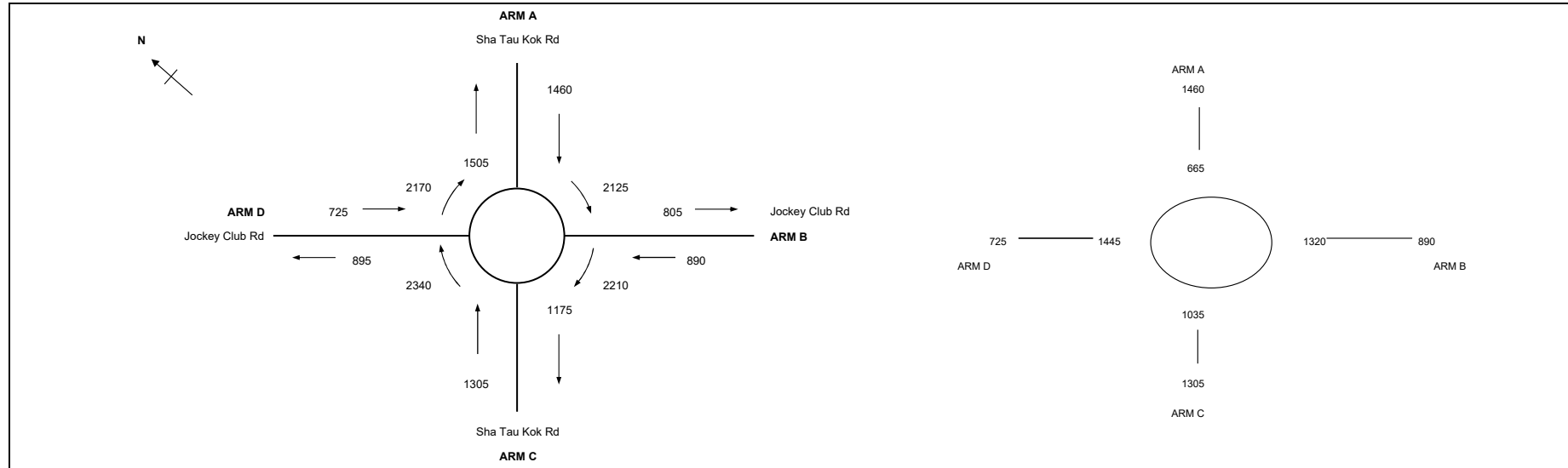

ARM	A	B	C	D
INPUT PARAMETERS:				
V = Approach half width (m)	7.30	7.30	7.30	7.30
E = Entry width (m)	9.00	8.00	9.00	8.00
L = Effective length of flare (m)	10	10	15	10
R = Entry radius (m)	30	35	50	30
D = Inscribed circle diameter (m)	65	65	65	65
A = Entry angle (degree)	20	10	15	25
Q = Entry flow (pcu/h)	1460	890	1305	725
Qc = Circulating flow across entry (pcu/h)	665	1320	1035	1445
OUTPUT PARAMETERS:				
S = Sharpness of flare = 1.6(E-V)/L	0.27	0.11	0.18	0.11
K = $1 - 0.00347(A-30) - 0.978(1/R - 0.05)$	1.05	1.09	1.08	1.03
X2 = $V + ((E-V)/(1+2S))$	8.40	7.87	8.55	7.87
M = $EXP((D-60)/10)$	1.65	1.65	1.65	1.65
F = $303 \times X2$	2546	2385	2590	2385
Td = $1 + (0.5/(1+M))$	1.19	1.19	1.19	1.19
Fc = $0.21 \times Td(1 + 0.2 \times X2)$	0.67	0.64	0.68	0.64
Qe = $K(F - Fc \times Qc)$	2208	1676	2044	1506
DFC = Design flow/Capacity = Q/Qe	0.67	0.54	0.64	0.49
Total In Sum = 4380 PCU				
DFC of Critical Approach = 0.67				

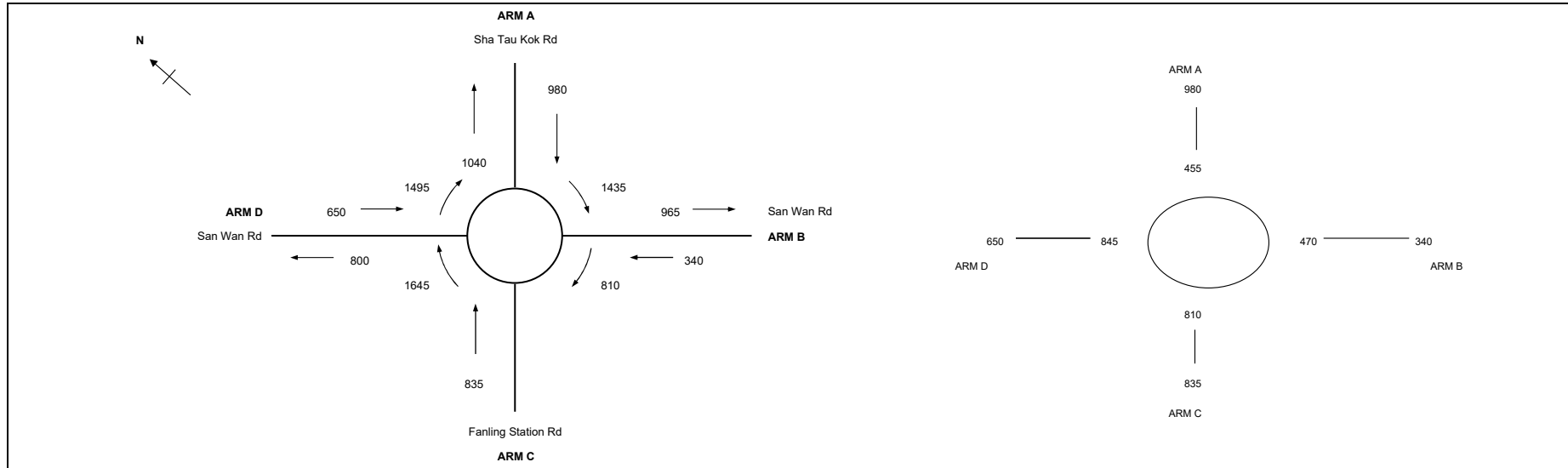

ARM	A	B	C	D
INPUT PARAMETERS:				
V = Approach half width (m)	5.50	7.30	7.30	6.00
E = Entry width (m)	10.00	10.50	10.00	7.50
L = Effective length of flare (m)	30	50	15	50
R = Entry radius (m)	100	100	25	50
D = Inscribed circle diameter (m)	55	55	55	55
A = Entry angle (degree)	10	30	30	15
Q = Entry flow (pcu/h)	980	340	835	650
Qc = Circulating flow across entry (pcu/h)	455	470	810	845
OUTPUT PARAMETERS:				
S = Sharpness of flare = 1.6(E-V)/L	0.24	0.10	0.29	0.05
K = $1 - 0.00347(A-30) - 0.978(1/R - 0.05)$	1.11	1.04	1.01	1.08
X2 = $V + ((E-V)/(1+2S))$	8.54	9.96	9.01	7.37
M = $EXP((D-60)/10)$	0.61	0.61	0.61	0.61
F = $303 \times X2$	2588	3017	2731	2233
Td = $1 + (0.5/(1+M))$	1.31	1.31	1.31	1.31
Fc = $0.21 \times Td(1 + 0.2 \times X2)$	0.75	0.82	0.77	0.68
Qe = $K(F - Fc) \times Qc$	2492	2732	2126	1792
DFC = Design flow/Capacity = Q/Qe	0.39	0.12	0.39	0.36
Total In Sum =				2805 PCU
DFC of Critical Approach =				0.39

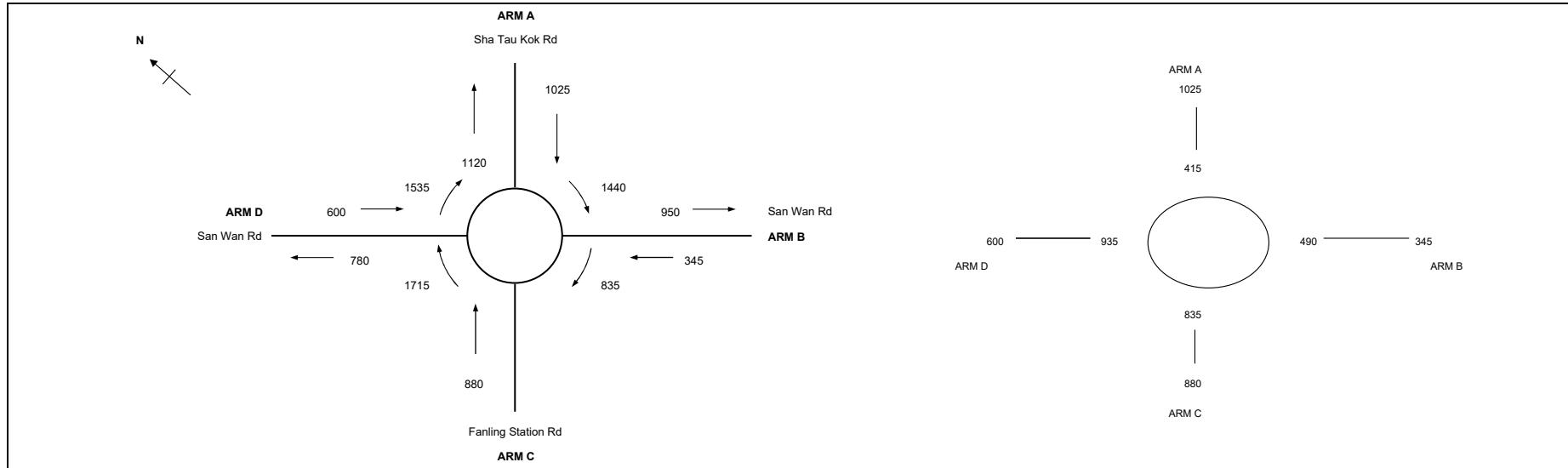

ARM	A	B	C	D	
INPUT PARAMETERS:					
V = Approach half width (m)	5.50	7.30	7.30	6.00	
E = Entry width (m)	10.00	10.50	10.00	7.50	
L = Effective length of flare (m)	30	50	15	50	
R = Entry radius (m)	100	100	25	50	
D = Inscribed circle diameter (m)	55	55	55	55	
A = Entry angle (degree)	10	30	30	15	
Q = Entry flow (pcu/h)	1025	345	880	600	
Qc = Circulating flow across entry (pcu/h)	415	490	835	935	
OUTPUT PARAMETERS:					
S = Sharpness of flare = 1.6(E-V)/L	0.24	0.10	0.29	0.05	
K = $1 - 0.00347(A-30) - 0.978(1/R - 0.05)$	1.11	1.04	1.01	1.08	
X2 = $V + ((E-V)/(1+2S))$	8.54	9.96	9.01	7.37	
M = $EXP((D-60)/10)$	0.61	0.61	0.61	0.61	
F = $303 \times X2$	2588	3017	2731	2233	
Td = $1 + (0.5/(1+M))$	1.31	1.31	1.31	1.31	
Fc = $0.21 \times Td(1 + 0.2 \times X2)$	0.75	0.82	0.77	0.68	
Qe = $K(F - Fc) \times Qc$	2526	2715	2107	1726	
DFC = Design flow/Capacity = Q/Qe	0.41	0.13	0.42	0.35	
Total In Sum =				2850	PCU
DFC of Critical Approach =				0.42	

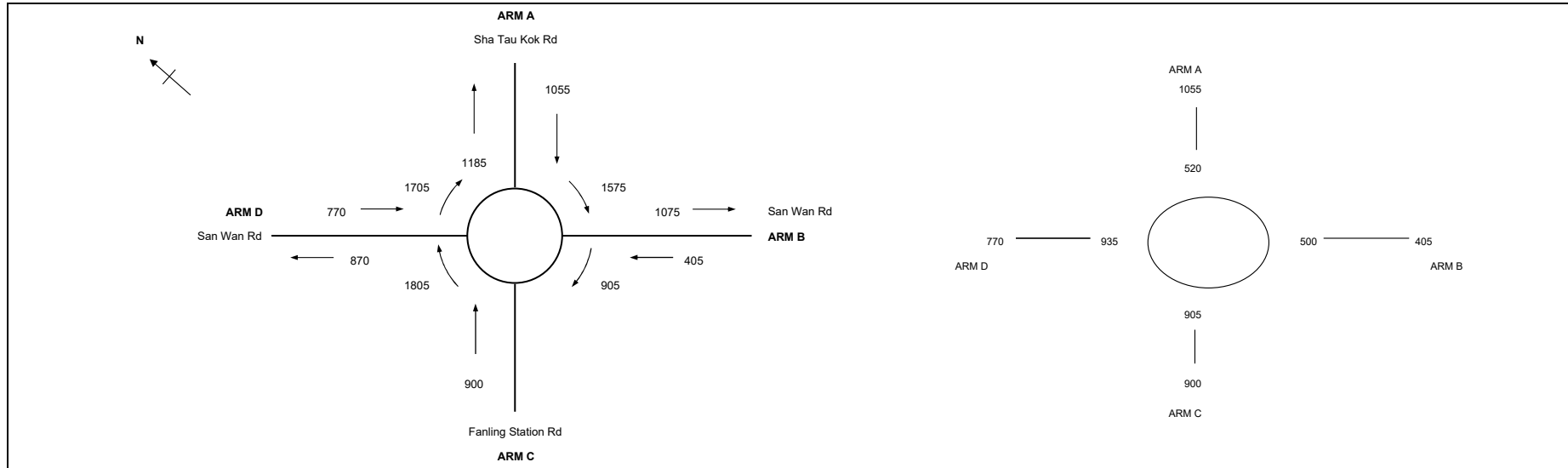

ARM	A	B	C	D
INPUT PARAMETERS:				
V = Approach half width (m)	5.50	7.30	7.30	6.00
E = Entry width (m)	10.00	10.50	10.00	7.50
L = Effective length of flare (m)	30	50	15	50
R = Entry radius (m)	100	100	25	50
D = Inscribed circle diameter (m)	55	55	55	55
A = Entry angle (degree)	10	30	30	15
Q = Entry flow (pcu/h)	1055	405	900	770
Qc = Circulating flow across entry (pcu/h)	520	500	905	935
OUTPUT PARAMETERS:				
S = Sharpness of flare = 1.6(E-V)/L	0.24	0.10	0.29	0.05
K = $1 - 0.00347(A-30) - 0.978(1/R - 0.05)$	1.11	1.04	1.01	1.08
X2 = $V + ((E-V)/(1+2S))$	8.54	9.96	9.01	7.37
M = $EXP((D-60)/10)$	0.61	0.61	0.61	0.61
F = $303 * X2$	2588	3017	2731	2233
Td = $1 + (0.5 * (1 + M))$	1.31	1.31	1.31	1.31
Fc = $0.21 * Td * (1 + 0.2 * X2)$	0.75	0.82	0.77	0.68
Qe = $K(F - Fc) * Qc$	2439	2707	2052	1726
DFC = Design flow/Capacity = Q/Qe	0.44	0.15	0.44	0.45
Total In Sum =				3130 PCU
DFC of Critical Approach =				0.45

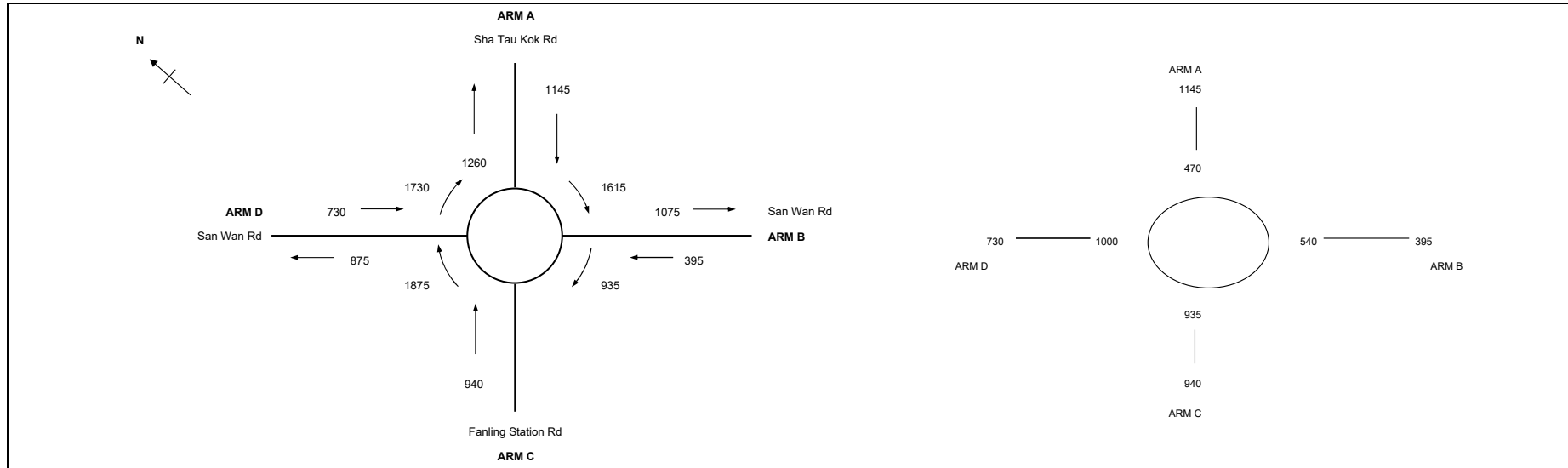

ARM	A	B	C	D
INPUT PARAMETERS:				
V = Approach half width (m)	5.50	7.30	7.30	6.00
E = Entry width (m)	10.00	10.50	10.00	7.50
L = Effective length of flare (m)	30	50	15	50
R = Entry radius (m)	100	100	25	50
D = Inscribed circle diameter (m)	55	55	55	55
A = Entry angle (degree)	10	30	30	15
Q = Entry flow (pcu/h)	1145	395	940	730
Qc = Circulating flow across entry (pcu/h)	470	540	935	1000
OUTPUT PARAMETERS:				
S = Sharpness of flare = 1.6(E-V)/L	0.24	0.10	0.29	0.05
K = $1 - 0.00347(A-30) - 0.978(1/R - 0.05)$	1.11	1.04	1.01	1.08
X2 = $V + ((E-V)/(1+2S))$	8.54	9.96	9.01	7.37
M = $EXP((D-60)/10)$	0.61	0.61	0.61	0.61
F = $303 * X2$	2588	3017	2731	2233
Td = $1 + (0.5 / (1 + M))$	1.31	1.31	1.31	1.31
Fc = $0.21 * Td * (1 + 0.2 * X2)$	0.75	0.82	0.77	0.68
Qe = $K(F - Fc) * Qc$	2480	2673	2029	1678
DFC = Design flow/Capacity = Q/Qe	0.47	0.15	0.47	0.44
Total In Sum =				3210 PCU
DFC of Critical Approach =				0.47

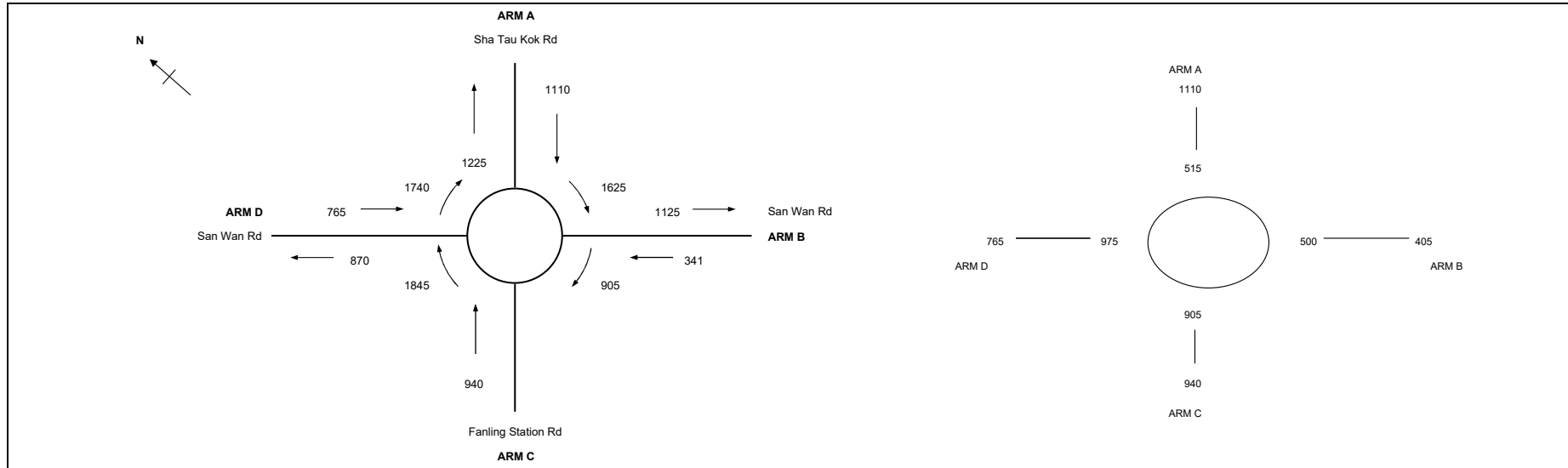

ARM	A	B	C	D
INPUT PARAMETERS:				
V = Approach half width (m)	5.50	7.30	7.30	6.00
E = Entry width (m)	10.00	10.50	10.00	7.50
L = Effective length of flare (m)	30	50	15	50
R = Entry radius (m)	100	100	25	50
D = Inscribed circle diameter (m)	55	55	55	55
A = Entry angle (degree)	10	30	30	15
Q = Entry flow (pcu/h)	1110	405	940	765
Qc = Circulating flow across entry (pcu/h)	515	500	905	975
OUTPUT PARAMETERS:				
S = Sharpness of flare = 1.6(E-V)/L	0.24	0.10	0.29	0.05
K = 1-0.00347(A-30)-0.978(1/R-0.05)	1.11	1.04	1.01	1.08
X2 = $V + ((E-V)/(1+2S))$	8.54	9.96	9.01	7.37
M = $EXP((D-60)/10)$	0.61	0.61	0.61	0.61
F = 303*X2	2588	3017	2731	2233
Td = 1+(0.5/(1+M))	1.31	1.31	1.31	1.31
Fc = 0.21*Td(1+0.2*X2)	0.75	0.82	0.77	0.68
Qe = K(F-Fc*Qc)	2443	2707	2052	1696
DFC = Design flow/Capacity = Q/Qe	0.46	0.15	0.46	0.46
Total In Sum =				3220 PCU
DFC of Critical Approach =				0.46

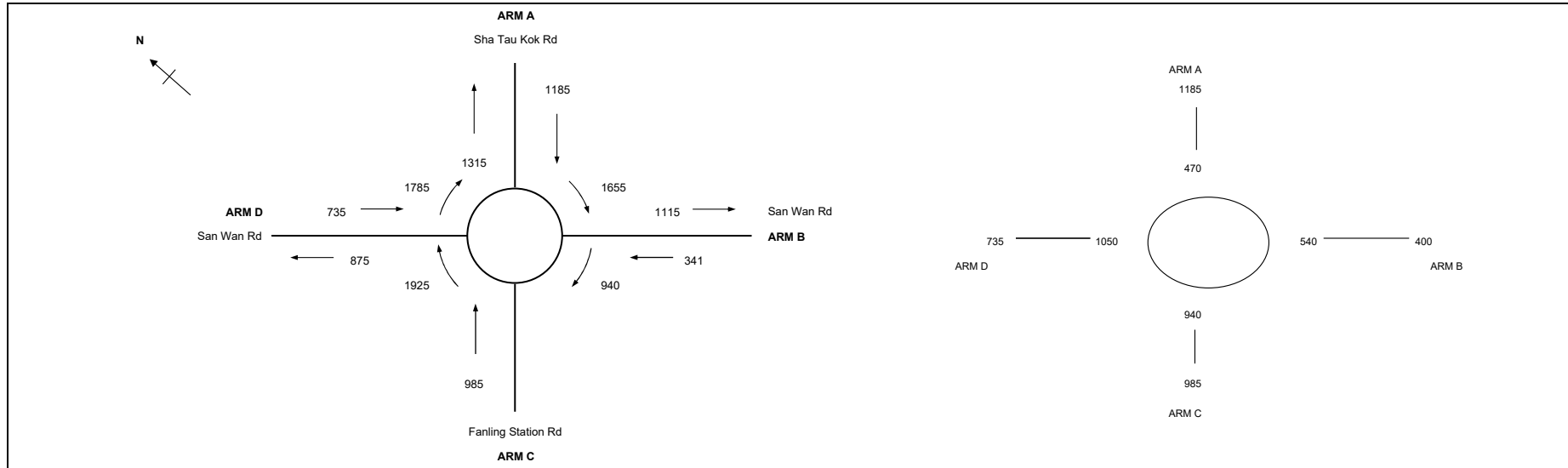

ARM	A	B	C	D
INPUT PARAMETERS:				
V = Approach half width (m)	5.50	7.30	7.30	6.00
E = Entry width (m)	10.00	10.50	10.00	7.50
L = Effective length of flare (m)	30	50	15	50
R = Entry radius (m)	100	100	25	50
D = Inscribed circle diameter (m)	55	55	55	55
A = Entry angle (degree)	10	30	30	15
Q = Entry flow (pcu/h)	1185	400	985	735
Qc = Circulating flow across entry (pcu/h)	470	540	940	1050
OUTPUT PARAMETERS:				
S = Sharpness of flare = 1.6(E-V)/L	0.24	0.10	0.29	0.05
K = 1-0.00347(A-30)-0.978(1/R-0.05)	1.11	1.04	1.01	1.08
X2 = $V + ((E-V)/(1+2S))$	8.54	9.96	9.01	7.37
M = $EXP((D-60)/10)$	0.61	0.61	0.61	0.61
F = 303*X2	2588	3017	2731	2233
Td = 1+(0.5/(1+M))	1.31	1.31	1.31	1.31
Fc = 0.21*Td(1+0.2*X2)	0.75	0.82	0.77	0.68
Qe = K(F-Fc*Qc)	2480	2673	2025	1641
DFC = Design flow/Capacity = Q/Qe	0.48	0.15	0.49	0.45
Total In Sum =				3305 PCU
DFC of Critical Approach =				0.49

J23 - San Wan Road / Fanling Station Road

J23_2023_EXT_AM

PROJECT NO: 287082

Junction No. J23

DATE : 16/12/2024

FILENAME :

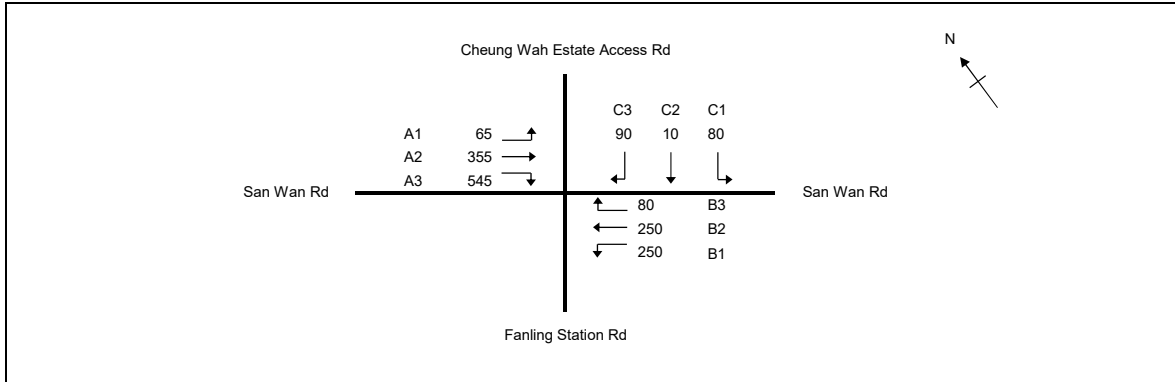

No. of stages per cycle	N = 4
No. of stage using for calculation	N = 3
Cycle time	C = 120 sec
Sum(y)	Y = 0.472
Loss time	L = 43 sec
Total Flow	= 1725 pcu
Co	= (1.5*L+5)/(1-Y) = 131.5 sec
Cm	= L/(1-Y) = 81.4 sec
Yult	= 0.578
R.C.ult	= (Yult-Y)/Y*100% = 22.5 %
Cp	= 0.9*L/(0.9-Y) = 90.3 sec
Ymax	= 1-L/C = 0.642
R.C.(C)	= (0.9*Ymax-Y)/Y*100% = 22 %

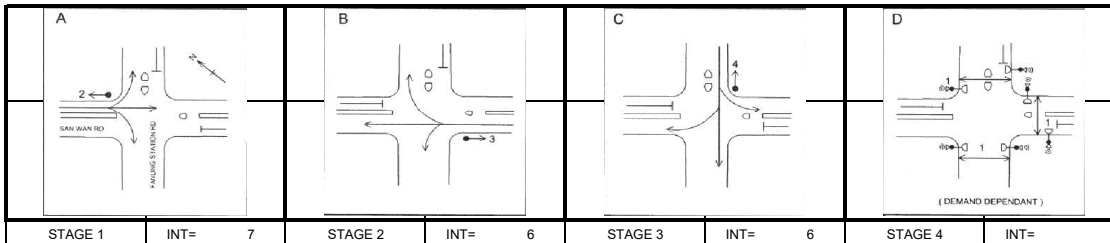

Pedestrian Phase	Width (m)	Green Time Required (s)			Green Time Provided (s)			Check
		SG	Delay	FG	SG	Delay	FG	
1	13.5	6	6	15	6	6	15	OK

Move-ment	Stage	Lane Width m.	Phase	No. of lane	Radius m.	O	N	Straight-Ahead Sat. Flow	Flow			Total Flow pcu/h	Proportion of Turning Vehicles	Sat. Flow pcu/h	Uphill Gradient %	Short lane Effect pcu/h	Revised Sat. Flow pcu/h	y	Greater y	L sec	g (required) sec	g (input) sec	Degree of Saturation X	Queuing Length m.
									Left pcu/h	Straight pcu/h	Right pcu/h													
A1	1	3.30	2	1	10		N	1945	65		65	1.00	1691			1691	0.038	0.231	16	6	38	0.122	9	
A2,A3	1	3.30	2	1	15		N	2085		355	470	0.24	2035			2035	0.231				38	38	0.735	64
A3	1	3.30	2	1	12.5		N	2085		430	430	1.00	1862			1862	0.231				38	38	0.735	59
B1,B2	2	3.60	3	1	17.5		N	1975	250	24	274	0.91	1832			1832	0.150	0.150		24	24	0.735	44	
B2,B3	2	3.60	3	1	12.5		N	2115		80	306	0.26	2051			2051	0.149			24	24	0.733	49	
C1,C2,C3	5	5.50	4	1	15		N	2165	80	10	90	0.94	1978			1978	0.091	0.091		15	15	0.735	32	
PED	4		1																27					

NOTE : 'O' - OPPOSING TRAFFIC

N - NEAR SIDE LANE

SG - STEADY GREEN

FG - FLASHING GREEN

PEDESTRIAN WALKING SPEED FOR SG(FG) = 1.2(0.9)m/s

QUEUING LENGTH = AVERAGE QUEUE * 6m

J23 - San Wan Road / Fanling Station Road

J23_2023_EXT_PM

PROJECT NO: 287082

Junction No. J23

DATE : 16/12/2024

FILENAME :

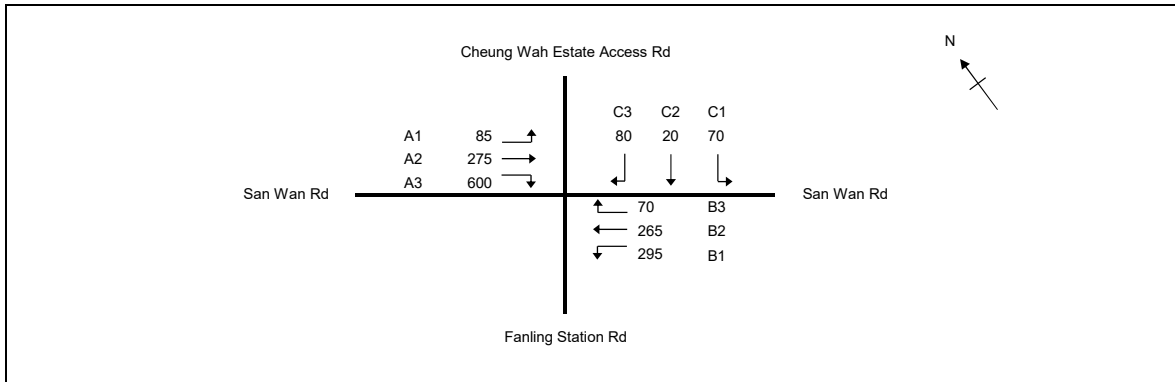

No. of stages per cycle	N = 4
No. of stage using for calculation	N = 3
Cycle time	C = 120 sec
Sum(y)	Y = 0.474
Loss time	L = 43 sec
Total Flow	= 1760 pcu
Co	= (1.5*L+5)/(1-Y) = 132.2 sec
Cm	= L/(1-Y) = 81.8 sec
Yult	= 0.578
R.C.ult	= (Yult-Y)/Y*100% = 21.8 %
Cp	= 0.9*L/(0.9-Y) = 90.9 sec
Ymax	= 1-L/C = 0.642
R.C.(C)	= (0.9*Ymax-Y)/Y*100% = 22 %

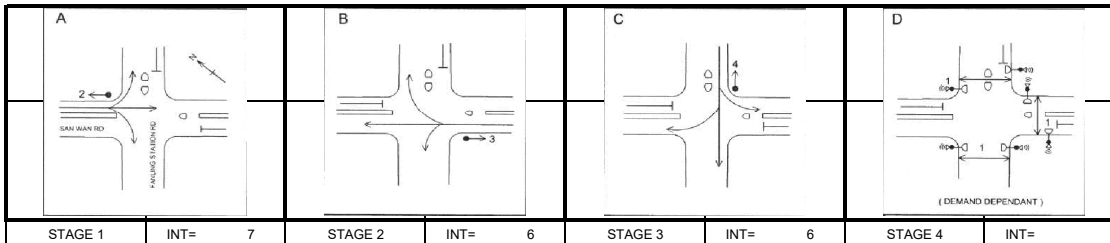

Pedestrian Phase	Width (m)	Green Time Required (s)			Green Time Provided (s)			Check
		SG	Delay	FG	SG	Delay	FG	
1	13.5	6	6	15	6	6	15	OK

Movement	Stage	Lane Width m.	Phase	No. of lane	Radius m.	O	N	Straight-Ahead Sat. Flow	Flow			Total Flow pcu/h	Proportion of Turning Vehicles	Sat. Flow pcu/h	Uphill Gradient %	Short lane Effect pcu/h	Revised Sat. Flow pcu/h	y	Greater y	L sec	g (required) sec	g (input) sec	Degree of Saturation X	Queuing Length m.
									Left pcu/h	Straight pcu/h	Right pcu/h													
A1	1	3.30	2	1	10		N	1945	85			85	1.00	1691		1691	0.050	0.226	16	8	37	0.164	12	
A2,A3	1	3.30	2	1	15		N	2085		275	179	454	0.39	2006		2006	0.226			37	37	0.739	63	
A3	1	3.30	2	1	12.5		N	2085			421	421	1.00	1862		1862	0.226			37	37	0.738	58	
B1,B2	2	3.60	3	1	17.5		N	1975	295	0		295	1.00	1819		1819	0.162	0.162		26	26	0.738	46	
B2,B3	2	3.60	3	1	12.5		N	2115		265	70	335	0.21	2063		2063	0.162			26	26	0.739	52	
C1,C2,C3	5	5.50	4	1	15		N	2165	70	20	80	170	0.88	1989		1989	0.085	0.085		14	14	0.739	30	
PED	4		1																27					

NOTE : 'O' - OPPOSING TRAFFIC N - NEAR SIDE LANE SG - STEADY GREEN FG - FLASHING GREEN PEDESTRIAN WALKING SPEED FOR SG(FG) = 1.2(0.9)m/s QUEUING LENGTH = AVERAGE QUEUE * 6m

J23 - San Wan Road / Fanling Station Road

J23_2031_REF_AM

PROJECT NO: 287082

Junction No. J23

DATE : 16/12/2024

FILENAME :

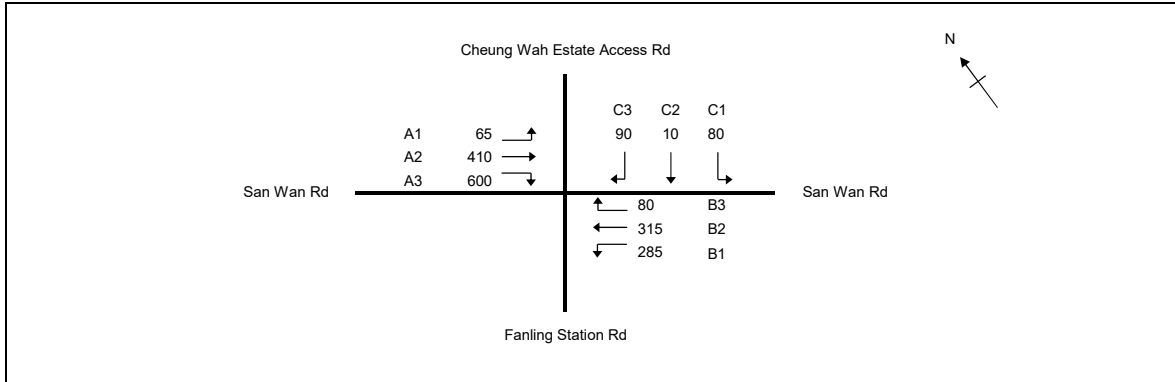

No. of stages per cycle	N =	4
No. of stage using for calculation	N =	3
Cycle time	C =	120 sec
Sum(y)	Y =	0.525
Loss time	L =	43 sec
Total Flow	=	1935 pcu
Co	= (1.5*L+5)/(1-Y)	= 146.2 sec
Cm	= L/(1-Y)	= 90.5 sec
Yult	=	0.578
R.C.ult	= (Yult-Y)/Y*100%	= 10.1 %
Cp	= 0.9*L/(0.9-Y)	= 103.1 sec
Ymax	= 1-L/C	= 0.642
R.C.(C)	= (0.9*Ymax-Y)/Y*100%	= 10 %

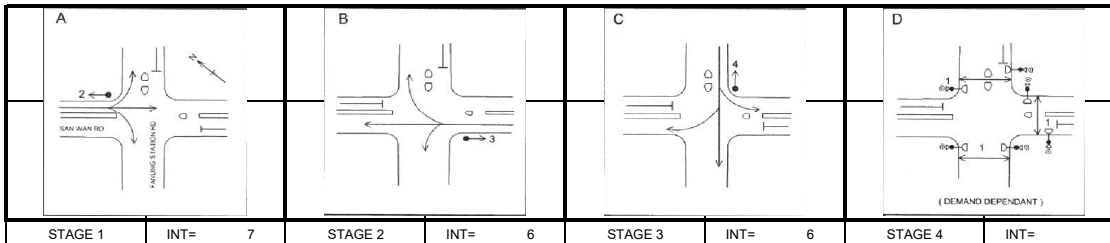

Pedestrian Phase	Width (m)	Green Time Required (s)			Green Time Provided (s)			Check
		SG	Delay	FG	SG	Delay	FG	
1	13.5	6	6	15	6	6	15	OK

Movement	Stage	Lane Width m.	Phase	No. of lane	Radius m.	O	N	Straight-Ahead Sat. Flow	Flow			Total Flow pcu/h	Proportion of Turning Vehicles	Sat. Flow pcu/h	Uphill Gradient %	Short lane Effect pcu/h	Revised Sat. Flow pcu/h	y	Greater y	L sec	g (required) sec	g (input) sec	Degree of Saturation X	Queuing Length m.
									Left pcu/h	Straight pcu/h	Right pcu/h													
A1	1	3.30	2	1	10		N	1945	65			65	1.00	1691		1691	0.038	0.259	16	6	38	0.121	9	
A2,A3	1	3.30	2	1	15		N	2085		410	118	528	0.22	2039		2039	0.259				38	38	0.818	72
A3	1	3.30	2	1	12.5		N	2085			482	482	1.00	1862		1862	0.259				38	38	0.818	66
B1,B2	2	3.60	3	1	17.5		N	1975	285	35		320	0.89	1835		1835	0.174	0.175		26	26	0.816	50	
B2,B3	2	3.60	3	1	12.5		N	2115		280	80	360	0.22	2060		2060	0.175				26	26	0.818	57
C1,C2,C3	5	5.50	4	1	15		N	2165	80	10	90	180	0.94	1978		1978	0.091	0.091			13	13	0.818	32
PED	4		1																27					

NOTE : 'O' - OPPOSING TRAFFIC N - NEAR SIDE LANE SG - STEADY GREEN FG - FLASHING GREEN PEDESTRIAN WALKING SPEED FOR SG(FG) = 1.2(0.9)m/s QUEUING LENGTH = AVERAGE QUEUE * 6m

J23 - San Wan Road / Fanling Station Road

J23_2031_REF_PM

PROJECT NO: 287082

Junction No. J23

DATE : 16/12/2024

FILENAME :

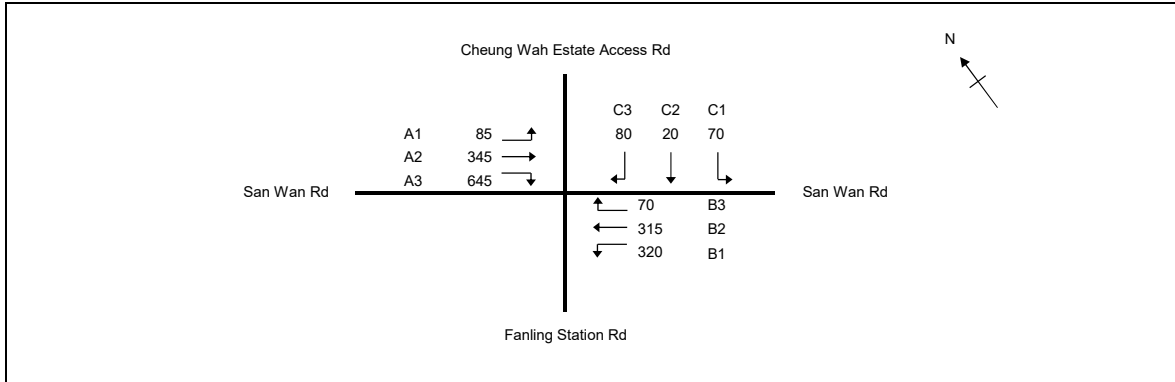

No. of stages per cycle	N = 4
No. of stage using for calculation	N = 3
Cycle time	C = 120 sec
Sum(y)	Y = 0.522
Loss time	L = 43 sec
Total Flow	= 1950 pcu
Co	= (1.5*L+5)/(1-Y) = 145.4 sec
Cm	= L/(1-Y) = 89.9 sec
Yult	= 0.578
R.C.ult	= (Yult-Y)/Y*100% = 10.7 %
Cp	= 0.9*L/(0.9-Y) = 102.3 sec
Ymax	= 1-L/C = 0.642
R.C.(C)	= (0.9*Ymax-Y)/Y*100% = 10 %

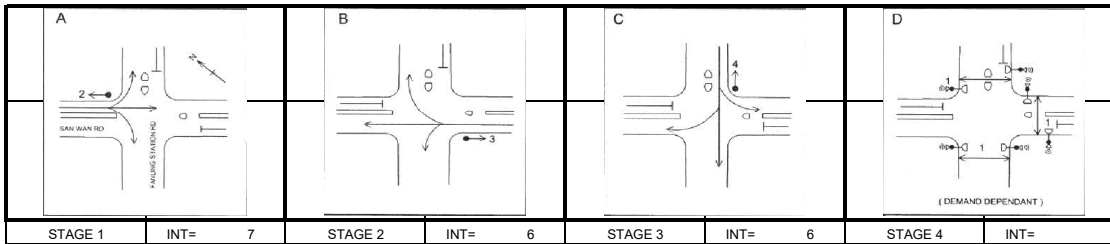

Pedestrian Phase	Width (m)	Green Time Required (s)			Green Time Provided (s)			Check
		SG	Delay	FG	SG	Delay	FG	
1	13.5	6	6	15	6	6	15	OK

Move-ment	Stage	Lane Width m.	Phase	No. of lane	Radius m.	O	N	Straight-Ahead Sat. Flow	Flow			Total Flow pcu/h	Proportion of Turning Vehicles	Sat. Flow pcu/h	Uphill Gradient %	Short lane Effect pcu/h	Revised Sat. Flow pcu/h	y	Greater y	L sec	g (required) sec	g (input) sec	Degree of Saturation X	Queuing Length m.
									Left pcu/h	Straight pcu/h	Right pcu/h													
A1	1	3.30	2	1	10		N	1945	85		85	1.00	1691			1691	0.050	0.255	16	7	38	0.160	12	
A2,A3	1	3.30	2	1	15		N	2085		345	515	0.33	2018			2018	0.255			38	38	0.813	71	
A3	1	3.30	2	1	12.5		N	2085		475	475	1.00	1862			1862	0.255			38	38	0.813	65	
B1,B2	2	3.60	3	1	17.5		N	1975	320	10	330	0.97	1823			1823	0.181	0.181		27	27	0.812	51	
B2,B3	2	3.60	3	1	12.5		N	2115		305	375	0.19	2069			2069	0.181			27	27	0.813	58	
C1,C2,C3	5	5.50	4	1	15		N	2165	70	20	80	0.88	1989			1989	0.085	0.085		13	13	0.813	30	
PED	4		1																27					

NOTE : 'O' - OPPOSING TRAFFIC

N - NEAR SIDE LANE

SG - STEADY GREEN

FG - FLASHING GREEN

PEDESTRIAN WALKING SPEED FOR SG(FG) = 1.2(0.9)m/s

QUEUING LENGTH = AVERAGE QUEUE * 6m

J23 - San Wan Road / Fanling Station Road

J23_2031_DES_PM

PROJECT NO: 287082

Junction No. J23

DATE : 16/12/2024

FILENAME :

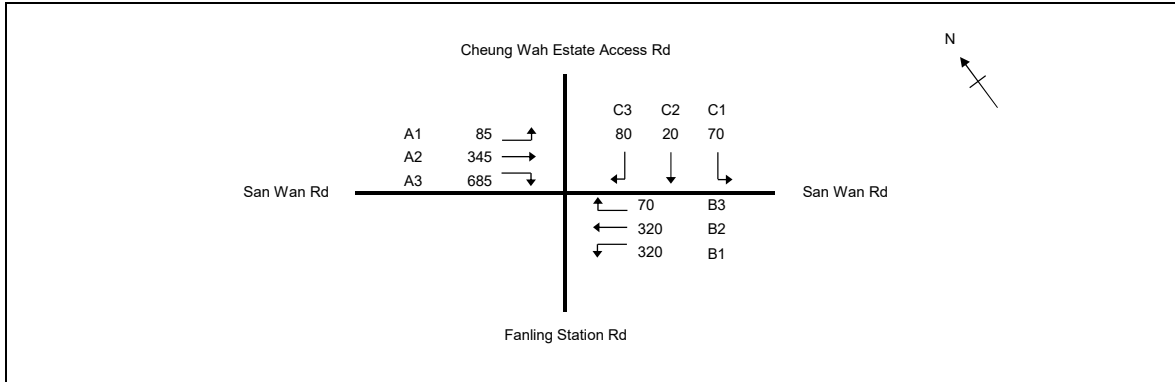

No. of stages per cycle	N = 4
No. of stage using for calculation	N = 3
Cycle time	C = 120 sec
Sum(y)	Y = 0.534
Loss time	L = 43 sec
Total Flow	= 1995 pcu
Co	= (1.5*L+5)/(1-Y) = 149.1 sec
Cm	= L/(1-Y) = 92.2 sec
Yult	= 0.578
R.C.ult	= (Yult-Y)*100% = 8.2 %
Cp	= 0.9*L/(0.9-Y) = 105.7 sec
Ymax	= 1-L/C = 0.642
R.C.(C)	= (0.9*Ymax-Y)/Y*100% = 8 %

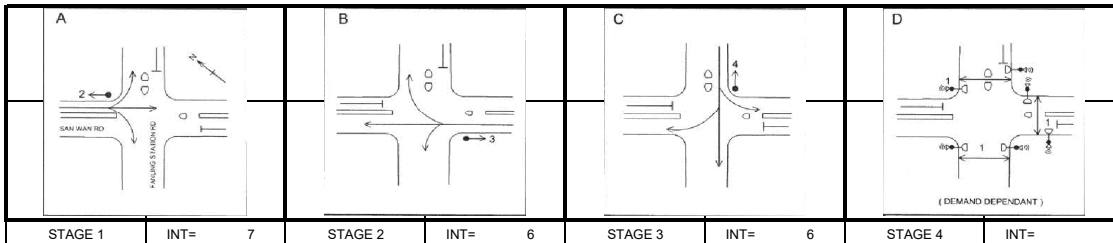

Pedestrian Phase	Width (m)	Green Time Required (s)			Green Time Provided (s)			Check
		SG	Delay	FG	SG	Delay	FG	
1	13.5	6	6	15	6	6	15	OK

Move-ment	Stage	Lane Width m.	Phase	No. of lane	Radius m.	O	N	Straight-Ahead Sat. Flow	Flow			Total Flow pcu/h	Proportion of Turning Vehicles	Sat. Flow pcu/h	Uphill Gradient %	Short lane Effect pcu/h	Revised Sat. Flow pcu/h	y	Greater y	L sec	g (required) sec	g (input) sec	Degree of Saturation X	Queuing Length m.
									Left pcu/h	Straight pcu/h	Right pcu/h													
A1	1	3.30	2	1	10		N	1945	85			85	1.00	1691		1691	0.050	0.266	16	7	38	0.157	12	
A2,A3	1	3.30	2	1	15		N	2085		345	190	535	0.36	2013		2013	0.266			38	38	0.831	73	
A3	1	3.30	2	1	12.5		N	2085		495		495	1.00	1862		1862	0.266			38	38	0.832	67	
B1,B2	2	3.60	3	1	17.5		N	1975	320	13		333	0.96	1825		1825	0.182	0.182		26	26	0.832	52	
B2,B3	2	3.60	3	1	12.5		N	2115		307	70	377	0.19	2069		2069	0.182			26	26	0.831	59	
C1,C2,C3	5	5.50	4	1	15		N	2165	70	20	80	170	0.88	1989		1989	0.085	0.085		12	12	0.832	31	
PED	4		1																27					

NOTE : 'O' - OPPOSING TRAFFIC

N - NEAR SIDE LANE

SG - STEADY GREEN

FG - FLASHING GREEN

PEDESTRIAN WALKING SPEED FOR SG(FG) = 1.2(0.9)m/s

QUEUING LENGTH = AVERAGE QUEUE * 6m

J24 - So Kwun Po Road / Jockey Club Road

J24_2023_EXT_AM

PROJECT NO: 287082

Junction No. J24

DATE: 16-Dec-24

FILENAME:

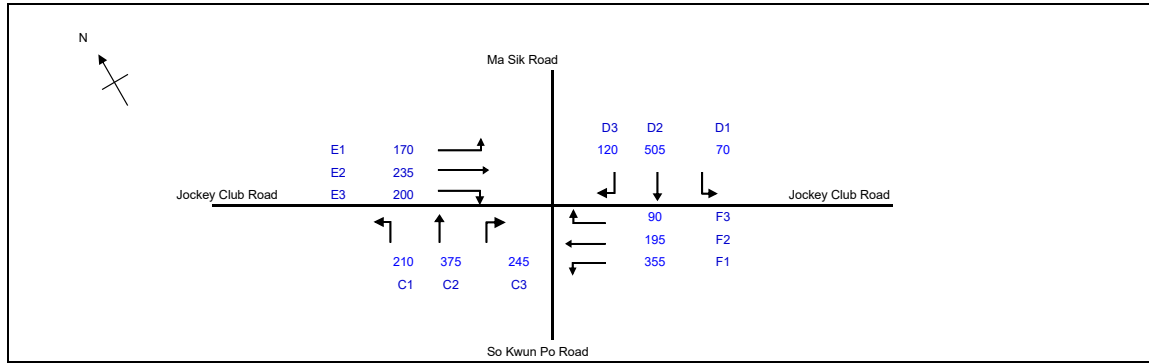

No. of stages per cycle	N =	4
No. of stage using for calculation	N =	3
Cycle time	C =	120 sec
Sum(y)	Y =	0.293
Loss time	L =	55 sec
Total Flow	=	2770 pcu
Co	= (1.5*L+5)/(1-Y)	= 123.8 sec
Cm	= L/(1-Y)	= 77.8 sec
Yult	=	0.488
R.C.ult	= (Yult-Y)/Y*100%	= 66.1 %
Cp	= 0.9*L/(0.9-Y)	= 81.6 sec
Ymax	= 1-L/C	= 0.542
R.C.(C)	= (0.9*Ymax-Y)/Y*100%	= 66 %

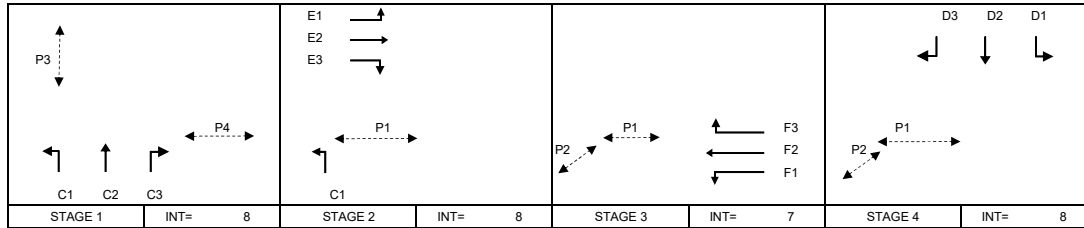

Pedestrian Phase	Width (m)	Green Time Required (s)			Green Time Provided (s)			Check
		SG	Delay	FG	SG	Delay	FG	
P1	10	6	2	11	72	2	11	OK
P2	5	6	2	6	54	2	6	OK
P3	16	13	6	16	13	6	16	OK
P4	10	6	4	11	20	4	11	OK

Movement	Stage	Lane Width m.	Phase	No. of lane	Radius m.	O	N	Straight-Ahead Sat. Flow	Flow			Total Flow pcu/h	Proportion of Turning Vehicles	Sat. Flow pcu/h	Uphill Gradient %	Short lane Effect pcu/h	Revised Sat. Flow pcu/h	y	Greater y	L sec	g (required) sec	g (input) sec	Degree of Saturation X	Queuing Length m.
									Left pcu/h	Straight pcu/h	Right pcu/h													
C1	1,2	5.00	C	1	40			2255	210			210	1.00	2173			2173	0.097		20	21	51	0.229	24
C2	1	3.30	C	1				2085		213		213	0.00	2085			2085	0.102			23	28	0.438	33
C2,C3	1	3.30	C	1	15			2085		162	47	209	0.22	2039			2039	0.102			23	28	0.439	32
C3	1	3.30	C	1	20			2085			198	198	1.00	1940			1940	0.102			23	28	0.438	30
E1	2	3.20	E	1	7.5			2075	121			121	1.00	1729			1729	0.070	0.070		16	16	0.539	21
E1,E2	2	3.20	E	1	10			2075	49	89		138	0.36	1970			1970	0.070			16	16	0.539	24
E2	2	3.20	E	1				2075		146		146	0.00	2075			2075	0.070			16	16	0.542	25
E3	2	3.20	E	2	15			4150			200	200	1.00	3773			3773	0.053			12	16	0.408	17
F1	3	3.30	F	1	7.5		N	1945	167			167	1.00	1621			1621	0.103	0.104		23	23	0.538	27
F1,F2	3	3.30	F	1	10			2085	188	0		188	1.00	1813			1813	0.104			23	23	0.542	30
F2	3	3.30	F	1				2085		195		195	0.00	2085			2085	0.094			21	23	0.489	32
F3	3	3.30	F	1	15			2085			90	90	1.00	1895			1137	0.079			18	23	0.413	15
D1	4	3.60	D	1	7.5			2115	70			70	1.00	1763			1763	0.040	0.119		9	26	0.180	11
D2	4	3.60	D	2				4230		505		505	0.00	4230			4230	0.119			26	26	0.542	39
D3	4	3.60	D	1	15			2115			120	120	1.00	1923			1923	0.062			14	26	0.283	19
PED	1		P3																	35				

NOTE: 'O' - OPPOSING TRAFFIC N - NEAR SIDE LANE SG - STEADY GREEN FG - FLASHING GREEN PEDESTRIAN WALKING SPEED OF SG/FG = 1.2(0.9)m/s QUEUING LENGTH = AVERAGE QUEUE * 6m

J24 - So Kwun Po Road / Jockey Club Road

J24_2023_EXT_PM

PROJECT NO: 287082

Junction No. J24

DATE: 16-Dec-24

FILENAME:

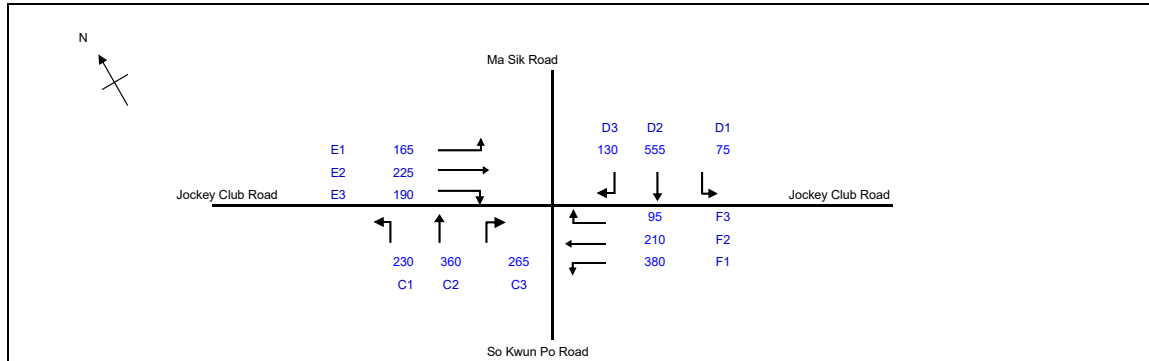

No. of stages per cycle	N = 4
No. of stage using for calculation	N = 3
Cycle time	C = 120 sec
Sum(y)	Y = 0.310
Loss time	L = 55 sec
Total Flow	= 2880 pcu
Co	= (1.5*L+5)/(1-Y) = 126.8 sec
Cm	= L/(1-Y) = 79.7 sec
Yult	= 0.488
R.C.ult	= (Yult-Y)/Y*100% = 57.4 %
Cp	= 0.9*L/(0.9-Y) = 83.9 sec
Ymax	= 1-L/C = 0.542
R.C.(C)	= (0.9*Ymax-Y)/Y*100% = 57 %

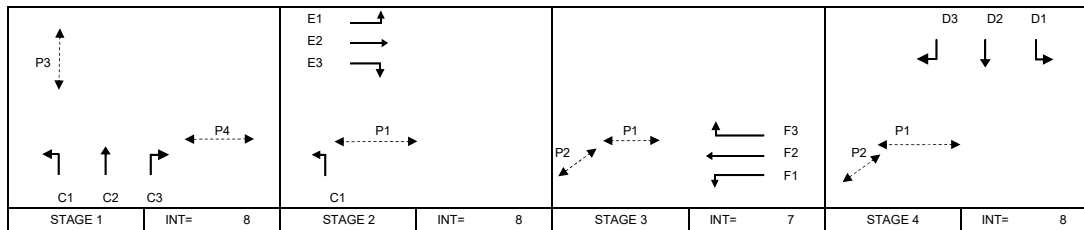

Pedestrian Phase	Width (m)	Green Time Required (s)			Green Time Provided (s)			Check
		SG	Delay	FG	SG	Delay	FG	
P1	10	6	2	11	72	2	11	OK
P2	5	6	2	6	56	2	6	OK
P3	16	13	6	16	13	6	16	OK
P4	10	6	4	11	20	4	11	OK

Movement	Stage	Lane Width m.	Phase	No. of lane	Radius m.	O	N	Straight-Ahead Sat. Flow	Flow			Total Flow pcu/h	Proportion of Turning Vehicles	Sat. Flow pcu/h	Uphill Gradient %	Short lane Effect pcu/h	Revised Sat. Flow pcu/h	y	Greater y	L sec	g (required) sec	g (input) sec	Degree of Saturation X	Queuing Length m.
									Left pcu/h	Straight pcu/h	Right pcu/h													
C1	1,2	5.00	C	1	40			2255	230			230	1.00	2173			2173	0.106		20	22	49	0.258	27
C2	1	3.30	C	1				2085		216		216	0.00	2085			2085	0.104			22	28	0.444	33
C2,C3	1	3.30	C	1	15			2085		144	65	209	0.31	2022			2022	0.103			22	28	0.442	31
C3	1	3.30	C	1	20			2085			200	200	1.00	1940			1940	0.103			22	28	0.442	31
E1	2	3.20	E	1	7.5			2075	117			117	1.00	1729			1729	0.068	0.068		14	14	0.572	21
E1,E2	2	3.20	E	1	10			2075	48	85		133	0.36	1968			1968	0.068			14	14	0.571	23
E2	2	3.20	E	1				2075		140		140	0.00	2075			2075	0.067			14	14	0.570	25
E3	2	3.20	E	2	15			4150			190	190	1.00	3773			3773	0.050			11	14	0.426	17
F1	3	3.30	F	1	7.5		N	1945	179			179	1.00	1621			1621	0.110	0.111		23	23	0.570	29
F1,F2	3	3.30	F	1	10			2085	201	0		201	1.00	1813			1813	0.111			23	23	0.572	32
F2	3	3.30	F	1				2085		210		210	0.00	2085			2085	0.101			21	23	0.519	34
F3	3	3.30	F	1	15			2085			95	95	1.00	1895			1137	0.084			18	23	0.431	15
D1	4	3.60	D	1	7.5			2115	75			75	1.00	1763			1763	0.043	0.131		9	28	0.185	12
D2	4	3.60	D	2				4230		555		555	0.00	4230			4230	0.131			28	28	0.572	43
D3	4	3.60	D	1	15			2115			130	130	1.00	1923			1923	0.068			14	28	0.295	20
PED	1		P3																	35				

NOTE: 'O' - OPPOSING TRAFFIC 'N' - NEAR SIDE LANE 'SG' - STEADY GREEN 'FG' - FLASHING GREEN PEDESTRIAN WALKING SPEED OF SG/FG = 1.2(0.9)m/s QUEUING LENGTH = AVERAGE QUEUE * 6m

J24 - So Kwun Po Road / Jockey Club Road

J24_2031_REF_AM

PROJECT NO: 287082

Junction No. J24

DATE: 16-Dec-24

FILENAME:

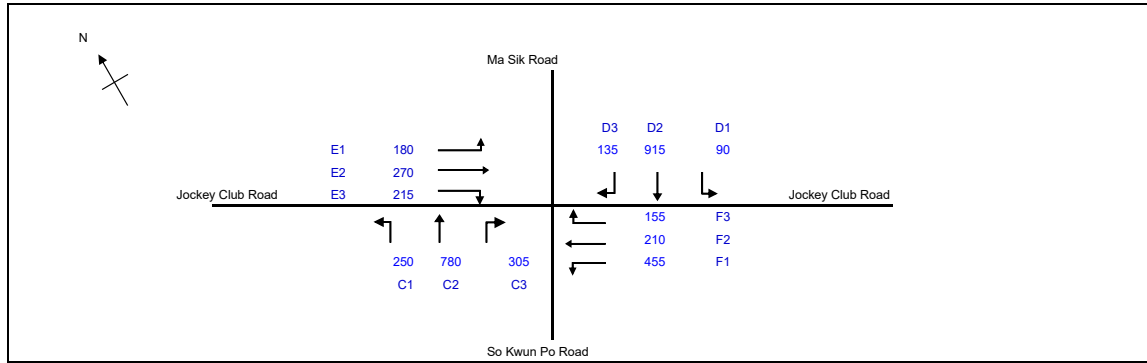

No. of stages per cycle	N = 4
No. of stage using for calculation	N = 3
Cycle time	C = 120 sec
Sum(y)	Y = 0.365
Loss time	L = 55 sec
Total Flow	= 3875 pcu
Co	= (1.5*L+5)/(1-Y) = 137.9 sec
Cm	= L/(1-Y) = 86.7 sec
Yult	= 0.488
R.C.ult	= (Yult-Y)/Y*100% = 33.4 %
Cp	= 0.9*L/(0.9-Y) = 92.6 sec
Ymax	= 1-L/C = 0.542
R.C.(C)	= (0.9*Ymax-Y)/Y*100% = 33 %

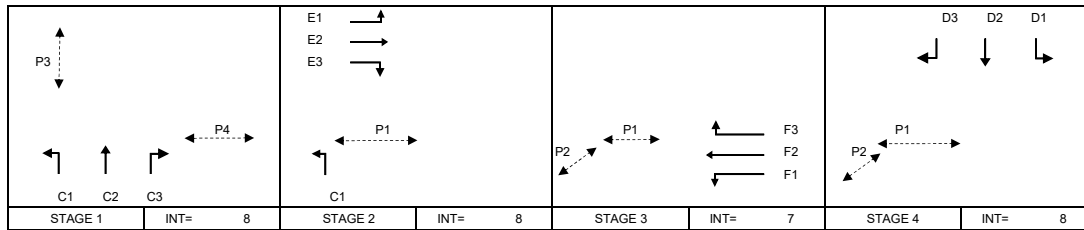

Pedestrian Phase	Width (m)	Green Time Required (s)			Green Time Provided (s)			Check
		SG	Delay	FG	SG	Delay	FG	
P1	10	6	2	11	72	2	11	OK
P2	5	6	2	6	58	2	6	OK
P3	16	13	6	16	13	6	16	OK
P4	10	6	4	11	20	4	11	OK

Movement	Stage	Lane Width m.	Phase	No. of lane	Radius m.	O	N	Straight-Ahead Sat. Flow	Flow			Total Flow pcu/h	Proportion of Turning Vehicles	Sat. Flow pcu/h	Uphill Gradient %	Short lane Effect pcu/h	Revised Sat. Flow pcu/h	y	Greater y	L sec	g (required) sec	g (input) sec	Degree of Saturation X	Queuing Length m.
									Left pcu/h	Straight pcu/h	Right pcu/h													
C1	1,2	5.00	C	1	40		N	2115	250			250	1.00	2039			2039	0.123		20	22	47	0.316	31
C2	1	3.30	C	2				4170		554		554	0.00	4170			4170	0.133			24	28	0.569	42
C2,C3	1	3.30	C	1	15			2085		226	47	273	0.17	2050			2050	0.133			24	28	0.571	42
C3	1	3.30	C	1	20			2085			258	258	1.00	1940			1940	0.133			24	28	0.570	40
E1	2	3.20	E	1	7.5		N	1935	95			95	1.00	1613			1613	0.059	0.065		10	12	0.611	17
E1,E2	2	3.20	E	1	10			2075	0	135		135	0.00	2075			2075	0.065			12	12	0.674	24
E2	2	3.20	E	1				2075		135		135	0.00	2075			2075	0.065			12	12	0.674	24
E3	2	3.20	E	2	15			4150			215	215	1.00	3773			3773	0.057			10	12	0.591	19
F1	3	3.30	F	1	7.5		N	1945	215			215	1.00	1621			1621	0.133	0.133		24	24	0.674	35
F1	3	3.30	F	1	10			2085		240		240	1.00	1813			1813	0.132			24	24	0.673	39
F2	3	3.30	F	1				2085		190		190	0.00	2085			2085	0.091			16	24	0.463	31
F2,F3	3	3.30	F	1	15			2085		20	155	175	0.89	1915			1915	0.091			16	24	0.465	28
D1	4	3.60	D	1	7.5		N	1975	90			90	1.00	1646			1646	0.055	0.168		10	30	0.220	14
D2	4	3.60	D	2				4230		709		709	0.00	4230			4230	0.168			30	30	0.674	53
D2,D3	4	3.60	D	1	15			2115		206	135	341	0.40	2034			2034	0.168			30	30	0.674	51
PED	1		P3																	35				

NOTE: 'O' - OPPOSING TRAFFIC 'N' - NEAR SIDE LANE 'SG' - STEADY GREEN 'FG' - FLASHING GREEN PEDESTRIAN WALKING SPEED OF SG/FG = 1.2(0.9)m/s QUEUING LENGTH = AVERAGE QUEUE * 6m

J24 - So Kwun Po Road / Jockey Club Road

J24_2031_REF_PM

PROJECT NO: 287082

Junction No. J24

DATE: 16-Dec-24

FILENAME:

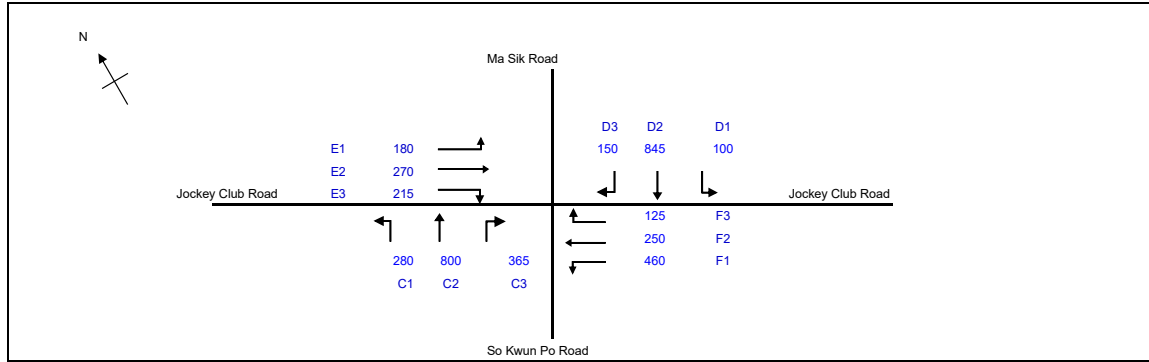

No. of stages per cycle	N = 4
No. of stage using for calculation	N = 3
Cycle time	C = 120 sec
Sum(y)	Y = 0.358
Loss time	L = 55 sec
Total Flow	= 3955 pcu
Co	= (1.5*L+5)/(1-Y) = 136.4 sec
Cm	= L/(1-Y) = 85.7 sec
Yult	= 0.488
R.C.ult	= (Yult-Y)/Y*100% = 36.0 %
Cp	= 0.9*L/(0.9-Y) = 91.4 sec
Ymax	= 1-L/C = 0.542
R.C.(C)	= (0.9*Ymax-Y)/Y*100% = 36 %

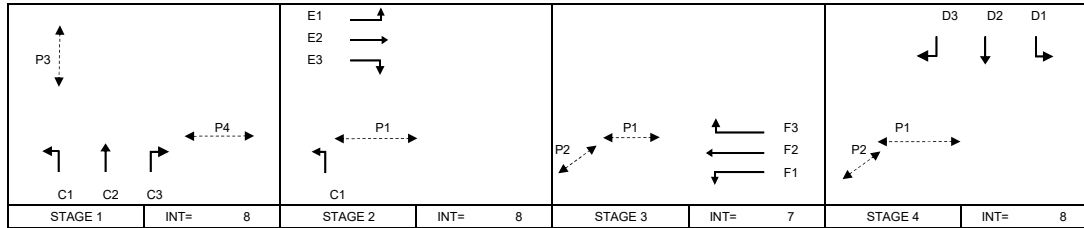

Pedestrian Phase	Width (m)	Green Time Required (s)			Green Time Provided (s)			Check
		SG	Delay	FG	SG	Delay	FG	
P1	10	6	2	11	72	2	11	OK
P2	5	6	2	6	58	2	6	OK
P3	16	13	6	16	13	6	16	OK
P4	10	6	4	11	20	4	11	OK

Movement	Stage	Lane Width m.	Phase	No. of lane	Radius m.	O	N	Straight-Ahead Sat. Flow	Flow			Total Flow pcu/h	Proportion of Turning Vehicles	Sat. Flow pcu/h	Uphill Gradient %	Short lane Effect pcu/h	Revised Sat. Flow pcu/h	y	Greater y	L sec	g (required) sec	g (input) sec	Degree of Saturation X	Queuing Length m.
									Left pcu/h	Straight pcu/h	Right pcu/h													
C1	1,2	5.00	C	1	40		N	2115	280			280	1.00	2039			2039	0.137		20	25	47	0.352	34
C2	1	3.30	C	2				4170		597		597	0.00	4170			4170	0.143			26	28	0.614	46
C2,C3	1	3.30	C	1	15			2085		203	87	290	0.30	2024			2024	0.143			26	28	0.614	44
C3	1	3.30	C	1	20			2085			278	278	1.00	1940			1940	0.143			26	28	0.614	43
E1	2	3.20	E	1	7.5		N	1935	95			95	1.00	1613			1613	0.059	0.065		11	12	0.599	17
E1,E2	2	3.20	E	1	10			2075	0	135		135	0.00	2075			2075	0.065			12	12	0.662	24
E2	2	3.20	E	1				2075		135		135	0.00	2075			2075	0.065			12	12	0.662	24
E3	2	3.20	E	2	15			4150			215	215	1.00	3773			3773	0.057			10	12	0.580	19
F1	3	3.30	F	1	7.5		N	1945	217			217	1.00	1621			1621	0.134	0.134		24	24	0.661	35
F1	3	3.30	F	1	10			2085		243		243	1.00	1813			1813	0.134			24	24	0.662	39
F2	3	3.30	F	1				2085		194		194	0.00	2085			2085	0.093			17	24	0.459	31
F2,F3	3	3.30	F	1	15			2085		56	125	181	0.69	1950			1950	0.093			17	24	0.458	29
D1	4	3.60	D	1	7.5		N	1975	100			100	1.00	1646			1646	0.061	0.159		11	29	0.252	15
D2	4	3.60	D	2				4230		673		673	0.00	4230			4230	0.159			29	29	0.661	51
D2,D3	4	3.60	D	1	15			2115		172	150	322	0.47	2021			2021	0.159			29	29	0.662	49
PED	1		P3																	35				

NOTE: 'O' - OPPOSING TRAFFIC 'N' - NEAR SIDE LANE 'SG' - STEADY GREEN 'FG' - FLASHING GREEN PEDESTRIAN WALKING SPEED OF SG/FG = 1.2(0.9)m/s QUEUING LENGTH = AVERAGE QUEUE * 6m

J24 - So Kwun Po Road / Jockey Club Road

J24_2031_DES_AM

PROJECT NO: 287082

Junction No. J24

DATE: 16-Dec-24

FILENAME:

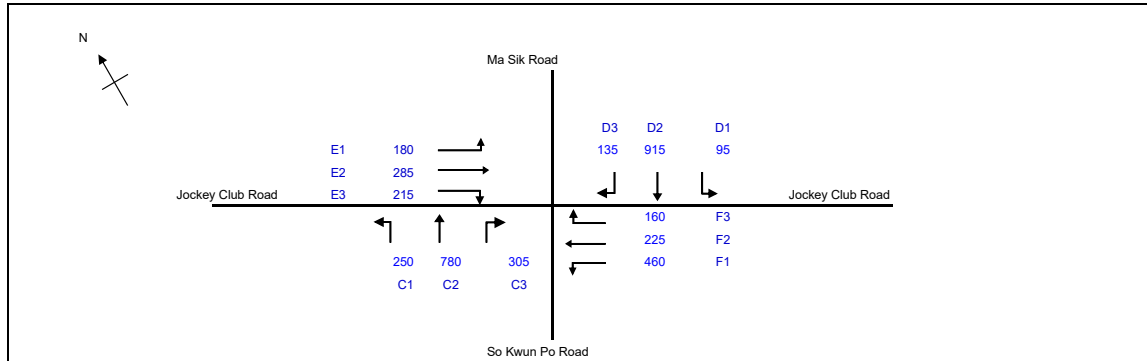

No. of stages per cycle	N = 4
No. of stage using for calculation	N = 3
Cycle time	C = 120 sec
Sum(y)	Y = 0.371
Loss time	L = 55 sec
Total Flow	= 3920 pcu
Co	= (1.5*L+5)/(1-Y) = 139.0 sec
Cm	= L/(1-Y) = 87.4 sec
Yult	= 0.488
R.C.ult	= (Yult-Y)/Y*100% = 31.6 %
Cp	= 0.9*L/(0.9-Y) = 93.5 sec
Ymax	= 1-L/C = 0.542
R.C.(C)	= (0.9*Ymax-Y)/Y*100% = 31 %

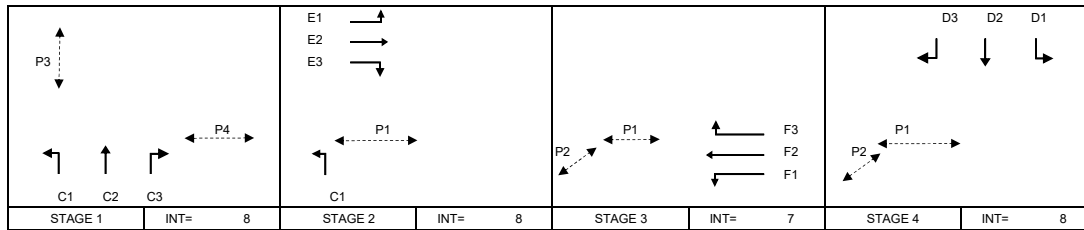

Pedestrian Phase	Width (m)	Green Time Required (s)			Green Time Provided (s)			Check
		SG	Delay	FG	SG	Delay	FG	
P1	10	6	2	11	72	2	11	OK
P2	5	6	2	6	58	2	6	OK
P3	16	13	6	16	13	6	16	OK
P4	10	6	4	11	20	4	11	OK

Movement	Stage	Lane Width m.	Phase	No. of lane	Radius m.	O	N	Straight-Ahead Sat. Flow	Flow			Total Flow pcu/h	Proportion of Turning Vehicles	Sat. Flow pcu/h	Uphill Gradient %	Short lane Effect pcu/h	Revised Sat. Flow pcu/h	y	Greater y	L sec	g (required) sec	g (input) sec	Degree of Saturation X	Queuing Length m.
									Left pcu/h	Straight pcu/h	Right pcu/h													
C1	1,2	5.00	C	1	40		N	2115	250			250	1.00	2039			2039	0.123		20	22	47	0.313	30
C2	1	3.30	C	2				4170		554		554	0.00	4170			4170	0.133			23	28	0.569	42
C2,C3	1	3.30	C	1	15			2085		226	47	273	0.17	2050			2050	0.133			23	28	0.571	42
C3	1	3.30	C	1	20			2085			258	258	1.00	1940			1940	0.133			23	28	0.570	40
E1	2	3.20	E	1	7.5		N	1935	95			95	1.00	1613			1613	0.059	0.069		10	12	0.585	17
E1,E2	2	3.20	E	1	10			2075	0	142		142	0.00	2075			2075	0.068			12	12	0.679	26
E2	2	3.20	E	1				2075		143		143	0.00	2075			2075	0.069			12	12	0.684	26
E3	2	3.20	E	2	15			4150			215	215	1.00	3773			3773	0.057			10	12	0.566	19
F1	3	3.30	F	1	7.5		N	1945	217			217	1.00	1621			1621	0.134	0.134		23	24	0.683	35
F1	3	3.30	F	1	10			2085		243		243	1.00	1813			1813	0.134			24	24	0.684	39
F2	3	3.30	F	1				2085		201		201	0.00	2085			2085	0.096			17	24	0.492	32
F2,F3	3	3.30	F	1	15			2085		24	160	184	0.87	1918			1918	0.096			17	24	0.490	30
D1	4	3.60	D	1	7.5		N	1975	95			95	1.00	1646			1646	0.058	0.168		10	29	0.236	14
D2	4	3.60	D	2				4230		709		709	0.00	4230			4230	0.168			29	29	0.684	54
D2,D3	4	3.60	D	1	15			2115		206	135	341	0.40	2034			2034	0.168			29	29	0.684	51
PED	1		P3																	35				

NOTE: 'O' - OPPOSING TRAFFIC 'N' - NEAR SIDE LANE 'SG' - STEADY GREEN 'FG' - FLASHING GREEN PEDESTRIAN WALKING SPEED OF SG/FG = 1.2(0.9)m/s QUEUING LENGTH = AVERAGE QUEUE * 6m

J24 - So Kwun Po Road / Jockey Club Road

J24_2031_DES_PM

PROJECT NO: 287082 Junction No. J24

DATE: 16-Dec-24 FILENAME:

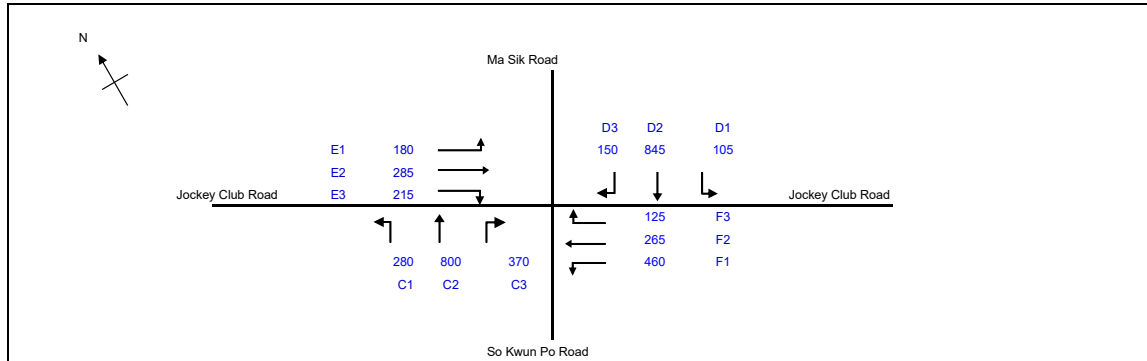

No. of stages per cycle	N = 4
No. of stage using for calculation	N = 3
Cycle time	C = 120 sec
Sum(y)	Y = 0.362
Loss time	L = 55 sec
Total Flow	= 3995 pcu
Co	= (1.5*L+5)/(1-Y) = 137.2 sec
Cm	= L/(1-Y) = 86.2 sec
Yult	= 0.488
R.C.ult	= (Yult-Y)/Y*100% = 34.6 %
Cp	= 0.9*L/(0.9-Y) = 92.1 sec
Ymax	= 1-L/C = 0.542
R.C.(C)	= (0.9*Ymax-Y)/Y*100% = 34 %

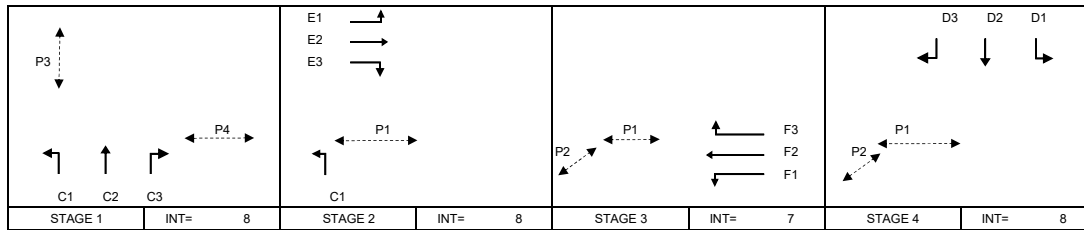

Pedestrian Phase	Width (m)	Green Time Required (s)			Green Time Provided (s)			Check
		SG	Delay	FG	SG	Delay	FG	
P1	10	6	2	11	72	2	11	OK
P2	5	6	2	6	58	2	6	OK
P3	16	13	6	16	13	6	16	OK
P4	10	6	4	11	20	4	11	OK

Movement	Stage	Lane Width m.	Phase	No. of lane	Radius m.	O	N	Straight-Ahead Sat. Flow	Flow			Total Flow pcu/h	Proportion of Turning Vehicles	Sat. Flow pcu/h	Uphill Gradient %	Short lane Effect pcu/h	Revised Sat. Flow pcu/h	y	Greater y	L sec	g (required) sec	g (input) sec	Degree of Saturation X	Queuing Length m.
									Left pcu/h	Straight pcu/h	Right pcu/h													
C1	1,2	5.00	C	1	40		N	2115	280			280	1.00	2039			2039	0.137		20	25	47	0.348	34
C2	1	3.30	C	2				4170		600		600	0.00	4170			4170	0.144			26	28	0.617	46
C2,C3	1	3.30	C	1	15			2085		200	91	291	0.31	2022			2022	0.144			26	28	0.617	45
C3	1	3.30	C	1	20			2085			279	279	1.00	1940			1940	0.144			26	28	0.616	43
E1	2	3.20	E	1	7.5		N	1935	95			95	1.00	1613			1613	0.059	0.069		11	12	0.572	17
E1,E2	2	3.20	E	1	10			2075	0	142		142	0.00	2075			2075	0.068			12	12	0.664	25
E2	2	3.20	E	1				2075		143		143	0.00	2075			2075	0.069			12	12	0.669	26
E3	2	3.20	E	2	15			4150			215	215	1.00	3773			3773	0.057			10	12	0.553	19
F1	3	3.30	F	1	7.5		N	1945	217			217	1.00	1621			1621	0.134	0.134		24	24	0.668	35
F1	3	3.30	F	1	10			2085		243		243	1.00	1813			1813	0.134			24	24	0.669	39
F2	3	3.30	F	1				2085		201		201	0.00	2085			2085	0.096			17	24	0.481	32
F2,F3	3	3.30	F	1	15			2085		64	125	189	0.66	1956			1956	0.097			17	24	0.482	30
D1	4	3.60	D	1	7.5		N	1975	105			105	1.00	1646			1646	0.064	0.159		11	29	0.288	16
D2	4	3.60	D	2				4230		673		673	0.00	4230			4230	0.159			29	29	0.668	51
D2,D3	4	3.60	D	1	15			2115		172	150	322	0.47	2021			2021	0.159			29	29	0.669	49
PED	1		P3																	35				

NOTE: 'O' - OPPOSING TRAFFIC 'N' - NEAR SIDE LANE 'SG' - STEADY GREEN 'FG' - FLASHING GREEN PEDESTRIAN WALKING SPEED OF SG/FG = 1.2(0.9)m/s QUEUING LENGTH = AVERAGE QUEUE * 6m

PROJECT NO: 287082 Junction No. J25

J25 - Jockey Club Road / Lung Sum Road

J25_2023_EXT_AM

DATE : 16-Dec-24

FILENAME :

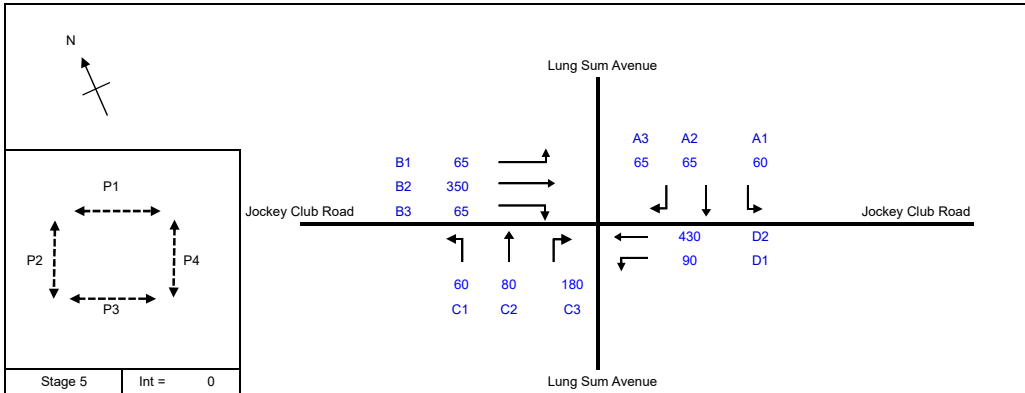

No. of stages per cycle	N =	5
No. of stage using for calculation	N =	4
Cycle time	C =	120 sec
Sum(y)	Y =	0.401
Loss time	L =	43 sec
Total Flow	=	1510 pcu
Co	= (1.5*L+5)/(1-Y)	= 115.9 sec
Cm	= L/(1-Y)	= 71.7 sec
Yult	=	0.578
R.C.ult	= (Yult-Y)/Y*100%	= 44.2 %
Cp	= 0.9*L/(0.9-Y)	= 77.5 sec
Ymax	= 1-L/C	= 0.642
R.C.(C)	= (0.9*Ymax-Y)/Y*100%	= 44 %

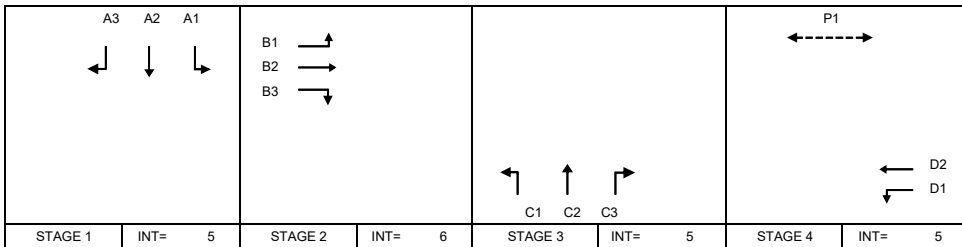

Pedestrian Phase	Width (m)	Green Time Provided (s)			Green Time Required (s)			Check
		SG	Delay	FG	SG	Delay	FG	
P1	7	6	8	6	42	8	6	OK
P2	10.5	9	7	10	9	7	10	OK
P3	10.5	9	5	10	11	5	10	OK
P4	8.5	7	2	8	16	2	8	OK

Move-ment	Stage	Lane Width m.	Phase	No. of lane	Radius m.	O	N	Straight-Ahead Sat. Flow	Flow			Total Flow pcu/h	Proportion of Turning Vehicles	Sat. Flow pcu/h	Uphill Gradient %	Short lane Effect pcu/h	Revised Sat. Flow pcu/h	y	Greater y	L sec	g (required) sec	g (input) sec	Degree of Saturation X	Queuing Length m.
									Left pcu/h	Straight pcu/h	Right pcu/h													
A1,A2	1	3.50	A	1	7.5		N	1965	60	29	65	89	0.67	1732		1732	0.051	0.051	17	10	10	0.624	16	
A2,A3	1	3.50	A	1	15			2105		36	65	101	0.64	1978		1978	0.051			10	10	0.620	19	
B1,B2	2	3.90	B	1	7.5		N	2005	65	163	65	228	0.29	1897		1897	0.120	0.121		23	23	0.623	37	
B2,B3	2	3.90	B	1	15			2145		187	65	252	0.26	2091		2091	0.121			23	23	0.624	41	
C1,C2	3	3.60	C	1	7.5		N	1975	60	80		140	0.43	1819		1819	0.077	0.094		15	18	0.513	24	
C2,C3	3	3.60	C	1	15			2115		0	180	180	1.00	1923		1923	0.094			18	18	0.624	31	
D1,D2	4	3.10	D	1	7.5		N	1925	90	152		242	0.37	1792		1792	0.135	0.135		26	26	0.624	38	
D2	4	3.10	D	1				2065		278		278	0.00	2065		2065	0.135			26	26	0.622	44	
PED	5																		26					

NOTE : 'O' - OPPOSING TRAFFIC N - NEAR SIDE LANE SG - STEADY GREEN FG - FLASHING GREEN PEDESTRIAN WALKING SPEED OF SG(FG) = 1.2(0.9)m/s QUEUING LENGTH = AVERAGE QUEUE * 6m

PROJECT NO: 287082 Junction No. J25

J25 - Jockey Club Road / Lung Sum Road

J25_2023_EXT_PM

DATE : 16-Dec-24

FILENAME :

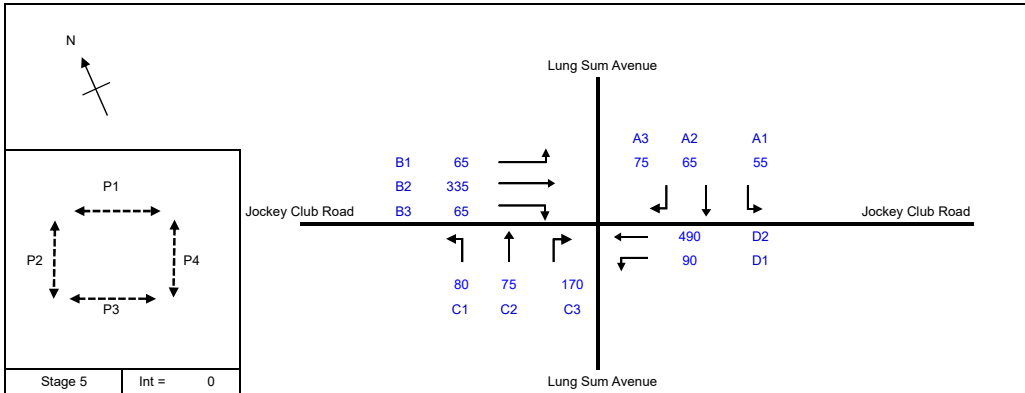

No. of stages per cycle	N =	5
No. of stage using for calculation	N =	4
Cycle time	C =	120 sec
Sum(y)	Y =	0.413
Loss time	L =	43 sec
Total Flow	=	1575 pcu
Co	= (1.5*L+5)/(1-Y)	= 118.4 sec
Cm	= L/(1-Y)	= 73.3 sec
Yult	=	0.578
R.C.ult	= (Yult-Y)/Y*100%	= 39.8 %
Cp	= 0.9*L/(0.9-Y)	= 79.5 sec
Ymax	= 1-L/C	= 0.642
R.C.(C)	= (0.9*Ymax-Y)/Y*100%	= 39 %

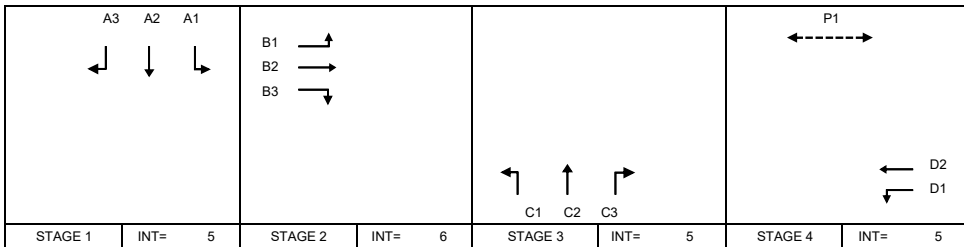

Pedestrian Phase	Width (m)	Green Time Required (s)			Green Time Provided (s)			Check
		SG	Delay	FG	SG	Delay	FG	
P1	7	6	8	6	44	8	6	OK
P2	10.5	9	7	10	9	7	10	OK
P3	10.5	9	5	10	11	5	10	OK
P4	8.5	7	2	8	16	2	8	OK

Move-ment	Stage	Lane Width m.	Phase	No. of lane	Radius m.	O	N	Straight-Ahead Sat. Flow	Flow			Total Flow pcu/h	Proportion of Turning Vehicles	Sat. Flow pcu/h	Uphill Gradient %	Short lane Effect pcu/h	Revised Sat. Flow pcu/h	y	Greater y	L sec	g (required) sec	g (input) sec	Degree of Saturation X	Queuing Length m.
									Left pcu/h	Straight pcu/h	Right pcu/h													
A1,A2	1	3.50	A	1	7.5		N	1965	55	37		92	0.60	1755		1755	0.052	0.052	17	10	10	0.643	17	
A2,A3	1	3.50	A	1	15			2105		28	75	103	0.73	1962		1962	0.052			10	10	0.644	19	
B1,B2	2	3.90	B	1	7.5		N	2005	65	156		221	0.29	1894		1894	0.117	0.117	22	22	0.643	36		
B2,B3	2	3.90	B	1	15			2145		179	65	244	0.27	2089		2089	0.117		22	22	0.644	40		
C1,C2	3	3.60	C	1	7.5		N	1975	80	75		155	0.52	1790		1790	0.087	0.094	16	17	0.595	26		
C2,C3	3	3.60	C	1	15			2115		0	180	180	1.00	1923		1923	0.094		17	17	0.644	31		
D1,D2	4	3.10	D	1	7.5		N	1925	90	181		271	0.33	1805		1805	0.150	0.150	28	28	0.644	42		
D2	4	3.10	D	1				2065		309		309	0.00	2065		2065	0.150			28	28	0.642	47	
PED	5																		26					

NOTE : 'O' - OPPOSING TRAFFIC N - NEAR SIDE LANE SG - STEADY GREEN FG - FLASHING GREEN PEDESTRIAN WALKING SPEED OF SG(FG) = 1.2(0.9)m/s QUEUING LENGTH = AVERAGE QUEUE * 6m

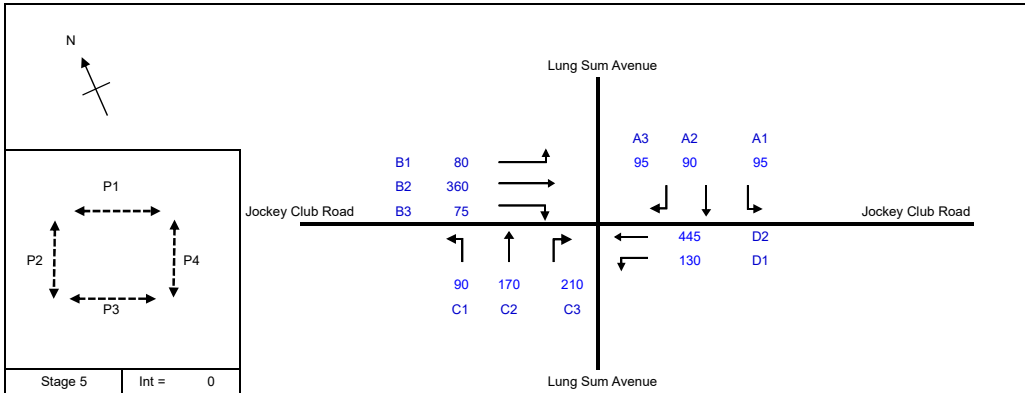

No. of stages per cycle	N = 5
No. of stage using for calculation	N = 4
Cycle time	C = 120 sec
Sum(y)	Y = 0.414
Loss time	L = 43 sec
Total Flow	= 1840 pcu
Co	= (1.5*L+5)/(1-Y) = 118.6 sec
Cm	= L/(1-Y) = 73.4 sec
Yult	= 0.578
R.C.ult	= (Yult-Y)/Y*100% = 39.5 %
Cp	= 0.9*L/(0.9-Y) = 79.6 sec
Ymax	= 1-L/C = 0.642
R.C.(C)	= (0.9*Ymax-Y)/Y*100% = 39 %

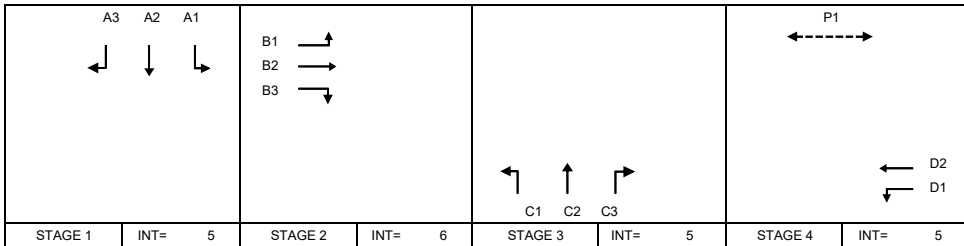

Pedestrian Phase	Width (m)	Green Time Required (s)			Green Time Provided (s)			Check
		SG	Delay	FG	SG	Delay	FG	
P1	7	6	8	6	18	8	6	OK
P2	10.5	9	7	10	9	7	10	OK
P3	10.5	9	5	10	11	5	10	OK
P4	8.5	7	2	8	16	2	8	OK

Move-ment	Stage	Lane Width m.	Phase	No. of lane	Radius m.	O	N	Straight-Ahead Sat. Flow	Flow			Total Flow pcu/h	Proportion of Turning Vehicles	Sat. Flow pcu/h	Uphill Gradient %	Short lane Effect pcu/h	Revised Sat. Flow pcu/h	y	Greater y	L sec	g (required) sec	g (input) sec	Degree of Saturation X	Queuing Length m.
									Left pcu/h	Straight pcu/h	Right pcu/h													
A1,A2	1	3.50	A	1	7.5		N	1965	95	35	130	0.73	1714			1714	0.076	0.076	17	14	14	0.645	23	
A2,A3	1	3.50	A	1	15			2105	55	95	150	0.63	1980			1980	0.076			14	14	0.645	26	
B1	2	3.90	B	1	7.5		N	2005	80		80	1.00	1671			1671	0.048	0.103		9	19	0.299	13	
B2	2	3.90	B	1				2145		221	221	0.00	2145			2145	0.103			19	19	0.644	37	
B2,B3	2	3.90	B	1	15			2145	139	75	214	0.35	2072			2072	0.103			19	19	0.645	36	
C1,C2	3	3.40	C	1	7.5		N	1955	90	56	146	0.62	1740			1740	0.084	0.084		16	16	0.642	25	
C2,C3	3	3.40	C	1	15			2095		114	171	0.33	2027			2027	0.084			16	16	0.645	30	
C3	3	3.40	C	1	10			2095		153	153	1.00	1822			1822	0.084			16	16	0.643	27	
D1,D2	4	3.10	D	1	7.5		N	1925	130	134	264	0.49	1752			1752	0.151	0.151		28	28	0.645	40	
D2	4	3.10	D	1				2065		311	311	0.00	2065			2065	0.151			28	28	0.645	48	
PED	5																		26					

NOTE : 'O' - OPPOSING TRAFFIC N - NEAR SIDE LANE SG - STEADY GREEN FG - FLASHING GREEN PEDESTRIAN WALKING SPEED OF SG(FG) = 1.2(0.9)m/s QUEUING LENGTH = AVERAGE QUEUE * 6m

PROJECT NO: 287082 Junction No. J25

J25 - Jockey Club Road / Lung Sum Road

J25_2031_REF_PM

DATE : 16-Dec-24

FILENAME :

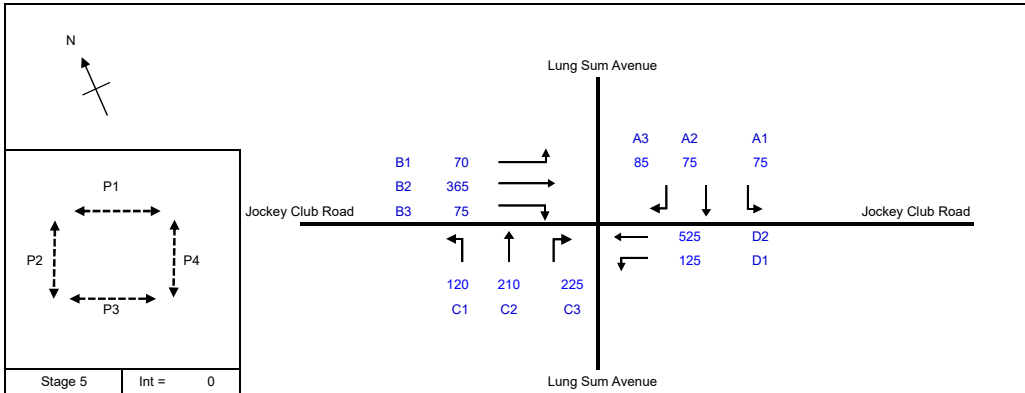

No. of stages per cycle	N =	5
No. of stage using for calculation	N =	4
Cycle time	C =	120 sec
Sum(y)	Y =	0.437
Loss time	L =	43 sec
Total Flow	=	1950 pcu
Co	= (1.5*L+5)/(1-Y)	= 123.4 sec
Cm	= L/(1-Y)	= 76.4 sec
Yult	=	0.578
R.C.ult	= (Yult-Y)/Y*100%	= 32.2 %
Cp	= 0.9*L/(0.9-Y)	= 83.6 sec
Ymax	= 1-L/C	= 0.642
R.C.(C)	= (0.9*Ymax-Y)/Y*100%	= 32 %

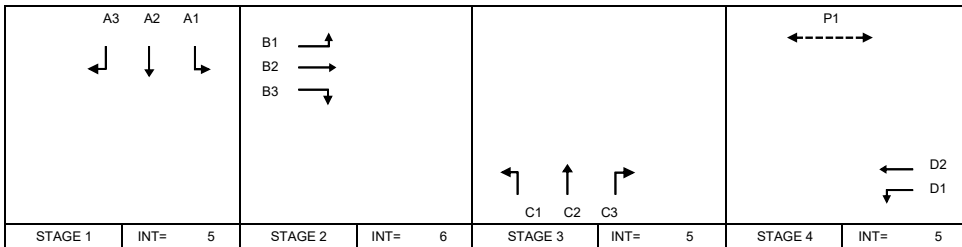

Pedestrian Phase	Width (m)	Green Time Required (s)			Green Time Provided (s)			Check
		SG	Delay	FG	SG	Delay	FG	
P1	7	6	8	6	20	8	6	OK
P2	10.5	9	7	10	9	7	10	OK
P3	10.5	9	5	10	11	5	10	OK
P4	8.5	7	2	8	16	2	8	OK

Move-ment	Stage	Lane Width m.	Phase	No. of lane	Radius m.	O	N	Straight-Ahead Sat. Flow	Flow			Total Flow pcu/h	Proportion of Turning Vehicles	Sat. Flow pcu/h	Uphill Gradient %	Short lane Effect pcu/h	Revised Sat. Flow pcu/h	y	Greater y	L sec	g (required) sec	g (input) sec	Degree of Saturation X	Queuing Length m.
									Left pcu/h	Straight pcu/h	Right pcu/h													
A1,A2	1	3.50	A	1	7.5		N	1965	75	35		110	0.68	1729		1729	0.064	0.064	17	11	11	0.681	20	
A2,A3	1	3.50	A	1	15			2105		40	85	125	0.68	1971		1971	0.063			11	11	0.679	23	
B1	2	3.90	B	1	7.5		N	2005	70			70	1.00	1671		1671	0.042	0.104		7	18	0.273	12	
B2	2	3.90	B	1				2145		224		224	0.00	2145		2145	0.104			18	18	0.681	38	
B2,B3	2	3.90	B	1	15			2145		141	75	216	0.35	2073		2073	0.104			18	18	0.679	37	
C1,C2	3	3.40	C	1	7.5		N	1955	120	50		170	0.71	1713		1713	0.099	0.099		17	18	0.679	29	
C2,C3	3	3.40	C	1	15			2095		160	44	204	0.22	2051		2051	0.099			18	18	0.681	35	
C3	3	3.40	C	1	10			2095			181	181	1.00	1822		1822	0.099			18	18	0.680	31	
D1,D2	4	3.10	D	1	7.5		N	1925	125	176		301	0.42	1777		1777	0.169	0.169		30	30	0.681	45	
D2	4	3.10	D	1				2065		349		349	0.00	2065		2065	0.169			30	30	0.679	52	
PED	5																		26					

NOTE : 'O' - OPPOSING TRAFFIC N - NEAR SIDE LANE SG - STEADY GREEN FG - FLASHING GREEN PEDESTRIAN WALKING SPEED OF SG(FG) = 1.2(0.9)m/s QUEUING LENGTH = AVERAGE QUEUE * 6m

PROJECT NO: 287082 Junction No. J25

J25 - Jockey Club Road / Lung Sum Road

J25_2031_DES_AM

DATE : 16-Dec-24

FILENAME :

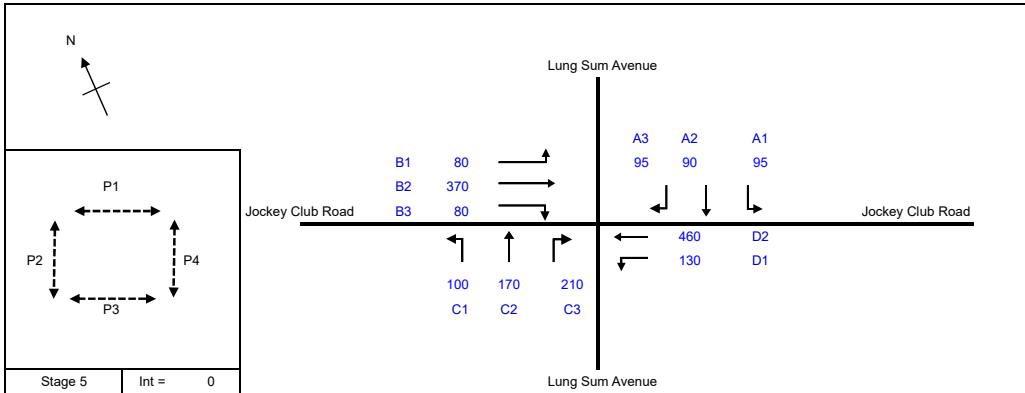

No. of stages per cycle	N =	5
No. of stage using for calculation	N =	4
Cycle time	C =	120 sec
Sum(y)	Y =	0.423
Loss time	L =	43 sec
Total Flow	=	1880 pcu
Co	= (1.5*L+5)/(1-Y)	= 120.5 sec
Cm	= L/(1-Y)	= 74.6 sec
Yult	=	0.578
R.C.ult	= (Yult-Y)/Y*100%	= 36.4 %
Cp	= 0.9*L/(0.9-Y)	= 81.2 sec
Ymax	= 1-L/C	= 0.642
R.C.(C)	= (0.9*Ymax-Y)/Y*100%	= 36 %

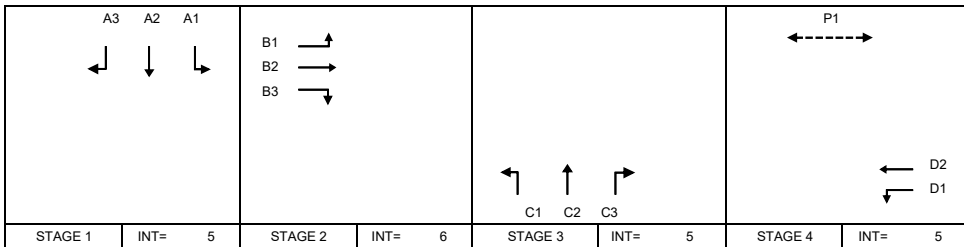

Pedestrian Phase	Width (m)	Green Time Required (s)			Green Time Provided (s)			Check
		SG	Delay	FG	SG	Delay	FG	
P1	7	6	8	6	18	8	6	OK
P2	10.5	9	7	10	9	7	10	OK
P3	10.5	9	5	10	11	5	10	OK
P4	8.5	7	2	8	16	2	8	OK

Move-ment	Stage	Lane Width m.	Phase	No. of lane	Radius m.	O	N	Straight-Ahead Sat. Flow	Flow			Total Flow pcu/h	Proportion of Turning Vehicles	Sat. Flow pcu/h	Uphill Gradient %	Short lane Effect pcu/h	Revised Sat. Flow pcu/h	y	Greater y	L sec	g (required) sec	g (input) sec	Degree of Saturation X	Queuing Length m.
									Left pcu/h	Straight pcu/h	Right pcu/h													
A1,A2	3	3.50	A	1	7.5		N	1965	95	35	130	0.73	1714			1714	0.076	0.076	17	14	14	0.660	23	
A2,A3	3	3.50	A	1	15			2105		55	95	0.63	1980			1980	0.076			14	14	0.659	27	
B1	1	3.90	B	1	7.5		N	2005	80		80	1.00	1671			1671	0.048	0.107		9	19	0.296	13	
B2	1	3.90	B	1				2145		229	229	0.00	2145			2145	0.107			19	19	0.660	38	
B2,B3	1	3.90	B	1	15			2145		141	80	0.36	2070			2070	0.107			19	19	0.660	37	
C1,C2	2	3.40	C	1	7.5		N	1955	100	48	148	0.68	1722			1722	0.086	0.086		16	16	0.658	26	
C2,C3	2	3.40	C	1	15			2095		122	53	0.30	2033			2033	0.086			16	16	0.659	30	
C3	2	3.40	C	1	10			2095		157	157	1.00	1822			1822	0.086			16	16	0.660	27	
D1,D2	4	3.10	D	1	7.5		N	1925	130	141	271	0.48	1756			1756	0.154	0.154		28	28	0.659	42	
D2	4	3.10	D	1				2065		319	319	0.00	2065			2065	0.154			28	28	0.660	49	
PED	5																		26					

NOTE : 'O' - OPPOSING TRAFFIC N - NEAR SIDE LANE SG - STEADY GREEN FG - FLASHING GREEN PEDESTRIAN WALKING SPEED OF SG(FG) = 1.2(0.9)m/s QUEUING LENGTH = AVERAGE QUEUE * 6m

PROJECT NO: 287082 Junction No. J25

J25 - Jockey Club Road / Lung Sum Road

J25_2031_DES_PM

DATE : 16-Dec-24

FILENAME :

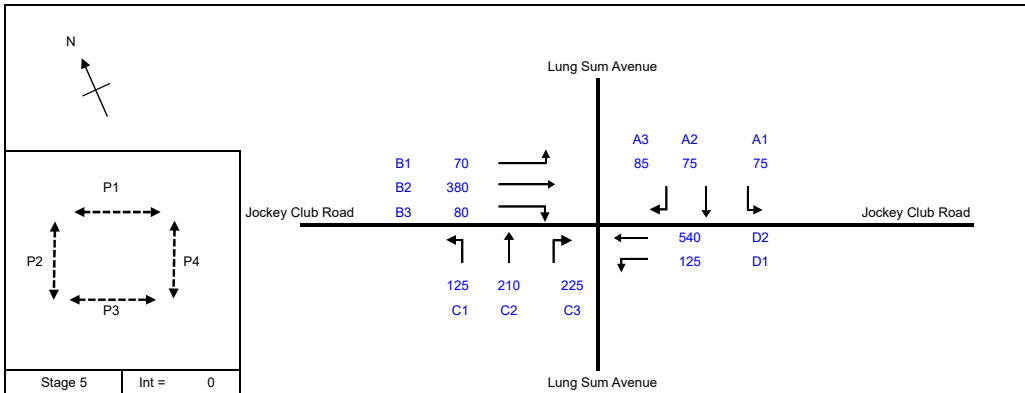

No. of stages per cycle	N =	5
No. of stage using for calculation	N =	4
Cycle time	C =	120 sec
Sum(y)	Y =	0.446
Loss time	L =	43 sec
Total Flow	=	1990 pcu
Co	= (1.5*L+5)/(1-Y)	= 125.5 sec
Cm	= L/(1-Y)	= 77.6 sec
Yult	=	0.578
R.C.ult	= (Yult-Y)/Y*100%	= 29.4 %
Cp	= 0.9*L/(0.9-Y)	= 85.3 sec
Ymax	= 1-L/C	= 0.642
R.C.(C)	= (0.9*Ymax-Y)/Y*100%	= 29 %

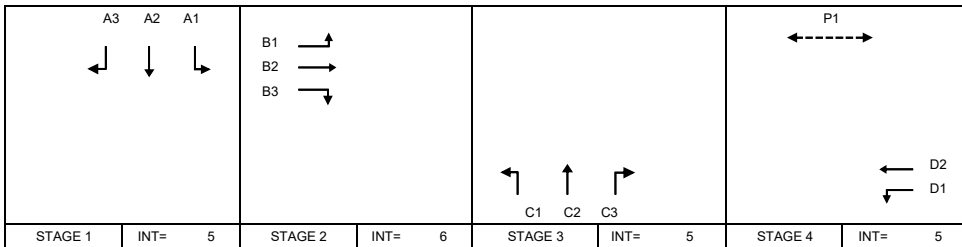

Pedestrian Phase	Width (m)	Green Time Required (s)			Green Time Provided (s)			Check
		SG	Delay	FG	SG	Delay	FG	
P1	7	6	8	6	20	8	6	OK
P2	10.5	9	7	10	9	7	10	OK
P3	10.5	9	5	10	11	5	10	OK
P4	8.5	7	2	8	16	2	8	OK

Move-ment	Stage	Lane Width m.	Phase	No. of lane	Radius m.	O	N	Straight-Ahead Sat. Flow	Flow			Total Flow pcu/h	Proportion of Turning Vehicles	Sat. Flow pcu/h	Uphill Gradient %	Short lane Effect pcu/h	Revised Sat. Flow pcu/h	y	Greater y	L sec	g (required) sec	g (input) sec	Degree of Saturation X	Queuing Length m.
									Left pcu/h	Straight pcu/h	Right pcu/h													
A1,A2	1	3.50	A	1	7.5		N	1965	75	35		110	0.68	1729		1729	0.064	0.064	17	11	11	0.695	20	
A2,A3	1	3.50	A	1	15		N	2105		40	85	125	0.68	1971		1971	0.063			11	11	0.693	23	
B1	2	3.90	B	1	7.5		N	2005	70			70	1.00	1671		1671	0.042	0.109		7	19	0.267	12	
B2	2	3.90	B	1				2145		234		234	0.00	2145		2145	0.109			19	19	0.695	39	
B2,B3	2	3.90	B	1	15			2145		146	80	226	0.35	2072		2072	0.109			19	19	0.695	38	
C1,C2	3	3.40	C	1	7.5		N	1955	125	46		171	0.73	1706		1706	0.100	0.100		17	17	0.694	29	
C2,C3	3	3.40	C	1	15			2095		164	42	206	0.20	2053		2053	0.100			17	17	0.694	35	
C3	3	3.40	C	1	10			2095			183	183	1.00	1822		1822	0.100			17	17	0.695	31	
D1,D2	4	3.10	D	1	7.5		N	1925	125	183		308	0.41	1780		1780	0.173	0.173		30	30	0.695	46	
D2	4	3.10	D	1				2065		357		357	0.00	2065		2065	0.173			30	30	0.695	54	
PED	5																			26				

NOTE : 'O' - OPPOSING TRAFFIC N - NEAR SIDE LANE SG - STEADY GREEN FG - FLASHING GREEN PEDESTRIAN WALKING SPEED OF SG(FG) = 1.2(0.9)m/s QUEUING LENGTH = AVERAGE QUEUE * 6m

Appendix D

Junction Calculation Sheets for Proposed Junction Improvement

PROJECT NO: 287082 DESIGNED BY:

J1 - Lin Ma Hang Road / Man Kam To Road

J1_2031_DES_AM_IMP

DATE : 16/12/2024 FILENAME :

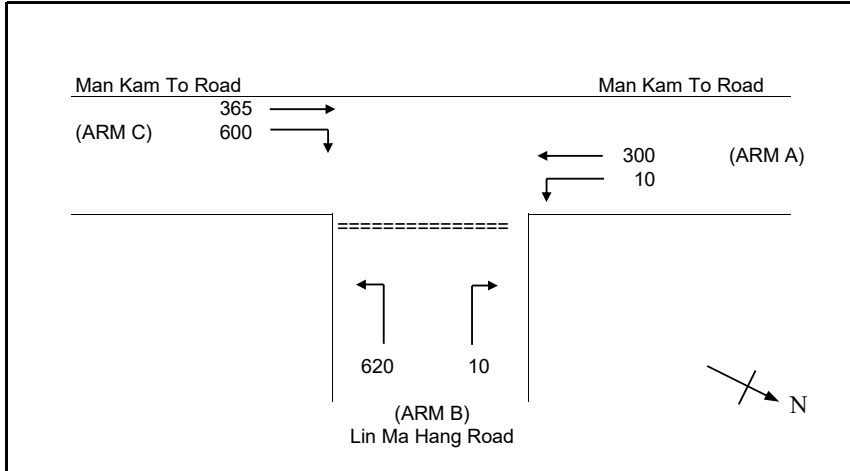

NOTES : (GEOMETRIC INPUT DATA)

- W = MAJOR ROAD WIDTH (6-20m) (minor road turn left only, 2W)
- W cr = CENTRAL RESERVE WIDTH (0m, 1.2-9m)
- W b-a = LANE WIDTH AVAILABLE TO VEHICLE WAITING IN STREAM b-a (0m, 2.2-5m)
- W b-c = LANE WIDTH AVAILABLE TO VEHICLE WAITING IN STREAM b-c (2.2-5m)
- W c-b = LANE WIDTH AVAILABLE TO VEHICLE WAITING IN STREAM c-b (0m, 2.2-5m)
- VI b-a = VISIBILITY TO THE LEFT FOR VEHICLES WAITING IN STREAM b-a (0-250m)
- Vr b-a = VISIBILITY TO THE RIGHT FOR VEHICLES WAITING IN STREAM b-a (0-250)
- Vr b-c = VISIBILITY TO THE RIGHT FOR VEHICLES WAITING IN STREAM b-c (0-250)
- Vr c-b = VISIBILITY TO THE RIGHT FOR VEHICLES WAITING IN STREAM c-b (0-250)
- D = STREAM-SPECIFIC B-A
- E = STREAM-SPECIFIC B-C
- F = STREAM-SPECIFIC C-B
- Y = (1-0.0345W)

GEOMETRIC DETAILS:

MAJOR ROAD (ARM A)
 W = 12.50 (metres)
 W cr = 0.00 (metres)
 q a-b = 10 (pcu/hr)
 q a-c = 300 (pcu/hr)

MAJOR ROAD (ARM C)
 W c-b = 5.00 (metres)
 Vr c-b = 100 (metres)
 q c-a = 365 (pcu/hr)
 q c-b = 600 (pcu/hr)

MINOR ROAD (ARM B)
 W b-a = 4.50 (metres)
 W b-c = 4.50 (metres)
 VI b-a = 80 (metres)
 Vr b-a = 125 (metres)
 Vr b-c = 125 (metres)
 q b-a = 10 (pcu/hr)
 q b-c = 620 (pcu/hr)

GEOMETRIC FACTORS :

D = 1.04
 E = 1.08
 F = 1.11
 Y = 0.57

THE CAPACITY OF MOVEMENT :

Q b-a = 352
 Q b-c = 740
 Q c-b = 753
 Q b-ac = 727

TOTAL FLOW = 1905 (PCU/HR)

COMPARISON OF DESIGN FLOW TO CAPACITY:

DFC b-a = 0.03
 DFC b-c = 0.84
 DFC c-b = 0.80

CRITICAL DFC = 0.84

PROJECT NO: 287082 DESIGNED BY:

J1 - Lin Ma Hang Road / Man Kam To Road

J1_2031_DES_PM_IMP

DATE : 16/12/2024 FILENAME :

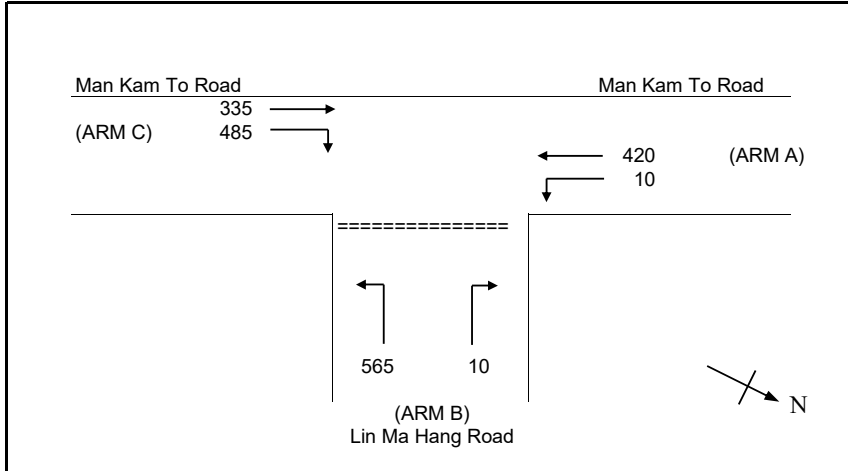

NOTES : (GEOMETRIC INPUT DATA)

- W = MAJOR ROAD WIDTH (6-20m) (minor road turn left only, 2W)
- W cr = CENTRAL RESERVE WIDTH (0m, 1.2-9m)
- W b-a = LANE WIDTH AVAILABLE TO VEHICLE WAITING IN STREAM b-a (0m, 2.2-5m)
- W b-c = LANE WIDTH AVAILABLE TO VEHICLE WAITING IN STREAM b-c (2.2-5m)
- W c-b = LANE WIDTH AVAILABLE TO VEHICLE WAITING IN STREAM c-b (0m, 2.2-5m)
- VI b-a = VISIBILITY TO THE LEFT FOR VEHICLES WAITING IN STREAM b-a (0-250m)
- Vr b-a = VISIBILITY TO THE RIGHT FOR VEHICLES WAITING IN STREAM b-a (0-250)
- Vr b-c = VISIBILITY TO THE RIGHT FOR VEHICLES WAITING IN STREAM b-c (0-250)
- Vr c-b = VISIBILITY TO THE RIGHT FOR VEHICLES WAITING IN STREAM c-b (0-250)
- D = STREAM-SPECIFIC B-A
- E = STREAM-SPECIFIC B-C
- F = STREAM-SPECIFIC C-B
- Y = (1-0.0345W)

GEOMETRIC DETAILS:

MAJOR ROAD (ARM A)

- W = 12.50 (metres)
- W cr = 0.00 (metres)
- q a-b = 10 (pcu/hr)
- q a-c = 420 (pcu/hr)

MAJOR ROAD (ARM C)

- W c-b = 5.00 (metres)
- Vr c-b = 100 (metres)
- q c-a = 335 (pcu/hr)
- q c-b = 485 (pcu/hr)

MINOR ROAD (ARM B)

- W b-a = 4.50 (metres)
- W b-c = 4.50 (metres)
- VI b-a = 80 (metres)
- Vr b-a = 125 (metres)
- Vr b-c = 125 (metres)
- q b-a = 10 (pcu/hr)
- q b-c = 565 (pcu/hr)

GEOMETRIC FACTORS :

- D = 1.04
- E = 1.08
- F = 1.11
- Y = 0.57

THE CAPACITY OF MOVEMENT :

- Q b-a = 366
- Q b-c = 713
- Q c-b = 726
- Q b-ac = 701

TOTAL FLOW = 1825 (PCU/HR)

COMPARISON OF DESIGN FLOW TO CAPACITY:

- DFC b-a = 0.03
- DFC b-c = 0.80
- DFC c-b = 0.67

CRITICAL DFC = 0.80

PROJECT NO: 287082 DESIGNED BY:

J2 - Lin Ma Hang Road / Ping Che Road

J2_2031_DES_AM_IMP

DATE : 16/12/2024 FILENAME :

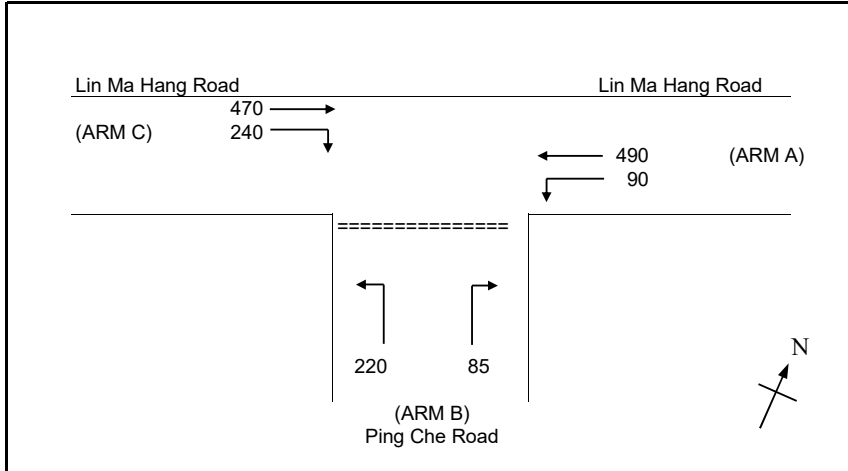

NOTES : (GEOMETRIC INPUT DATA)

- W = MAJOR ROAD WIDTH (6-20m) (minor road turn left only, 2W)
- W cr = CENTRAL RESERVE WIDTH (0m, 1.2-9m)
- W b-a = LANE WIDTH AVAILABLE TO VEHICLE WAITING IN STREAM b-a (0m, 2.2-5m)
- W b-c = LANE WIDTH AVAILABLE TO VEHICLE WAITING IN STREAM b-c (2.2-5m)
- W c-b = LANE WIDTH AVAILABLE TO VEHICLE WAITING IN STREAM c-b (0m, 2.2-5m)
- VI b-a = VISIBILITY TO THE LEFT FOR VEHICLES WAITING IN STREAM b-a (0-250m)
- Vr b-a = VISIBILITY TO THE RIGHT FOR VEHICLES WAITING IN STREAM b-a (0-250)
- Vr b-c = VISIBILITY TO THE RIGHT FOR VEHICLES WAITING IN STREAM b-c (0-250)
- Vr c-b = VISIBILITY TO THE RIGHT FOR VEHICLES WAITING IN STREAM c-b (0-250)
- D = STREAM-SPECIFIC B-A
- E = STREAM-SPECIFIC B-C
- F = STREAM-SPECIFIC C-B
- Y = (1-0.0345W)

GEOMETRIC DETAILS:

MAJOR ROAD (ARM A)

W = 7.30 (metres)
 W cr = 0.00 (metres)
 q a-b = 90 (pcu/hr)
 q a-c = 490 (pcu/hr)

MAJOR ROAD (ARM C)

W c-b = 4.00 (metres)
 Vr c-b = 100 (metres)
 q c-a = 470 (pcu/hr)
 q c-b = 240 (pcu/hr)

MINOR ROAD (ARM B)

W b-a = 3.00 (metres)
 W b-c = 3.00 (metres)
 VI b-a = 100 (metres)
 Vr b-a = 100 (metres)
 Vr b-c = 100 (metres)
 q b-a = 85 (pcu/hr)
 q b-c = 220 (pcu/hr)

GEOMETRIC FACTORS :

D = 0.89
 E = 0.92
 F = 1.01
 Y = 0.75

THE CAPACITY OF MOVEMENT :

Q b-a = 277
 Q b-c = 555
 Q c-b = 595
 Q b-ac = 434

TOTAL FLOW = 1595 (PCU/HR)

COMPARISON OF DESIGN FLOW TO CAPACITY:

DFC b-a = 0.31
 DFC b-c = 0.40
 DFC c-b = 0.41
 DFC b-ac = 0.71

CRITICAL DFC = 0.71

PROJECT NO: 287082 DESIGNED BY:

J2 - Lin Ma Hang Road / Ping Che Road

J2_2031_DES_PM_IMP

DATE : 16/12/2024 FILENAME :

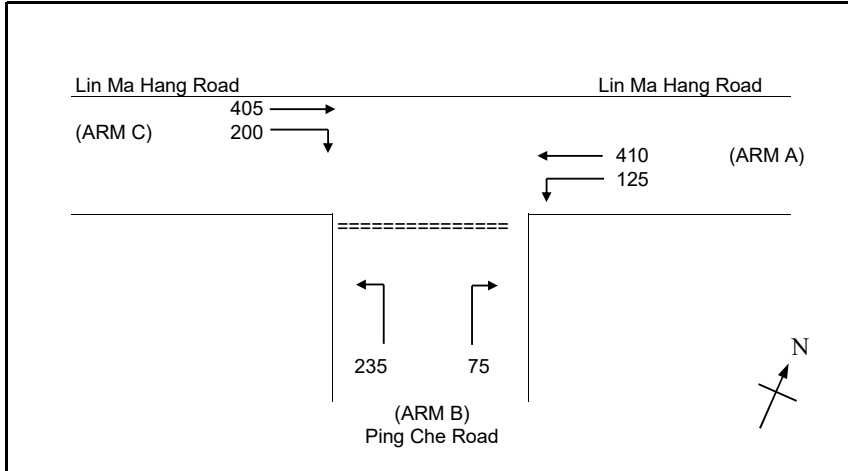

NOTES : (GEOMETRIC INPUT DATA)

- W = MAJOR ROAD WIDTH (6-20m) (minor road turn left only, 2W)
- W cr = CENTRAL RESERVE WIDTH (0m, 1.2-9m)
- W b-a = LANE WIDTH AVAILABLE TO VEHICLE WAITING IN STREAM b-a (0m, 2.2-5m)
- W b-c = LANE WIDTH AVAILABLE TO VEHICLE WAITING IN STREAM b-c (2.2-5m)
- W c-b = LANE WIDTH AVAILABLE TO VEHICLE WAITING IN STREAM c-b (0m, 2.2-5m)
- VI b-a = VISIBILITY TO THE LEFT FOR VEHICLES WAITING IN STREAM b-a (0-250m)
- Vr b-a = VISIBILITY TO THE RIGHT FOR VEHICLES WAITING IN STREAM b-a (0-250)
- Vr b-c = VISIBILITY TO THE RIGHT FOR VEHICLES WAITING IN STREAM b-c (0-250)
- Vr c-b = VISIBILITY TO THE RIGHT FOR VEHICLES WAITING IN STREAM c-b (0-250)
- D = STREAM-SPECIFIC B-A
- E = STREAM-SPECIFIC B-C
- F = STREAM-SPECIFIC C-B
- Y = (1-0.0345W)

GEOMETRIC DETAILS:

MAJOR ROAD (ARM A)
 W = 7.30 (metres)
 W cr = 0.00 (metres)
 q a-b = 125 (pcu/hr)
 q a-c = 410 (pcu/hr)

MAJOR ROAD (ARM C)
 W c-b = 4.00 (metres)
 Vr c-b = 100 (metres)
 q c-a = 405 (pcu/hr)
 q c-b = 200 (pcu/hr)

MINOR ROAD (ARM B)
 W b-a = 3.00 (metres)
 W b-c = 3.00 (metres)
 VI b-a = 100 (metres)
 Vr b-a = 100 (metres)
 Vr b-c = 100 (metres)
 q b-a = 75 (pcu/hr)
 q b-c = 235 (pcu/hr)

GEOMETRIC FACTORS :

D = 0.89
 E = 0.92
 F = 1.01
 Y = 0.75

THE CAPACITY OF MOVEMENT :

Q b-a = 317
 Q b-c = 572
 Q c-b = 608
 Q b-ac = 479

TOTAL FLOW = 1450 (PCU/HR)

COMPARISON OF DESIGN FLOW TO CAPACITY:

DFC b-a = 0.24
 DFC b-c = 0.42
 DFC c-b = 0.33
 DFC b-ac = 0.65

CRITICAL DFC = 0.65

J7 - Sha Tau Kok Road / Lung Ma Road / San Wai Barracks

J7_2031_DES_AM_WITHJ8IMP

DATE 16/12/2024

PROJECT NO. 287082

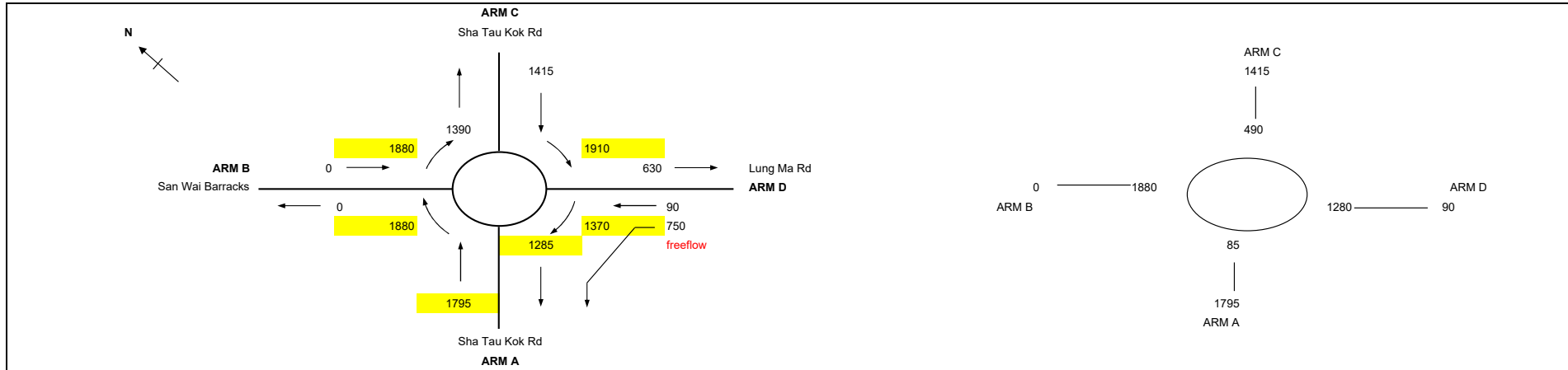

ARM	A	B	C	D
INPUT PARAMETERS:				
V = Approach half width (m)	7.30	3.30	7.30	3.50
E = Entry width (m)	10.00	5.00	10.00	5.00
L = Effective length of flare (m)	20	5	10	5
R = Entry radius (m)	30	60	30	70
D = Inscribed circle diameter (m)	50	50	50	50
A = Entry angle (degree)	15	15	25	15
Q = Entry flow (pcu/h)	1795	0	1415	90
Qc = Circulating flow across entry (pcu/h)	85	1880	490	1280
OUTPUT PARAMETERS:				
S = Sharpness of flare = 1.6(E-V)/L	0.22	0.54	0.43	0.48
K = 1-0.00347(A-30)-0.978(1/R-0.05)	1.07	1.08	1.03	1.09
X2 = V + ((E-V)/(1+2S))	9.19	4.11	8.75	4.27
M = EXP((D-60)/10)	0.37	0.37	0.37	0.37
F = 303*X2	2783	1247	2651	1292
Td = 1+(0.5/(1+M))	1.37	1.37	1.37	1.37
Fc = 0.21*Td(1+0.2*X2)	0.81	0.52	0.79	0.53
Qe = K(F-Fc*Qc)	2900	286	2341	665
DFC = Design flow/Capacity = Q/Qe	0.62	0.00	0.61	0.14
Total In Sum = 3210 PCU				
DFC of Critical Approach = 0.62				

J7 - Sha Tau Kok Road / Lung Ma Road / San Wai Barracks

J7_2031_DES_PM_WITHJ8IMP

DATE 16/12/2024

PROJECT NO. 287082

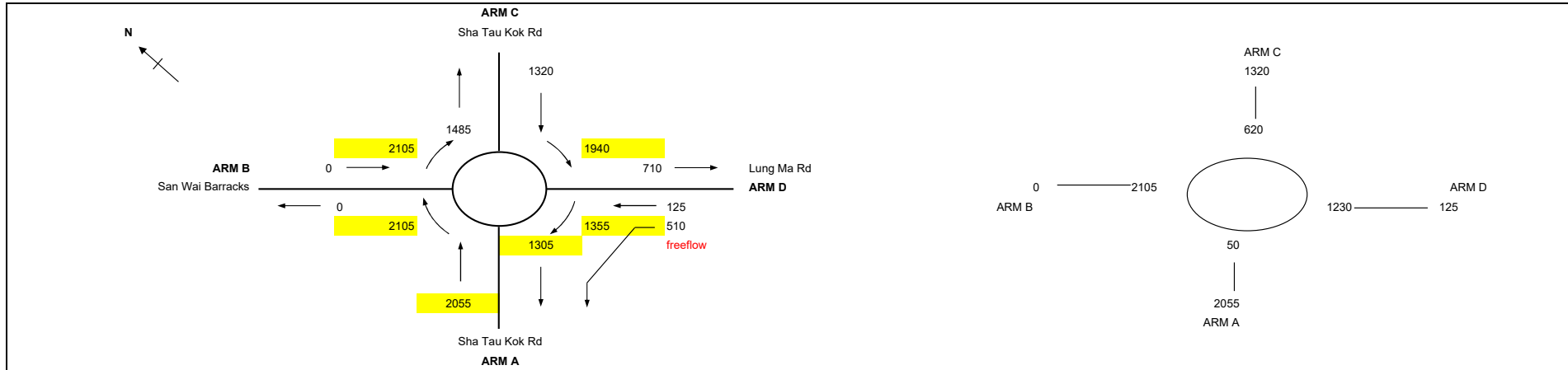

ARM	A	B	C	D		
INPUT PARAMETERS:						
V = Approach half width (m)	7.30	3.30	7.30	3.50		
E = Entry width (m)	10.00	5.00	10.00	5.00		
L = Effective length of flare (m)	20	5	10	5		
R = Entry radius (m)	30	60	30	70		
D = Inscribed circle diameter (m)	50	50	50	50		
A = Entry angle (degree)	15	15	25	15		
Q = Entry flow (pcu/h)	2055	0	1320	125		
Qc = Circulating flow across entry (pcu/h)	50	2105	620	1230		
OUTPUT PARAMETERS:						
S = Sharpness of flare = 1.6(E-V)/L	0.22	0.54	0.43	0.48		
K = 1-0.00347(A-30)-0.978(1/R-0.05)	1.07	1.08	1.03	1.09		
X2 = V + ((E-V)/(1+2S))	9.19	4.11	8.75	4.27		
M = EXP((D-60)/10)	0.37	0.37	0.37	0.37		
F = 303*X2	2783	1247	2651	1292		
Td = 1+(0.5/(1+M))	1.37	1.37	1.37	1.37		
Fc = 0.21*Td(1+0.2*X2)	0.81	0.52	0.79	0.53		
Qe = K(F-Fc*Qc)	2930	159	2235	694	Total In Sum =	3375 PCU
DFC = Design flow/Capacity = Q/Qe	0.71	0.00	0.60	0.19	DFC of Critical Approach =	0.71

J8 - Sha Tau Kok Road / Sui Wan Road

J8_2031_DES_AM_IMP

PROJECT NO: 287082

Junction No. J8

DATE : 16/12/2024

FILENAME :

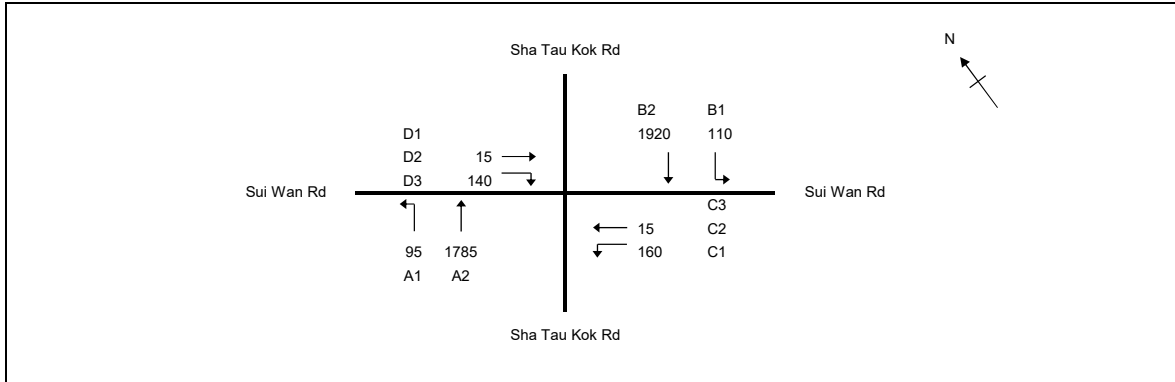

No. of stages per cycle	N = 3
No. of stage using for calculation	N = 3
Cycle time	C = 135 sec
Sum(y)	Y = 0.636
Loss time	L = 12 sec
Total Flow	= 4240 pcu
Co	= (1.5*L+5)/(1-Y) = 63.2 sec
Cm	= L/(1-Y) = 33.0 sec
Yult	= 0.810
R.C.ult	= (Yult-Y)*100% = 27.3 %
Cp	= 0.9*L/(0.9-Y) = 40.9 sec
Ymax	= 1-L/C = 0.911
R.C.(C)	= (0.9*Ymax-Y)*100% = 28 %

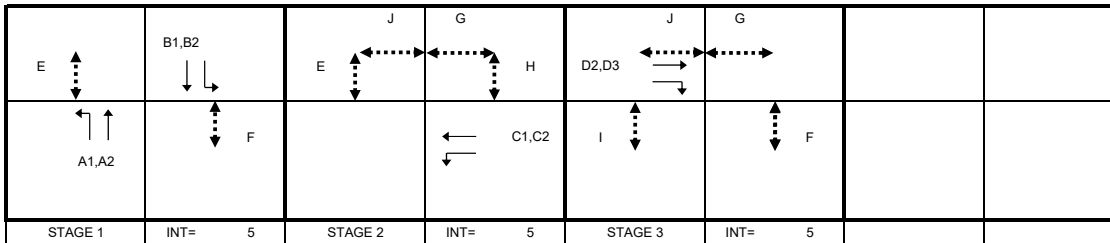

Pedestrian Phase	Width (m)	Green Time Required (s)			Green Time Provided (s)			Check
		SG	Delay	FG	SG	Delay	FG	
E	5	6	2	6	106	2	6	OK
F	5	6	2	6	104	2	6	OK
G	10.5	6	5	12	27	5	12	OK
H	5	6	2	6	15	2	6	OK
I	5	6	2	6	13	2	6	OK
J	8	6	5	9	30	5	9	OK

Move-ment	Stage	Lane Width m.	Phase	No. of lane	Radius m.	O	N	Straight-Ahead Sat. Flow	Flow			Total Flow pcu/h	Proportion of Turning Vehicles	Sat. Flow pcu/h	Uphill Gradient %	Short lane Effect pcu/h	Revised Sat. Flow pcu/h	y	Greater y	L sec	g (required) sec	g (input) sec	Degree of Saturation X	Queuing Length m.
									Left pcu/h	Straight pcu/h	Right pcu/h													
B1,B2	1	3.50	B	1	10		N	1965	110	525		635	0.17	1915		1915	0.332	0.450	12	64	87	0.514	51	
B2	1	3.50	B	2				4210		1395		1395	0.00	4210		4210	0.331			64	87	0.514	56	
A1,A2	1	3.50	A	1	10			2105	95	838		933	0.10	2073		2073	0.450			87	87	0.698	75	
A2	1	3.50	A	1				2105		947		947	0.00	2105		2105	0.450			87	87	0.698	76	
C1,C2,C3	2	4.00	C	1	10		N	2015	160	15	0	175	0.91	1772		1772	0.099	0.099		19	19	0.698	34	
D1,D2,D3	3	4.00	D	1	10		N	2015	0	15	140	155	0.90	1775		1775	0.087	0.087		17	17	0.698	31	

NOTE : 'O' - OPPOSING TRAFFIC

N - NEAR SIDE LANE

SG - STEADY GREEN

FG - FLASHING GREEN

PEDESTRIAN WALKING SPEED FOR SG(FG) = 1.2(0.9)m/s

QUEUING LENGTH = AVERAGE QUEUE * 6m

J8 - Sha Tau Kok Road / Sui Wan Road

J8_2031_DES_PM_IMP

PROJECT NO: 287082

Junction No. J8

DATE : 16/12/2024

FILENAME :

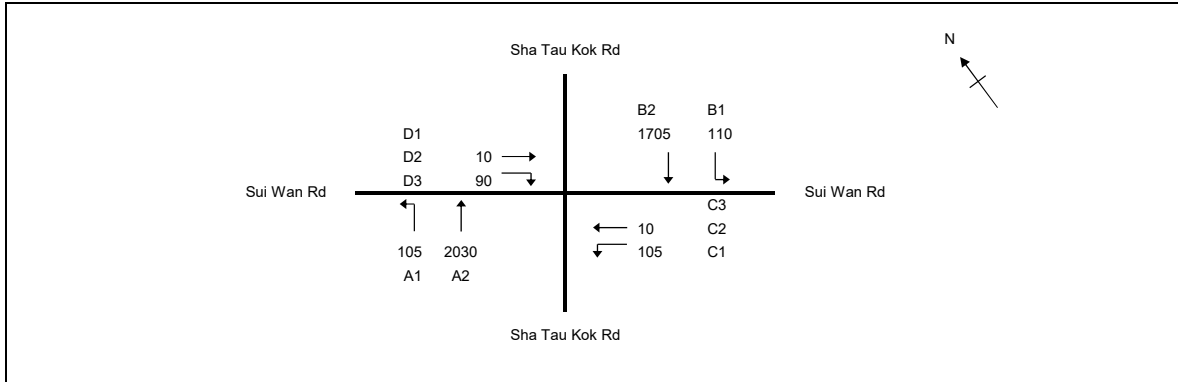

No. of stages per cycle	N = 3
No. of stage using for calculation	N = 3
Cycle time	C = 135 sec
Sum(y)	Y = 0.632
Loss time	L = 12 sec
Total Flow	= 4165 pcu
Co	= (1.5*L+5)/(1-Y) = 62.5 sec
Cm	= L/(1-Y) = 32.6 sec
Yult	= 0.810
R.C.ult	= (Yult-Y)*Y*100% = 28.1 %
Cp	= 0.9*L/(0.9-Y) = 40.3 sec
Ymax	= 1-L/C = 0.911
R.C.(C)	= (0.9*Ymax-Y)*Y*100% = 29 %

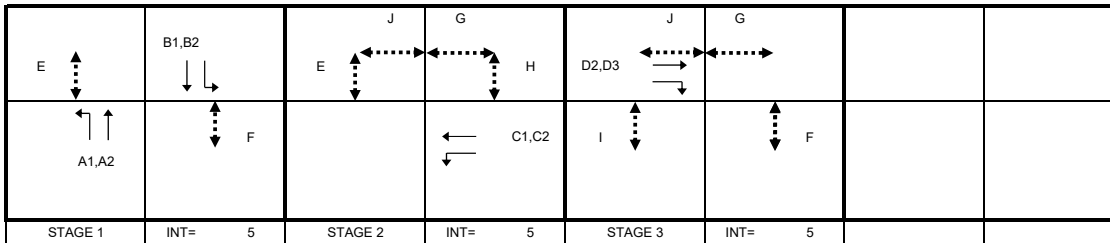

Pedestrian Phase	Width (m)	Green Time Required (s)			Green Time Provided (s)			Check
		SG	Delay	FG	SG	Delay	FG	
E	5	6	2	6	112	2	6	OK
F	5	6	2	6	110	2	6	OK
G	10.5	6	5	12	15	5	12	OK
H	5	6	2	6	9	2	6	OK
I	5	6	2	6	7	2	6	OK
J	8	6	5	9	18	5	9	OK

Move-ment	Stage	Lane Width m.	Phase	No. of lane	Radius m.	O	N	Straight-Ahead Sat. Flow	Flow			Total Flow pcu/h	Proportion of Turning Vehicles	Sat. Flow pcu/h	Uphill Gradient %	Short lane Effect pcu/h	Revised Sat. Flow pcu/h	y	Greater y	L sec	g (required) sec	g (input) sec	Degree of Saturation X	Queuing Length m.
									Left pcu/h	Straight pcu/h	Right pcu/h													
B1,B2	1	3.50	B	1	10		N	1965	110	456		566	0.19	1909		1909	0.296	0.511	12	58	99	0.403	34	
B2	1	3.50	B	2				4210		1249		1249	0.00	4210		4210	0.297			58	99	0.403	37	
A1,A2	1	3.50	A	1	10			2105	105	955		1060	0.10	2074		2074	0.511			99	99	0.694	63	
A2	1	3.50	A	1				2105		1075		1075	0.00	2105		2105	0.511			99	99	0.693	64	
C1,C2,C3	2	4.00	C	1	10		N	2015	105	10	0	115	0.91	1772		1772	0.065	0.065		13	13	0.694	23	
D1,D2,D3	3	4.00	D	1	10		N	2015	0	10	90	100	0.90	1775		1775	0.056	0.056		11	11	0.694	21	

NOTE : 'O' - OPPOSING TRAFFIC

N - NEAR SIDE LANE

SG - STEADY GREEN

FG - FLASHING GREEN

PEDESTRIAN WALKING SPEED FOR SG(FG) = 1.2(0.9)m/s

QUEUING LENGTH = AVERAGE QUEUE * 6m

J13 - Po Shek Wu Road / Po Wan Road

J13_2031_DES_AM_IMP

PROJECT NO:

Junction No. J13

DATE : 16/12/2024

FILENAME :

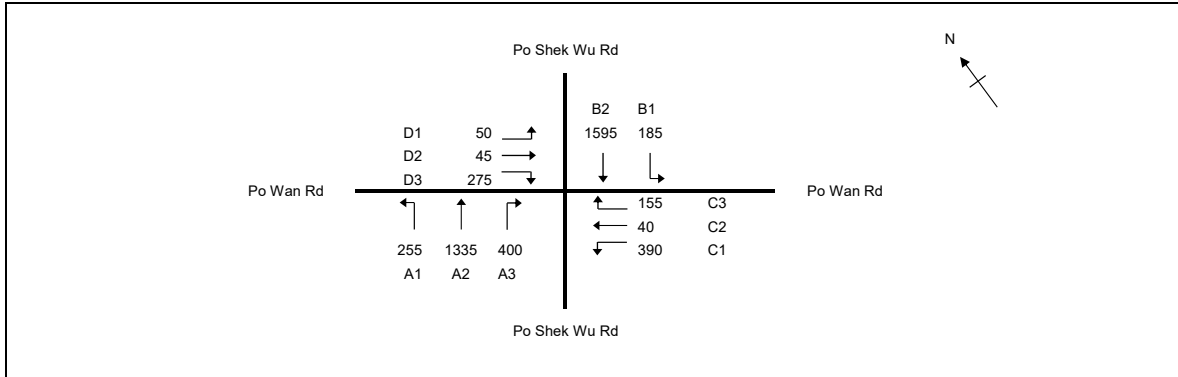

No. of stages per cycle	N = 4
No. of stage using for calculation	N = 2
Cycle time	C = 128 sec
Sum(y)	Y = 0.362
Loss time	L = 62 sec
Total Flow	= 4725 pcu
Co = (1.5*L+5)/(1-Y)	= 153.7 sec
Cm = L/(1-Y)	= 97.2 sec
Yult	= 0.435
R.C.ult = (Yult-Y)/Y*100%	= 20.0 %
Cp = 0.9*L/(0.9-Y)	= 103.8 sec
Ymax = 1-L/C	= 0.516
R.C.(C) = (0.9*Ymax-Y)/Y*100%	= 28 %

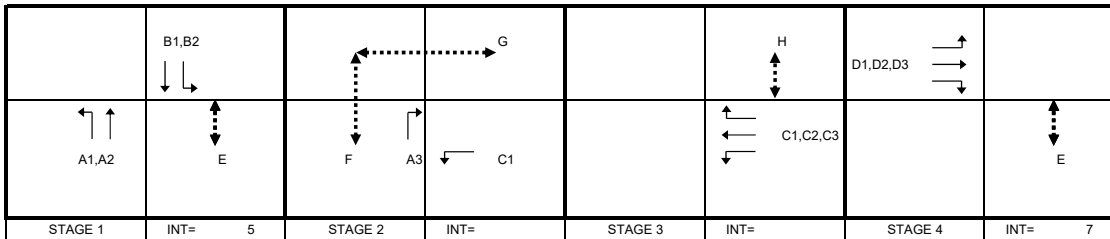

Pedestrian Phase	Width (m)	Green Time Required (s)			Green Time Provided (s)			Check
		SG	Delay	FG	SG	Delay	FG	
E	8	6	2	9	65	2	9	OK
F	8	7	6	7	15	6	7	OK
G	12	10	6	12	10	6	12	OK
H	7	6	10	8	6	10	8	OK

Movement	Stage	Lane Width m.	Phase	No. of lane	Radius m.	O	N	Straight-Ahead Sat. Flow	Flow			Total Flow pcu/h	Proportion of Turning Vehicles	Sat. Flow pcu/h	Uphill Gradient %	Short lane Effect pcu/h	Revised Sat. Flow pcu/h	y	Greater y	L sec	g (required) sec	g (input) sec	Degree of Saturation X	Queuing Length m.
									Left pcu/h	Straight pcu/h	Right pcu/h													
A1, A2	1	3.30	A	1	15		N	1945	255	233	488	0.52	1848			1848	0.264	0.264	10	48	48	0.702	65	
A2	1	3.30	A	2				4170		1102	1102	0.00	4170			4170	0.264			48	48	0.703	73	
B1	1	3.30	A	1	15			2085	185		185	1.00	1895			1895	0.098			18	48	0.260	25	
B2	1	3.30	A	3				6255		1595	1595	0.00	6255			6255	0.255			46	48	0.678	71	
A3	2	3.30	B	2	20			4170		400	400	1.00	3879			3879	0.103			19	23	0.574	35	
C1	2,3	3.30	C,D	1	15		N	1945	390		390	1.00	1768			1768	0.221			40	44	0.642	55	
C2, C3	3	3.30	D	1	20			2085	40	155	195	0.79	1968			1968	0.099			18	18	0.705	36	
D1, D2, D3	4	3.30	E	1	15		N	1945	50	45	177	0.75	1810			1810	0.098	0.098		18	18	0.700	32	
D3	4	3.30	E	1	25			2085		193	193	1.00	1967			1967	0.098			18	18	0.703	35	
PED	2		G																28					
PED	3		H																24					

NOTE : 'O' - OPPOSING TRAFFIC N - NEAR SIDE LANE SG - STEADY GREEN FG - FLASHING GREEN PEDESTRIAN WALKING SPEED FOR SG(FG) = 1.2(0.9)m/s QUEUING LENGTH = AVERAGE QUEUE * 6m

J13 - Po Shek Wu Road / Po Wan Road

J13_2031_DES_PM_IMP

PROJECT NO:

Junction No. J13

DATE : 16/12/2024

FILENAME :

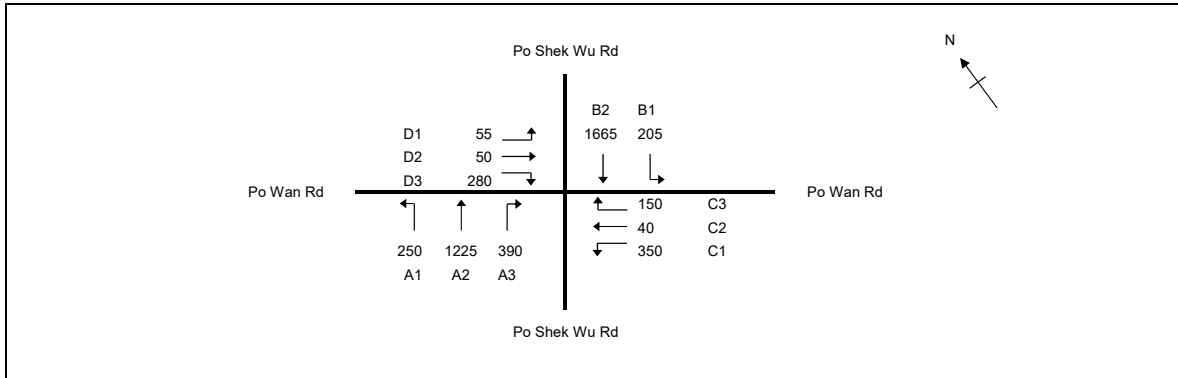

No. of stages per cycle	N = 4
No. of stage using for calculation	N = 2
Cycle time	C = 128 sec
Sum(y)	Y = 0.368
Loss time	L = 62 sec
Total Flow	= 4660 pcu
Co = (1.5*L+5)/(1-Y)	= 155.1 sec
Cm = L/(1-Y)	= 98.1 sec
Yult	= 0.435
R.C.ult = (Yult-Y)/Y*100%	= 18.1 %
Cp = 0.9*L/(0.9-Y)	= 104.9 sec
Ymax = 1-L/C	= 0.516
R.C.(C) = (0.9*Ymax-Y)/Y*100%	= 26 %

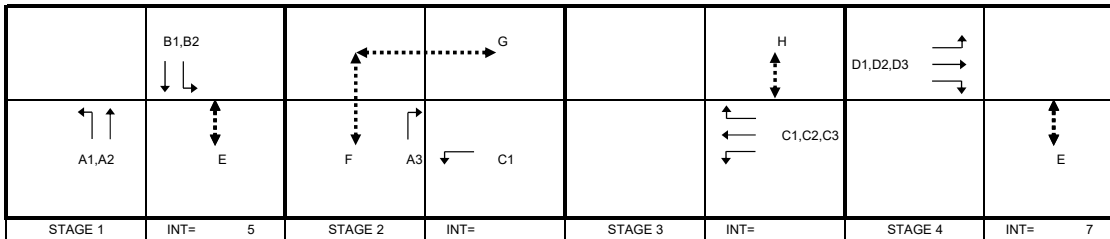

Pedestrian Phase	Width (m)	Green Time Required (s)			Green Time Provided (s)			Check
		SG	Delay	FG	SG	Delay	FG	
E	8	6	2	9	65	2	9	OK
F	8	7	6	7	15	6	7	OK
G	12	10	6	12	10	6	12	OK
H	7	6	10	8	6	10	8	OK

Movement	Stage	Lane Width m.	Phase	No. of lane	Radius m.	O	N	Straight-Ahead Sat. Flow	Flow			Total Flow pcu/h	Proportion of Turning Vehicles	Sat. Flow pcu/h	Uphill Gradient %	Short lane Effect pcu/h	Revised Sat. Flow pcu/h	y	Greater y	L sec	g (required) sec	g (input) sec	Degree of Saturation X	Queuing Length m.
									Left pcu/h	Straight pcu/h	Right pcu/h													
A1,A2	1	3.30	A	1	15		N	1945	250	202		452	0.55	1843		1843	0.245	0.266	10	44	48	0.658	60	
A2	1	3.30	A	2				4170		1023		1023	0.00	4170		4170	0.245			44	48	0.658	68	
B1	1	3.30	A	1	15			2085	205			205	1.00	1895		1895	0.108			19	48	0.290	27	
B2	1	3.30	A	3				6255		1665		1665	0.00	6255		6255	0.266			48	48	0.714	74	
A3	2	3.30	B	2	20			4170			390	390	1.00	3879		3879	0.101			18	23	0.560	34	
C1	2,3	3.30	C,D	1	15		N	1945	350			350	1.00	1768		1768	0.198			35	44	0.576	49	
C2,C3	3	3.30	D	1	20			2085		40	150	190	0.79	1968		1968	0.097			17	18	0.686	35	
D1,D2,D3	4	3.30	E	1	15		N	1945	55	50	80	185	0.73	1813		1813	0.102	0.102		18	18	0.714	34	
D3	4	3.30	E	1	25			2085			200	200	1.00	1967		1967	0.102			18	18	0.712	37	
PED	2		G																28					
PED	3		H																24					

NOTE : 'O' - OPPOSING TRAFFIC N - NEAR SIDE LANE SG - STEADY GREEN FG - FLASHING GREEN PEDESTRIAN WALKING SPEED FOR SG(FG) = 1.2(0.9)m/s QUEUING LENGTH = AVERAGE QUEUE * 6m

J16 - Sha Tau Kok Road / Fanling Bypass

J16_2031_DES_AM_WITHJ8IMP

DATE 16/12/2024

PROJECT NO. 287082

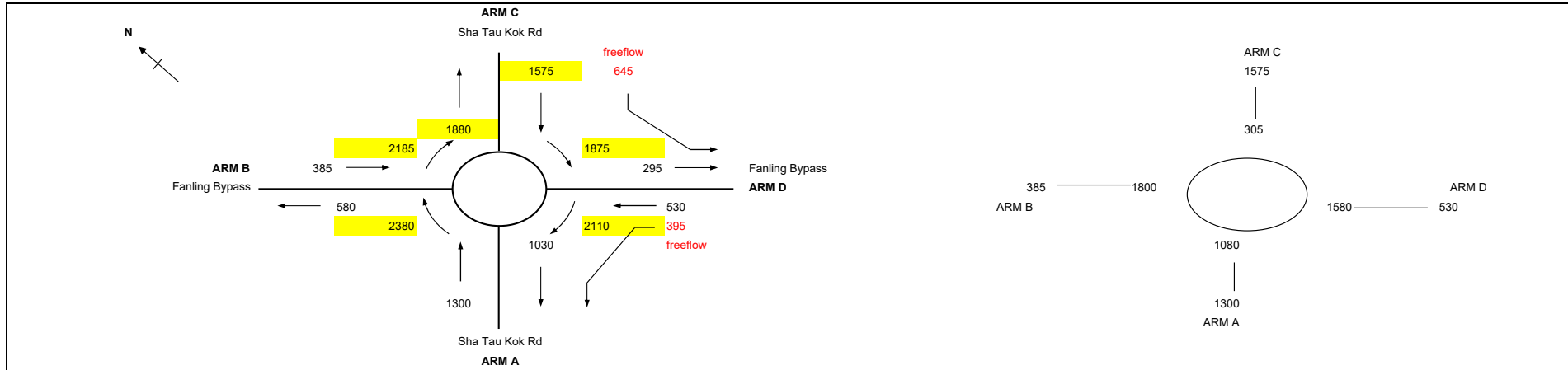

ARM	A	B	C	D
INPUT PARAMETERS:				
V = Approach half width (m)	7.30	4.50	7.30	4.50
E = Entry width (m)	10.00	7.00	10.00	7.00
L = Effective length of flare (m)	30	10	15	25
R = Entry radius (m)	50	20	20	10
D = Inscribed circle diameter (m)	75	75	75	75
A = Entry angle (degree)	10	25	20	25
Q = Entry flow (pcu/h)	1300	385	1575	530
Qc = Circulating flow across entry (pcu/h)	1080	1800	305	1580
OUTPUT PARAMETERS:				
S = Sharpness of flare = 1.6(E-V)/L	0.14	0.40	0.29	0.16
K = 1-0.00347(A-30)-0.978(1/R-0.05)	1.10	1.02	1.03	0.97
X2 = V + ((E-V)/(1+2S))	9.40	5.89	9.01	6.39
M = EXP((D-60)/10)	4.48	4.48	4.48	4.48
F = 303*X2	2847	1784	2731	1937
Td = 1+(0.5/(1+M))	1.09	1.09	1.09	1.09
Fc = 0.21*Td(1+0.2*X2)	0.66	0.50	0.64	0.52
Qe = K(F-Fc*Qc)	2345	901	2623	1077
DFC = Design flow/Capacity = Q/Qe	0.56	0.43	0.61	0.50
Total In Sum = 3790 PCU				
DFC of Critical Approach = 0.61				

J16 - Sha Tau Kok Road / Fanling Bypass

J16_2031_DES_PM_WITHJ8IMP

DATE 16/12/2024

PROJECT NO. 287082

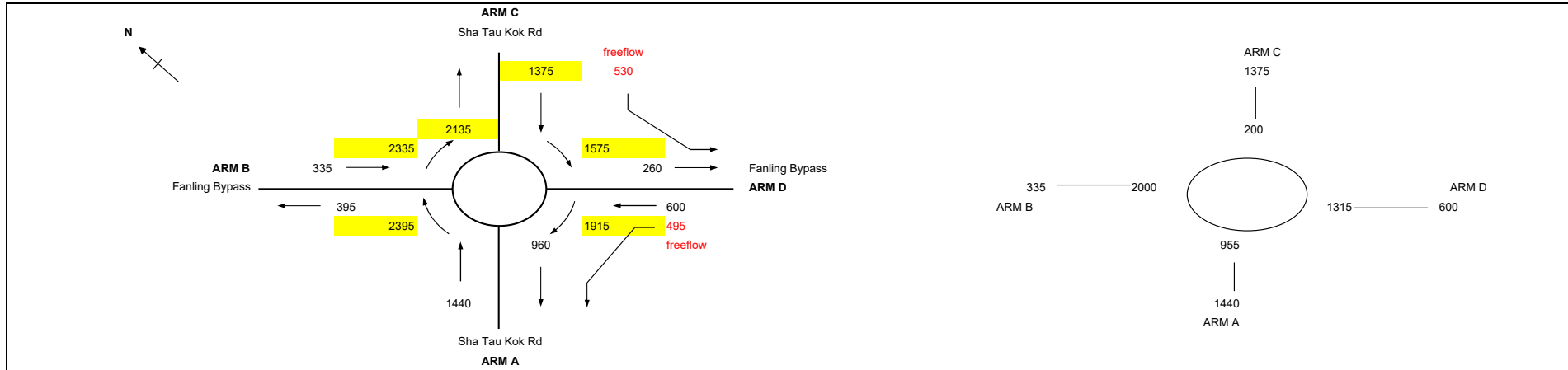

ARM	A	B	C	D
INPUT PARAMETERS:				
V = Approach half width (m)	7.30	4.50	7.30	4.50
E = Entry width (m)	10.00	7.00	10.00	7.00
L = Effective length of flare (m)	30	10	15	25
R = Entry radius (m)	50	20	20	10
D = Inscribed circle diameter (m)	75	75	75	75
A = Entry angle (degree)	10	25	20	25
Q = Entry flow (pcu/h)	1440	335	1375	600
Qc = Circulating flow across entry (pcu/h)	955	2000	200	1315
OUTPUT PARAMETERS:				
S = Sharpness of flare = 1.6(E-V)/L	0.14	0.40	0.29	0.16
K = 1-0.00347(A-30)-0.978(1/R-0.05)	1.10	1.02	1.03	0.97
X2 = V + ((E-V)/(1+2S))	9.40	5.89	9.01	6.39
M = EXP((D-60)/10)	4.48	4.48	4.48	4.48
F = 303*X2	2847	1784	2731	1937
Td = 1+(0.5/(1+M))	1.09	1.09	1.09	1.09
Fc = 0.21*Td(1+0.2*X2)	0.66	0.50	0.64	0.52
Qe = K(F-Fc*Qc)	2436	800	2693	1211
DFC = Design flow/Capacity = Q/Qe	0.60	0.42	0.52	0.50
Total In Sum = 3750 PCU				
DFC of Critical Approach = 0.60				

J23 - San Wan Road / Fanling Station Road

J23_2031_DES_AM_IMP

PROJECT NO: 287082

Junction No. J23

DATE : 16/12/2024

FILENAME :

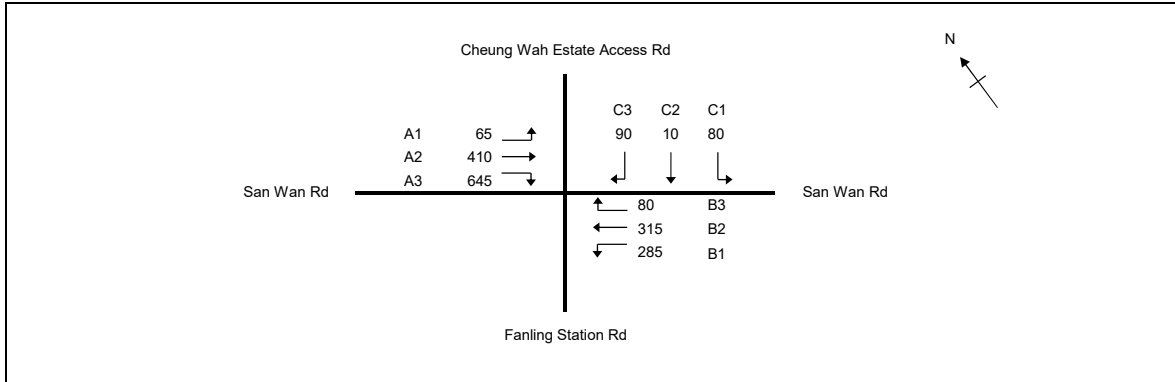

No. of stages per cycle	N =	4
No. of stage using for calculation	N =	3
Cycle time	C =	120 sec
Sum(y)	Y =	0.462
Loss time	L =	43 sec
Total Flow	=	1980 pcu
Co	= (1.5*L+5)/(1-Y)	= 129.3 sec
Cm	= L/(1-Y)	= 80.0 sec
Yult	=	0.578
R.C.ult	= (Yult-Y)/Y*100%	= 24.9 %
Cp	= 0.9*L/(0.9-Y)	= 88.4 sec
Ymax	= 1-L/C	= 0.642
R.C.(C)	= (0.9*Ymax-Y)/Y*100%	= 24 %

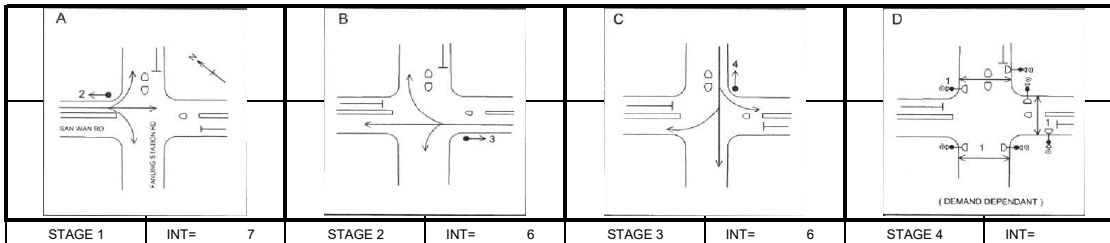

Pedestrian Phase	Width (m)	Green Time Required (s)			Green Time Provided (s)			Check
		SG	Delay	FG	SG	Delay	FG	
1	13.5	6	6	15	6	6	15	OK

Movement	Stage	Lane Width m.	Phase	No. of lane	Radius m.	O	N	Straight-Ahead Sat. Flow	Flow			Total Flow pcu/h	Proportion of Turning Vehicles	Sat. Flow pcu/h	Uphill Gradient %	Short lane Effect pcu/h	Revised Sat. Flow pcu/h	y	Greater y	L sec	g (required) sec	g (input) sec	Degree of Saturation X	Queuing Length m.
									Left pcu/h	Straight pcu/h	Right pcu/h													
A1,A2	1	3.30	2	1	10		N	1945	65	307		372	0.17	1895		1895	0.196	0.197	16	33	33	0.719	54	
A2,A3	1	3.30	2	1	15		N	2085		103	279	382	0.73	1943		1943	0.197			33	33	0.721	56	
A3	1	3.30	2	1	12.5		N	2085			366	366	1.00	1862		1862	0.197			33	33	0.721	53	
B1,B2	2	3.60	3	1	17.5		N	1975	285	35		320	0.89	1835		1835	0.174	0.175		29	29	0.719	48	
B2,B3	2	3.60	3	1	12.5		N	2115		280	80	360	0.22	2060		2060	0.175			29	29	0.721	55	
C1,C2,C3	5	5.50	4	1	15		N	2165	80	10	90	180	0.94	1978		1978	0.091	0.091		15	15	0.721	31	
PED	4		1																27					

NOTE : 'O' - OPPOSING TRAFFIC

N - NEAR SIDE LANE

SG - STEADY GREEN

FG - FLASHING GREEN

PEDESTRIAN WALKING SPEED FOR SG(FG) = 1.2(0.9)m/s

QUEUING LENGTH = AVERAGE QUEUE * 6m

J23 - San Wan Road / Fanling Station Road

J23_2031_DES_PM_IMP

PROJECT NO: 287082

Junction No. J23

DATE : 16/12/2024

FILENAME :

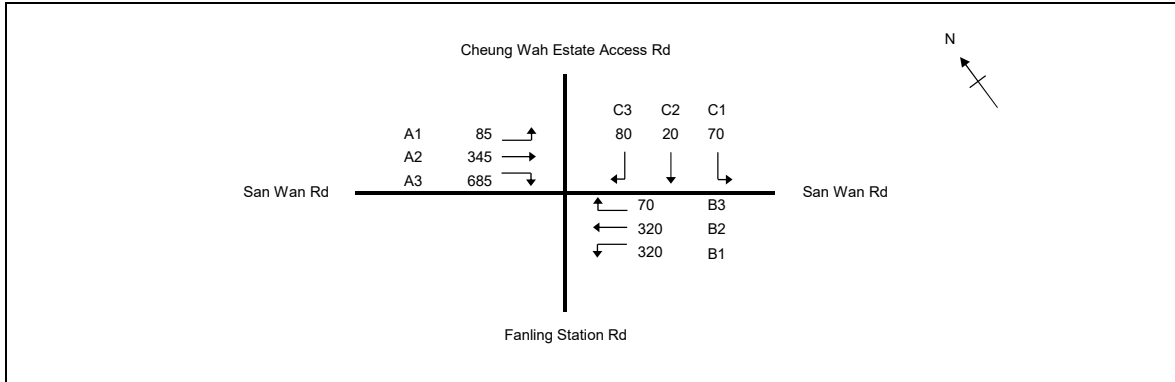

No. of stages per cycle	N = 4
No. of stage using for calculation	N = 3
Cycle time	C = 120 sec
Sum(y)	Y = 0.465
Loss time	L = 43 sec
Total Flow	= 1995 pcu
Co	= (1.5*L+5)/(1-Y) = 129.9 sec
Cm	= L/(1-Y) = 80.4 sec
Yult	= 0.578
R.C.ult	= (Yult-Y)/Y*100% = 24.2 %
Cp	= 0.9*L/(0.9-Y) = 89.0 sec
Ymax	= 1-L/C = 0.642
R.C.(C)	= (0.9*Ymax-Y)/Y*100% = 24 %

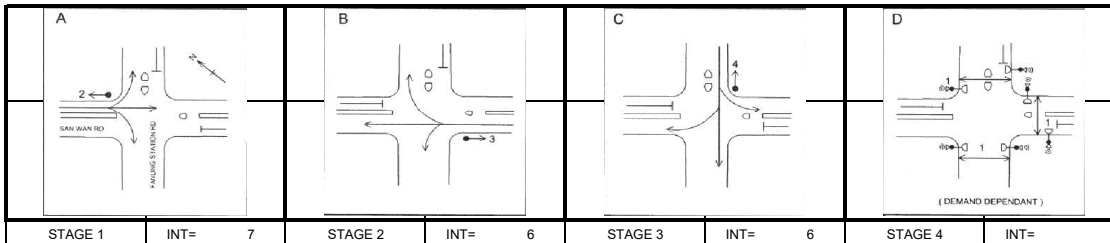

Pedestrian Phase	Width (m)	Green Time Required (s)			Green Time Provided (s)			Check
		SG	Delay	FG	SG	Delay	FG	
1	13.5	6	6	15	6	6	15	OK

Move-ment	Stage	Lane Width m.	Phase	No. of lane	Radius m.	O	N	Straight-Ahead Sat. Flow	Flow			Total Flow pcu/h	Proportion of Turning Vehicles	Sat. Flow pcu/h	Uphill Gradient %	Short lane Effect pcu/h	Revised Sat. Flow pcu/h	y	Greater y	L sec	g (required) sec	g (input) sec	Degree of Saturation X	Queuing Length m.
									Left pcu/h	Straight pcu/h	Right pcu/h													
A1,A2	1	3.30	2	1	10		N	1945	85	285		370	0.23	1880		1880	0.197	0.197	16	33	33	0.724	54	
A2,A3	1	3.30	2	1	15		N	2085		60	319	379	0.84	1923		1923	0.197			33	33	0.725	55	
A3	1	3.30	2	1	12.5		N	2085			366	366	1.00	1862		1862	0.197			33	33	0.723	53	
B1,B2	2	3.60	3	1	17.5		N	1975	320	13		333	0.96	1825		1825	0.182	0.182		30	30	0.725	50	
B2,B3	2	3.60	3	1	12.5		N	2115		307	70	377	0.19	2069		2069	0.182			30	30	0.724	56	
C1,C2,C3	5	5.50	4	1	15		N	2165	70	20	80	170	0.88	1989		1989	0.085	0.085		14	14	0.725	30	
PED	4		1																27					

NOTE : 'O' - OPPOSING TRAFFIC

N - NEAR SIDE LANE

SG - STEADY GREEN

FG - FLASHING GREEN

PEDESTRIAN WALKING SPEED FOR SG(FG) = 1.2(0.9)m/s

QUEUING LENGTH = AVERAGE QUEUE * 6m